

DATA SHEET

SKY13592-689LF: 1.0 to 6.0 GHz SPDT Switch

Applications

- WLAN 802.11 a/b/g/n/ac networks
- WLAN repeaters
- ISM band radios
- Low power transmit receive systems
- Smartphones
- Connectivity modules

Features

- Broadband frequency range: 1.0 to 6.0 GHz
- Low insertion loss, 0.45 dB typical @ 2.45 GHz
- High isolation, 35 dB typical @ 2.45 GHz
- Excellent linearity performance, $IP0.1dB = +30$ dBm
- Integrated DC blocking capacitors
- Ultra-miniature, MLPD (6-pin, $1 \times 1 \times 0.5$ mm) package (MSL1, 260 °C per JEDEC J-STD-020)



Skyworks Green™ products are compliant with all applicable legislation and are halogen-free. For additional information, refer to *Skyworks Definition of Green™*, document number SQ04-0074.

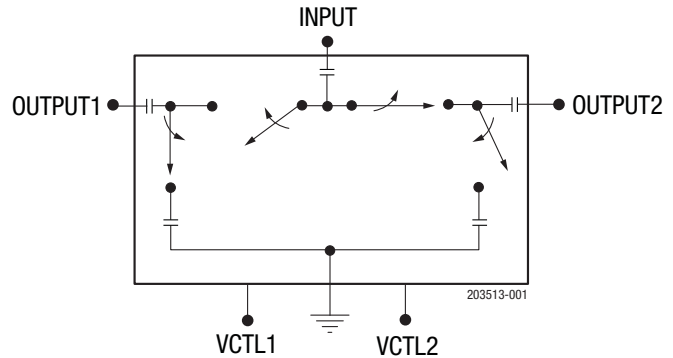

Figure 1. SKY13592-689LF Block Diagram

Description

The SKY13592-689LF is a single-pole, double-throw (SPDT) switch intended for mode switching in WLAN applications. Using advanced switching technologies, the SKY13592-689LF maintains low insertion loss and high isolation for all switching paths.

The high-linearity performance and low insertion loss achieved by the switch make it an ideal choice for low-power transmit/receive applications. Depending on the logic voltage applied to the control pins (VCTL), the INPUT pin is connected to one of the two switched RF outputs (OUTPUT1 or OUTPUT2) using a low insertion loss path, while the path between the INPUT pin and the other OUTPUT pin is in a high-isolation state. The switch is "reflective short" on the isolated port.

The SKY13592-689LF has integrated DC blocking capacitors, so no external DC blocking capacitors are required.

The switch is manufactured in a compact, $1 \times 1 \times 0.5$ mm, 6-pin exposed pad plastic Micro Lead-frame Package Dual (MLPD) package.

A functional block diagram is shown in Figure 1. The pin configuration and package are shown in Figure 2. Signal pin assignments and functional pin descriptions are provided in Table 1.

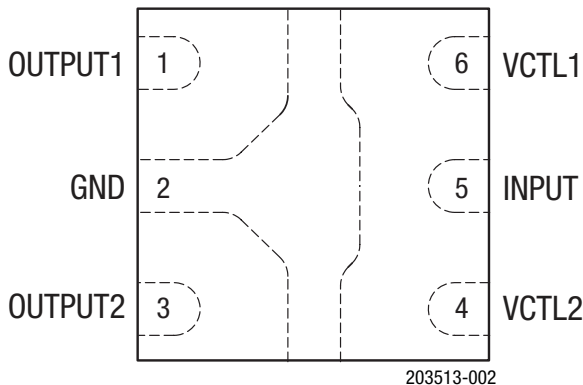

Figure 2. SKY13592-689LF Pinout (Top View)

Table 1. SKY13592-689LF Signal Descriptions

Pin	Name	Description	Pin	Name	Description
1	OUTPUT1	RF port.	4	VCTL2	DC control voltage 2
2	GND	Ground	5	INPUT	RF port.
3	OUTPUT2	RF port.	6	VCTL1	DC control voltage 1

Electrical and Mechanical Specifications

The absolute maximum ratings of the SKY13592-689LF are provided in Table 2. The recommended operating conditions are specified in Table 3, and electrical specifications are provided in Table 4.

The state of the SKY13592-689LF is determined by the logic provided in Table 5. Typical performance characteristics are shown in Figures 3 through 6.

Table 2. SKY13592-689LF Absolute Maximum Ratings¹

Parameter	Symbol	Minimum	Maximum	Units
Input power	PIN		+32	dBm
Control voltage	VCTL		3.7	V
Storage temperature	TSTG	-65	+150	°C
Operating temperature	TOP	-40	+90	°C

¹ Exposure to maximum rating conditions for extended periods may reduce device reliability. There is no damage to device with only one parameter set at the limit and all other parameters set at or below their nominal value. Exceeding any of the limits listed here may result in permanent damage to the device.

ESD HANDLING: *Although this device is designed to be as robust as possible, electrostatic discharge (ESD) can damage this device. This device must be protected at all times from ESD when handling or transporting. Static charges may easily produce potentials of several kilovolts on the human body or equipment, which can discharge without detection. Industry-standard ESD handling precautions should be used at all times.*

Table 3. SKY13592-689LF Recommended Operating Conditions

Parameter	Symbol	Min	Typ	Max	Units
Operating frequency	fo	1.0		6.0	GHz
Control voltage:					
Low	VCTL_L		0	0.4	V
High	VCTL_H	3.0	3.3	3.6	V
Operating temperature	TOP		+25		°C

Table 4. SKY13592-689LF Electrical Specifications¹
(VCTL = 0 V and 3.3 V, Top = +25 °C, PIN = 0 dBm, Characteristic Impedance [Zo] = 50 Ω, Unless Otherwise Noted)

Parameter	Symbol	Test Condition	Min	Typ	Max	Units
Insertion loss	IL	1.0 to 2.5 GHz		0.45	0.65	dB
		4.8 to 6.0 GHz		0.55	0.8	dB
Isolation (INPUT to OUTPUT1/OUTPUT2)	ISO	1.0 to 2.5 GHz	31	35		dB
		4.8 to 6.0 GHz	20	24		dB
Isolation (OUTPUT1 to OUTPUT2)	ISO	1.0 to 2.5 GHz	32	36		dB
		4.8 to 6.0 GHz	20	23		dB
Return loss	RL	1.0 to 2.5 GHz		15		dB
		4.8 to 6.0 GHz		15		dB
PO.1dB compression point	PO.1dB	1.0 to 6 GHz		+30		dBm
Harmonics	2fo	fo = 2.4 GHz, PIN = +24 dBm, 50 Ω, VCTL = 3.3 V		-59	-55	dBm
		fo = 5.8 GHz, PIN = +21 dBm, 50 Ω, VCTL = 3.3 V		-59		dBm
	3fo	fo = 2.4 GHz, PIN = +24 dBm, 50 Ω, VCTL = 3.3 V		-40	-36	dBm
		fo = 5.8 GHz, PIN = +21 dBm, 50 Ω, VCTL = 3.3 V		-48		dBm
Input IP3	IP3	PIN = +20 dBm/tone: fo = 2.4 GHz	+50	+55		dBm
		fo = 5.8 GHz	+46	+50		dBm
Error vector magnitude	EVM	802.11g, 54 Mbps, PIN = +25.5 dBm, 2.45 GHz		-45		dB
		802.11g, 54 Mbps, PIN = +25.5 dBm, 5.8 GHz		-38		dB
		802.11g, 54 Mbps, PIN = +21 dBm, 5.8 GHz		-46		dB
Switching speed	tsw	50% VCTL to 90% RF		450	550	ns
Rise/fall time		10%/90% or 90%/10% RF		210	250	ns
Control current	ICTL	VCTL = 3.3 V		200	250	μA

¹ Performance is guaranteed only under the conditions listed in this table.

Table 5. SKY13592-689LF Truth Table¹

VCTL1 (Pin 6)	VCTL2 (Pin 4)	INPUT to OUTPUT1 Path	INPUT to OUTPUT2 Path
1	0	Isolation	Insertion loss
0	1	Insertion loss	Isolation

¹ "1" indicates VCTL = 3.0 to 3.6 V.

"0" indicates VCTL = 0 to 0.4 V.

Any state other than described in this table places the switch into an undefined state. An undefined state will not damage the device.

Typical Performance Characteristics

(VCTL = 0 V and 3.3 V, TOP = +25 °C, PIN = 0 dBm, Characteristic Impedance [Zo] = 50 Ω, Unless Otherwise Noted)

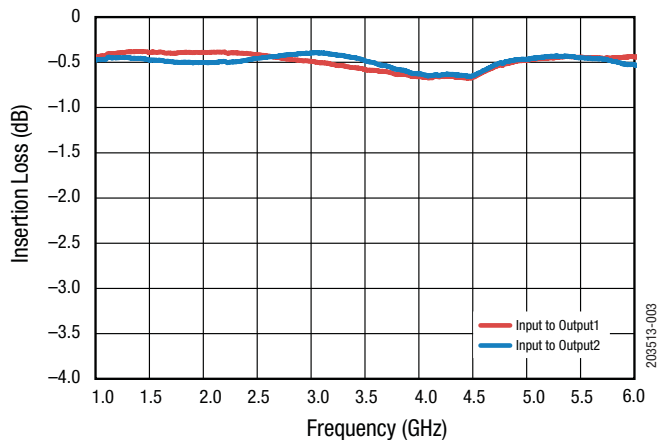

Figure 3. Typical Insertion Loss

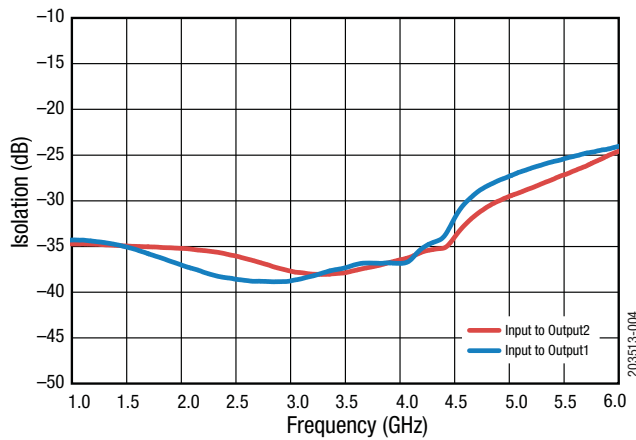

Figure 4. Typical Isolation (Input-Output)

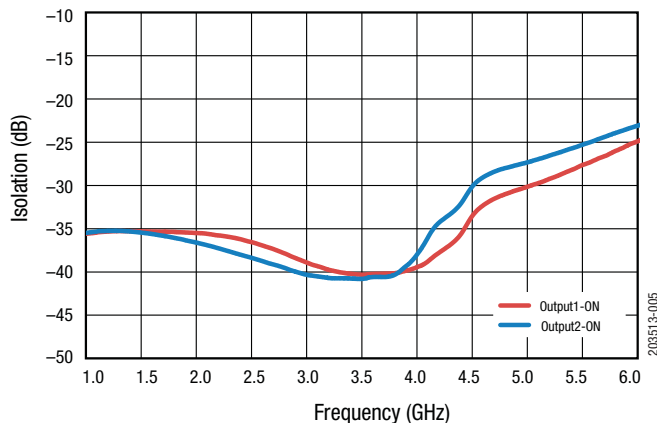

Figure 5. Typical Isolation (Output1-Output2)

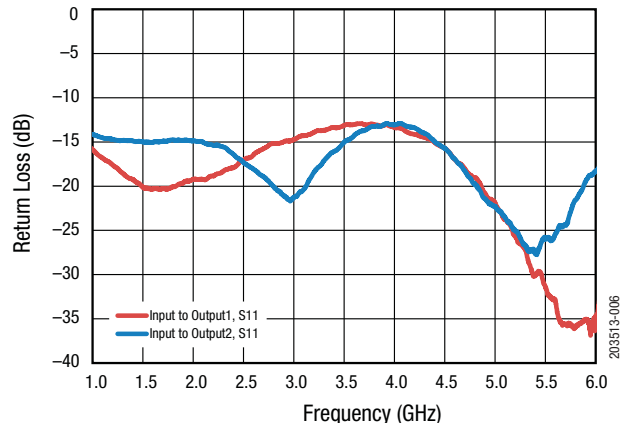

Figure 6. Typical Return Loss

Evaluation Board Description

The SKY13592-689LF Evaluation Board is used to test the performance of the SKY13592-689LF SPDT Switch. An Evaluation Board schematic diagram is provided in Figure 7. An assembly drawing for the Evaluation Board is shown in Figure 8.

Package Dimensions

The PCB layout footprint for the SKY13592-689LF is provided in Figure 9. Typical part markings are shown in Figure 10. Package dimensions are shown in Figure 11, and tape and reel dimensions are provided in Figure 12.

Package and Handling Information

Instructions on the shipping container label regarding exposure to moisture after the container seal is broken must be followed. Otherwise, problems related to moisture absorption may occur when the part is subjected to high temperature during solder assembly.

The SKY13592-689LF is rated to Moisture Sensitivity Level 1 (MSL1) at 260 °C. It can be used for lead or lead-free soldering. For additional information, refer to the Skyworks Application Note, *Solder Reflow Information*, document number 200164.

Care must be taken when attaching this product, whether it is done manually or in a production solder reflow environment. Production quantities of this product are shipped in a standard tape and reel format.

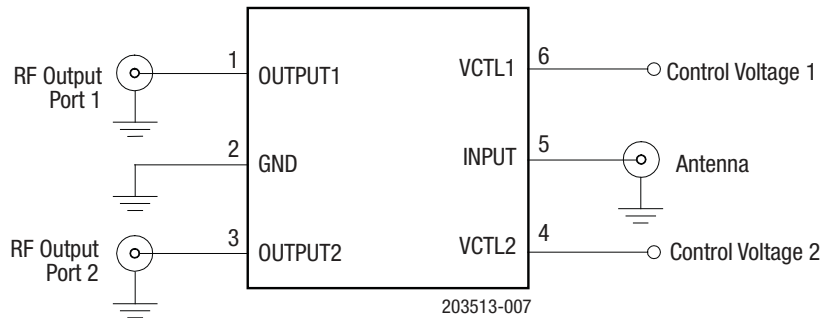

Figure 7. SKY13592-689LF Evaluation Board Schematic

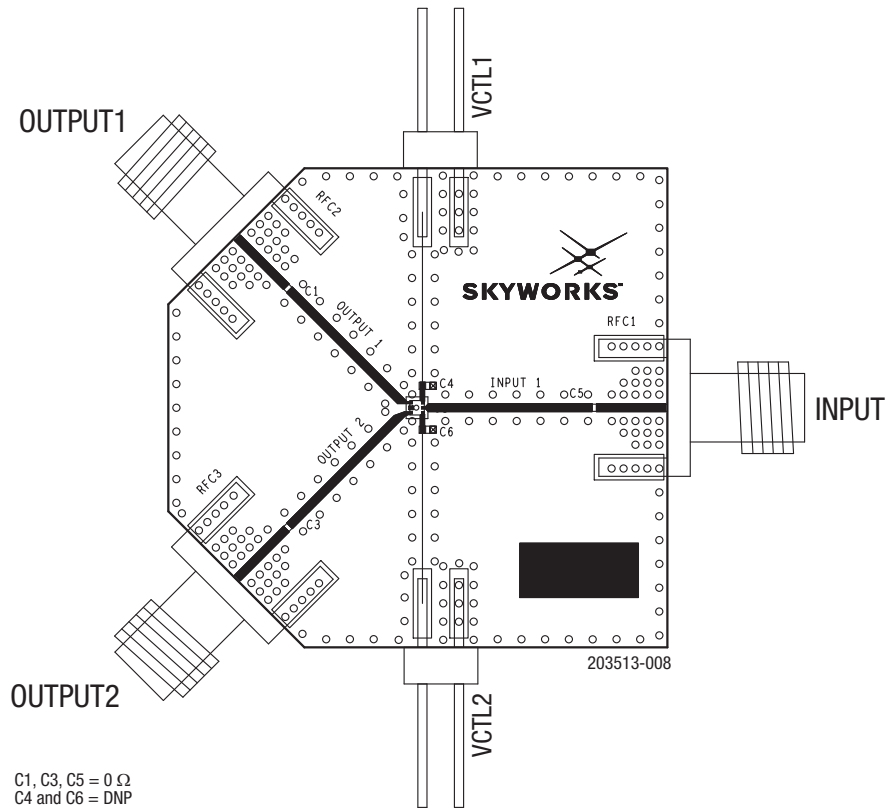
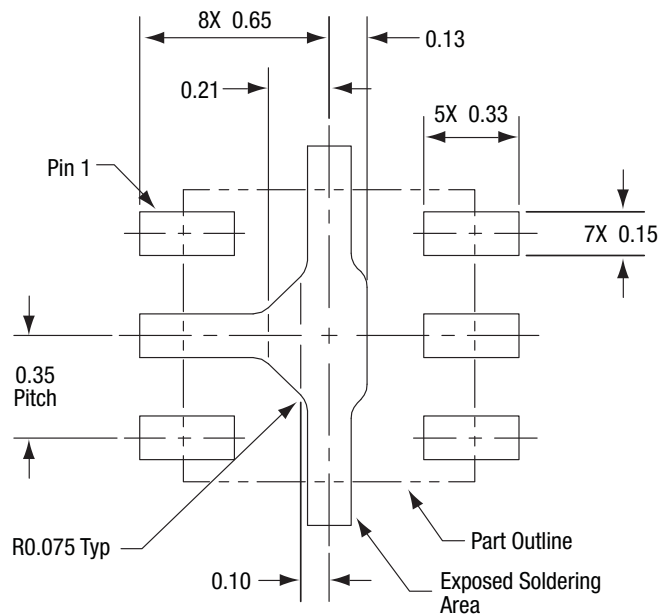

Figure 8. SKY13592-689LF Evaluation Board Assembly Diagram



All measurements in millimeters

203513-009

Figure 9. SKY13592-689LF PCB Layout Footprint (Top View)

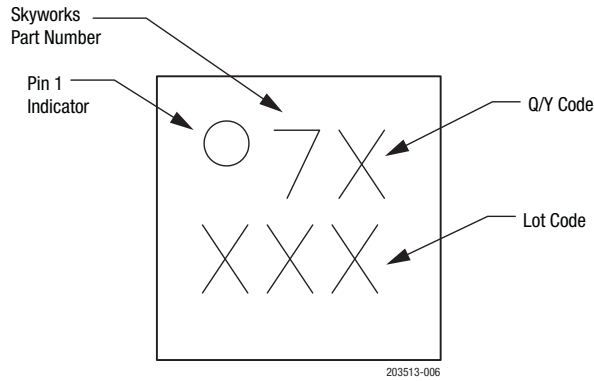

Figure 10. Typical Part Markings (Top View)

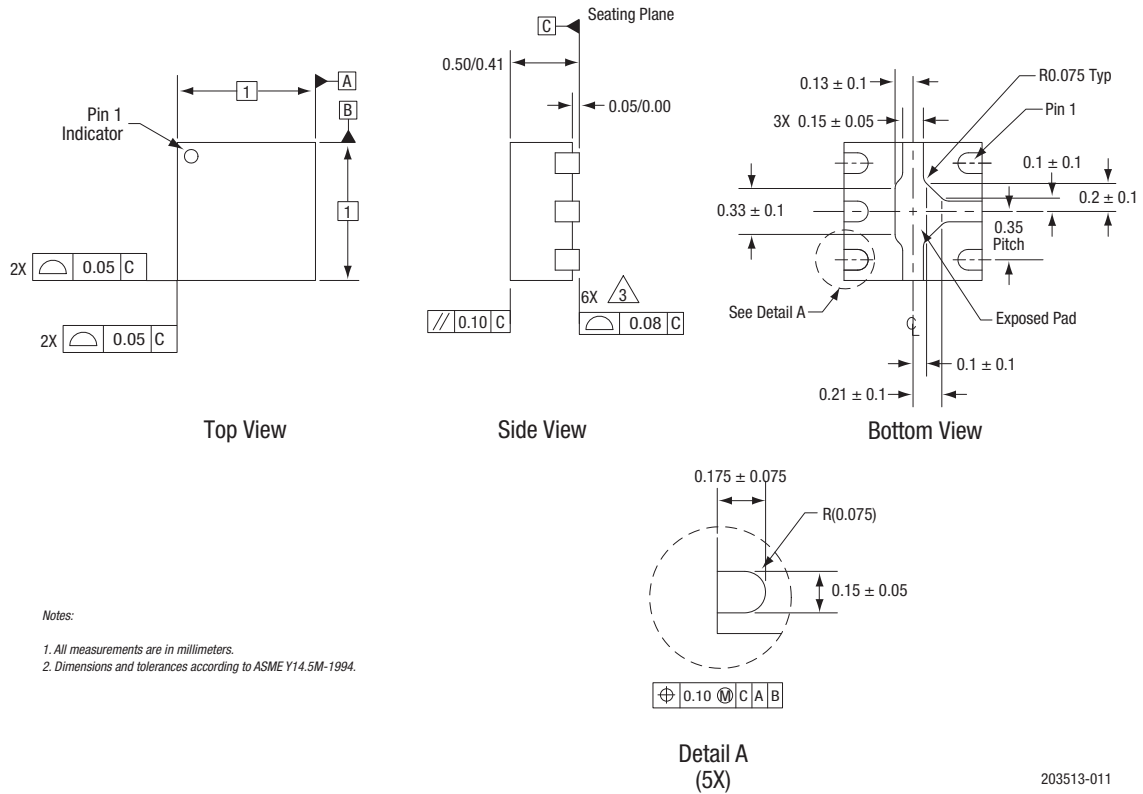
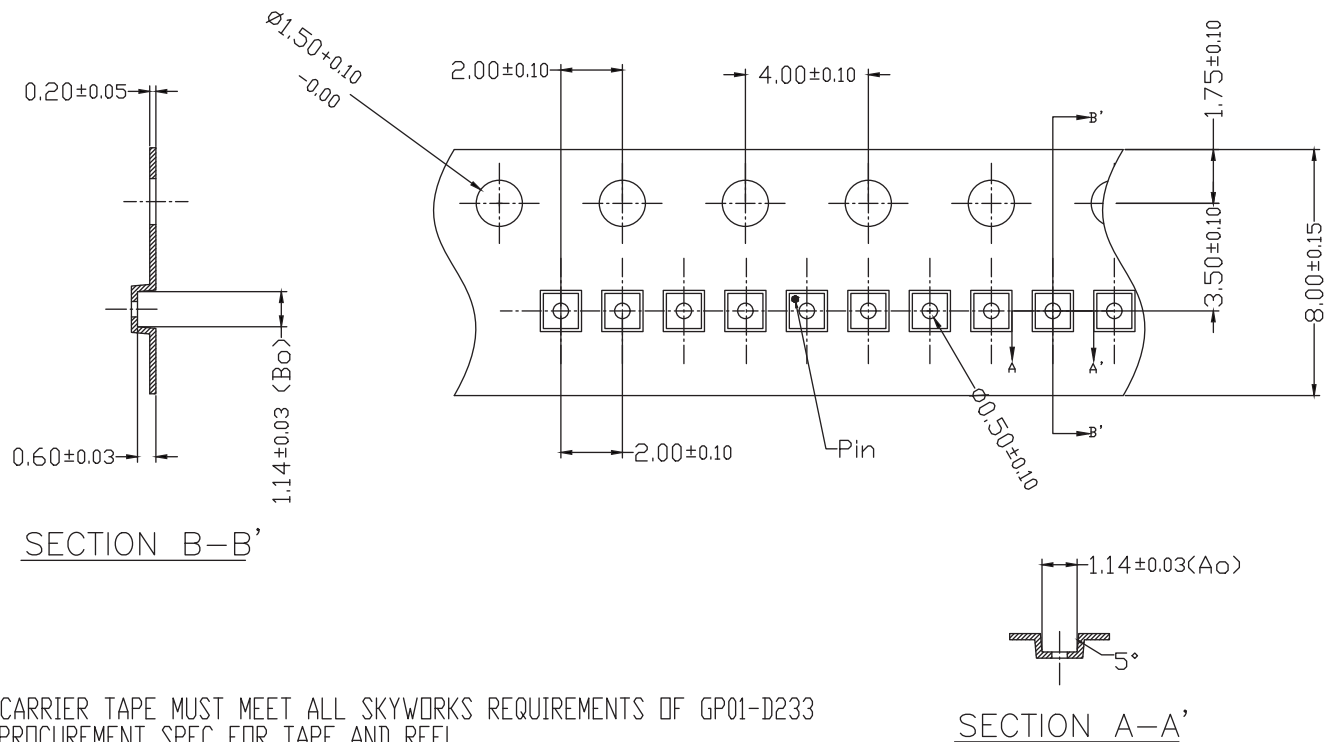

Figure 11. SKY13592-689LF Package Dimensions



1. CARRIER TAPE MUST MEET ALL SKYWORKS REQUIREMENTS OF GP01-D233 PROCUREMENT SPEC FOR TAPE AND REEL
2. CARRIER TAPE SHALL BE BLACK CONDUCTIVE POLYCARBONATE.
3. COVER TAPE SHALL BE TRANSPARENT CONDUCTIVE MATERIAL
4. ESD-SURFACE RESISTIVITY SHALL MEET GP01-D233
5. 10 SPROCKET HOLE PITCH CUMULATIVE TOLERANCE : $\pm 0.20\text{mm}$
6. A_o & B_o MEASURED ON PLANE 0.30mm ABOVE THE BOTTOM OF THE POCKET.
7. ALL DIMENSIONS ARE IN MILLIMETERS.

SECTION A-A'

204513-012

Figure 12. SKY13592-689LF Tape and Reel Dimensions