

DATA SHEET

SKY65017-70LF: 0.1 to 6.0 GHz InGaP Cascadable Amplifier

Applications

- Wireless infrastructure: WLAN, HLAN, DBS, broadband, cellular base stations
- Test instrumentation
- Cable television

Features

- Broadband frequency range: 0.1 to 6.0 GHz
- Small signal gain = 20 dB typical @ 2 GHz
- High OIP3: +33 dBm typical
- OP1dB = +20 dBm typical @ 2 GHz
- Input and output impedance: 50 Ω nominal
- Single, positive DC supply voltage
- SOT-89 (4-pin, 1.5 x 4.0 mm) package (MSL1, 260 °C per JEDEC J-STD-020)



Skyworks Green™ products are compliant with all applicable legislation and are halogen-free. For additional information, refer to *Skyworks Definition of Green™*, document number SQ04-0074.

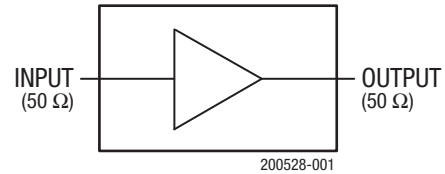

Figure 1. SKY65017-70LF Functional Block Diagram

Description

Skyworks SKY65017-70LF is a general purpose, broadband amplifier. The device is fabricated from Skyworks InGaP HBT process and packaged in a miniature Small Outline Transistor (SOT-89) package.

The device's 50 Ω input and output impedance allow it to be easily cascaded without external impedance matching networks. The typical -3 dB bandwidth of the SKY65017-70LF is 0.1 to 6.0 GHz.

A functional block diagram is provided in Figure 1. The device package and pinout are shown in Figure 2.

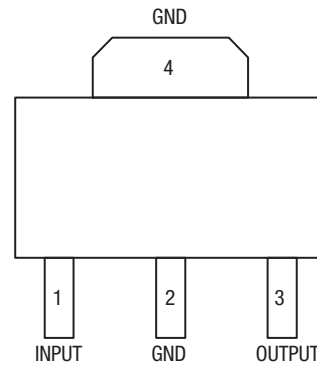

200528-002

Figure 2. SKY65017-70LF Pinout Package (Top View)

Electrical and Mechanical Specifications

Signal pin assignments and functional pin descriptions are described in Table 1. The absolute maximum ratings of the SKY65017-70LF are provided in Table 2. Electrical specifications are provided in Table 3.

Typical performance characteristics of the SKY65017-70LF are illustrated in Figures 3 through 6.

Table 1. SKY65017-70LF Signal Descriptions

Pin	Name	Description
1	INPUT	RF input with 50 Ω nominal input impedance. An internally generated DC voltage is present at this pin, so an external DC block should be used to connect this pin to the external circuit.
2	GND	Ground
3	OUTPUT	RF output. DC supply voltage input and RF output with 50 Ω nominal output impedance. The nominal voltage required at this pin is listed in Table 3. Supply current is determined by an external resistor connected between the DC power supply and this pin.
4	GND	Ground

Table 2. SKY65017-70LF Absolute Maximum Ratings¹

Parameter	Symbol	Minimum	Maximum	Units
Supply voltage	V _{CC}		6	V
RF input power	P _{IN}		+10	dBm
Supply current	I _{CC}		120	mA
Power dissipation @ T _c = 25 °C	P _D		510	mW
Operating case temperature	T _C	-40	+85	°C
Storage temperature	T _{ST}	-65	+125	°C
Junction temperature	T _J		+150	°C
Thermal resistance	Θ _{JC}		70	°C/W

¹ Exposure to maximum rating conditions for extended periods may reduce device reliability. There is no damage to device with only one parameter set at the limit and all other parameters set at or below their nominal values. Exceeding any of the limits listed here may result in permanent damage to the device.

ESD HANDLING: *Although this device is designed to be as robust as possible, electrostatic discharge (ESD) can damage this device. This device must be protected at all times from ESD when handling or transporting. Static charges may easily produce potentials of several kilovolts on the human body or equipment, which can discharge without detection. Industry-standard ESD handling precautions should be used at all times.*

Table 3. SKY65017-70LF Electrical Specifications¹

($I_{DD} = 100 \text{ mA}$, $T_c = 25 \text{ }^\circ\text{C}$, $P_{IN} = -10 \text{ dBm}$, Characteristic Impedance [Z_0] = $50 \text{ } \Omega$, Unless Otherwise Noted)

Parameter	Symbol	Test Conditions	Min	Typ	Max	Units
Small signal gain	IS21I	@ 2 GHz	19	20	22	dB
3 dB gain bandwidth ²	BW _{3dB}			6		GHz
Noise figure ²	NF	@ 2 GHz		4.5	5.0	dB
1 dB output compression point	OP1dB	@ 2 GHz	+19	+20		dBm
Input and output VSWR ²	VSWR	0.1 to 5.0 GHz		1.9:1	2.0:1	-
Third order output intercept point	OIP3	@ 2 GHz, $P_{IN} = 0 \text{ dBm/}$ tone, $\Delta f = 10 \text{ MHz}$	+32	+33		dBm
Operating voltage	V _{CC}	Measured @ P1dB	4.5	5.0	5.5	V
Reverse isolation ²	IS12I	0.1 to 6.0 GHz		23		dB
Gain flatness ²		10 MHz to 6 GHz		± 1.5		dB

¹ Performance is guaranteed only under the conditions listed in this table.

² Not tested in production. Verified by design.

Typical Performance Characteristics

($I_{DD} = 100 \text{ mA}$, Characteristic Impedance [Z_0] = $50 \text{ } \Omega$, Unless Otherwise Noted)

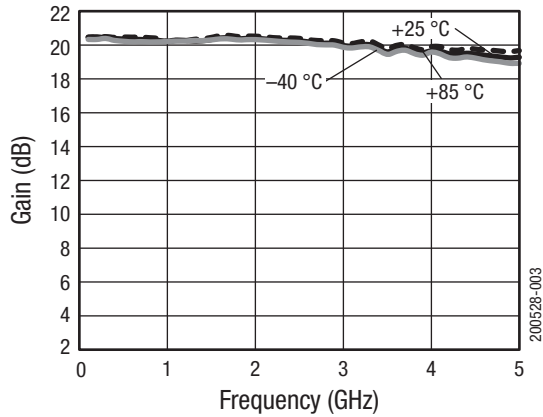

Figure 3. Small Signal Gain vs Frequency

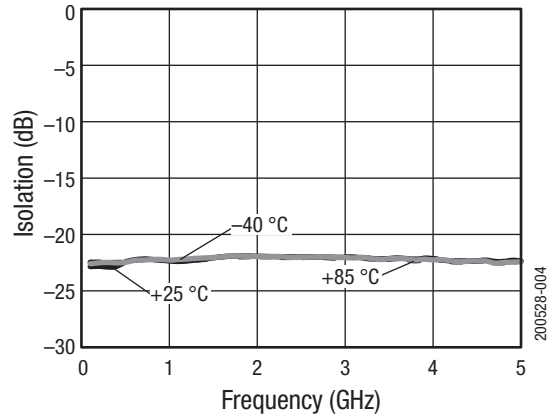

Figure 4. Isolation vs Frequency

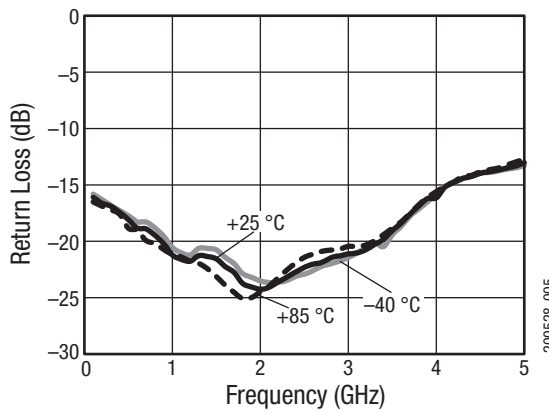

Figure 5. Input Return Loss vs Frequency

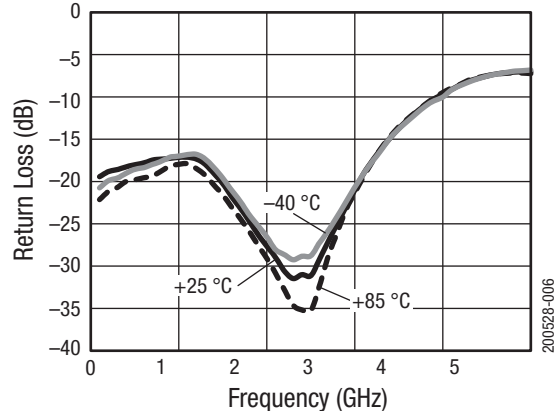

Figure 6. Output Return Loss vs Frequency

Evaluation Board Description

The Skyworks SKY65017-70LF Evaluation Board is used to test the performance of the SKY65017-70LF cascaded amplifier. The Evaluation Board is shown in Figure 7. An Evaluation Board schematic is shown in Figure 8. Table 4 provides the Bill of Materials (BOM) for Evaluation Board components.

The input and output of the SKY65017-70LF are connected using 50 Ω microstrip transmission lines with DC blocking capacitors, C1 and C2, to the input and output SMA connectors, respectively.

The positive supply voltage, V_{CC}, is connected to pin 3 (OUTPUT) of the amplifier using the decoupling network that consists of C4, L1, L2, and R1. The power supply current, I_{DD}, must be limited either by the current limit function of an external bench power supply or by replacing L3 with resistor R1, the value of which is given in shown in Table 5.

The Evaluation Board is shipped with L3 in place, which shifts an in-band series resonance of the supply decoupling network out-of-band. For low-frequency applications, R1 may be used to conveniently limit supply current on the Evaluation Board.

The Evaluation Board also contains a probe fixture that facilitates the direct measurement of the S-parameters. The probe fixture comprises a very short Co-Planar Waveguide (CPW) transmission line to pin 1 and an identical line to pin 3. The other two pins of the amplifier are grounded. The CPW transmission lines are compatible with ground-signal-ground wafer probe tips, which can be connected to the RF ports of a Vector Network Analyzer (VNA) using coaxial cables.

The very small electrical length of these CPW transmission lines obviates the need to de-embed their effects from the S-parameters that are measured. The supply constant current must be applied using the bias tee, which is typically integrated into the VNA, and cascaded with the OUTPUT pin of the amplifier.

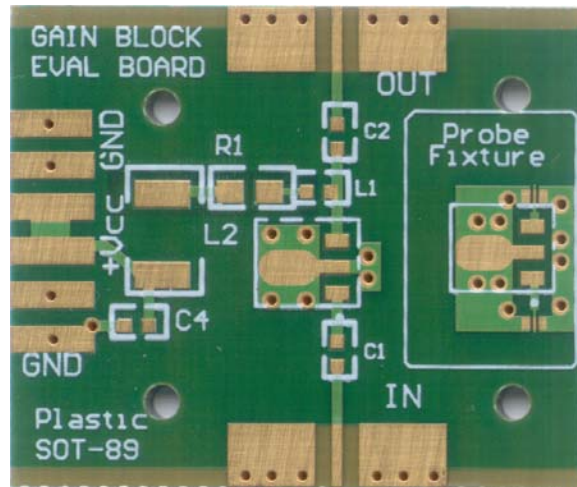

Figure 7. SKY65017-70LF Evaluation Board

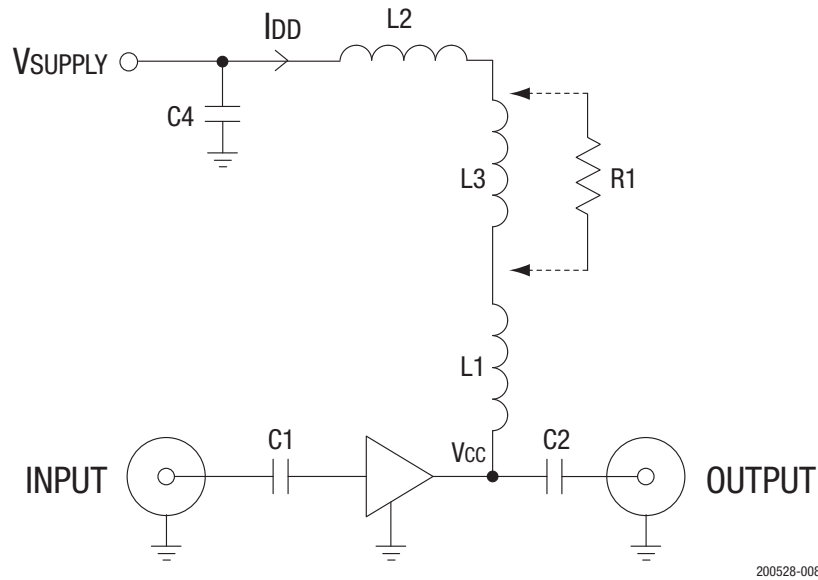

Figure 8. SKY65017-70LF Evaluation Board Schematic

Table 4. SKY65017-70LF Evaluation Board Bill of Materials (BOM)

Component	Value	Size	Part Number	Manufacturer
C1, C2, C4	47 nF	0603	GRM188R71E473K	Murata
L1	33 nH	0603	0603CS-33NX_LU	Coilcraft
L2	1600 Ω	1810	FBMH4525HM162N-T	Taiyo-Yuden
L3	110 nH	0805	0805CS-111X_L	Coilcraft
R1	See Table 5	0603	Variable	Variable

Table 5. Current Limiting Resistor Values

Supply Voltage (V)	Value of R1 (Ω)	Minimum Power Dissipation Rating (mW)
5 ¹	0	-
6	10	250
7	20	500
8	30	500
9	40	1000
10	50	1000
12	70	2000

¹ To ensure that the supply current does not exceed the recommended value, a regulated current source should be used to supply the device under this condition.

Package Dimensions

Typical part markings for the SKY65017-70LF are shown in Figure 9. The PCB layout footprint for the SKY65017-70LF is provided in Figure 10. Package dimensions are provided in Figure 11, and tape and reel dimensions are shown in Figure 12.

Package and Handling Information

Instructions on the shipping container label regarding exposure to moisture after the container seal is broken must be followed. Otherwise, problems related to moisture absorption may occur when the part is subjected to high temperature during solder assembly.

The SKY65017-70LF is rated to Moisture Sensitivity Level 1 (MSL1) at 260 °C. It can be used for lead or lead-free soldering. For additional information, refer to the Skyworks Application Note, *Solder Reflow Information*, document number 200164.

Care must be taken when attaching this product, whether it is done manually or in a production solder reflow environment. Production quantities of this product are shipped in a standard tape and reel format.

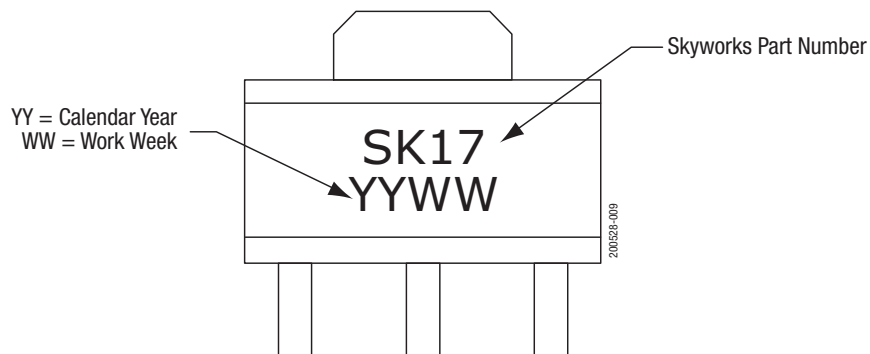

Figure 9. SKY65017-70LF Typical Part Markings

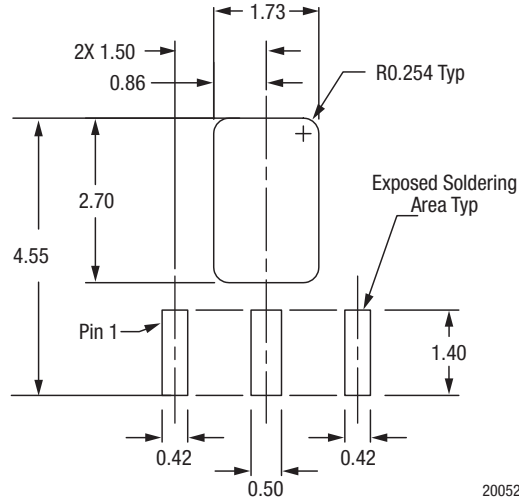
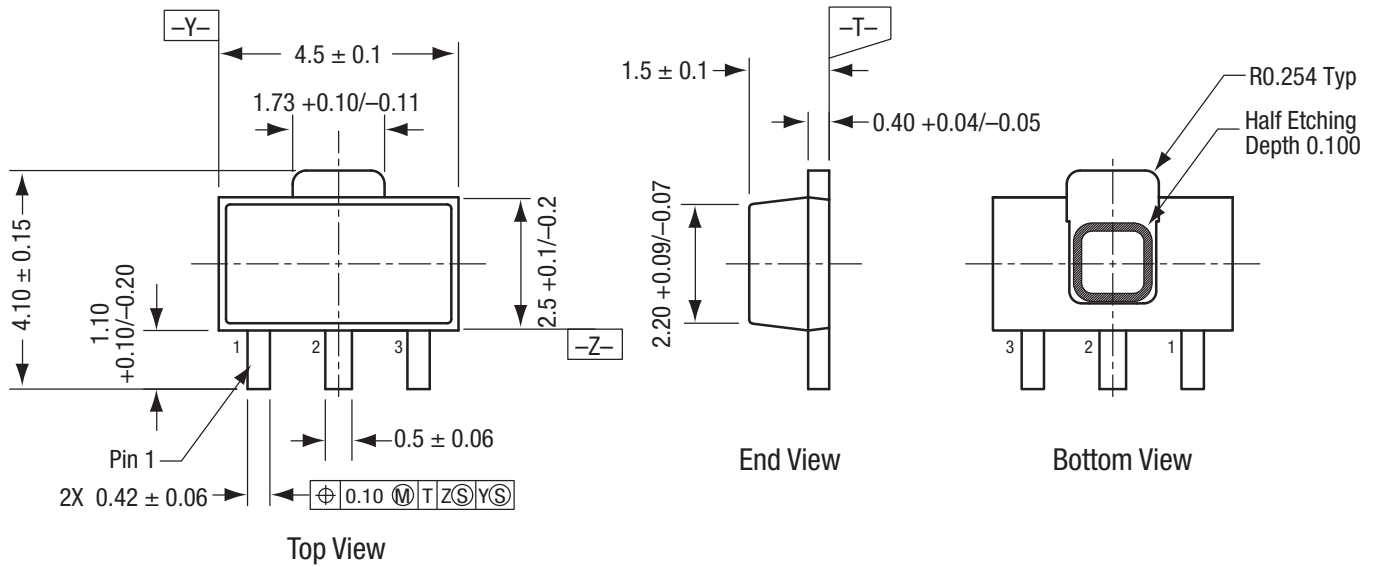

Figure 10. SKY65017-70LF PCB Layout Footprint



Notes:

1. All measurements are in millimeters.
2. Dimensioning and tolerancing according to ASME Y14.5M-1994.
3. Package dimension does not include mold protrusions or gate burrs.
Mold protrusions and gate burrs do not exceed 0.005" per end.
Body width dimension does not include interlead mold protrusions.
Interlead protrusions do not exceed 0.005" per side.
4. Leadwidth dimension does not include dambar protrusions.
Allowable protrusion does not exceed 0.002" total in excess of lead width dimension at maximum material condition.

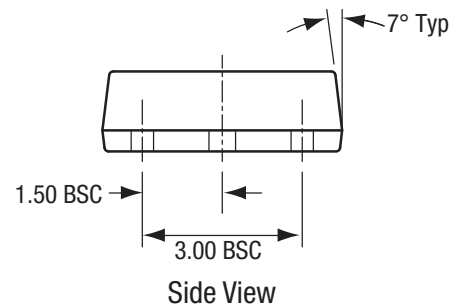
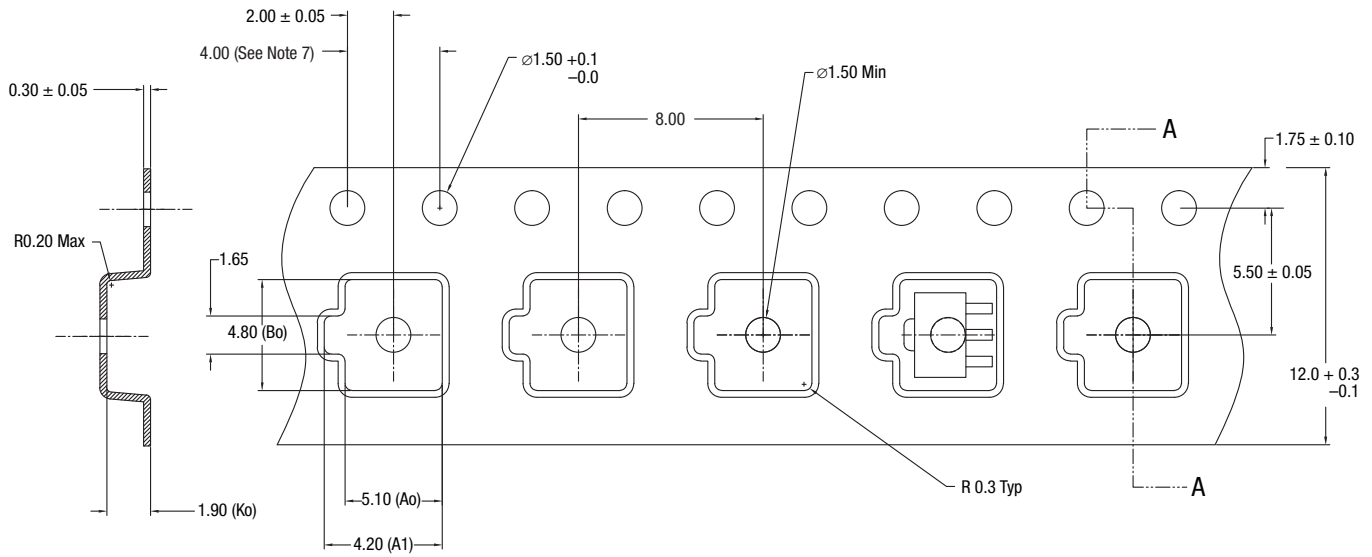

Figure 11. SKY65017-70LF Package Dimensions

DATA SHEET • SKY65017-70LF: CASCADABLE AMPLIFIER



Notes:

1. Carrier tapes must meet all requirements of Skyworks GP01-D233 procurement spec for tape and reel shipping.
2. Carrier tape material: black conductive polycarbonate or polystyrene.
3. Cover tape material: transparent conductive PSA.
Cover tape size: 9.2 mm width.
4. Typical ESD surface resistivity must meet all ESD requirements of Skyworks specified in GP01-D233.
5. Ao and Bo measurement point to be 0.30 mm from bottom pocket.
6. All measurements are in millimeters.
7. 10-sprocket hole pitch cumulative tolerance 0.2 mm.

200528-012

Figure 12. SKY65017-70LF Tape and Reel Dimensions