

**DATA SHEET**

# SKY65383-11: 2400 to 2483 MHz Transmit/Receive Front-End Module

**Applications**

- Automated meter reading
- Advanced metering infrastructure
- ISM systems

**Features**

- Transmit output power: +30 dBm
- High-efficiency PA
- Receive gain: 12 dB
- Receive noise figure: 2.5 dB
- Sleep mode current: <1  $\mu$ A
- Integrated control logic
- Small footprint, MCM (28-pin, 6 x 6 mm) package (MSL3, 260 °C per JEDEC J-STD-020)



Skyworks Green™ products are compliant with all applicable legislation and are halogen-free. For additional information, refer to *Skyworks Definition of Green™*, document number SQ04-0074.

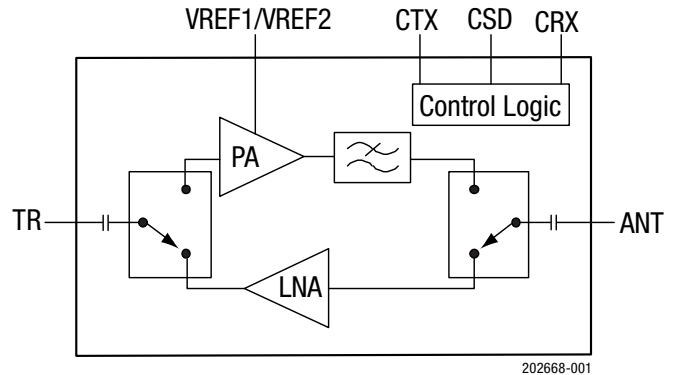

**Figure 1. SKY65383-11 Block Diagram**

**Description**

The Skyworks SKY65383-11 is a high-performance, transmit/receive (T/R) front-end module (FEM). The device provides a transmit power amplifier (PA) capable of transmitting greater than +30 dBm of output power at 36 percent power-added efficiency (PAE).

The receive chain features a low-loss, single-pole, double-throw (SPDT) switch and a high-performance low-noise amplifier (LNA) with a 2.5 dB noise figure (NF) and 12 dB receive gain.

All functionality can be controlled using a three-wire interface. The SKY65383-11 can be placed in a deep “sleep” mode, which draws less than 1  $\mu$ A of current.

The device is mounted in a 28-pin, 6 x 6 mm Multi-Chip Module (MCM) package, which allows for a highly manufacturable low-cost solution.

A block diagram of the SKY65383-11 is shown in Figure 1. The device package and pinout for the 28-pin MCM are shown in Figure 2. Signal pin assignments and functional pin descriptions are provided in Table 1.

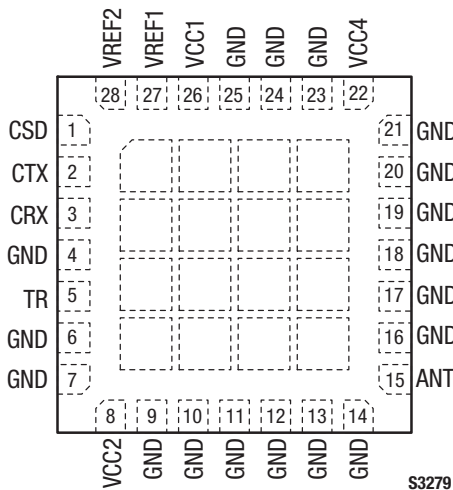

**Figure 2. SKY65383-11 Pinout (Top View)**

**Table 1. SKY65383-11 Signal Descriptions**

Pin	Name	Description	Pin	Name	Description
1	CSD	Transmit/receive mode digital control input	15	ANT	Antenna port (internally matched to 50 Ω)
2	CTX	Transmit/receive mode digital control input	16	GND	Ground
3	CRX	Transmit/receive mode digital control input	17	GND	Ground
4	GND	Ground	18	GND	Ground
5	TR	Transmit/receive port	19	GND	Ground
6	GND	Ground	20	GND	Ground
7	GND	Ground	21	GND	Ground
8	VCC2	LNA supply	22	VCC4	PA output stage supply
9	GND	Ground	23	GND	Ground
10	GND	Ground	24	GND	Ground
11	GND	Ground	25	GND	Ground
12	GND	Ground	26	VCC1	PA input stage supply
13	GND	Ground	27	VREF1	1 <sup>st</sup> stage PA reference voltage
14	GND	Ground	28	VREF2	2 <sup>nd</sup> stage PA reference voltage

### Technical Description

The SKY65383-11 consists of a complete T/R chain with T/R switches contained in the module. An SPDT switch selects between the receive and transmit paths. The module has a sleep mode to minimize power consumption.

Three digital input pins (CSD, CRX, and CTX) are used to select between transmit, receive, or shutdown mode.

### Transmit Path

The transmit path contains two SPDT high-isolation switches: one PA optimized for saturated performance and one integrated harmonic filter.

### Receive Path

The receive path contains two SPDT high-isolation switches and a high-performance LNA.

### Operation Mode Control

The SKY65383-11 operating modes are controlled by the three digital pins: CSD (pin 1), CTX (pin 2), and CRX (pin 3). The control logic is described in Table 2.

### Electrical and Mechanical Specifications

The absolute maximum ratings of the SKY65383-11 are provided in Table 3. Recommended operating conditions are specified in Table 4. Electrical specifications are provided in Tables 5, 6, and 7.

**Table 2. SKY65383-11 Operating Modes Truth Table<sup>1</sup>**

Operating Mode	CSD (Pin 1)	CTX (Pin 2)	CRX (Pin 3)	Typical Total Current (μA)
All off (sleep mode) <sup>2</sup>	0	0	0	See Table 5
Receive <sup>2</sup>	1	0	1	See Table 5
Transmit	1	1	0	See Table 5
Non-permissible	0	0	1	9
Non-permissible	0	1	0	9
Non-permissible	0	1	1	18
Non-permissible	1	0	0	9
Non-permissible	1	1	1	27

<sup>1</sup> See Recommended Operating Conditions (Table 4) for logic 0 and 1 characteristics.

<sup>2</sup> VREF1 and VREF2 must be 0 V.

**Table 3. SKY65383-11 Absolute Maximum Ratings<sup>1</sup>**

Parameter	Symbol	Minimum	Maximum	Units
PA input supply voltage	Vcc1		5.5	V
PA output supply voltage	Vcc4		5.5	V
PA input supply current	Icc1		300	mA
PA output supply current	Icc4		700	mA
Reference voltage	VREF1, VREF2		3	V
Thermal resistance	ΘJC		22	°C/W
Receive supply voltage	VCC2		3.6	V
Receive supply current	Icc2		7	mA
Receive RF input power @ ANT port	PIN_ANT		0	dBm
ANT port load VSWR in transmit mode	VSWR		10:1	-
Transmit mode duty cycle	TX_DUTY		50	%
Transmit RF input power @ TR port	PIN_TR		+6	dBm
Operating case temperature	TA	-40	+85	°C
Storage temperature	TSTG	-40	+125	°C
Junction temperature	TJ		+125	°C
Electrostatic discharge:	ESD			
Charged Device Module (CDM), Class 3			500	V
Human Body Model (HBM), Class 1A			250	V
Machine Model (MM), Class A			50	V

<sup>1</sup> Exposure to maximum rating conditions for extended periods may reduce device reliability. There is no damage to device with only one parameter set at the limit and all other parameters set at or below their nominal value.

**ESD HANDLING:** *Although this device is designed to be as robust as possible, electrostatic discharge (ESD) can damage this device. This device must be protected at all times from ESD when handling or transporting. Static charges may easily produce potentials of several kilovolts on the human body or equipment, which can discharge without detection. Industry-standard ESD handling precautions should be used at all times.*

**Table 4. SKY65383-11 Recommended Operating Conditions**

Parameter	Symbol	Min	Typ	Max	Units
Transmit frequency range	f	2400		2483	MHz
PA supply voltage	VCC1, VCC4	3.0	3.3	4.0	V
PA reference voltage	VREF1, VREF2	2.75	2.85	2.95	V
Receive supply	VCC4	2.7	3.3	3.6	V
Control logic voltage:					
High	V <sub>IH</sub>	1.65		VCC1	V
Low	V <sub>IL</sub>	0		0.30	V
Control logic current:					
High	I <sub>IH</sub>		9		μA
Low	I <sub>IL</sub>		0.1		μA

**Table 5. SKY65383-11 DC Electrical Specifications<sup>1</sup>**

(VCC1 = VCC2 = VCC4 = 3.3 V, VREF1 = VREF2 = 2.85 V, T<sub>A</sub> = +25 °C, Unless Otherwise Noted)

Parameter	Symbol	Test Condition	Min	Typ	Max	Units
VCC2 current, receive mode	I <sub>CC2</sub>	VREF1 = VREF2 = 0 V		5		mA
Quiescent current, transmit mode	I <sub>CQ</sub>	Current through VCC1 + VCC4		240		mA
Operating current, transmit mode	I <sub>OP</sub>	P <sub>OUT</sub> = +30 dBm, current through VCC1 + VCC4		820		mA
PA reference current 1, transmit mode	I <sub>REF1</sub>			11	12	mA
PA reference current 2, transmit mode	I <sub>REF2</sub>			1	2	mA
All VCC current shutdown mode	I <sub>OFF</sub>	VREF1 = VREF2 = 0 V			1	μA

<sup>1</sup> Performance is guaranteed only under the conditions listed in this table.

**Table 6. SKY65383-11 Electrical Specifications: Receive Mode<sup>1</sup>**

(VCC1 = VCC2 = VCC4 = 3.3 V, VREF1 = VREF2 = 0 V, T<sub>A</sub> = +25 °C, Unless Otherwise Noted)

Parameter	Symbol	Test Condition	Min	Typ	Max	Units
<b>ANT to Receive Output</b>						
Small signal gain	G			12		dB
Noise figure	NF			2.5		dB
1 dB input compression point	IP1dB	1 dB gain compression		-12		dBm
Third order input intercept point	IIP3	P <sub>M</sub> = -30 dBm/tone, 200 kHz spacing		-3		dBm
Input return loss	S11	@ ANT port		-10		dB
Output return loss	S22	@ TR port		-10		dB
Power-on time <sup>3</sup>	T <sub>PUP</sub>			5		μs
Transmit to receive switching time <sup>2,3</sup>				4		μs

<sup>1</sup> Performance is guaranteed only under the conditions listed in this table.

<sup>2</sup> This assumes that the TX and RX signal transitions are within 100 ns of each other.

<sup>3</sup> Not production tested. Guaranteed by characterization.

**Table 7. SKY65383-11 Electrical Specifications: Transmit Mode<sup>1</sup>**  
**(VCC1 = VCC2 = VCC4 = 3.3 V, VREF1 = VREF2 = 2.85 V, T<sub>A</sub> = +25 °C, Unless Otherwise Noted)**

Parameter	Symbol	Test Condition	Min	Typ	Max	Units
<b>Transmit to ANT Path</b>						
Output power	P <sub>OUT</sub>			+30		dBm
Small signal gain	S <sub>21</sub>	P <sub>IN</sub> = -20 dBm		34		dB
Power-added efficiency	PAE	Measured at ANT port		36		%
2 <sup>nd</sup> harmonic <sup>3</sup>	2fo				-42	dBm/MHz
3 <sup>rd</sup> to 10 <sup>th</sup> harmonics <sup>3</sup>	3fo to 10fo				-42	dBm/MHz
Input return loss	S <sub>11</sub>	@ TR port		-7.5		dB
Output return loss	S <sub>22</sub>	@ ANT port		-10		dB
Non-harmonic spurious <sup>3</sup>	PSPUR	VSWR 6:1, all phases			-40	dBm
Power-on time <sup>3</sup>	T <sub>PUP</sub>			5		μs
Receive to transmit switching time <sup>2,3</sup>				800		ns
<b>ANT to Receive Path</b>						
Isolation	S <sub>21</sub>	Isolation between ANT and TR ports when in transmit mode	25	30		dB

<sup>1</sup> Performance is guaranteed only under the conditions listed in this table.

<sup>2</sup> This assumes that the TX and RX signal transitions are within 100 ns of each other.

<sup>3</sup> Not production tested. Guaranteed by characterization.

## Evaluation Board Description

The SKY65383-11 Evaluation Board is used to test the performance of the SKY65383-11 T/R FEM. A typical application schematic diagram is provided in Figure 3. A photograph of the Evaluation Board is shown in Figure 4. Component values for the SKY65383-11 Evaluation Board are listed in Table 8.

## Package Dimensions

The PCB layout footprint for the SKY65383-11 is provided in Figure 5. Package dimensions are shown in Figure 6, and tape and reel dimensions are provided in Figure 7.

## Package and Handling Information

Since the device package is sensitive to moisture absorption, it is baked and vacuum packed before shipping. Instructions on the shipping container label regarding exposure to moisture after the container seal is broken must be followed. Otherwise, problems related to moisture absorption may occur when the part is subjected to high temperature during solder assembly.

The SKY65383-11 is rated to Moisture Sensitivity Level 3 (MSL3) at 260 °C. It can be used for lead or lead-free soldering. For additional information, refer to Skyworks Application Note, *PCB Design and SMT Assembly/Rework Guidelines for MCM-L Packages*, document number 101752.

Care must be taken when attaching this product, whether it is done manually or in a production solder reflow environment. Production quantities of this product are shipped in a standard tape and reel format.

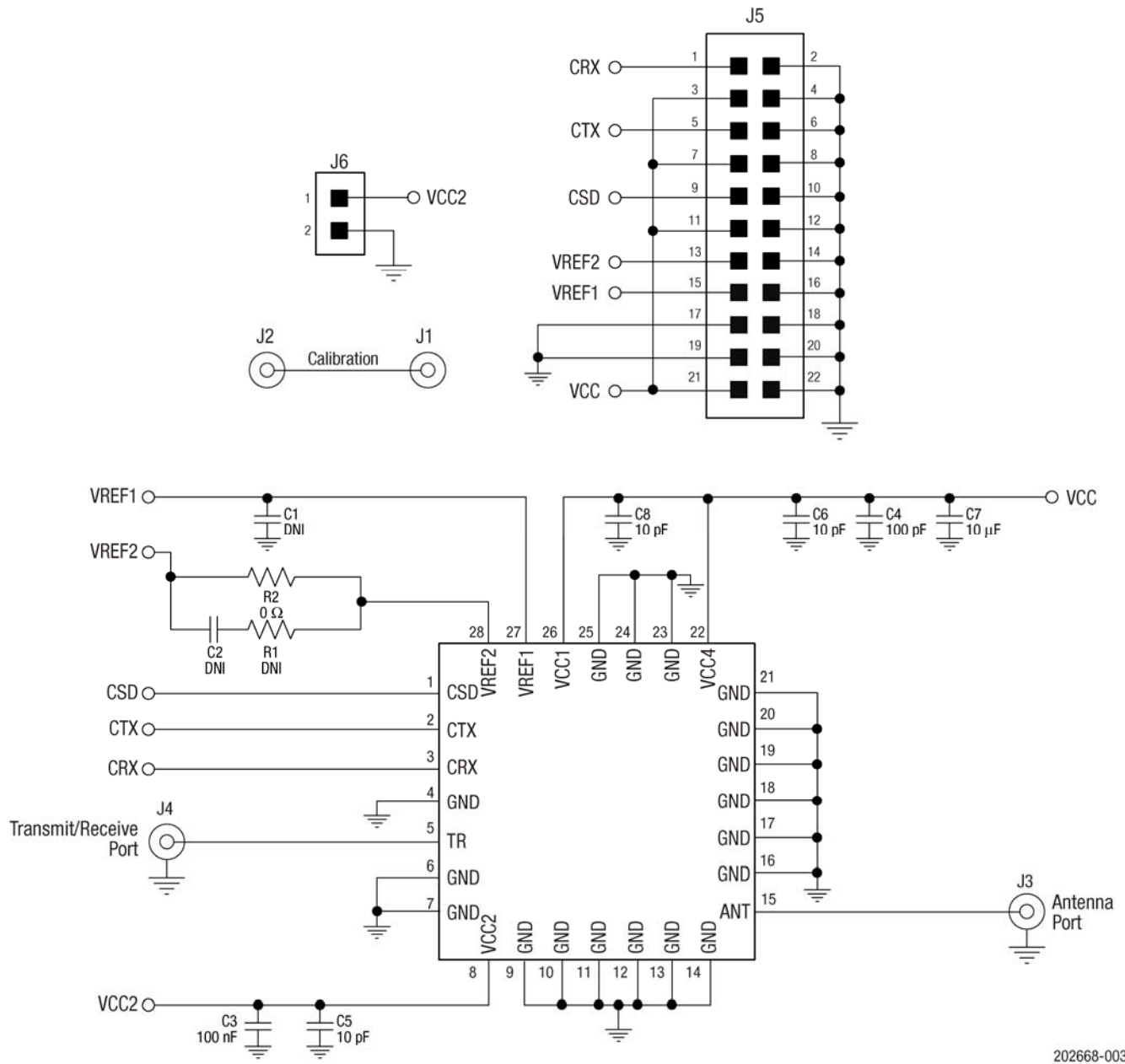

Figure 3. SKY65383-11 Typical Application Schematic

202668-003

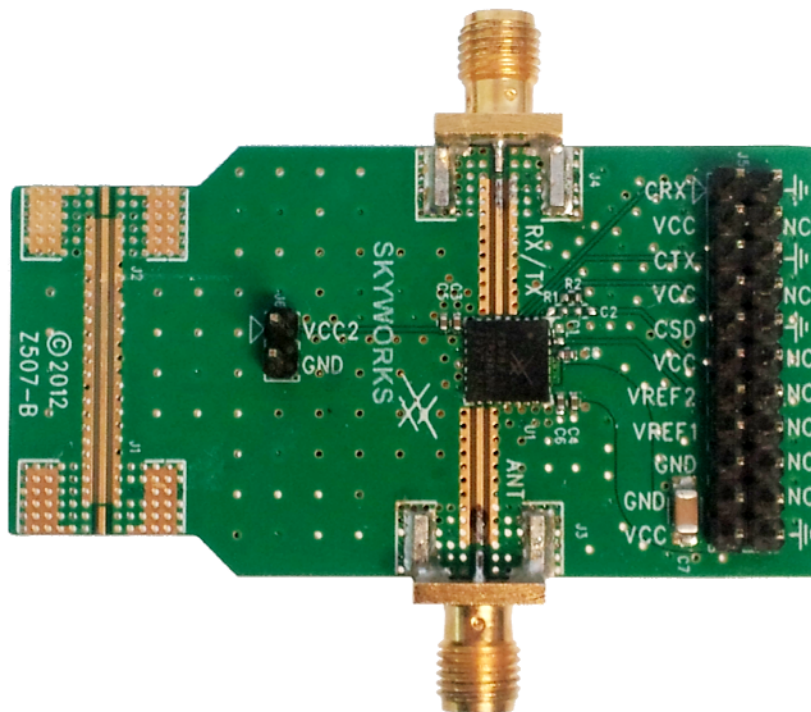
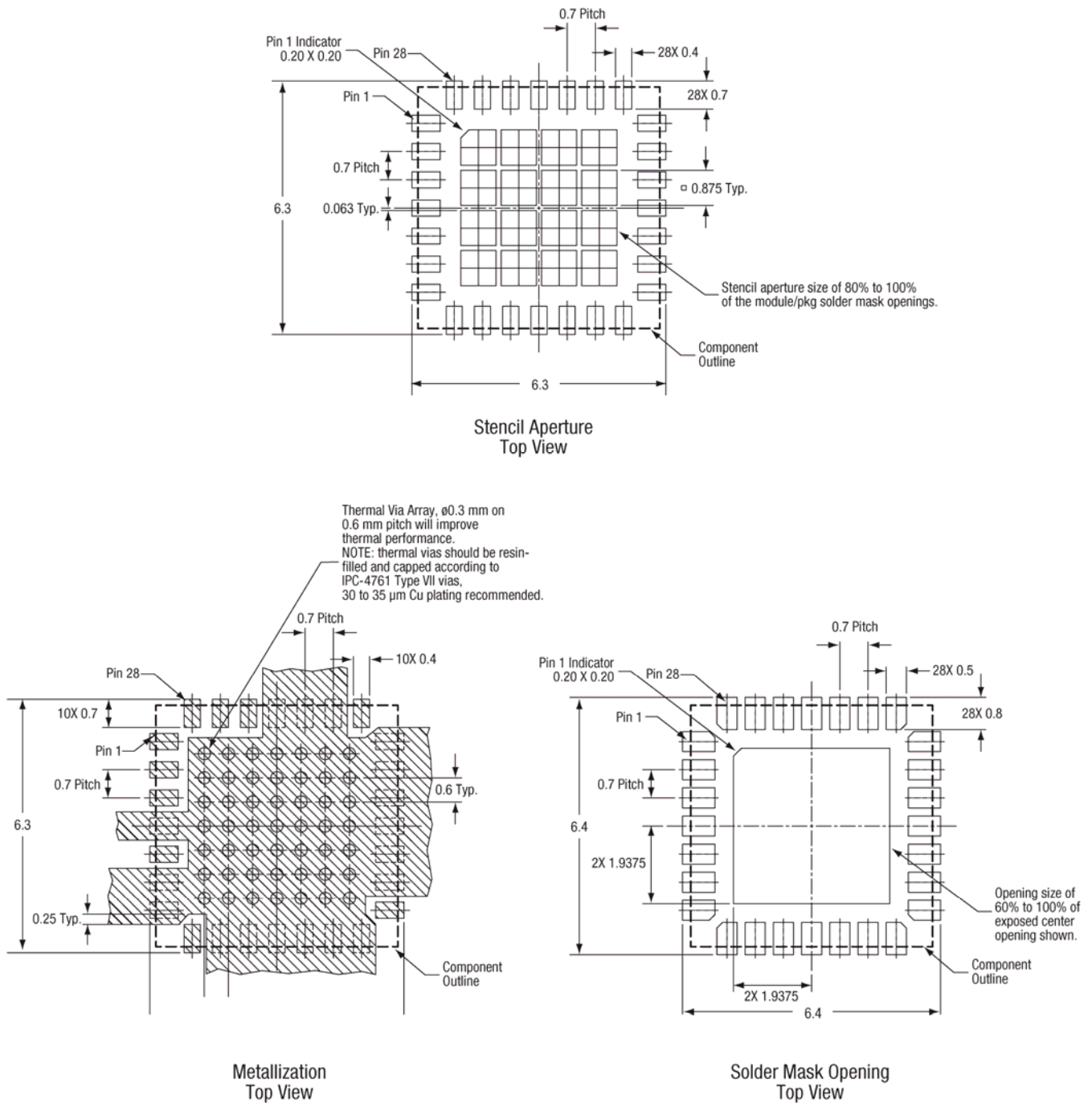

Figure 4. SKY65383-11 Evaluation Board

Table 8. SKY65383-11 Evaluation Board Bill of Materials (BOM)

Component	Size	Value	Vendor	Mfr Part Number	Comments
C1, C2	DNI	-	-	-	-
C3, C4	0402	100 nF	Murata	GRM155R61A104KA01	Multilayer ceramic
C5, C6, C8	0402	10 pF	Murata	GRM1555C1H100JZ01	Multilayer ceramic
C7	1206	10 $\mu$ F	Murata	GRM31CR71C106KAC7L	Multilayer ceramic
J1, J2	End launch	DNI/SMA	Johnson Components	142-0701-851	SMA end launch straight jack receptacle, tab contact
J3, J4	End launch	SMA	Johnson Components	142-0701-851	SMA end launch straight jack receptacle, tab contact
J5	100 mil	11x2	Molex	10-89-1221	100 mil header
J6	100 mil	2x1	Samtec	TSW-102-07-G-S	100 mil header
R1	DNI	-	-	-	-
R2	0402	0 $\Omega$	Panasonic	ERJ2GE0R00	Thick film chip resistor



All dimensions are in millimeters

202668-005

Figure 5. SKY65383-11 PCB Layout Footprint



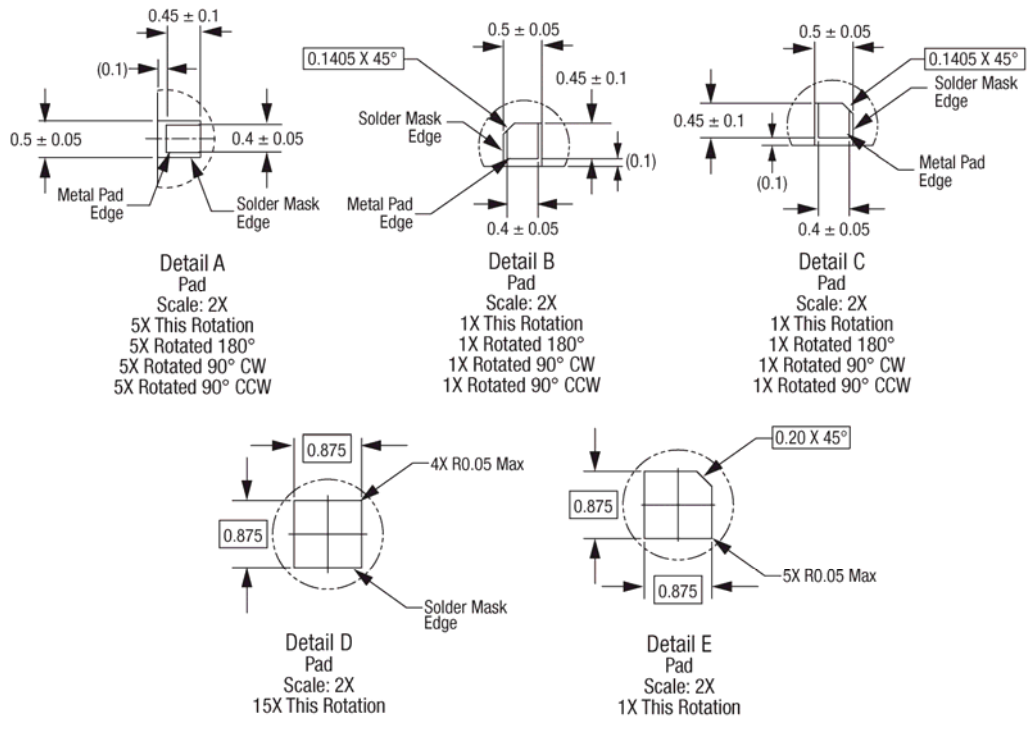
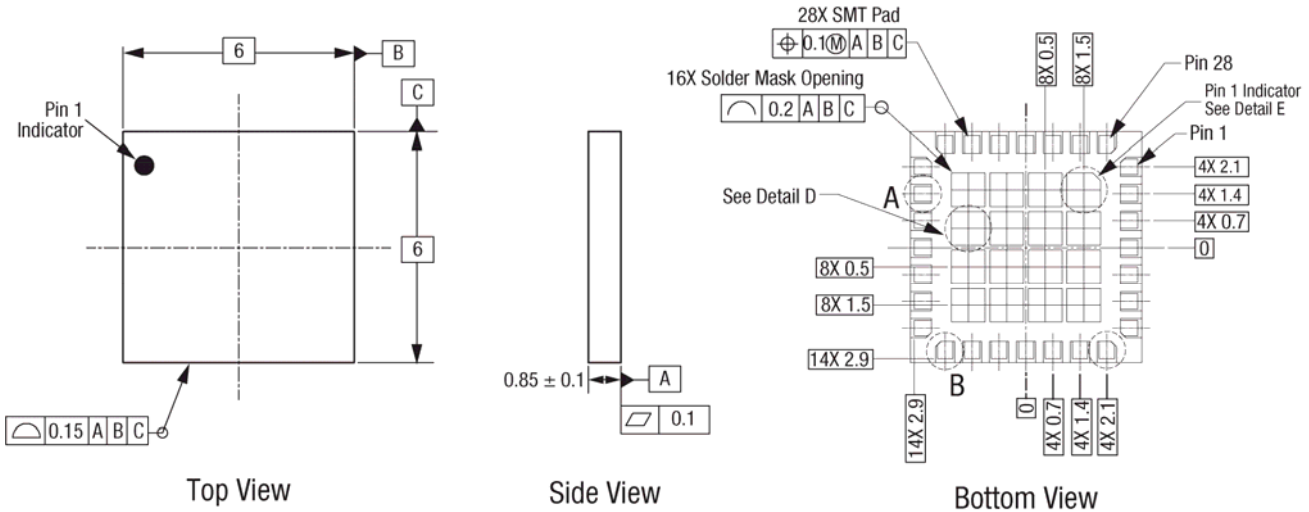

- Notes:
1. All measurements are in millimeters.
  2. Dimensioning and tolerancing according to ASME Y14.5M-1994.
  3. Pad definitions per details on drawing.

202668-006

Figure 6. SKY65383-11 Package Dimensions

**DATA SHEET • SKY65383-11: TRANSMIT/RECEIVE FRONT-END MODULE**

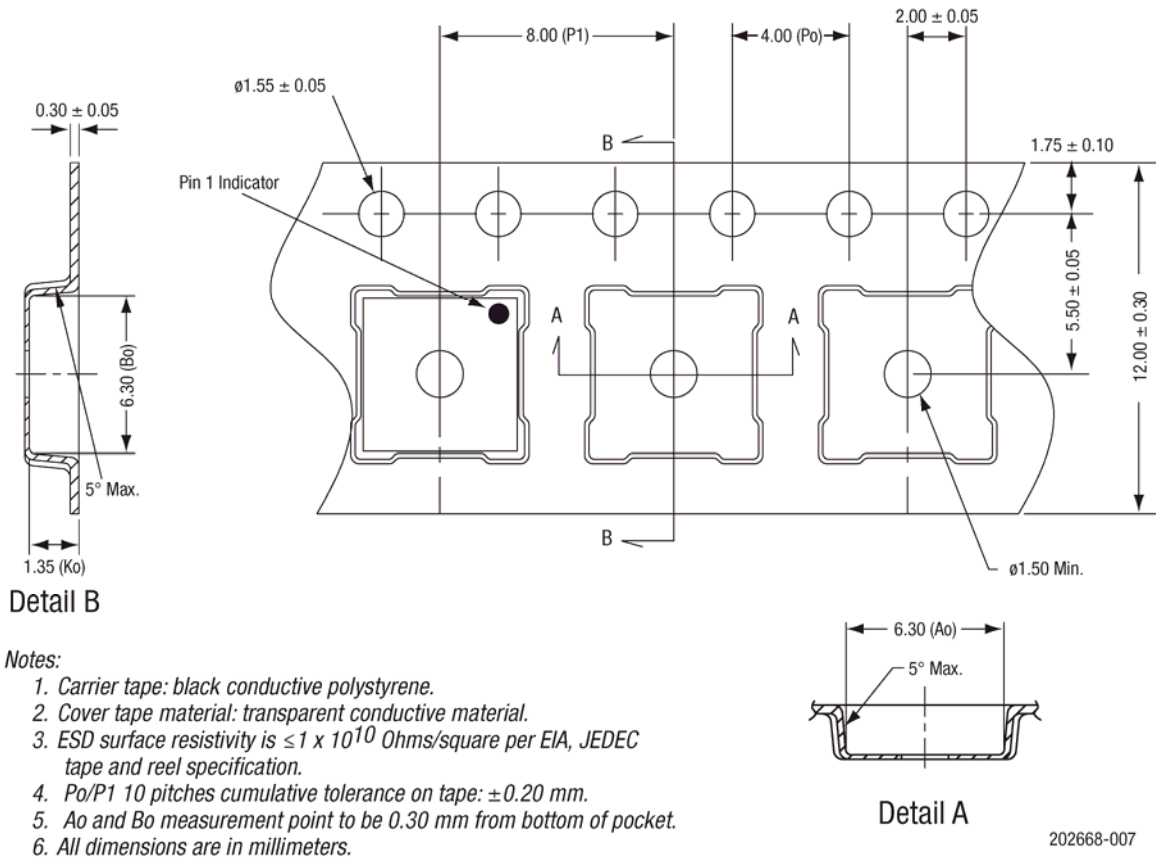

**Figure 7. SKY65383-11 Tape and Reel Dimensions**