

DATA SHEET

SKY65981-11: 5 GHz, 802.11ac/n Low-Noise Amplifier

Applications

- IEEE 802.11ac/n WLANs
- 5 GHz ISM radios
- SmartPhones
- Notebooks, netbooks, tablets
- Access points, routers, gateways
- Wireless video systems

Features

- Ultra-low Noise Figure
- 4.9 GHz to 5.9 GHz operation
- Enable/disable/bypass modes
- High IIP3
- High gain
- 2.8 V to 3.6 V single-supply operation
- QFN (6-pin, 1.5 x 1.5 mm) package (MSL1, 260 °C per JEDEC J-STD-020)



Skyworks Pb-free products are compliant with all applicable legislation. For additional information, refer to *Skyworks Definition of Lead (Pb)-Free*, document number SQ04-0073.

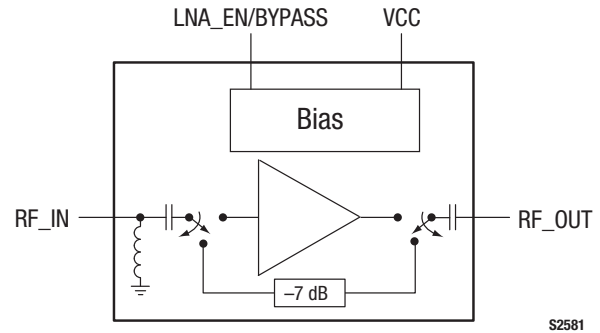

Figure 1. SKY65981-11 LNA Block Diagram

Description

The SKY65981-11 is an ultra Low-Noise Amplifier (LNA) intended for 5 GHz, IEEE 802.11ac/n wireless receiver applications. Its industry-leading Noise Figure (NF), together with high linearity, make it ideal as a first-stage LNA in IEEE 802.11ac/n Wireless Local Area Network (WLAN) radios.

Operating with a single supply voltage, the SKY65981-11 consumes only 12 mA of current. The device includes a bypass mode for near field applications and to save power when the receiver is inactive.

The tiny package footprint of the SKY65981-11, requiring only four external components, enables the industry's smallest PCB area needed to implement a fully-matched 5 GHz LNA.

A block diagram of the SKY65981-11 is shown in Figure 1. The device package and pinout for the 6-pin Quad Flat No-Lead (QFN) are shown in Figure 2.

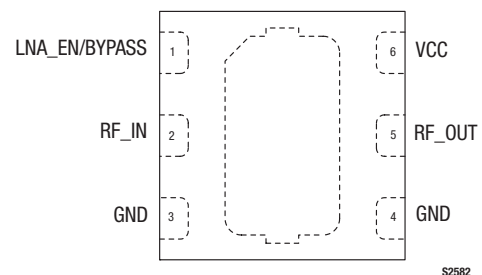

Figure 2. SKY65981-11 Pinout – 6-Pin QFN Package (Top View)

Technical Description

The SKY65981-11 is fully matched at 50 Ω and requires only a simple bypass circuit on pin 6 (VCC). The bypass/shutdown mode is achieved by switching the LNA_EN signal (pin 1) to 0 V.

Package and Handling Information

Instructions on the shipping container label regarding exposure to moisture after the container seal is broken must be followed. Otherwise, problems related to moisture absorption may occur when the part is subjected to high temperature during solder assembly.

The SKY65981-11 is rated to Moisture Sensitivity Level 1 (MSL1) at 260 °C. It can be used for lead or lead-free soldering. For additional information, refer to the Skyworks Application Note, *Solder Reflow Information*, document number 200164.

Care must be taken when attaching this product, whether it is done manually or in a production solder reflow environment.

Production quantities of this product are shipped in a standard tape and reel format.

Electrical and Mechanical Specifications

Signal pin assignments and functional pin descriptions are described in Table 1. The absolute maximum ratings of the SKY65981-11 are provided in Table 2. The recommended operating conditions are specified in Table 3 and electrical specifications are provided in Table 4.

Performance characteristics for the SKY65981-11 are illustrated in Figures 3 through 9.

An application schematic diagram for the SKY65981-11 is shown in Figure 10. The PCB footprint drawing for the SKY65981-11 is provided in Figure 11. Typical part markings are shown in Figure 12. The package dimensions for the 6-pin QFN are shown in Figure 13, and the tape and reel dimensions are provided in Figure 14.

Table 1. SKY65981-11 Signal Descriptions

Pin	Name	Description
1	LNA_EN/BYPASS	LNA enable (when pulled high) or bypass (when pulled low) control input
2	RF_IN	LNA RF input
3	GND	Ground
4	GND	Ground
5	RF_OUT	LNA RF output
6	VCC	Supply voltage for LNA

Table 2. SKY65981-11 Absolute Maximum Ratings (Note 1)

Parameter	Symbol	Minimum	Maximum	Units
Supply voltage	VCC	0	3.6	V
DC voltage at control ports	VENABLE	0	3.6	V
Power into LNA inputs	P _{IN} , LNA		+10	dBm
Operating temperature	T _A	-40	+85	°C
Storage temperature	T _{STG}	-40	+125	°C

Note 1: Exposure to maximum rating conditions for extended periods may reduce device reliability. There is no damage to device with only one parameter set at the limit and all other parameters set at or below their nominal values. Exceeding any of the limits listed here may result in permanent damage to the device.

CAUTION: Although this device is designed to be as robust as possible, Electrostatic Discharge (ESD) can damage this device. This device must be protected at all times from ESD. Static charges may easily produce potentials of several kilovolts on the human body or equipment, which can discharge without detection. Industry-standard ESD precautions should be used at all times.

Table 3. SKY65981-11 Recommended Operating Conditions (@ +25 °C, VCC = 3.3 V)

Parameter	Symbol	Minimum	Typical	Maximum	Units
Supply voltage	VCC	0		3.6	V
RF frequency range	f	5.15		5.85	GHz
Operating temperature range	T _A	-40		+85	°C
DC voltage at control port:					
High	V _{ENABLE_H}	1.8		3.6	V
Low	V _{ENABLE_L}	0		0.2	V

Table 4. SKY65981-11 Electrical Characteristics (Note 1)
(VCC = 3.3 V, T_A = +25 °C, f = 5.15 to 5.85 GHz, V_{ENABLE} = 3.3 V, Unless Otherwise Noted)

Parameter	Symbol	Test Conditions	Minimum	Typical	Maximum	Units
Enable Mode (LNA_EN = 3.3 V)						
Gain	IS211		11	13		dB
Gain flatness across 80 MHz channel	IS211			0.5		dB
Out-of-band gain @ 2.462 GHz	S21_2.462			-6		dB
Noise Figure	NF			1.5	1.7	dB
3 rd Order Input Intercept Point	IIP3			+7		dBm
In-band 1 dB compression point at input	IP1dB			-1.5		dBm
Out-of-band (2.462 GHz injected signal) 1 dB compression point at input	IP1dB			+3		dBm
Input return loss	IS111	Z _{s/L} = 50 Ω	7			dB
Output return loss	IS221	Z _{s/L} = 50 Ω	10			dB
Reverse isolation	S12			-20		dB
Maximum RF input (compliant)				-10		dBm
Maximum RF input (no damage)				+10		dBm
Drain current	I _{SUBCC}			12	15	mA
Control enable current	I _{EN}				100	μA
Bypass Mode (LNA_EN = 0 V)						
Gain	S21			-7		dB
Gain flatness across 80 MHz channel	IS211			0.5		dB
Noise Figure	NF			7		dB
1 dB Input Compression Point	IP1dB			+18.5		dBm
Input return loss	IS111		7			dB
Output return loss	IS221		12			dB
Maximum RF input with harmonic < -50 dBm/MHz (Note 2)					+11	dBm
Switching speed: LNA to bypass mode and bypass mode to LNA	t _s				300	ns

Note 1: Performance is guaranteed only under the conditions listed in this Table.

Note 2: Harmonic leakage is measured at RF_IN port.

Typical Performance Characteristics

($V_{CC} = 3.3\text{ V}$, $T_A = +25\text{ }^\circ\text{C}$, $f = 4.90\text{ to }5.85\text{ MHz}$, $V_{ENABLE} = 3.3\text{ V}$, Unless Otherwise Noted)

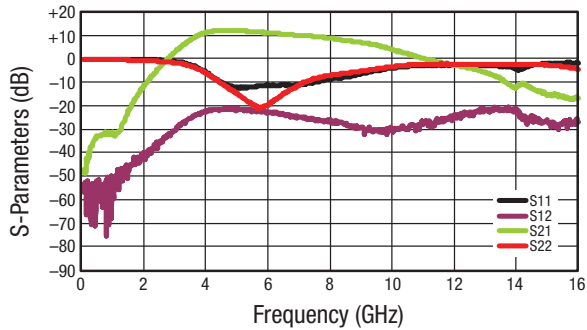

Figure 3. Broadband S-Parameters vs Frequency ("On" State)

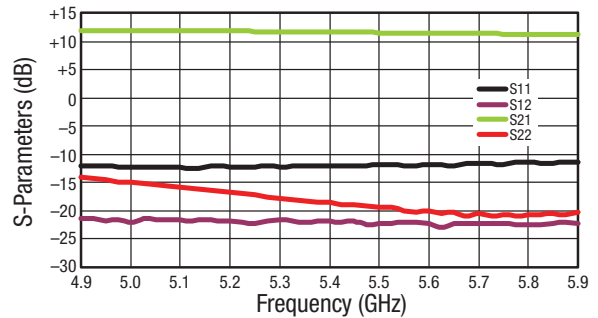

Figure 4. Narrow Band S-Parameters vs Frequency ("On" State)

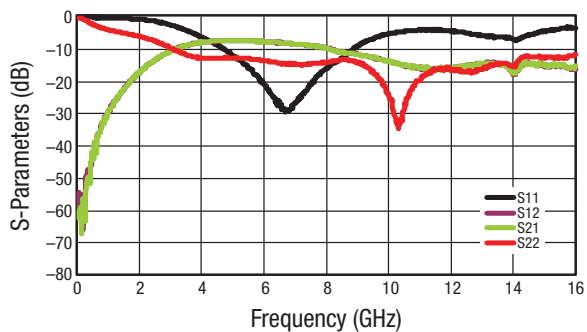

Figure 5. Broadband S-Parameters vs Frequency (Bypass Mode)

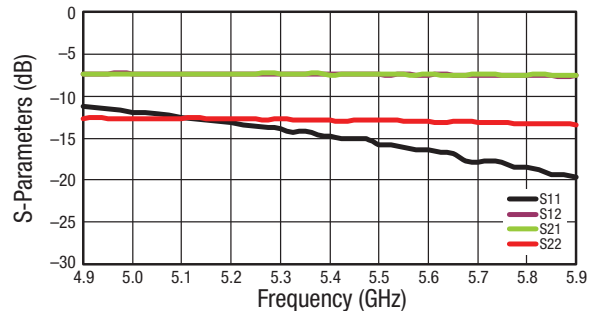

Figure 6. Narrow Band S-Parameters vs Frequency (Bypass Mode)

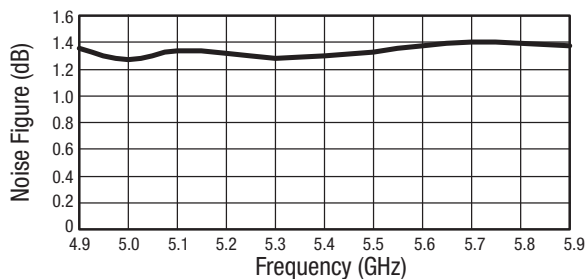

Figure 7. Noise Figure vs Frequency

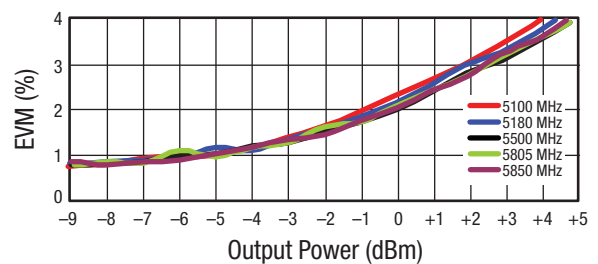

Figure 8. EVM vs Output Power Over Frequency

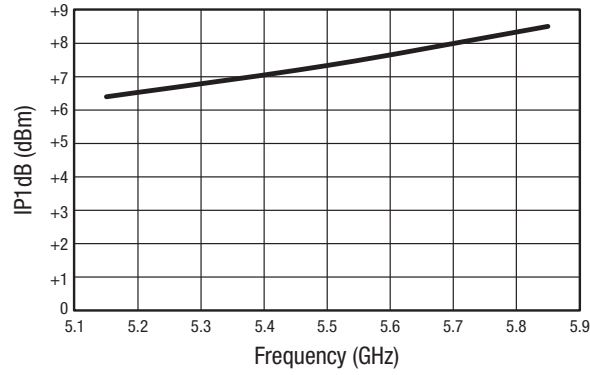
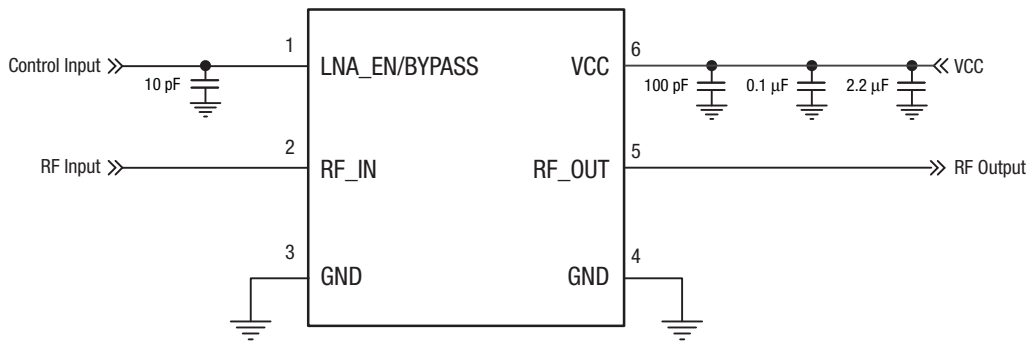
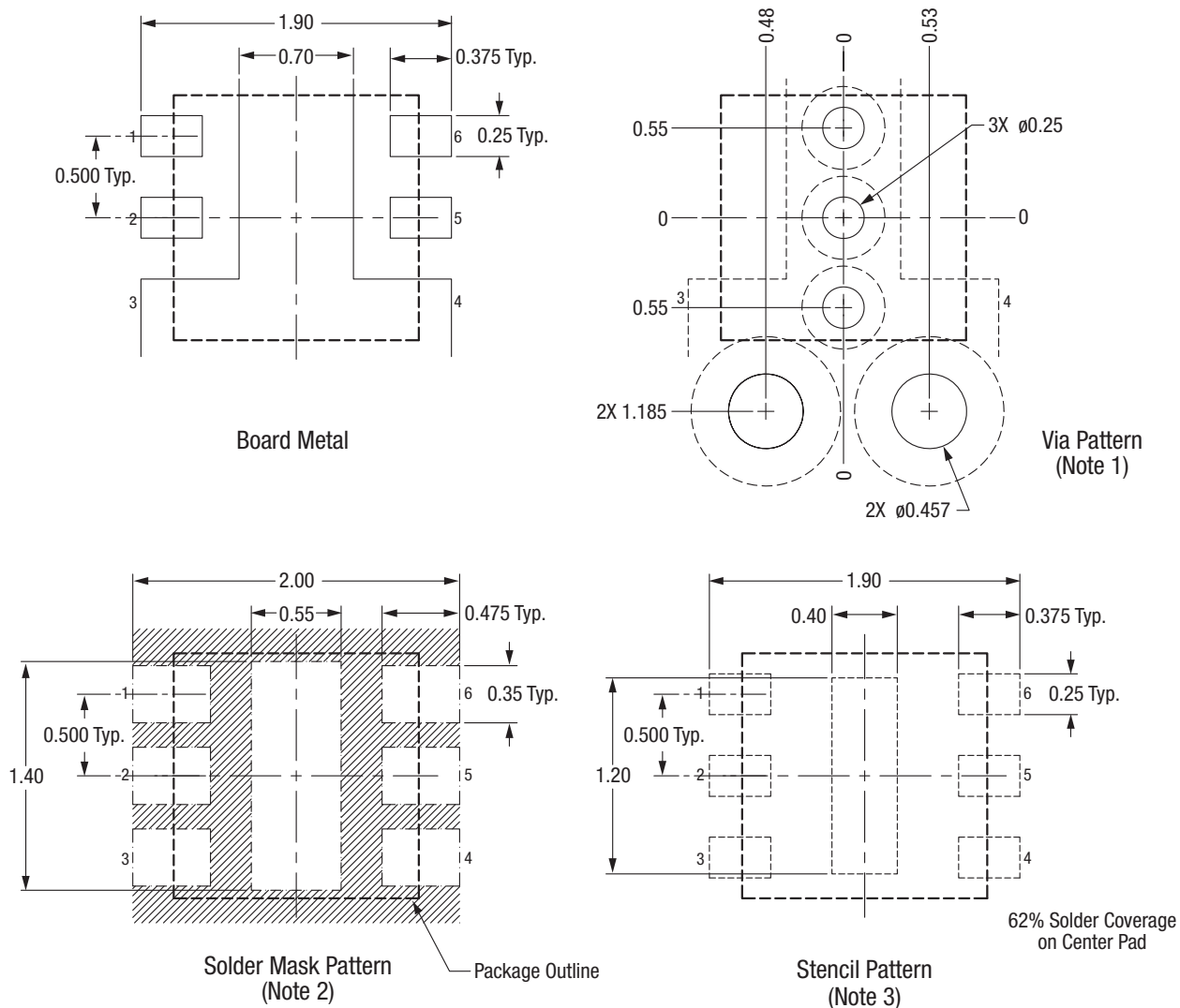

Figure 9. IP1dB vs Frequency



S2672

Figure 10. SKY65981-11 Schematic Diagram



NOTES:

1. Via hole recommendations:
0.025 mm Cu via wall plating (minimum),
via holes to be plated shut or plugged and
capped, both sides.
2. Soldermask recommendations:
Contact board fabricator for recommended
soldermask offset and tolerance.
3. Stencil recommendations:
0.10 mm stencil thickness, laser cut apertures,
trapezoidal walls and rounded corners offer
better paste release.

Dimension and tolerancing according to ASME Y14.5M-1994.
Unless specified, dimensions are symmetrical about center lines.
All dimensions are in millimeters.

S3352

Figure 11. SKY65981-11 PCB Layout Footprint (Top View)

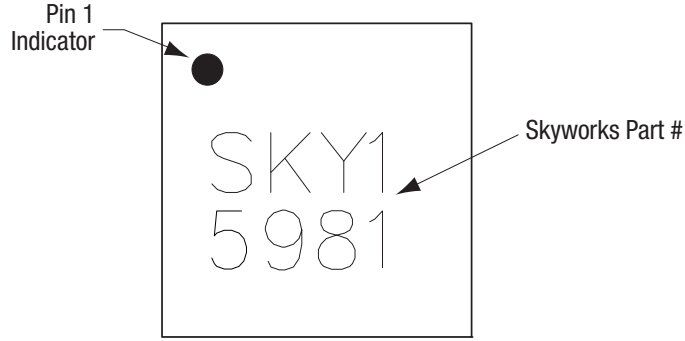
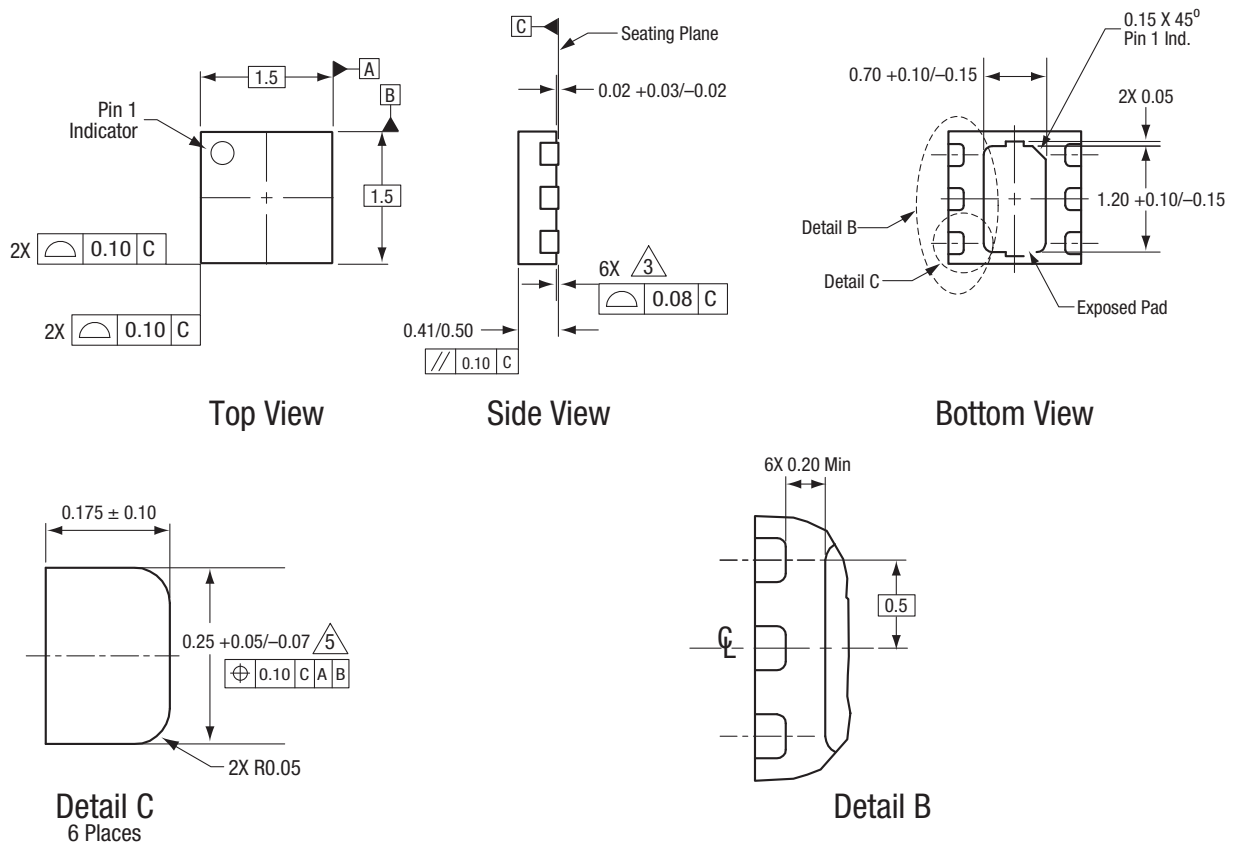

Figure 12. Typical Part Markings (Top View)



All measurements are in millimeters.
 Dimensioning and tolerancing according to ASME Y14.5M-1994.
 Coplanarity applies to the exposed heat sink slug as well as the terminals.
 Plating requirement per source control drawing (SCD) 2504.
 Dimension applies to metallized terminal and is measured between 0.15 mm and 0.30 mm from terminal tip.

S1350

Figure 13. SKY65981-11 6-Pin QFN Package Dimensions

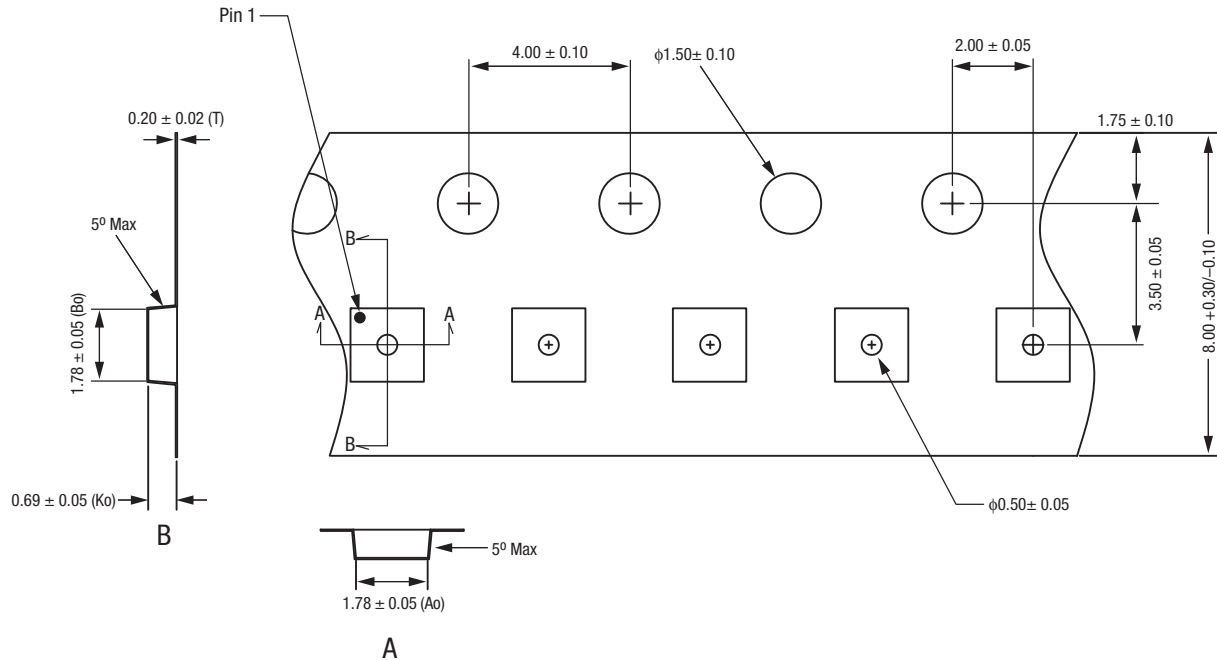

Notes:

1. Carrier tape: black conductive polycarbonate or polystyrene.
2. Cover tape material: transparent conductive PSA.
3. Cover tape size: 5.4 mm width.
4. All measurements are in millimeters.

S1382a

Figure 14. SKY65981-11 Tape and Reel Dimensions