

DATA SHEET

SKY66115-11: 400 to 510 MHz Front-End Module for Range Extension Applications

Applications

- Range extender
- Smart meters, tracking, and RFID

Features

- Transmit output power: +20 dBm
- 2.5 V to 3.6 V supply operation
- Low power consumption
- Rx bypass
- Small footprint (16-pin, 4 x 4 mm) MCM package (MSL3, 260 °C per JEDEC J-STD-020)



Skyworks Green™ products are compliant with all applicable legislation and are halogen-free. For additional information, refer to *Skyworks Definition of Green™*, document number SQ04-0074.

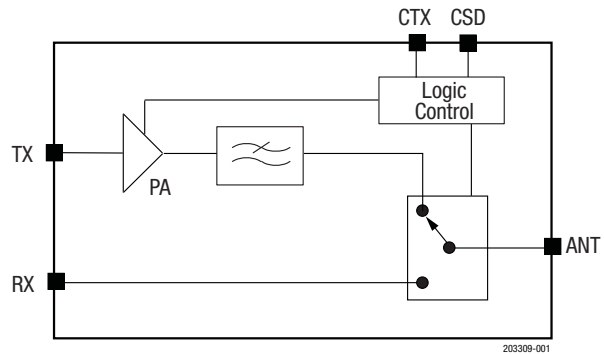

Figure 1. SKY66115-11 Block Diagram

Description

The SKY66115-11 is a highly integrated front-end module (FEM) designed for range extension and smart metering applications in the 400 to 510 MHz range.

The device is provided in a 4 x 4 mm, 16-pin MCM package. A functional block diagram is shown in Figure 1. The device package and pinout are shown in Figure 2. Table 1 lists the pin-assignments and signal descriptions.

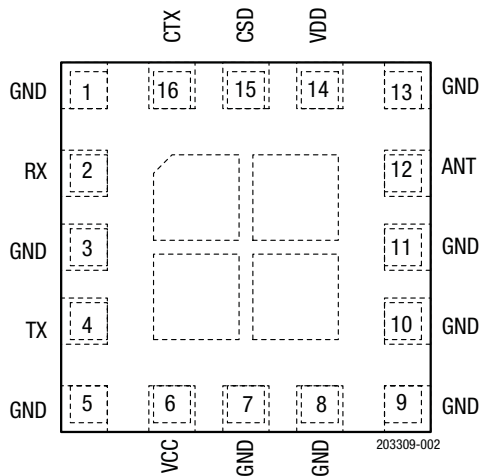

Figure 2. SKY66115-11 Pinout (Top View)

Table 1. SKY66115-11 Signal Descriptions

Pin	Name	Description	Pin	Name	Description
1	GND	Ground	9	GND	Ground
2	RX	Receive port	10	GND	Ground
3	GND	Ground	11	GND	Ground
4	TX	Transmit port	12	ANT	Antenna port
5	GND	Ground	13	GND	Ground
6	VCC	Positive power supply	14	VDD	Positive power supply
7	GND	Ground	15	CSD	Shutdown control signal
8	GND	Ground	16	CTX	TX/RX control signal

Technical Description

The SKY66115-11 consists of a complete T/R chain with a T/R switch contained in the module. The module has a shutdown mode to minimize power consumption.

Transmit Path

The transmit path contains an amplifier optimized for saturated performance. The output is internally matched for optimum output power and efficiency into a 50 Ω load impedance. The output is passed through a harmonic filter before being fed through the switch. The input provides a good return loss into a 50 Ω source impedance.

Operation Mode Control

The operating modes are controlled by the two digital pins (CSD and CTX, pins 15 and 16, respectively). The control logic truth table is provided in Table 8.

Electrical and Mechanical Specifications

The absolute maximum ratings of the SKY66115-11 are provided in Table 2. Recommended operating conditions are specified in Table 3 and electrical specifications are provided in Tables 4 through 7. Table 8 shows the mode logic truth table.

Typical performance characteristics are shown in Figures 3 through 8.

Table 2. SKY66115-11 Absolute Maximum Ratings¹

Parameter	Symbol	Test Condition	Minimum	Maximum	Units
Supply voltage	VCC		2.5	3.8	V
Control voltages	VDD, VCSD, VCTX		-0.2	VCC	V
RF input power, receive mode	PIN_RX	Rx mode at ANT		+30	dBm
RF input power, transmit mode	PIN_TX	Tx mode at TX		10	dBm
Voltage standing wave ratio	VSWR			10:1	
Operating temperature	TA		-40	+85	C
Storage temperature	TSTG		-65	+150	C
Transmit duty cycle				50	%

¹ Exposure to maximum rating conditions for extended periods may reduce device reliability. There is no damage to device with only one parameter set at the limit and all other parameters set at or below their nominal value. Exceeding any of the limits listed here may result in permanent damage to the device.

ESD HANDLING: *Although this device is designed to be as robust as possible, electrostatic discharge (ESD) can damage this device. This device must be protected at all times from ESD when handling or transporting. Static charges may easily produce potentials of several kilovolts on the human body or equipment, which can discharge without detection. Industry-standard ESD handling precautions should be used at all times.*

Table 3. SKY66115-11 Recommended Operating Conditions

Parameter	Symbol	Min	Typ	Max	Units
Frequency ¹	f	400		510	MHz
Supply voltages	VCC, VDD	2.5	3.3	3.6	V
Control voltages	VCSD, VCTX	0		VDD	V
Digital input voltage (CSD and CTX):					
Logic 0	VLOW	0		0.45	V
Logic 1	VHIGH	2.8		VDD	V

¹ Below 470 MHz, an external harmonic filter is required.

Table 4. SKY66115-11 Electrical Specifications: DC Characteristics¹
(VCC = VDD = 3.3 V, TA= +25 °C, No RF Input Power, Unless Otherwise Noted)

Parameter	Symbol	Test Condition	Min	Typ	Max	Units
Rx current	ICQ_RX_VDD	Rx Mode		3		μA
Tx quiescent current, VDD	ICQ_TX_VDD	Tx Mode		5		mA
Tx quiescent current, VCC	ICQ_TX_VCC	Tx Mode		40		mA
Tx operating current	IOP_TX_VCC	Tx Mode, POUT = +20 dBm		67		mA
Sleep current, VDD	IDD_OFF	Sleep Mode		3		μA
Sleep current, VCC	ICC_OFF	Sleep Mode		0.04	1	μA
Digital input current, logic 0 ²	ILOW	Sleep Mode		0		μA
Digital input current, logic 1 ²	IHIGH	Sleep Mode		33		μA

¹ Performance is guaranteed only under the conditions listed in this table.

² Not production tested.

Table 5. SKY66115-11 Electrical Specifications: Transmit Characteristics¹
(VCC = VDD = 3.3 V, TA= +25 °C, POUT = +20 dBm, 470 to 510 MHz, Characteristic Impedance [Zo] = 50 Ω, Unless Otherwise Noted)

Parameter	Symbol	Test Condition	Min	Typ	Max	Units
Input power	PIN_20dBm			4		dBm
TX small signal gain	IS21I	PIN = -25 dBm		18		dB
Input return loss	IS11I			8		dB
Output return loss	IS22I			10		dB
ANT to Rx isolation	ISO_ANT_TO_RX			35		dB
2 nd to 10 th harmonics ²	2fo to 10fo	POUT = +20 dBm: < 1 GHz > 1 GHz			-36 -30	dBm dBm
Rx to Tx transition time ³	tSWITCH	50% VCTX to 90% RF		0.6		μs
Tx Power on time ³	ton	50% VCSD to 90% RF		0.1		μs
Tx Power off time ³	toff	50% VCSD to 10% RF		0.1		μs
Non-harmonic spurious ³	PSPUR	VSWR 6:1, all phases			-42	dBm

¹ Performance is guaranteed only under the conditions listed in this table.

² 2nd to 5th harmonics are production tested. 6th to 10th harmonics are characterized only.

³ Not production tested.

Table 6. SKY66115-11 Electrical Specifications: Receive Characteristics¹
(V_{CC} = V_{DD} = 3.3 V, T_A = +25 °C, P_{IN} = 0 dBm, 470 to 510 MHz, Characteristic Impedance [Z₀] = 50 Ω, Unless Otherwise Noted)

Parameter	Symbol	Test Condition	Min	Typ	Max	Units
Insertion loss	S21			0.7		dB
Input return loss	S11			18		dB
Output return loss	S22			18		dB
Tx to Rx transition time ²	t _{SWITCH}	50% V _{CTX} to 90% RF		0.6		μs

¹ Performance is guaranteed only under the conditions listed in this table.

² Not production tested.

Table 7. SKY66115-11 Electrical Specifications: Control Voltages

Parameter	Symbol	Min	Typ	Max	Units
Control voltage: ¹					
Low	V _{LOW}	0		0.45	V
High	V _{HIGH}	2.8		V _{DD}	V

¹ V_{HIGH} should always be lower than or equal to V_{DD}.

Table 8. SKY66115-11 Mode Logic Truth Table

Mode	V _{CSD}	V _{CTX}
Sleep mode ¹	0	X
Receive (Rx) mode	X	0
Transmit (Tx) mode	1	1

¹ In the high state, CTX and CSD have an input current of 33 μA. The high state is not recommended for CTX when the device is in sleep mode.

Typical Performance Characteristics (Note 1)

(V_{CC} = 3.3 V, T_A = +25 °C, f = 470 to 510 MHz, All Unused Ports Terminated at 50 Ω, Unless Otherwise Noted)

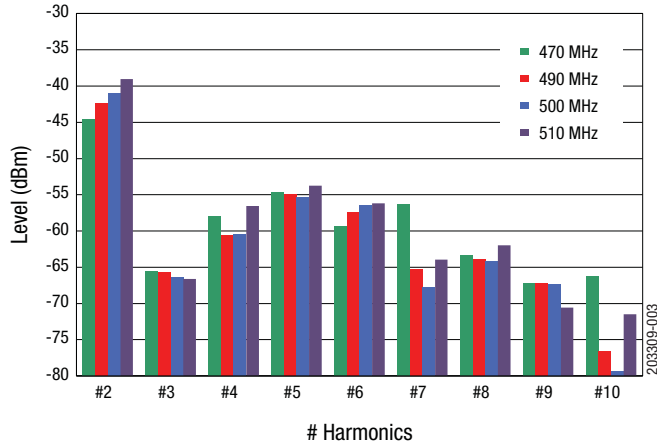

Figure 3. Typical Harmonics Level at +20 dBm Pout

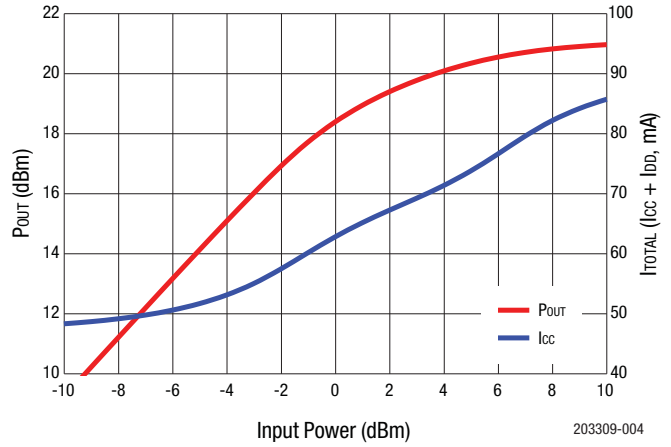

Figure 4. Typical Pout and Itotal Transfer Characteristics

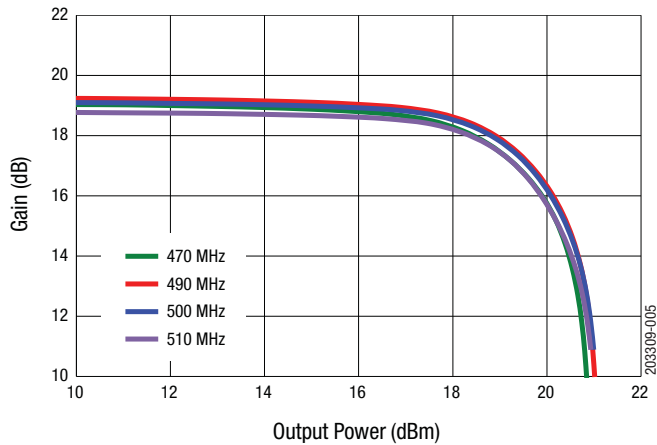

Figure 5. Typical Gain vs Pout (V_{CC} = 3.3 V)

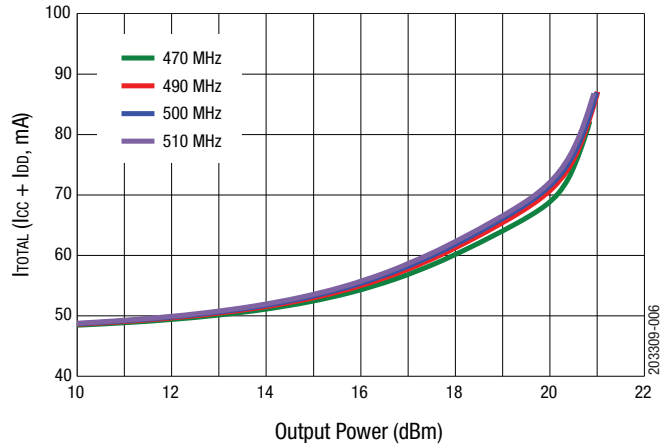

Figure 6. Typical Itotal vs Pout (V_{CC} = 3.3 V)

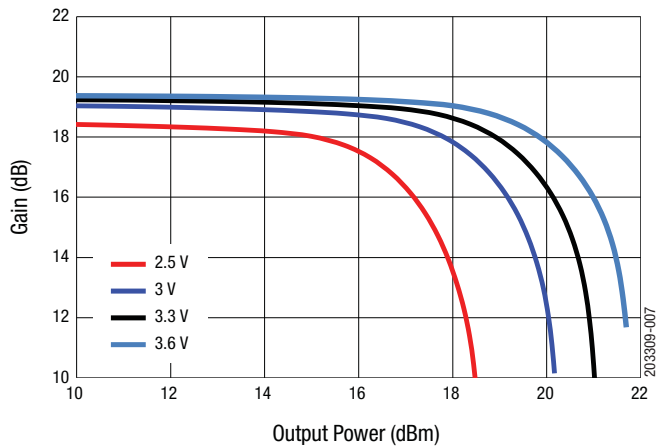

Figure 7. Typical Gain vs Pout (V_{CC} = 2.5 to 3.6 V)

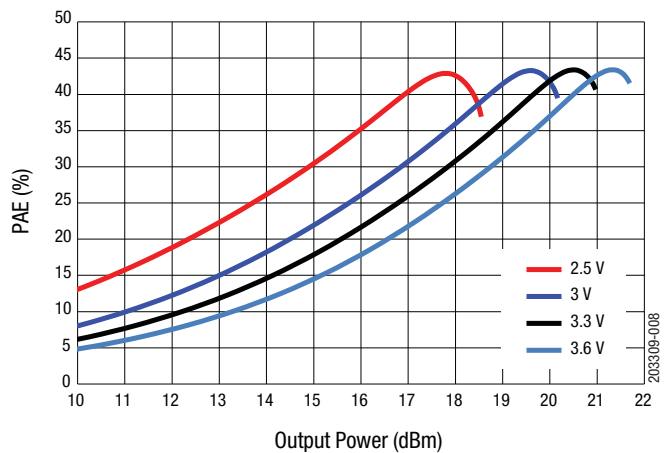

Figure 8. Typical PAE vs Pout, CW (V_{CC} = 2.5 to 3.6 V)

Evaluation Board Description

The SKY66115-11 Evaluation Board is used to test the performance of the SKY66115-11 front-end module. An Evaluation Board schematic diagram is provided in Figure 9. An optional low-pass filter (LPF) can be incorporated on the ANT port to provide additional rejection of PA output harmonic levels and/or limit unwanted signals from entering the receive path. Table 9 identifies variations in components used for different EK# boards at their respective frequencies. The board layer detail is provided in Figure 10.

PCB Recommendations:

- Metal Layer 1 = RF traces + control lines. Core thickness between top RF layer and ground plane is critical.
- Metal Layer 2 = Solid ground plane. No traces routing.
- Metal Layer 3 and 4 = Control lines + VCC traces (no VCC plane).
- Pour copper on each layer connected to the ground plane. Use VCC traces in a star distribution pattern.
- Always use four layers.

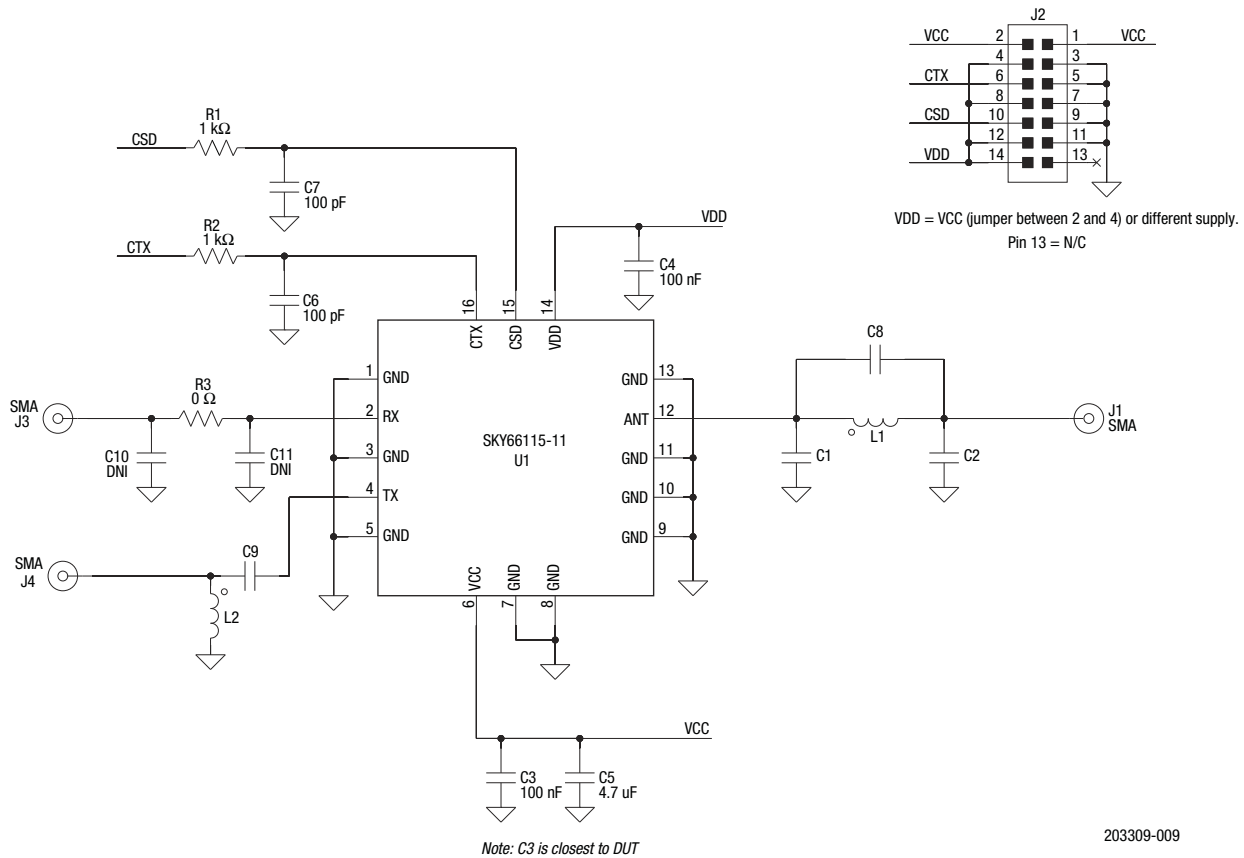
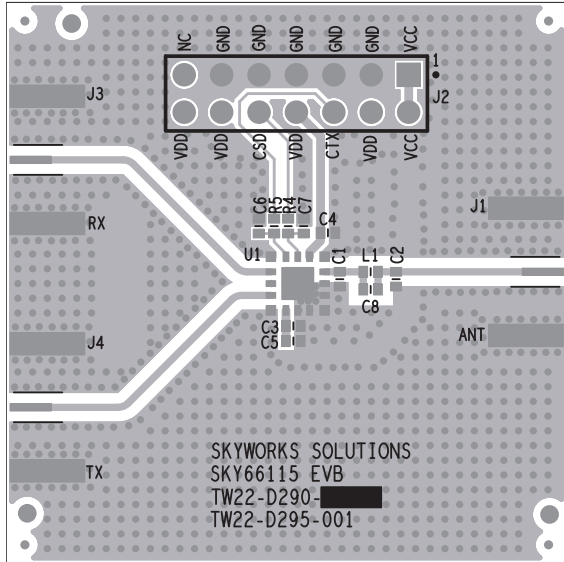

Figure 9. SKY66115-11 Evaluation Board Schematic

Table 9. Components Used by Frequency Band and Corresponding EK Board

Frequency MHz	C8	L1	C1	C2	L2	C9	EK#
470 to 510	DNI	0 Ω	DNI	DNI	DNI	0 Ω	EK1
420 to 440	3.9 pF	9.1 nH	2.7 pF	3.9 pF	15 nH	6.8 pF	EK4
400 to 420	3.9 pF	10 nH	4.0 pF	6.0 pF	15 nH	8.0 pF	EK5



Layer 1: Top – Metal

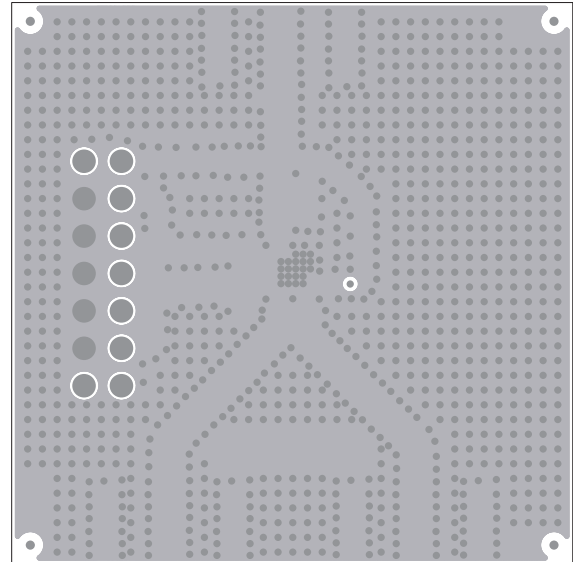

Layer 2: Ground

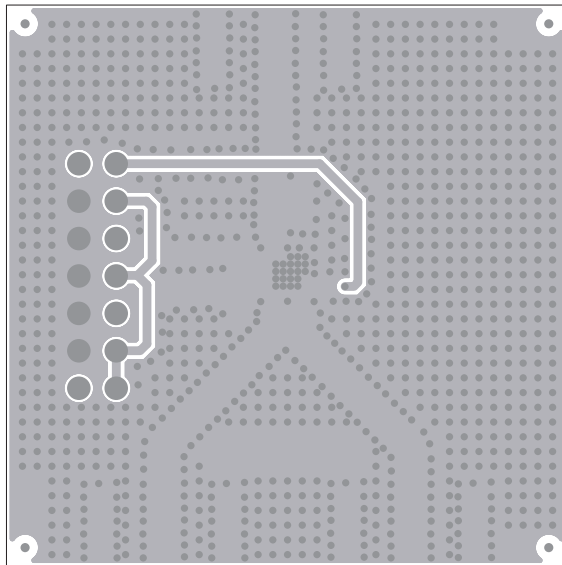

Layer 3: Ground + VCC

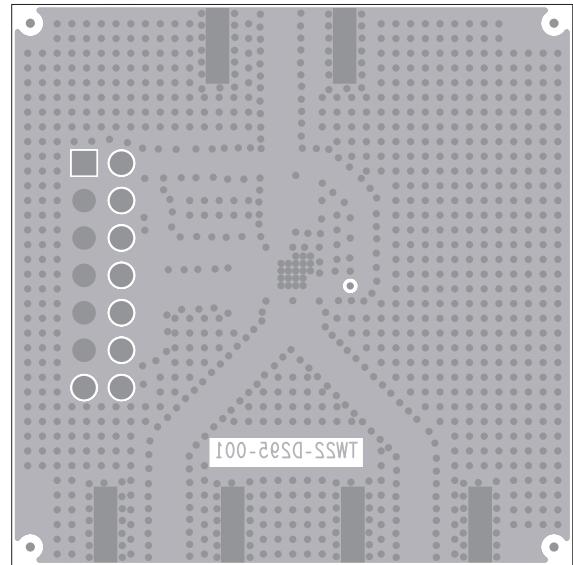

Layer 4: Solid Ground Plane

203309D-010

Figure 10. SKY66115-11 Evaluation Board Layer Detail Diagram

Package Dimensions

The SKY66115-11 typical part marking is shown in Figure 11. The PCB layout footprint for the SKY66115-11 is shown in Figure 12. Package dimensions are shown in Figure 13, and tape and reel dimensions are provided in Figure 14.

Package and Handling Information

Since the device package is sensitive to moisture absorption, it is baked and vacuum packed before shipping. Instructions on the shipping container label regarding exposure to moisture after the container seal is broken must be followed. Otherwise, problems related to moisture absorption may occur when the part is subjected to high temperature during solder assembly.

The SKY66115-11 is rated to Moisture Sensitivity Level 3 (MSL3) at 250 °C. It can be used for lead or lead-free soldering. For additional information, refer to Skyworks Application Note, *PCB Design and SMT Assembly/Rework Guidelines for MCM-L Packages*, document number 101752.

Care must be taken when attaching this product, whether it is done manually or in a production solder reflow environment. Production quantities of this product are shipped in a standard tape and reel format.

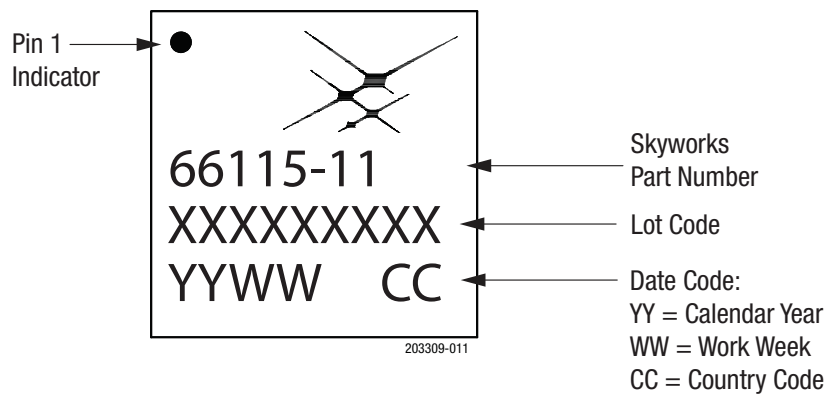
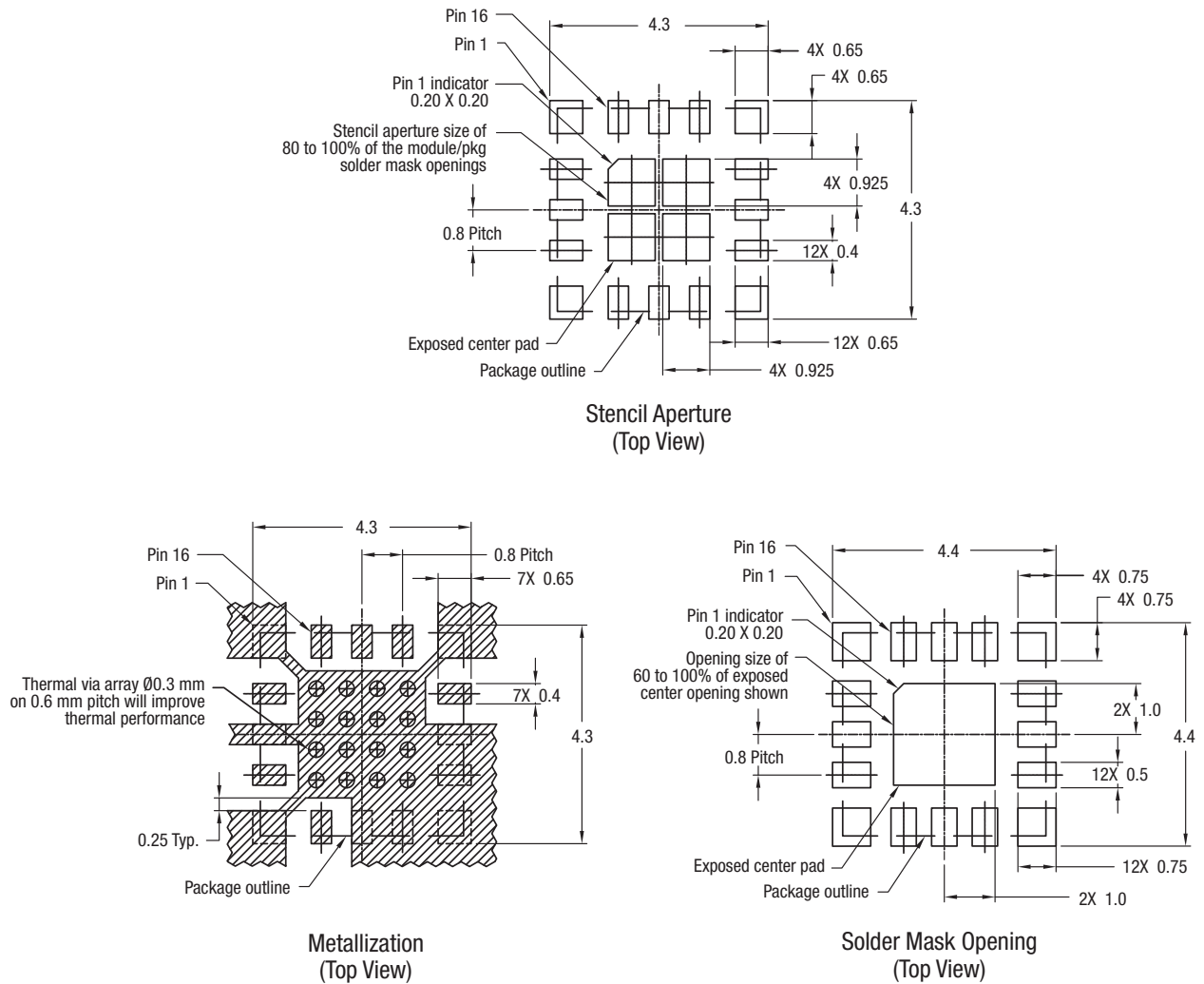

Figure 11. SKY66115-11 Typical Part Marking

DATA SHEET • SKY66115-11: 400 TO 510 MHz FRONT-END MODULE FOR RANGE EXTENSION APPLICATIONS



Notes:

1. All measurements are in millimeters.
2. Thermal vias should be resin filled and capped in accordance with IPC-4761 type VII vias. Recommended Cu thickness is 30 to 35 μm .

203309-012

Figure 12. SKY66115-11 PCB Layout Footprint

DATA SHEET • SKY66115-11: 400 TO 510 MHz FRONT-END MODULE FOR RANGE EXTENSION APPLICATIONS

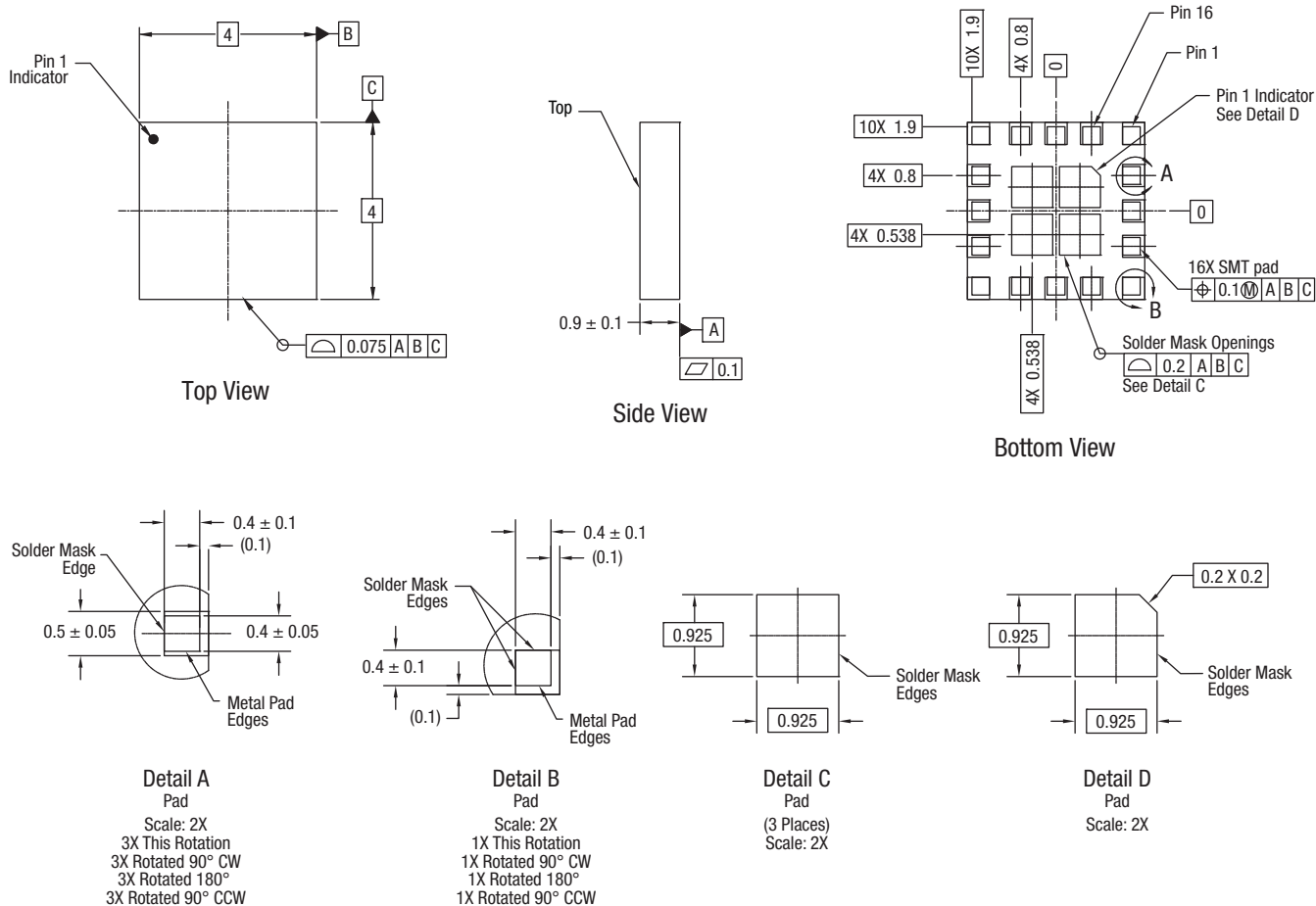

Notes:

1. Dimensions and tolerances according to ASME Y14.5M-1994.
2. All measurements are in millimeters.

203309D-013

Figure 13. SKY66115-11 Package Dimensions

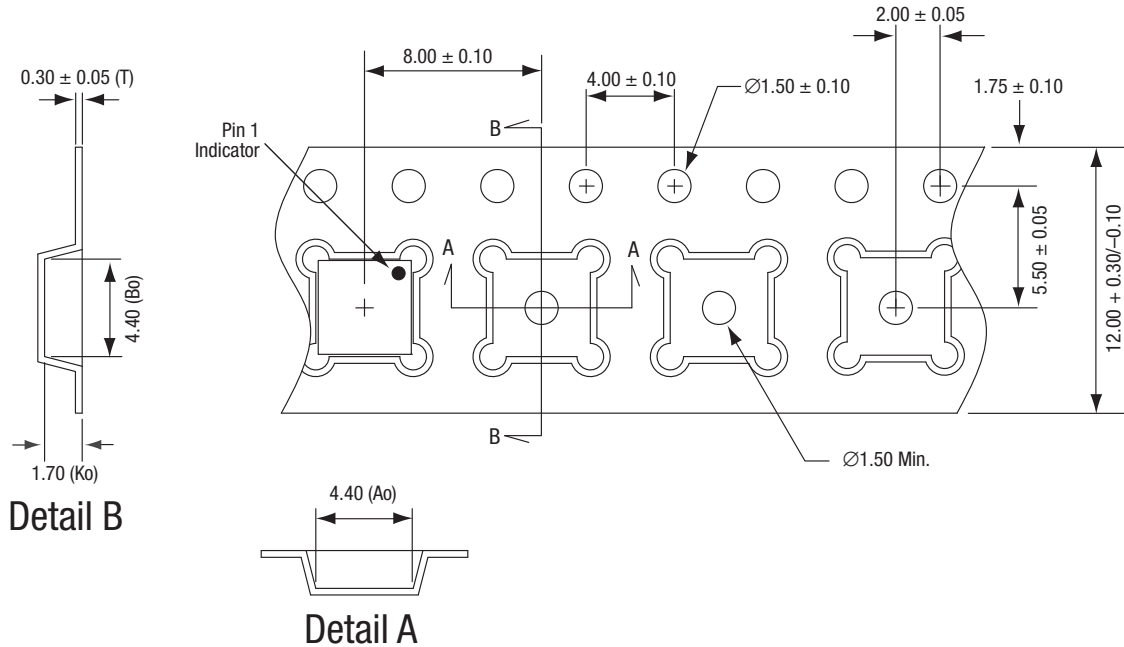

Notes:

1. Carrier tape material: black conductive polycarbonate or polystyrene.
2. Cover tape material: transparent conductive PSA.
3. Cover tape size: 9.3 mm width.
4. Ten sprocket hole pitch cumulative tolerance: ± 0.20 mm.
5. Ao and Bo measured on plane 0.30 mm above the bottom of the pocket.
6. Typical ESD surface resistivity is $\leq 1 \times 10^{10}$ Ohms/square per EIA, JEDEC tape and reel specification.
7. All measurements are in millimeters

203309-014

Figure 14. SKY66115-11 Tape and Reel Dimensions