

# SLC1 Series Label Sensor



## Datasheet



- No user adjustments – Adaptive Digital Logic (ADL™) provides revolutionary self-learning capability.
- Continuous automatic internal adjustment of sensing threshold and drift compensation.
- Registration accuracy of  $\pm 0.3$  mm (0.012") typical at web speeds up to 1.5 m/s (5 ft/s)
- Reliably detects the presence of most types of labels on web backing
  - Clear labels on an opaque backing
  - Clear labels on a clear backing
  - Opaque labels on an opaque backing
  - Opaque labels on a clear backing
- Perfect for label-registering applications, and also for label-counting tasks in slitting or rewinding applications.
- Heavy-duty metal housing, 1 mm (0.04") slot

Model Number	Supply Voltage	Cable	Output Type	User Adjustments
SLC1BB6	10 to 30 V DC	5-wire 2 m (6.5 ft)	Bipolar (NPN and PNP)	None Required
SLC1BB6Q		5-pin M12 QD		

To order the 9 m (30 ft) cable models, add the suffix "W/30" to the model number of the cabled version (e.g., **SLC1BB6 W/30**). A model with a quick disconnect (QD) connector requires an accessory mating cable.



### WARNING:

- **Do not use this device for personnel protection**
- Using this device for personnel protection could result in serious injury or death.
- This device does not include the self-checking redundant circuitry necessary to allow its use in personnel safety applications. A device failure or malfunction can cause either an energized (on) or de-energized (off) output condition.

## Overview

The SLC1 Series Label Sensor was developed to provide trouble-free detection of labels on web backing material. It reliably senses the difference between materials of extremely low visual contrast, including clear labels on clear or opaque backing. The SLC1 uses Banner's exclusive Adaptive Digital Logic (ADL™) to automatically make all sensor settings; no user adjustments are necessary.



**Note:** Labels with metallic inks, foil embossing or metal substrates are not recommended for use with SLC1 Series sensors.

Figure 1. SLC1 Label Sensor Features



1. Green power LED
2. Amber output LED
3. 1 mm (0.04 inch) slot
4. Web alignment guides

## Installing the SLC1 Series Label Sensor

Mount directly and securely to a firm surface using M4 (#8) hardware (bolts not included). See dimensions for mounting hole locations. To lessen the effects of web flutter, position the bottom fork of the sensor slightly above the web's path so that the web can glide over the bottom fork with slight tension.

For the most reliable operation, take steps to eliminate static electricity near the SLC1 Label Sensor.



Figure 2. Allowing the web to glide over the bottom fork with slight tension lessens the effects of web flutter.



## Operating the SLC1 Series Label Sensor

The SLC1 Series is self-teaching and needs no programming; there are no adjustments to set. Simply align the label web in the slot, between the guides, and allow the labels to run through the sensor. After the passing of four successive labels or 250 milliseconds (whichever is greater), the SLC1 learns the characteristics of the labels and adjusts for the proper sensing threshold and drift compensation.

For best self-programming results, turn power to the sensor ON or perform a reset after the web has been positioned in the slot. Align the labels within the web alignment guides on the side of the sensor slot as completely as possible.

For best repeatability, position the label to cover the entire sensing area (between the sensor's web alignment guides, see [Figure 2](#) on page 2). Some label configurations are sensed with greater repeatability than others; the sensor performs best when there is an abrupt change between labels. For example, labels with sharply defined edges that are perpendicular to the web direction and have larger gaps between labels are sensed most easily. Tiny gaps between labels and labels whose shape tapers at the leading and trailing edges are more difficult to sense.

Figure 3. SLC1 Label Sensor preferred sensing configurations

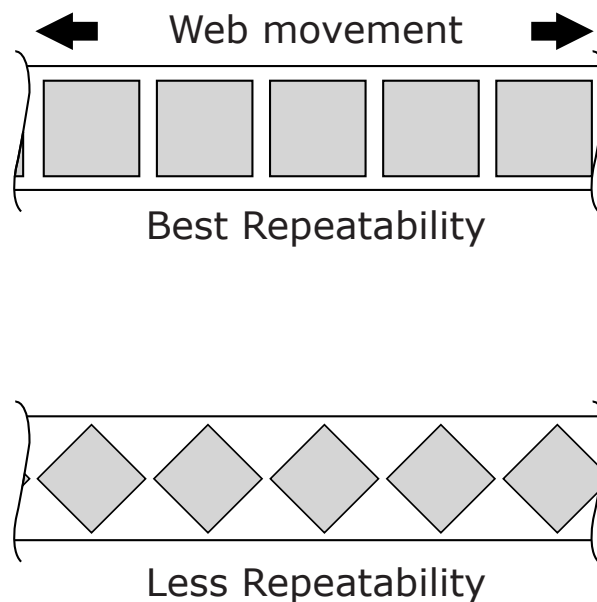

If sensing a label with a shape like that shown in [Figure 4](#) on page 3, the best repeatability results if the most perpendicular edge of the label is aligned fully within the sensing area.

Perform a reset at startup, when changing label types, or in response to an internal error indication.

To reset, turn the SLC1's power ON or cycle the power OFF for 1 second or longer and then ON again.

The SLC1 may also be reset using the sensor's gray wire. To do so, toggle the gray wire to the opposite polarity for >100 ms. Again, the sensor automatically adjusts to the current sensing conditions after the passing of four labels or 250 ms, whichever is greater.

Figure 4. For best repeatability, align the labels' flat sides between the sensor's web alignment guides

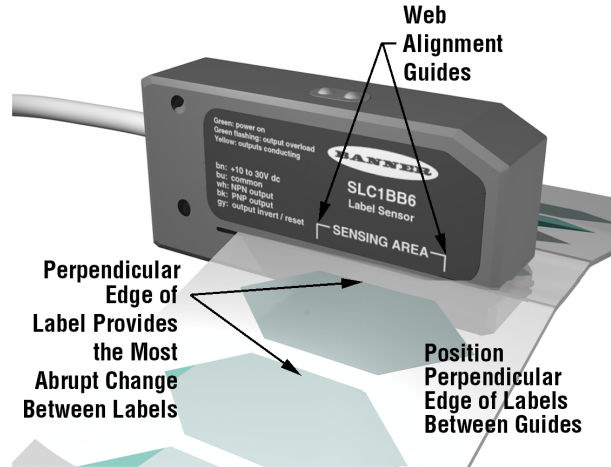

### LED Behavior

The SLC1 Series sensor has one green LED and one amber LED:

Green LED	Amber LED	Description
Solid		Power to sensor is ON
Flashing at 4 Hz		Output is overloaded
	Solid	NPN and PNP outputs are ON
Flashing alternatively at 1 Hz		Internal error; reset sensor. Internal errors are caused by several factors: <ul style="list-style-type: none"> <li>Moisture in the sensing slot</li> <li>Extreme and prolonged web flutter</li> <li>Label jams (labels touching both the top and the bottom sensor forks)</li> </ul> If an internal error occurs, correct its cause and perform a reset (cycle the sensor power OFF for at least 1 second and ON again or toggle the gray wire to the opposite polarity for >100 milliseconds).

### Maintenance

The SLC1 Series sensor may be disassembled for periodic cleaning, as needed. Use a 7/64" hex key to remove the four screws at the bottom and remove the bottom fork for cleaning. Clean the fork surfaces with a mild solvent, such as isopropyl alcohol, taking care to avoid the clear indicator light window.

### Repairs

Contact Banner Engineering for troubleshooting of this device. **Do not attempt any repairs to this Banner device; it contains no field-replaceable parts or components.** If the device, device part, or device component is determined to be defective by a Banner Applications Engineer, they will advise you of Banner's RMA (Return Merchandise Authorization) procedure.



**Important:** If instructed to return the device, pack it with care. Damage that occurs in return shipping is not covered by warranty.

## Wiring Diagrams

Figure 5. Outputs ON during gap (Turn OFF at leading edge of label)

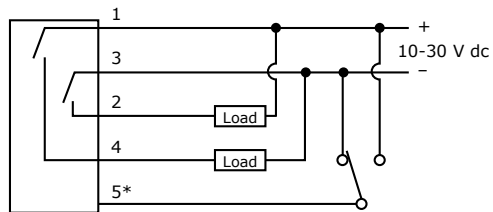
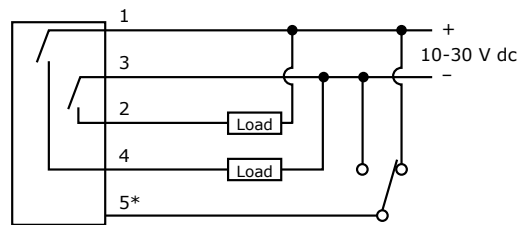

Figure 6. Outputs ON during label (Turn ON at leading edge of label)



1 - brown  
2 - white  
3 - blue  
4 - black  
5 - gray

\*Toggle to opposite polarity for > 100 milliseconds to reset microprocessor.

## Specifications

### Supply Voltage and Current

10 to 30 V DC (10% maximum ripple) at less than 60 mA (exclusive of load)

### Supply Protection Circuitry

Protected against reverse polarity and transient voltages

### Power-Up or Reset Delay

1 second typical (outputs are non-conducting during this time)

### Output Configuration

Bipolar: one current-sourcing (PNP) and one current-sinking (NPN) open-collector transistor

### Output Rating

150 mA maximum (each output)  
OFF-state leakage current: < 5 microamps at 30 V DC  
Output saturation voltage: < 1 V at 10 milliamps DC; < 1.6 V at 150 milliamps DC

### Output Protection

Protected against continuous overload and short-circuit of outputs  
Overload trip point: > 200 milliamps, typical, at 20 °C

### Output Invert Control/Reset

Gray wire has dual functionality, and may be controlled by a PLC  
Input impedance: 10 KΩ  
Outputs ON during gap (turn OFF at leading edge of label): leave open, or connect to 0 to +1 V dc  
Outputs ON during label (turn ON at leading edge of label): connect to +5 to 30 V DC  
Microprocessor reset: toggle gray wire to opposite polarity for > 100 milliseconds

### Environmental Rating

IP67, NEMA 6

### Operating Conditions

Temperature: 5 °C to 50 °C (41 °F to 122 °F)  
Maximum relative humidity: 90% at 50 °C, non-condensing

### Registration Accuracy

±0.3 mm (0.012 inch) typical, at web speeds up to 1.5 m per second (5 ft per second)

Based on 3.2 mm (0.125 inch) gap between labels. Instantaneous web speed, not average web speed, must be used to determine actual operating speeds in stepped-advance label systems.

### Speed

Maximum Counting Speed: Web speed of 10 m per second (33 ft per second)

Minimum Sensing Speed: Web speed of 100 mm per minute (4 inches per minute)

Response Time: 100 μs

Maximum Switching Speed: 1 kHz

Based on 3.2 mm (0.125 inch) gap between labels. Instantaneous web speed, not average web speed, must be used to determine actual operating speeds in stepped-advance label systems.

### Minimum Gap or Label Size

2 mm (0.08 inch)

### Adjustments

No user adjustments; automatic continuous adjustment of sensing threshold and drift compensation under internal microprocessor control  
Adjustment interval: every 250 milliseconds or 4 labels, whichever is greater

### Indicators

Two LEDs, green and amber

Green ON: power to sensor is ON

Green flashing at 4 Hz: output is overloaded

Amber ON: NPN and PNP outputs are ON

Green and amber flashing alternately at 1 Hz: internal error; reset sensor

### Construction

Housings are machined aluminum with black anodized finish

### Connections

2 m (6.5 ft) or 9 m (30 inches) 5-wire attached cable, or 5-pin Euro-style quick-disconnect fitting

Cables for QD models are purchased separately

### Certifications



Approval expected: UL

## Dimensions

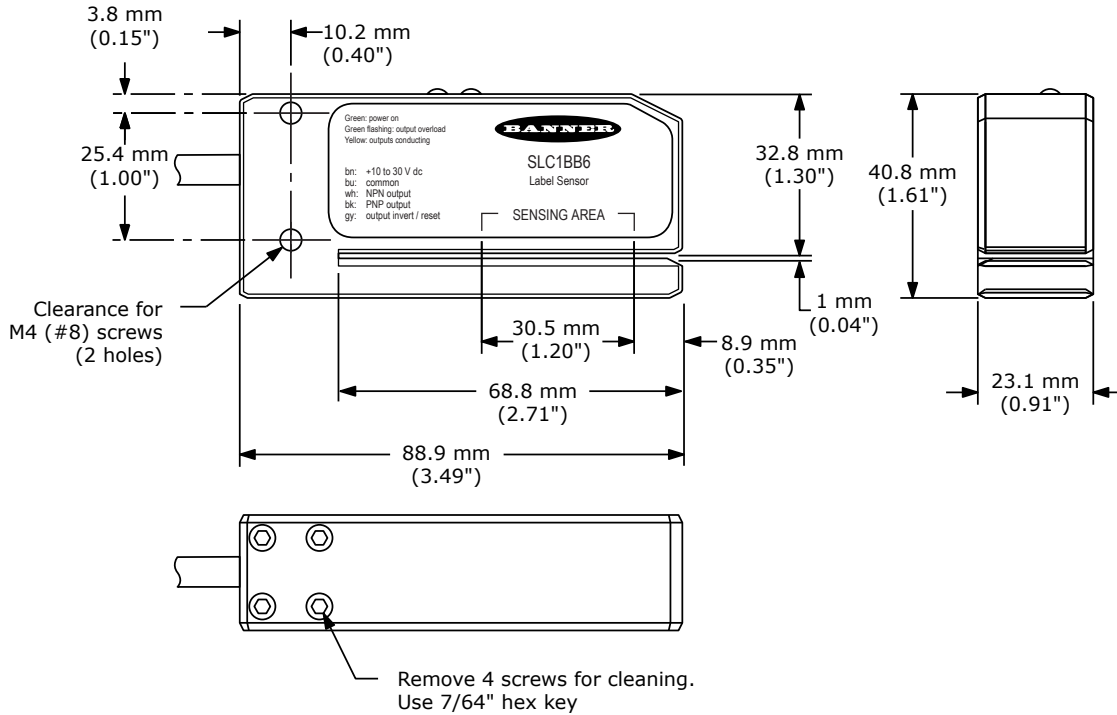

## Accessories

All measurements are listed in millimeters [inches], unless noted otherwise.

5-Pin Threaded M12 Cordsets—Single Ended				
Model	Length	Style	Dimensions	Pinout (Female)
MQDC1-501.5	0.5 m (1.5 ft)	Straight		
MQDC1-503	0.9 m (2.9 ft)			
MQDC1-506	2 m (6.5 ft)			
MQDC1-515	5 m (16.4 ft)			
MQDC1-530	9 m (29.5 ft)			
MQDC1-560	18 m (59 ft)			
MQDC1-506RA	2 m (6.5 ft)	Right-Angle		<p>1 = Brown 2 = White 3 = Blue 4 = Black 5 = Gray</p>
MQDC1-515RA	5 m (16.4 ft)			
MQDC1-530RA	9 m (29.5 ft)			
MQDC1-560RA	19 m (62.3 ft)			

## Banner Engineering Corp Limited Warranty

Banner Engineering Corp. warrants its products to be free from defects in material and workmanship for one year following the date of shipment. Banner Engineering Corp. will repair or replace, free of charge, any product of its manufacture which, at the time it is returned to the factory, is found to have been defective during the warranty period. This warranty does not cover damage or liability for misuse, abuse, or the improper application or installation of the Banner product.

**THIS LIMITED WARRANTY IS EXCLUSIVE AND IN LIEU OF ALL OTHER WARRANTIES WHETHER EXPRESS OR IMPLIED (INCLUDING, WITHOUT LIMITATION, ANY WARRANTY OF MERCHANTABILITY OR FITNESS FOR A PARTICULAR PURPOSE), AND WHETHER ARISING UNDER COURSE OF PERFORMANCE, COURSE OF DEALING OR TRADE USAGE.**