

SLE3 Slot Sensor



Datasheet

Slot sensor for adhesive labels



- Optimized to sense adhesive labels adhered to a roll of backing paper
- High intensity infrared LED reduces sensitivity to web flutter
- A response time of 35 microseconds allows the SLE3 sensor to keep up with even the fastest high speed rewinders
- 10 mm width allows installation in small spaces
- Quick setup with the one-press **(Set)(+)** button
- Oversize indicator allows you to know the sensor's performance, even from a few feet away



WARNING:

- **Do not use this device for personnel protection**
- Using this device for personnel protection could result in serious injury or death.
- This device does not include the self-checking redundant circuitry necessary to allow its use in personnel safety applications. A device failure or malfunction can cause either an energized (on) or de-energized (off) output condition.

Models

Models	Supply Voltage	Output	Connections
SLE3-PIR-Q7	4.75 V DC to 30 V DC	PNP	Integral 4-pin M8 male quick-disconnect connector
SLE3-PIR-2M			1.8 m (6 ft) unterminated 4-wire cable
SLE3-NIR-Q7		NPN	Integral 4-pin M8 male quick-disconnect connector
SLE3-NIR-2M			1.8 m (6 ft) unterminated 4-wire cable

Features and Indicators

Figure 1. Features

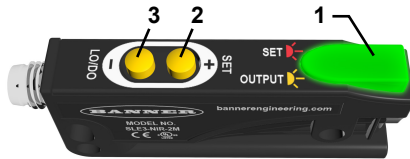

1. Three-color output indicator
2. (SET)(+) button
3. (LO/DO)(-) button

Output Indicator

- Green LED indicates power ON and output OFF
- Amber LED indicates output ON
- Red LED indicates SET process

Figure 2. Optical Path Alignment Marks

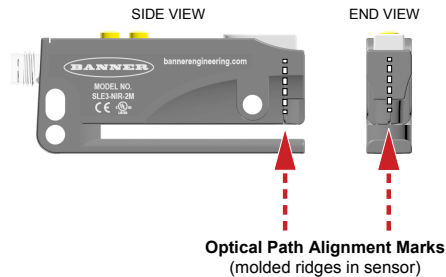

(SET)(+) Button

- Press and hold for 1seconds for TEACH
- Tap to adjust the threshold (+)

(LO/DO)(-) Button

- Press and hold to toggle between light operate and dark operate
- Tap to adjust the threshold (-)



Installation Instructions

The SLE3 sensor was designed for standard mounting using the clearance holes.

Wiring

Figure 3. NPN

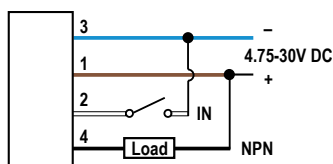

Figure 4. PNP

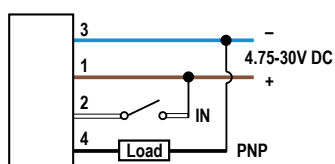
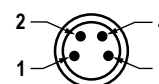

Figure 5. M8 Male



1 = Brown
2 = White
3 = Blue
4 = Black

Configuring the Sensor

Use the following steps to configure the sensor.

1. Power on the sensor.
The indicator illuminates green.
2. Place the gap between labels in the sensor's view using the optical path alignment guides. See [Figure 2](#) on page 1.



Tip: If the gap is difficult to work with, try removing a label.

3. With the gap in view, press and hold **(SET)(+)** or activate the remote input wire for > 1 second, then release the button or deactivate the remote input wire.
The indicator turns red, then back to green or amber. The indicator flashes red/green when the signal is insufficient.
4. If necessary, use the **(SET)(+)** and **(LO/DO)(-)** buttons to adjust the threshold.
5. Press and hold **(LO/DO)(-)** to toggle between light operate (LO) and dark operate (DO).
The sensor configuration is complete.

Specifications

Supply Voltage and Current

4.75 V DC to 30 V DC
Protected against reverse polarity
18 milliamps (exclusive of load)

Output

NPN or PNP (depending on model)
Outputs sink or source up to 120 milliamps (current limit)
Protected against output short-circuit

Remote SET Input

Active high (PNP) or active low (NPN), depending on model (1ma)
Protected against transient overvoltages

Response Time

35 μ s

Hysteresis

5%

Construction

Top lid: polycarbonate
Output window: ABS
Case: 50% glass filled nylon
Buttons: silicon rubber

Slot

3 mm

Sensing Beam

High intensity infrared LED

Light Immunity

Responds to the pulsed modulated light source of the sensor, resulting in high immunity to most ambient light

Connection

Integral 4-pin M8 male quick-disconnect connector
1.8 m (6 ft) unterminated 4-wire cable

Ambient Temperature

-40 °C to +70 °C (-40 °F to +158 °F)

Environmental Rating

IP65
RoHS Compliant



Banner Engineering Europe Park Lane, Culliganlaan 2F bus
3, 1831 Diegem, BELGIUM

Turck Banner LTD Blenheim House, Blenheim Court,
Wickford, Essex SS11 8YT, Great Britain

Dimensions

All measurements are listed in millimeters [inches], unless noted otherwise.

Quick Disconnect Models

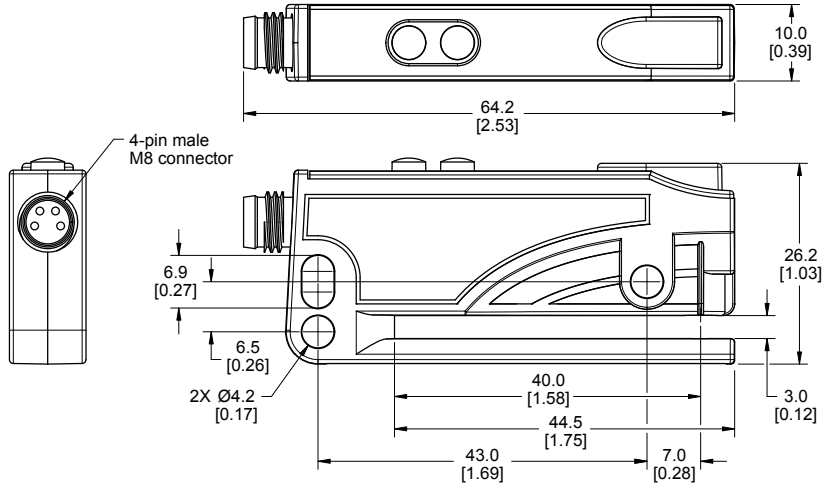

Cable Models

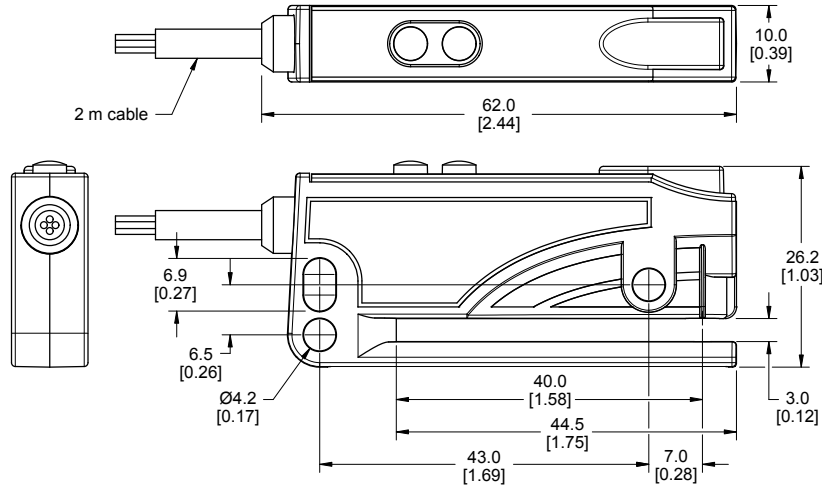

Accessories

Cordsets

4-Pin Threaded M8 Cordsets—Single Ended				
Model	Length	Style	Dimensions	Pinout (Female)
PKG4M-2	2.04 m (6.68 ft)	Straight		
PKG4M-5	5 m (16.4 ft)			
PKG4M-9	9.04 m (29.6 ft)			
PKW4M-2	2 m (6.56 ft)	Right Angle		
PKW4M-5	5 m (16.4 ft)			
PKW4M-9	9 m (29.5 ft)			

1 = Brown
2 = White
3 = Blue
4 = Black