



Features

- Logic & Mixed Signal Circuits
- Highly Versatile Macrocells
- Read Back Protection (Read Lock)
- 1.8 V (±5%) to 5 V (±10%) Supply
- Operating Temperature Range: -40°C to 85°C
- RoHS Compliant / Halogen-Free
- 14-pin STQFN: 2 x 2.2 x 0.55 mm, 0.4 mm pitch

Applications

- Personal Computers and Servers
- PC Peripherals
- Consumer Electronics
- Data Communications Equipment
- Handheld and Portable Electronics

Pin Configuration

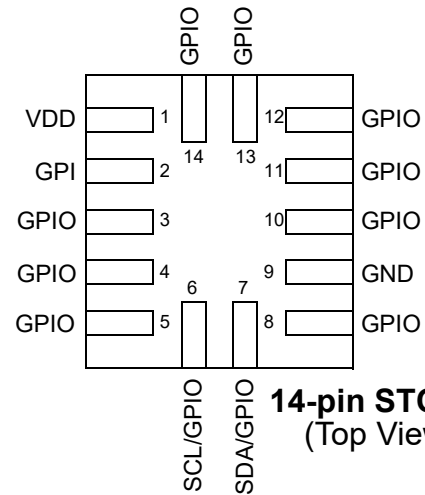

Block Diagram

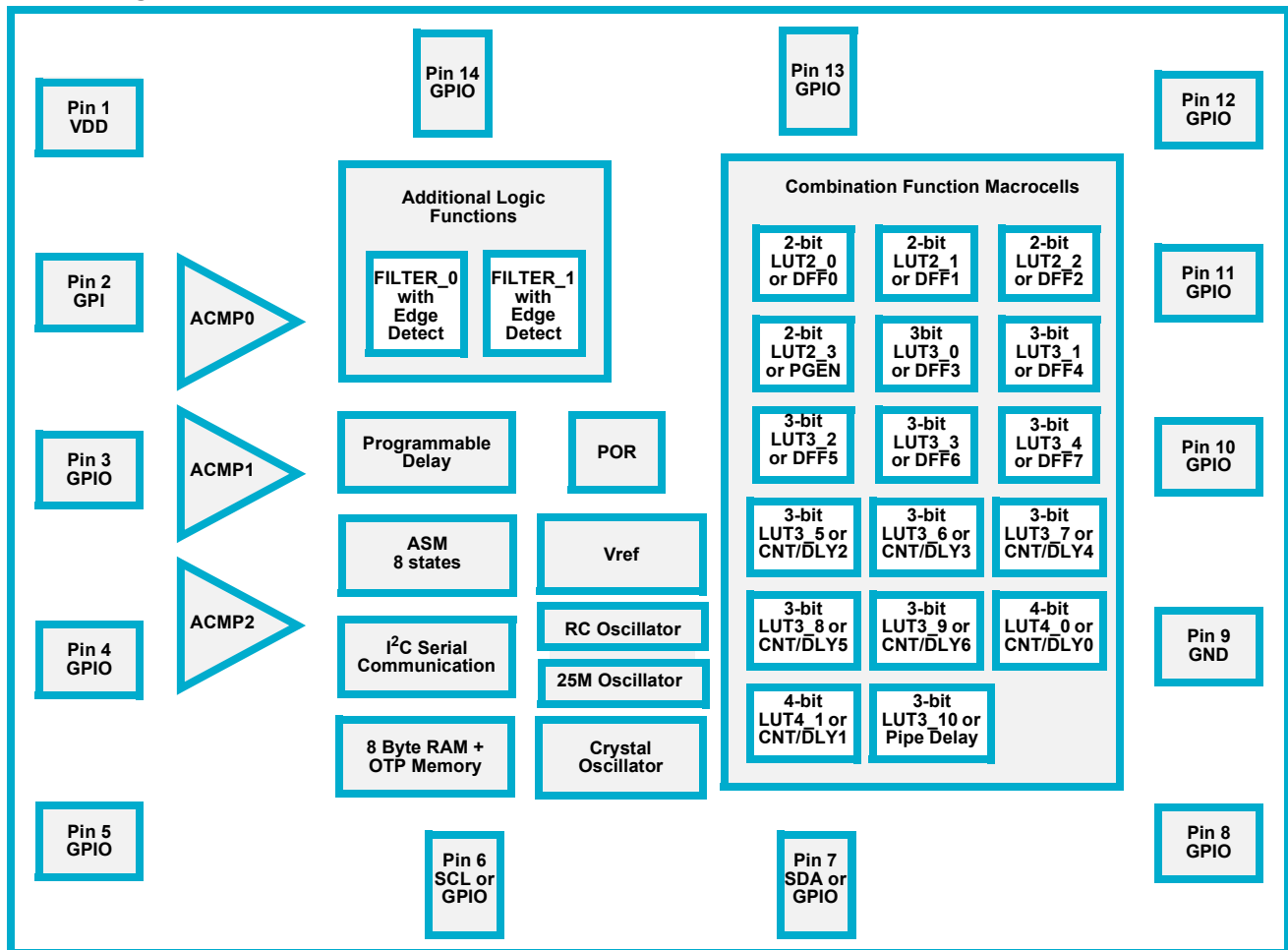

1.0 Overview

The SLG46534 provides a small, low power component for commonly used mixed-signal functions. The user creates their circuit design by programming the one time Non-Volatile Memory (NVM) to configure the interconnect logic, the IO Pins and the macrocells of the SLG46534. This highly versatile device allows a wide variety of mixed-signal functions to be designed within a very small, low power single integrated circuit. The macrocells in the device include the following:

- Three Analog Comparators (ACMP)
- Nineteen Combination Function Macrocells
 - Three Selectable DFF/Latch or 2-bit LUTs
 - One Selectable Continuous DFF/Latch or 3-bit LUT
 - Four Selectable DFF/Latch or 3-bit LUTs
 - One Selectable Pipe Delay or 3-bit LUT
 - One Selectable Programmable Pattern Generator or 2-bit LUT
 - Five 8-bit delays/counters or 3-bit LUTs
 - Two 16-bit delays/counters or 4-bit LUTs
 - Two Deglitch Filters with Edge Detectors
- Asynchronous State Machine
 - Eight States
 - Flexible input logic from state transitions
- Serial Communications
 - I²C Protocol compliant
- Pipe Delay – 16 stage/3 output (Part of Combination Function Macrocell)
- Programmable Delay
- Two Oscillators (OSC)
 - Configurable 25 kHz/2 MHz
 - 25 MHz RC Oscillator
- Crystal Oscillator
- Power-On-Reset (POR)
- Eight Byte RAM + OTP User Memory
 - RAM Memory space that is readable and writable via I²C
 - User defined initial values transferred from OTP

2.0 Pin Description

2.1 Functional Pin Description

| Pin # | Pin Name | Function |
|-------|----------|---|
| 1 | VDD | Power Supply |
| 2 | GPI | General Purpose Input |
| 3 | GPIO | General Purpose IO |
| 4 | GPIO | General Purpose IO or ACMP0 (+) |
| 5 | GPIO | General Purpose IO with OE or External Vref (ACMP0 IN-) |
| 6 | SCL/GPIO | General Purpose IO SCL or GPIOD (NMOS open drain only) |
| 7 | SDA/GPIO | General Purpose IO SDA or GPIOD (NMOS open drain only) |
| 8 | GPIO | General Purpose IO with OE or ACMP1 (+) |
| 9 | GND | Ground |
| 10 | GPIO | General Purpose IO External Vref (ACMP1 IN-) |
| 11 | GPIO | General Purpose IO with OE |
| 12 | GPIO | General Purpose IO with OE |
| 13 | GPIO | General Purpose IO |
| 14 | GPIO | General Purpose IO or External Clock Input |

3.0 User Programmability

Non-volatile memory (NVM) is used to configure the SLG46534’s connection matrix routing and macrocells. The NVM is One-Time-Programmable (OTP). However, GreenPAK development tools can be used to configure the connection matrix and macrocells, without programming the NVM, to allow on-chip emulation. This configuration will remain active on the device as long as it remains powered and can be re-written as needed to facilitate rapid design changes.

When a design is ready for in-circuit testing, the same GreenPAK development tools can be used to program the NVM and create samples for small quantity builds. Once the NVM is programmed, the device will retain this configuration for the duration of its lifetime.

Once the design is finalized, the design file can be forwarded to Renesas Electronics Corporation to integrate into the production process.

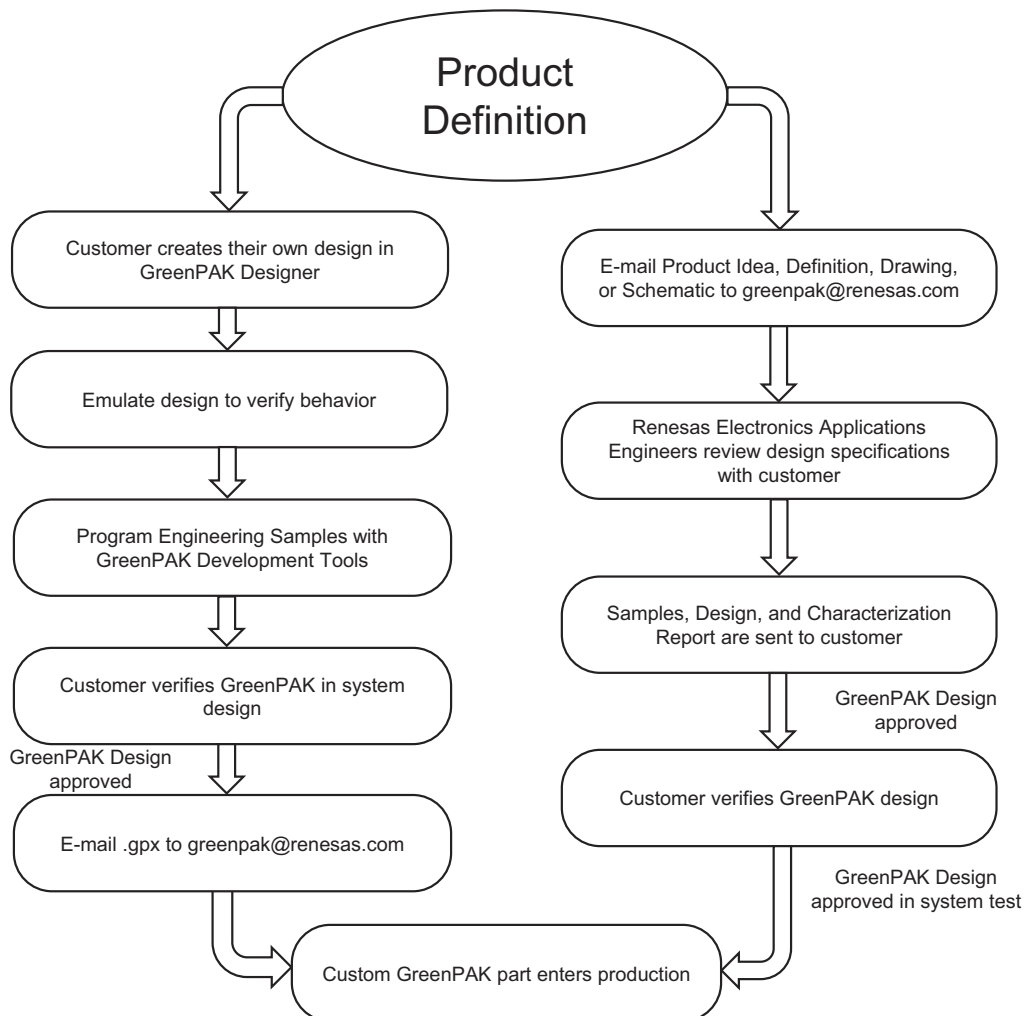

Figure 1. Steps to create a custom GreenPAK device

4.0 Ordering Information

| Part Number | Type |
|-------------|---|
| SLG46534V | 14-pin STQFN |
| SLG46534VTR | 14-pin STQFN - Tape and Reel (3k units) |

Note 1: Use SLG46534V to order. Shipments are automatically in Tape and Reel.

Note 2: "TR" suffix is no longer used. It is a legacy naming convention shown here only for informational purposes.

5.0 Electrical Specifications

5.1 Absolute Maximum Conditions

| Parameter | | Min. | Max. | Unit |
|--|--------------|-----------|----------------|------|
| Supply voltage on V_{DD} relative to GND | | -0.5 | 7 | V |
| DC Input voltage | | GND - 0.5 | $V_{DD} + 0.5$ | V |
| Maximum Average or DC Current (Through pin) | Push-Pull 1x | -- | 11 | mA |
| | Push-Pull 2x | -- | 16 | |
| | OD 1x | -- | 11 | |
| | OD 2x | -- | 21 | |
| | OD 4x | -- | 43 | |
| Current at Input Pin | | -1.0 | 1.0 | mA |
| Storage Temperature Range | | -65 | 150 | °C |
| Junction Temperature | | -- | 150 | °C |
| ESD Protection (Human Body Model) | | 2000 | -- | V |
| ESD Protection (Charged Device Model) | | 1300 | -- | V |
| Moisture Sensitivity Level | | 1 | | |

5.2 Electrical Characteristics (1.8 V $\pm 5\%$ V_{DD})

| Symbol | Parameter | Condition/Note | Min. | Typ. | Max. | Unit |
|------------|------------------------------------|--|------|------|----------|------|
| V_{DD} | Supply Voltage | | 1.71 | 1.80 | 1.89 | V |
| T_A | Operating Temperature | | -40 | 25 | 85 | °C |
| V_{PP} | Programming Voltage | | 7.25 | 7.50 | 7.75 | V |
| V_{ACMP} | ACMP Input Voltage Range | Positive Input | 0 | -- | V_{DD} | V |
| | | Negative Input | 0 | -- | 1.2 | V |
| V_{IH} | HIGH-Level Input Voltage | Logic Input | 1.06 | -- | V_{DD} | V |
| | | Logic Input with Schmitt Trigger | 1.28 | -- | V_{DD} | V |
| | | Low-Level Logic Input | 0.94 | -- | V_{DD} | V |
| V_{IL} | LOW-Level Input Voltage | Logic Input | 0 | -- | 0.76 | V |
| | | Logic Input with Schmitt Trigger | 0 | -- | 0.49 | V |
| | | Low-Level Logic Input | 0 | -- | 0.52 | V |
| V_{HYS} | Schmitt Trigger Hysteresis Voltage | Logic Input with Schmitt Trigger | 0.10 | 0.41 | 0.66 | V |
| I_{LKG} | Input leakage (Absolute Value) | | -- | 1 | 1000 | nA |
| V_{OH} | HIGH-Level Output Voltage | Push-Pull, $I_{OH} = 100 \mu A$, 1X Drive | 1.69 | 1.79 | -- | V |
| | | PMOS OD, $I_{OH} = 100 \mu A$, 1X Drive | 1.69 | 1.79 | -- | V |
| | | Push-Pull, $I_{OH} = 100 \mu A$, 2X Drive | 1.70 | 1.79 | -- | V |
| | | PMOS OD, $I_{OH} = 100 \mu A$, 2X Drive | 1.70 | 1.79 | -- | V |

| Symbol | Parameter | Condition/Note | Min. | Typ. | Max. | Unit |
|---------------------|---|--|------|-------|-----------------|------|
| V _{OL} | LOW-Level Output Voltage | Push-Pull, I _{OL} = 100 μA, 1X Drive | -- | 0.009 | 0.013 | V |
| | | Push-Pull, I _{OL} = 100 μA, 2X Drive | -- | 0.004 | 0.006 | V |
| | | Open Drain, I _{OL} = 100 μA, 1X Drive | -- | 0.006 | 0.009 | V |
| | | Open Drain, I _{OL} = 100 μA, 2X Drive | -- | 0.003 | 0.004 | V |
| | | Open Drain NMOS 4X, I _{OL} = 100 μA | -- | 0.001 | 0.002 | V |
| I _{OH} | HIGH-Level Output Pulse Current (see Note 1) | Push-Pull, V _{OH} = V _{DD} - 0.2, 1X Drive | 1.07 | 1.70 | -- | mA |
| | | PMOS OD, V _{OH} = V _{DD} - 0.2, 1X Drive | 1.07 | 1.70 | -- | mA |
| | | Push-Pull, V _{OH} = V _{DD} - 0.2, 2X Drive | 2.22 | 3.41 | -- | mA |
| | | PMOS OD, V _{OH} = V _{DD} - 0.2, 2X Drive | 2.22 | 3.41 | -- | mA |
| I _{OL} | LOW-Level Output Pulse Current (see Note 1) | Push-Pull, V _{OL} = 0.15 V, 1X Drive | 0.92 | 1.69 | -- | mA |
| | | Push-Pull, V _{OL} = 0.15 V, 2X Drive | 1.83 | 3.38 | -- | mA |
| | | Open Drain, V _{OL} = 0.15 V, 1X Drive | 1.38 | 2.53 | -- | mA |
| | | Open Drain, V _{OL} = 0.15 V, 2X Drive | 2.75 | 5.07 | -- | mA |
| | | Open Drain NMOS 4X, V _{OL} = 0.15 V | 7.21 | 9.00 | -- | mA |
| I _{VDD} | Maximum Average or DC Current Through V _{DD} Pin (Per chip side, see Note 2) | T _J = 85°C | -- | -- | 45 | mA |
| | | T _J = 110°C | -- | -- | 22 | mA |
| I _{GND} | Maximum Average or DC Current Through GND Pin (Per chip side, see Note 2) | T _J = 85°C | -- | -- | 86 | mA |
| | | T _J = 110°C | -- | -- | 41 | mA |
| V _O | Maximal Voltage Applied to any PIN in High-Impedance State | | -- | -- | V _{DD} | V |
| T _{SU} | Startup Time | From V _{DD} rising past PON _{THR} | 0.63 | 1.36 | 1.87 | ms |
| PON _{THR} | Power On Threshold | V _{DD} Level Required to Start Up the Chip | 1.41 | 1.54 | 1.66 | V |
| POFF _{THR} | Power Off Threshold | V _{DD} Level Required to Switch Off the Chip | 1.00 | 1.15 | 1.31 | V |
| R _{PUP} | Pull Up Resistance | 1 M Pull Up | -- | 1 | -- | MΩ |
| | | 100 k Pull Up | -- | 100 | -- | kΩ |
| | | 10 k Pull Up | -- | 10 | -- | kΩ |
| R _{PDWN} | Pull Down Resistance | 1 M Pull Down | -- | 1 | -- | MΩ |
| | | 100 k Pull Down | -- | 100 | -- | kΩ |
| | | 10 k Pull Down | -- | 10 | -- | kΩ |

Note 1: DC or average current through any pin should not exceed value given in Absolute Maximum Conditions.

Note 2: The GreenPAK's power rails are divided in two sides. Pins 2, 3, 4, 5, 6, 7 and 8 are connected to one side, pins 10, 11, 12, 13 and 14 to another.

5.3 Electrical Characteristics (3.3 V ±10% V_{DD})

| Symbol | Parameter | Condition/Note | Min. | Typ. | Max. | Unit |
|-------------------|---|---|-------|-------|-----------------|------|
| V _{DD} | Supply Voltage | | 3.0 | 3.3 | 3.6 | V |
| T _A | Operating Temperature | | -40 | 25 | 85 | °C |
| V _{PP} | Programming Voltage | | 7.25 | 7.50 | 7.75 | V |
| V _{ACMP} | ACMP Input Voltage Range | Positive Input | 0 | -- | V _{DD} | V |
| | | Negative Input | 0 | -- | 1.2 | V |
| V _{IH} | HIGH-Level Input Voltage | Logic Input | 1.81 | -- | V _{DD} | V |
| | | Logic Input with Schmitt Trigger | 2.14 | -- | V _{DD} | V |
| | | Low-Level Logic Input | 1.06 | -- | V _{DD} | V |
| V _{IL} | LOW-Level Input Voltage | Logic Input | 0 | -- | 1.31 | V |
| | | Logic Input with Schmitt Trigger | 0 | -- | 0.97 | V |
| | | Low-Level Logic Input | 0 | -- | 0.67 | V |
| V _{HYS} | Schmitt Trigger Hysteresis Voltage | Logic Input with Schmitt Trigger | 0.29 | 0.62 | 0.94 | V |
| I _{LGK} | Input leakage (Absolute Value) | | -- | 1 | 1000 | nA |
| V _{OH} | HIGH-Level Output Voltage | Push-Pull, I _{OH} = 3 mA, 1X Drive | 2.70 | 3.12 | -- | V |
| | | PMOS OD, I _{OH} = 3 mA, 1X Drive | 2.70 | 3.12 | -- | V |
| | | Push-Pull, I _{OH} = 3 mA, 2X Drive | 2.85 | 3.21 | -- | V |
| | | PMOS OD, I _{OH} = 3 mA, 2X Drive | 2.86 | 3.21 | -- | V |
| V _{OL} | LOW-Level Output Voltage | Push-Pull, I _{OL} = 3 mA, 1X Drive | -- | 0.13 | 0.23 | V |
| | | Push-Pull, I _{OL} = 3 mA, 2X Drive | -- | 0.06 | 0.11 | V |
| | | Open Drain, I _{OL} = 3 mA, 1X Drive | -- | 0.08 | 0.15 | V |
| | | Open Drain, I _{OL} = 3 mA, 2X Drive | -- | 0.04 | 0.08 | V |
| | | Open Drain NMOS 4X, I _{OL} = 3 mA | -- | 0.02 | 0.04 | V |
| I _{OH} | HIGH-Level Output Pulse Current (see Note 1) | Push-Pull, V _{OH} = 2.4 V, 1X Drive | 6.05 | 12.08 | -- | mA |
| | | PMOS OD, V _{OH} = 2.4 V, 1X Drive | 6.05 | 12.08 | -- | mA |
| | | Push-Pull, V _{OH} = 2.4 V, 2X Drive | 11.54 | 24.16 | -- | mA |
| | | PMOS OD, V _{OH} = 2.4 V, 2X Drive | 11.52 | 24.16 | -- | mA |
| I _{OL} | LOW-Level Output Pulse Current (see Note 1) | Push-Pull, V _{OL} = 0.4 V, 1X Drive | 4.88 | 8.24 | -- | mA |
| | | Push-Pull, V _{OL} = 0.4 V, 2X Drive | 9.75 | 16.49 | -- | mA |
| | | Open Drain, V _{OL} = 0.4 V, 1X Drive | 7.31 | 12.37 | -- | mA |
| | | Open Drain, V _{OL} = 0.4 V, 2X Drive | 14.54 | 24.74 | -- | mA |
| | | Open Drain NMOS 4X, V _{OL} = 0.4 V | 31.32 | 41.06 | -- | mA |
| I _{VDD} | Maximum Average or DC Current Through V _{DD} Pin (Per chip side, see Note 2) | T _J = 85°C | -- | -- | 45 | mA |
| | | T _J = 110°C | -- | -- | 22 | mA |
| I _{GND} | Maximum Average or DC Current Through GND Pin (Per chip side, see Note 2) | T _J = 85°C | -- | -- | 86 | mA |
| | | T _J = 110°C | -- | -- | 41 | mA |

| Symbol | Parameter | Condition/Note | Min. | Typ. | Max. | Unit |
|--------------|--|--|------|------|----------|------------|
| V_O | Maximal Voltage Applied to any PIN in High-Impedance State | | -- | -- | V_{DD} | V |
| T_{SU} | Startup Time | From V_{DD} rising past PON_{THR} | 0.61 | 1.24 | 1.65 | ms |
| PON_{THR} | Power On Threshold | V_{DD} Level Required to Start Up the Chip | 1.41 | 1.54 | 1.66 | V |
| $POFF_{THR}$ | Power Off Threshold | V_{DD} Level Required to Switch Off the Chip | 1.00 | 1.15 | 1.31 | V |
| R_{PUP} | Pull Up Resistance | 1 M Pull Up | -- | 1 | -- | M Ω |
| | | 100 k Pull Up | -- | 100 | -- | k Ω |
| | | 10 k Pull Up | -- | 10 | -- | k Ω |
| R_{PDWN} | Pull Down Resistance | 1 M Pull Down | -- | 1 | -- | M Ω |
| | | 100 k Pull Down | -- | 100 | -- | k Ω |
| | | 10 k Pull Down | -- | 10 | -- | k Ω |

Note 1: DC or average current through any pin should not exceed value given in Absolute Maximum Conditions.
 Note 2: The GreenPAK's power rails are divided in two sides. Pins 2, 3, 4, 5, 6, 7 and 8 are connected to one side, pins 10, 11, 12, 13 and 14 to another.

5.4 Electrical Characteristics (5 V ±10% V_{DD})

| Symbol | Parameter | Condition/Note | Min. | Typ. | Max. | Unit |
|-------------------|---|---|-------|-------|-----------------|------|
| V _{DD} | Supply Voltage | | 4.5 | 5.0 | 5.5 | V |
| T _A | Operating Temperature | | -40 | 25 | 85 | °C |
| V _{PP} | Programming Voltage | | 7.25 | 7.50 | 7.75 | V |
| V _{ACMP} | ACMP Input Voltage Range | Positive Input | 0 | -- | V _{DD} | V |
| | | Negative Input | 0 | -- | 1.2 | V |
| V _{IH} | HIGH-Level Input Voltage | Logic Input | 2.68 | -- | V _{DD} | V |
| | | Logic Input with Schmitt Trigger | 3.34 | -- | V _{DD} | V |
| | | Low-Level Logic Input | 1.15 | -- | V _{DD} | V |
| V _{IL} | LOW-Level Input Voltage | Logic Input | 0 | -- | 1.96 | V |
| | | Logic Input with Schmitt Trigger | 0 | -- | 1.41 | V |
| | | Low-Level Logic Input | 0 | -- | 0.77 | V |
| V _{HYS} | Schmitt Trigger Hysteresis Voltage | Logic Input with Schmitt Trigger | 0.44 | 0.90 | 1.38 | V |
| I _{LGK} | Input leakage (Absolute Value) | | -- | 1 | 1000 | nA |
| V _{OH} | HIGH-Level Output Voltage | Push-Pull, I _{OH} = 5 mA, 1X Drive | 4.15 | 4.76 | -- | V |
| | | PMOS OD, I _{OH} = 5 mA, 1X Drive | 4.16 | 4.76 | -- | V |
| | | Push-Pull, I _{OH} = 5 mA, 2X Drive | 4.32 | 4.89 | -- | V |
| | | PMOS OD, I _{OH} = 5 mA, 2X Drive | 4.33 | 4.89 | -- | V |
| V _{OL} | LOW-Level Output Voltage | Push-Pull, I _{OL} = 5 mA, 1X Drive | -- | 0.19 | 0.24 | V |
| | | Push-Pull, I _{OL} = 5 mA, 2X Drive | -- | 0.09 | 0.12 | V |
| | | Open Drain, I _{OL} = 5 mA, 1X Drive | -- | 0.12 | 0.16 | V |
| | | Open Drain, I _{OL} = 5 mA, 2X Drive | -- | 0.07 | 0.08 | V |
| | | Open Drain NMOS 4X, I _{OL} = 5 mA | -- | 0.03 | 0.05 | V |
| I _{OH} | HIGH-Level Output Pulse Current (see Note 1) | Push-Pull, V _{OH} = 2.4 V, 1X Drive | 22.08 | 34.04 | -- | mA |
| | | PMOS OD, V _{OH} = 2.4 V, 1X Drive | 22.08 | 34.04 | -- | mA |
| | | Push-Pull, V _{OH} = 2.4 V, 2X Drive | 41.76 | 68.08 | -- | mA |
| | | PMOS OD, V _{OH} = 2.4 V, 2X Drive | 41.69 | 68.08 | -- | mA |
| I _{OL} | LOW-Level Output Pulse Current (see Note 1) | Push-Pull, V _{OL} = 0.4 V, 1X Drive | 7.22 | 11.58 | -- | mA |
| | | Push-Pull, V _{OL} = 0.4 V, 2X Drive | 13.83 | 23.16 | -- | mA |
| | | Open Drain, V _{OL} = 0.4 V, 1X Drive | 10.82 | 17.38 | -- | mA |
| | | Open Drain, V _{OL} = 0.4 V, 2X Drive | 17.34 | 34.76 | -- | mA |
| | | Open Drain NMOS 4X, V _{OL} = 0.4 V | 41.06 | 55.18 | -- | mA |
| I _{VDD} | Maximum Average or DC Current Through V _{DD} Pin (Per chip side, see Note 2) | T _J = 85°C | -- | -- | 45 | mA |
| | | T _J = 110°C | -- | -- | 22 | mA |
| I _{GND} | Maximum Average or DC Current Through GND Pin (Per chip side, see Note 2) | T _J = 85°C | -- | -- | 86 | mA |
| | | T _J = 110°C | -- | -- | 41 | mA |

| Symbol | Parameter | Condition/Note | Min. | Typ. | Max. | Unit |
|--------------|--|--|------|------|----------|------------|
| V_O | Maximal Voltage Applied to any PIN in High-Impedance State | | -- | -- | V_{DD} | V |
| T_{SU} | Startup Time | From V_{DD} rising past PON_{THR} | 0.60 | 1.23 | 1.61 | ms |
| PON_{THR} | Power On Threshold | V_{DD} Level Required to Start Up the Chip | 1.41 | 1.54 | 1.66 | V |
| $POFF_{THR}$ | Power Off Threshold | V_{DD} Level Required to Switch Off the Chip | 1.00 | 1.15 | 1.31 | V |
| R_{PUP} | Pull Up Resistance | 1 M Pull Up | -- | 1 | -- | M Ω |
| | | 100 k Pull Up | -- | 100 | -- | k Ω |
| | | 10 k Pull Up | -- | 10 | -- | k Ω |
| R_{PDWN} | Pull Down Resistance | 1 M Pull Down | -- | 1 | -- | M Ω |
| | | 100 k Pull Down | -- | 100 | -- | k Ω |
| | | 10 k Pull Down | -- | 10 | -- | k Ω |

Note 1: DC or average current through any pin should not exceed value given in Absolute Maximum Conditions.

Note 2: The GreenPAK's power rails are divided in two sides. Pins 2, 3, 4, 5, 6, 7 and 8 are connected to one side, pins 10, 11, 12, 13 and 14 to another.

5.5 I²C Specifications

| Symbol | Parameter | Condition/Note | Min. | Typ. | Max. | Unit |
|---------------|---|----------------------------|------|------|------|------|
| F_{SCL} | Clock Frequency, SCL | $V_{DD} = (1.71...5.5) V$ | -- | -- | 400 | kHz |
| t_{LOW} | Clock Pulse Width Low | $V_{DD} = (1.71...5.5) V$ | 1300 | | | ns |
| t_{HIGH} | Clock Pulse Width High | $V_{DD} = (1.71...5.5) V$ | 600 | -- | -- | ns |
| t_i | Input Filter Spike Suppression (SCL, SDA) | $V_{DD} = 1.8 V \pm 5 \%$ | -- | -- | 95 | ns |
| | | $V_{DD} = 3.3 V \pm 10 \%$ | | | 95 | |
| | | $V_{DD} = 5.0 V \pm 10 \%$ | | | 111 | |
| t_{AA} | Clock Low to Data Out Valid | $V_{DD} = (1.71...5.5) V$ | -- | -- | 900 | ns |
| t_{BUF} | Bus Free Time between Stop and Start | $V_{DD} = (1.71...5.5) V$ | 1300 | -- | -- | ns |
| t_{HD_STA} | Start Hold Time | $V_{DD} = (1.71...5.5) V$ | 600 | -- | -- | ns |
| t_{SU_STA} | Start Set-up Time | $V_{DD} = (1.71...5.5) V$ | 600 | -- | -- | ns |
| t_{HD_DAT} | Data Hold Time | $V_{DD} = (1.71...5.5) V$ | 0 | -- | -- | ns |
| t_{SU_DAT} | Data Set-up Time | $V_{DD} = (1.71...5.5) V$ | 100 | -- | -- | ns |
| t_R | Inputs Rise Time | $V_{DD} = (1.71...5.5) V$ | -- | -- | 300 | ns |
| t_F | Inputs Fall Time | $V_{DD} = (1.71...5.5) V$ | -- | -- | 300 | ns |
| t_{SU_STO} | Stop Set-up Time | $V_{DD} = (1.71...5.5) V$ | 600 | -- | -- | ns |
| t_{DH} | Data Out Hold Time | $V_{DD} = (1.71...5.5) V$ | 50 | -- | -- | ns |

5.6 Asynchronous State Machine (ASM) Specifications
Table 1. ASM Specifications

| Symbol | Parameter | Condition | Min | Typ | Max | Unit |
|---------------|--|----------------------------------|-----|-----|-----|------|
| tst_out_delay | Asynchronous State Machine Output Delay Time | $V_{DD} = 1.8\text{ V} \pm 5\%$ | 104 | -- | 213 | ns |
| | | $V_{DD} = 3.3\text{ V} \pm 10\%$ | 44 | -- | 89 | |
| | | $V_{DD} = 5.0\text{ V} \pm 10\%$ | 32 | -- | 58 | |
| tst_out | Asynchronous State Machine Output Transition Time | $V_{DD} = 1.8\text{ V} \pm 5\%$ | -- | -- | 165 | ns |
| | | $V_{DD} = 3.3\text{ V} \pm 10\%$ | -- | -- | 70 | |
| | | $V_{DD} = 5.0\text{ V} \pm 10\%$ | -- | -- | 45 | |
| tst_pulse | Asynchronous State Machine Input Pulse Acceptance Time | $V_{DD} = 1.8\text{ V} \pm 5\%$ | 14 | -- | -- | ns |
| | | $V_{DD} = 3.3\text{ V} \pm 10\%$ | 6 | -- | -- | |
| | | $V_{DD} = 5.0\text{ V} \pm 10\%$ | 5 | -- | -- | |
| tst_comp | Asynchronous State Machine Input Compete Time | $V_{DD} = 1.8\text{ V} \pm 5\%$ | -- | -- | 20 | ns |
| | | $V_{DD} = 3.3\text{ V} \pm 10\%$ | -- | -- | 8 | |
| | | $V_{DD} = 5.0\text{ V} \pm 10\%$ | -- | -- | 5 | |

5.7 IDD Estimator
Table 2. Typical Current Estimated for Each Macrocell at T = 25°C

| Symbol | Parameter | Note | $V_{DD} = 1.8\text{ V}$ | $V_{DD} = 3.3\text{ V}$ | $V_{DD} = 5.0\text{ V}$ | Unit |
|--------|-----------|---------------------------|-------------------------|-------------------------|-------------------------|---------------|
| I | Current | Chip Quiescent | 0.45 | 0.75 | 1.12 | μA |
| | | OSC 2 MHz, predivide = 1 | 41.48 | 64.00 | 94.89 | μA |
| | | OSC 2 MHz, predivide = 8 | 25.68 | 32.41 | 43.22 | μA |
| | | OSC 25 kHz, predivide = 1 | 7.16 | 7.94 | 9.25 | μA |
| | | OSC 25 kHz, predivide = 8 | 6.97 | 7.60 | 8.68 | μA |
| | | OSC 25 MHz, predivide = 1 | 87.25 | 238.27 | 428.66 | μA |
| | | OSC 25 MHz, predivide = 8 | 78.01 | 212.45 | 390.17 | μA |
| | | ACMP (each) | 54.96 | 52.64 | 60.81 | μA |
| | | ACMP with buffer (each) | 75.06 | 72.74 | 81.25 | μA |
| | | Vref (each) | 49.70 | 47.32 | 55.60 | μA |
| | | Vref with Buffer (each) | 71.93 | 71.27 | 79.62 | μA |

5.8 Timing Estimator
Table 3. Typical Delay Estimated for Each Macrocell at T = 25°C

| Symbol | Parameter | Note | V _{DD} = 1.8 V | | V _{DD} = 3.3 V | | V _{DD} = 5.0 V | | Unit |
|--------|-----------|---|-------------------------|---------|-------------------------|---------|-------------------------|---------|------|
| | | | rising | falling | rising | falling | rising | falling | |
| tpd | Delay | Digital Input to PP 1X | 45 | 50 | 19 | 21 | 14 | 15 | ns |
| tpd | Delay | Digital Input with Schmitt Trigger to PP 1X | 44 | 49 | 19 | 21 | 14 | 15 | ns |
| tpd | Delay | Low Voltage Digital input to PP 1X | 46 | 447 | 19 | 195 | 14 | 134 | ns |
| tpd | Delay | Digital input to PMOS output | 44 | - | 19 | - | 14 | - | ns |
| tpd | Delay | Digital input to NMOS output | - | 81 | - | 30 | - | 20 | ns |
| tpd | Delay | Output enable from pin, OE Hi-Z to 1 | 48 | - | 20 | - | 15 | - | ns |
| tpd | Delay | Output enable from pin, OE Hi-Z to 0 | - | 46 | - | 20 | - | 14 | ns |
| tpd | Delay | LUT2bit (LATCH) | 34 | 33 | 14 | 13 | 10 | 9 | ns |
| tpd | Delay | LATCH (LUT2bit) | 30 | 34 | 14 | 13 | 10 | 9 | ns |
| tpd | Delay | LUT3bit (LATCH) | 38 | 37 | 18 | 15 | 13 | 10 | ns |
| tpd | Delay | LATCH+nRESET (LUT3bit) | 45 | 42 | 21 | 17 | 15 | 12 | ns |
| tpd | Delay | LATCH | 33 | 35 | 14 | 14 | 11 | 10 | ns |
| tpd | Delay | LUT4bit | 28 | 33 | 14 | 13 | 10 | 9 | ns |
| tpd | Delay | LUT2bit | 31 | 31 | 14 | 13 | 10 | 9 | ns |
| tpd | Delay | LUT3bit | 35 | 33 | 15 | 13 | 11 | 10 | ns |
| tpd | Delay | CNT/DLY Logic | 62 | 68 | 27 | 29 | 19 | 20 | ns |
| tpd | Delay | DFF | 32 | 28 | 14 | 12 | 11 | 9 | ns |
| tpd | Delay | P_DLY1C | 367 | 356 | 165 | 160 | 123 | 119 | ns |
| tpd | Delay | P_DLY2C | 667 | 656 | 303 | 297 | 225 | 221 | ns |
| tpd | Delay | P_DLY3C | 968 | 956 | 440 | 434 | 327 | 322 | ns |
| tpd | Delay | P_DLY4C | 1265 | 1252 | 576 | 570 | 428 | 423 | ns |
| tpd | Delay | Filter | 213 | 210 | 84 | 83 | 55 | 55 | ns |
| tpd | Delay | ACMP (5 mV overdrive, IN- = 600 mV) | 1600 | 1900 | 1500 | 1800 | 1600 | 1800 | ns |
| tw | width | IO with 1X push pull (min transmitted) | 20 | 20 | 20 | 20 | 20 | 20 | ns |
| tw | width | filter (min transmitted) | 150 | 150 | 55 | 55 | 35 | 35 | ns |

5.9 Typical Counter/Delay Offset Measurements
Table 4. Typical Counter/Delay Offset Measurements

| Parameter | RC OSC Freq | RC OSC Power | V _{DD} = 1.8 V | V _{DD} = 3.3 V | V _{DD} = 5.0 V | Unit |
|-------------------------------------|-------------|--------------|-------------------------|-------------------------|-------------------------|------|
| Offset (Power On Delay) | 25 kHz | auto | 1.6 | 1.6 | 1.6 | μs |
| Offset (Power On Delay), fast start | 25 kHz | auto | 2.1 | 2.1 | 2.1 | μs |
| Offset (Power On Delay) | 2 MHz | auto | 0.4 | 0.2 | 0.2 | μs |
| Offset (Power On Delay), fast start | 2 MHz | auto | 0.7 | 0.5 | 0.4 | μs |
| Offset (Power On Delay) | 25 MHz | auto | 0.01 | 0.05 | 0.04 | μs |
| Frequency settling time | 25 kHz | auto | 19 | 14 | 12 | μs |
| Frequency settling time | 2 MHz | auto | 14 | 14 | 14 | μs |
| Variable (CLK period) | 25 kHz | forced | 0-40 | 0-40 | 0-40 | μs |
| Variable (CLK period) | 2 MHz | forced | 0-0.5 | 0-0.5 | 0-0.5 | μs |
| Variable (CLK period) | 25 MHz | | 0-0.04 | 0-0.04 | 0-0.04 | μs |

Table 4. Typical Counter/Delay Offset Measurements

| Parameter | RC OSC Freq | RC OSC Power | V _{DD} = 1.8 V | V _{DD} = 3.3 V | V _{DD} = 5.0 V | Unit |
|------------------------------------|------------------|--------------|-------------------------|-------------------------|-------------------------|------|
| T _{pd} (non-delayed edge) | 25 kHz/ 2 MHz | either | 35 | 14 | 10 | ns |

5.10 Expected Delays and Widths

Table 5. Expected Delays and Widths (typical)

| Symbol | Parameter | Note | V _{DD} = 1.8 V | V _{DD} = 3.3 V | V _{DD} = 5.0 V | Unit |
|--------|---------------|---|-------------------------|-------------------------|-------------------------|------|
| Width | Width, 1 cell | mode:(any)edge detect, edge detect output | 296 | 135 | 101 | ns |
| Width | Width, 2 cell | mode:(any)edge detect, edge detect output | 597 | 272 | 203 | ns |
| Width | Width, 3 cell | mode:(any)edge detect, edge detect output | 898 | 410 | 305 | ns |
| Width | Width, 4 cell | mode:(any)edge detect, edge detect output | 1195 | 546 | 407 | ns |
| time1 | Delay, 1 cell | mode:(any)edge detect, edge detect output | 55 | 24 | 18 | ns |
| time1 | Delay, 2 cell | mode:(any)edge detect, edge detect output | 55 | 24 | 18 | ns |
| time1 | Delay, 3 cell | mode:(any)edge detect, edge detect output | 55 | 24 | 18 | ns |
| time1 | Delay, 4 cell | mode:(any)edge detect, edge detect output | 55 | 24 | 18 | ns |
| time2 | Delay, 1 cell | mode: both edge delay, edge detect output | 367 | 165 | 106 | ns |
| time2 | Delay, 2 cell | mode: both edge delay, edge detect output | 667 | 300 | 193 | ns |
| time2 | Delay, 3 cell | mode: both edge delay, edge detect output | 968 | 440 | 279 | ns |
| time2 | Delay, 4 cell | mode: both edge delay, edge detect output | 1265 | 575 | 365 | ns |

5.11 Typical Pulse Width Performance

Table 6. Typical Pulse Width Performance at T = 25°C

| Parameter | V _{DD} = 1.8 V | V _{DD} = 3.3 V | V _{DD} = 5.0 V | Unit |
|-----------------------------------|-------------------------|-------------------------|-------------------------|------|
| Filtered Pulse Width for Filter 0 | < 114 | < 47 | < 30 | ns |
| Filtered Pulse Width for Filter 1 | <75 | <30 | <19 | ns |

5.12 OSC Specifications
Table 7. 25 kHz RC OSC0 frequency limits

| Power Supply Range (V _{DD}) V | Temperature Range | | | | | |
|--|--------------------|--------------------|--------------------|--------------------|--------------------|--------------------|
| | +25 °C | | 0 °C ... +85 °C | | -40 °C ... +85 °C | |
| | Minimum Value, kHz | Maximum Value, kHz | Minimum Value, kHz | Maximum Value, kHz | Minimum Value, kHz | Maximum Value, kHz |
| 1.8 V ±5% | 23.792 | 26.288 | 23.275 | 27.089 | 21.728 | 29.173 |
| 3.3 V ±10% | 24.473 | 25.526 | 23.357 | 26.028 | 23.357 | 27.002 |
| 5 V ±10% | 24.316 | 25.939 | 23.309 | 26.177 | 23.309 | 27.181 |
| 2.5 V ... 4.5 V | 24.438 | 25.559 | 23.336 | 26.051 | 23.336 | 27.038 |
| 1.71 V... 5.5 V | 23.354 | 26.670 | 22.828 | 27.483 | 21.301 | 29.545 |

Table 8. 25 kHz RC OSC0 frequency error (error calculated relative to nominal value)

| Power Supply Range (V _{DD}) V | Temperature Range | | | | | |
|--|----------------------|----------------------|----------------------|----------------------|----------------------|----------------------|
| | +25 °C | | 0 °C ... +85 °C | | -40 °C ... +85 °C | |
| | Error (% at Minimum) | Error (% at Maximum) | Error (% at Minimum) | Error (% at Maximum) | Error (% at Minimum) | Error (% at Maximum) |
| 1.8 V ±5% | -4.83% | 5.15% | -6.90% | 8.36% | -13.09% | 16.69% |
| 3.3 V ±10% | -2.11% | 2.10% | -6.57% | 4.11% | -6.57% | 8.01% |
| 5 V ±10% | -2.73% | 3.76% | -6.76% | 4.71% | -6.76% | 8.72% |
| 2.5 V ... 4.5 V | -2.25% | 2.24% | -6.66% | 4.21% | -6.66% | 8.15% |
| 1.71 V... 5.5 V | -6.58% | 6.68% | -8.69% | 9.93% | -14.80% | 18.18% |

5.12.1 2 MHz RC Oscillator
Table 9. 2 MHz RC OSC0 frequency limits

| Power Supply Range (V _{DD}) V | Temperature Range | | | | | |
|--|--------------------|--------------------|--------------------|--------------------|--------------------|--------------------|
| | +25 °C | | 0 °C ... +85 °C | | -40 °C ... +85 °C | |
| | Minimum Value, MHz | Maximum Value, MHz | Minimum Value, MHz | Maximum Value, MHz | Minimum Value, MHz | Maximum Value, MHz |
| 1.8 V ±5% | 1.915 | 2.062 | 1.832 | 2.103 | 1.810 | 2.144 |
| 3.3 V ±10% | 1.937 | 2.070 | 1.858 | 2.132 | 1.813 | 2.145 |
| 5 V ±10% | 1.894 | 2.233 | 1.853 | 2.270 | 1.767 | 2.270 |
| 2.5 V ... 4.5 V | 1.907 | 2.124 | 1.836 | 2.171 | 1.784 | 2.171 |
| 1.71 V... 5.5 V | 1.760 | 2.274 | 1.706 | 2.305 | 1.629 | 2.305 |

Table 10. 2 MHz RC OSC0 frequency error (error calculated relative to nominal value)

| Power Supply Range (V _{DD}) V | Temperature Range | | | | | |
|--|----------------------|----------------------|----------------------|----------------------|----------------------|----------------------|
| | +25 °C | | 0 °C ... +85 °C | | -40 °C ... +85 °C | |
| | Error (% at Minimum) | Error (% at Maximum) | Error (% at Minimum) | Error (% at Maximum) | Error (% at Minimum) | Error (% at Maximum) |
| 1.8 V ±5% | -4.26% | 3.12% | -8.38% | 5.17% | -9.50% | 7.20% |
| 3.3 V ±10% | -3.14% | 3.49% | -7.10% | 6.58% | -9.33% | 7.24% |
| 5 V ±10% | -5.31% | 11.66% | -7.37% | 13.50% | -11.67% | 13.50% |
| 2.5 V ... 4.5 V | -4.65% | 6.18% | -8.22% | 8.57% | -10.81% | 8.57% |
| 1.71 V... 5.5 V | -12.01% | 13.72% | -14.69% | 15.23% | -18.57% | 15.23% |

5.12.2 25 MHz RC Oscillator
Table 11. 25 MHz RC OSC1 frequency limits

| Power Supply Range (V _{DD}) V | Temperature Range | | | | | |
|--|--------------------|--------------------|--------------------|--------------------|--------------------|--------------------|
| | +25 °C | | 0 °C ... +85 °C | | -40 °C ... +85 °C | |
| | Minimum Value, MHz | Maximum Value, MHz | Minimum Value, MHz | Maximum Value, MHz | Minimum Value, MHz | Maximum Value, MHz |
| 2.5 V ±10% | 22.316 | 27.220 | 21.771 | 27.572 | 21.771 | 27.912 |
| 3.3 V ±10% | 23.430 | 26.220 | 22.389 | 26.679 | 22.389 | 27.014 |
| 5 V ±10% | 23.289 | 26.651 | 22.500 | 27.305 | 22.500 | 27.486 |
| 2.5 V ... 4.5 V | 23.383 | 26.220 | 20.725 | 26.679 | 20.725 | 27.014 |
| 1.71 V... 5.5 V | 12.643 | 26.220 | 12.203 | 26.679 | 11.317 | 27.014 |

Table 12. 25 MHz RC OSC1 frequency error (error calculated relative to nominal value)

| Power Supply Range (V _{DD}) V | Temperature Range | | | | | |
|--|----------------------|----------------------|----------------------|----------------------|----------------------|----------------------|
| | +25 °C | | 0 °C ... +85 °C | | -40 °C ... +85 °C | |
| | Error (% at Minimum) | Error (% at Maximum) | Error (% at Minimum) | Error (% at Maximum) | Error (% at Minimum) | Error (% at Maximum) |
| 2.5 V ±10% | -10.73% | 8.88% | -12.92% | 10.29% | -12.92% | 11.65% |
| 3.3 V ±10% | -6.28% | 4.88% | -10.44% | 6.72% | -10.44% | 8.06% |
| 5 V ±10% | -6.84% | 6.61% | -10.00% | 9.22% | -10.00% | 9.95% |
| 2.5 V ... 4.5 V | -14.47% | 4.88% | -17.10% | 6.72% | -17.10% | 8.06% |
| 1.71 V... 5.5 V | -49.43% | 4.88% | -51.19% | 6.72% | -54.73% | 8.06% |

Note: 25 MHz RC OSC1 performance is not guaranteed at V_{DD} < 2.5 V.

5.12.3 OSC Power On delay
Table 13. Oscillators Power On delay at room temperature, DLY/CNT Counter data = 100; RC OSC power setting: "Auto Power On", RC osc clock to matrix input: "Enable"

| Power Supply Range (V _{DD}) V | RC OSC0 2 MHz | | RC OSC0 25 kHz | | RC OSC1 | |
|---|-------------------|-------------------|-------------------|-------------------|-------------------|-------------------|
| | Typical Value, ns | Maximum Value, ns | Typical Value, μs | Maximum Value, μs | Typical Value, ns | Maximum Value, ns |
| 1.71 | 372.7 | 407.3 | 0.40 | 0.57 | 71.2 | 87.3 |
| 1.80 | 349.2 | 379.5 | 0.38 | 0.41 | 65.0 | 78.7 |
| 1.89 | 330.3 | 358.0 | 0.35 | 0.41 | 59.7 | 71.3 |
| 2.30 | 277.2 | 298.1 | 0.29 | 0.31 | 43.0 | 54.0 |
| 2.50 | 262.0 | 281.9 | 0.28 | 0.30 | 39.6 | 48.1 |
| 2.70 | 250.2 | 269.8 | 0.26 | 0.30 | 36.7 | 43.5 |
| 3.00 | 236.6 | 256.7 | 0.25 | 0.44 | 33.2 | 39.8 |
| 3.30 | 226.7 | 247.4 | 0.23 | 0.47 | 30.4 | 36.8 |
| 3.60 | 219.0 | 239.9 | 0.22 | 0.46 | 28.2 | 34.3 |
| 4.20 | 207.4 | 229.2 | 0.37 | 0.50 | 25.8 | 30.6 |
| 4.50 | 202.8 | 224.5 | 1.63 | 1.92 | 25.0 | 29.2 |
| 5.00 | 196.3 | 218.7 | 1.67 | 2.05 | 24.3 | 27.5 |
| 5.50 | 190.8 | 213.3 | 1.69 | 1.99 | 23.7 | 26.8 |

Table 14. Oscillators Power On delay at room temperature, DLY/CNT Counter data = 100; RC OSC power setting: "Auto Power On", RC osc clock to matrix input: "Enable", Fast Start-up Time Mode

| Power Supply Range (V _{DD}) V | RC OSC0 2 MHz | | RC OSC1 25 kHz | |
|---|-------------------|-------------------|-------------------|-------------------|
| | Typical Value, ns | Maximum Value, ns | Typical Value, μs | Maximum Value, μs |
| 1.71 | 327.9 | 360.0 | 0.68 | 0.76 |
| 1.80 | 309.9 | 338.3 | 0.64 | 0.64 |
| 1.89 | 295.5 | 323.1 | 0.61 | 0.70 |
| 2.30 | 254.9 | 278.1 | 0.53 | 21.93 |
| 2.50 | 243.1 | 266.1 | 3.23 | 21.88 |
| 2.70 | 234.1 | 257.1 | 16.68 | 21.94 |
| 3.00 | 223.7 | 246.8 | 19.25 | 21.90 |
| 3.30 | 215.7 | 239.1 | 19.22 | 21.77 |
| 3.60 | 209.4 | 232.9 | 19.21 | 21.74 |
| 4.20 | 199.5 | 223.4 | 19.17 | 21.78 |
| 4.50 | 195.5 | 219.8 | 19.15 | 21.69 |
| 5.00 | 189.8 | 214.6 | 19.12 | 21.71 |
| 5.50 | 184.9 | 209.8 | 19.05 | 21.75 |

5.13 ACMP Specifications
Table 15. ACMP Specifications

| Symbol | Parameter | Description/Note | Conditions | Min. | Typ. | Max. | Unit |
|--------------|---------------------------|--|--|-------|-------|----------|---------------|
| V_{ACMP} | ACMP Input Voltage Range | Positive Input | $V_{DD} = 1.8\text{ V} \pm 5\%$ | 0 | -- | V_{DD} | V |
| | | Negative Input | | 0 | -- | 1.2 | V |
| | | Positive Input | $V_{DD} = 3.3\text{ V} \pm 10\%$ | 0 | -- | V_{DD} | V |
| | | Negative Input | | 0 | -- | 1.2 | V |
| | | Positive Input | $V_{DD} = 5.0\text{ V} \pm 10\%$ | 0 | -- | V_{DD} | V |
| | | Negative Input | | 0 | -- | 1.2 | V |
| V_{offset} | ACMP Input Offset Voltage | Low Bandwidth - Enable, $V_{phys} = 0\text{ mV}$, Gain = 1, $V_{ref} = (50..1200)\text{ mV}$, $V_{DD} = (1.71..5.5)\text{ V}$ | $T = 25^\circ\text{C}$ | -9.1 | -- | 8.4 | mV |
| | | | $T = (-40..85)^\circ\text{C}$ | -10.9 | -- | 10.9 | mV |
| | | Low Bandwidth - Disable, $V_{phys} = 0\text{ mV}$, Gain = 1, $V_{ref} = (50..1200)\text{ mV}$, $V_{DD} = (1.71..5.5)\text{ V}$ | $T = 25^\circ\text{C}$ | -7.5 | -- | 7.2 | mV |
| | | | $T = (-40..85)^\circ\text{C}$ | -10.7 | -- | 10.5 | mV |
| t_{start} | ACMP Start Time | ACMP Power On delay, Minimal required wake time for the "Wake and Sleep function", Regulator and Charge Pump set to automatic ON/OFF | BG = 550 μs , $T = 25^\circ\text{C}$ $V_{DD} = (1.71..5.5)\text{ V}$ | -- | 609.7 | 862.2 | μS |
| | | | BG = 550 μs , $T = (-40..85)^\circ\text{C}$ $V_{DD} = (1.71..5.5)\text{ V}$ | -- | 675.0 | 1028.8 | μS |
| | | | BG = 100 μs , $T = 25^\circ\text{C}$ $V_{DD} = 2.7..5.5\text{ V}$ | -- | 132.4 | 176.2 | μS |
| | | | BG = 100 μs , $T = (-40..85)^\circ\text{C}$ $V_{DD} = 2.7..5.5\text{ V}$ | -- | 149.4 | 213.5 | μS |
| | | ACMP Power On delay, Minimal required wake time for the "Wake and Sleep function", Regulator and Charge Pump always OFF | BG = 550 μs , $T = 25^\circ\text{C}$ $V_{DD} = (3..5.5)\text{ V}$ | -- | 609.5 | 862.0 | μS |
| | | | BG = 550 μs , $T = (-40..85)^\circ\text{C}$ $V_{DD} = (3..5.5)\text{ V}$ | -- | 674.6 | 1027.5 | μS |
| | | | BG = 100 μs , $T = 25^\circ\text{C}$ $V_{DD} = 3..5.5\text{ V}$ | -- | 131.6 | 176.0 | μS |
| | | | BG = 100 μs , $T = (-40..85)^\circ\text{C}$ $V_{DD} = 3..5.5\text{ V}$ | -- | 149.2 | 213.3 | μS |

| Symbol | Parameter | Description/Note | Conditions | Min. | Typ. | Max. | Unit | | |
|------------------|-------------------------------------|--|-------------------------------------|-------------|-------|--------|-------|----|----|
| V _{HYS} | Built-in Hysteresis | V _{HYS} = 25 mV V _{IL} = V _{in} - V _{HYS} /2 V _{IH} = V _{in} + V _{HYS} /2 | LB - Enabled, T = 25°C | 7.32 | -- | 35.5 | mV | | |
| | | | LB - Disabled, T = 25°C | 10.0 | -- | 38.5 | mV | | |
| | | V _{HYS} = 50 mV V _{IL} = V _{in} - V _{HYS} V _{IH} = V _{HYS} | LB - Enabled, T = 25°C | 42.9 | -- | 57.8 | mV | | |
| | | | LB - Disabled, T = 25°C | 44.2 | -- | 54.3 | mV | | |
| | | V _{HYS} = 200 mV V _{IL} = V _{in} - V _{HYS} V _{IH} = V _{HYS} | LB - Enabled, T = 25°C | 192.7 | -- | 208.7 | mV | | |
| | | | LB - Disabled, T = 25°C | 193.3 | -- | 204.8 | mV | | |
| | | V _{HYS} = 25 mV V _{IL} = V _{in} - V _{HYS} /2 V _{IH} = V _{in} + V _{HYS} /2 | LB - Enabled, T = (-40...+85)°C | 0.0 | -- | 58.0 | mV | | |
| | | | LB - Disabled, T = (-40...+85)°C | 0.0 | -- | 52.9 | mV | | |
| | | V _{HYS} = 50 mV V _{IL} = V _{in} - V _{HYS} V _{IH} = V _{HYS} | LB - Enabled, T = (-40...+85)°C | 22.5 | -- | 86.9 | mV | | |
| | | | LB - Disabled, T = (-40...+85)°C | 29.2 | -- | 76.5 | mV | | |
| | | V _{HYS} = 200 mV V _{IL} = V _{in} - V _{HYS} V _{IH} = V _{HYS} | LB - Enabled, T = (-40...+85)°C | 157.1 | -- | 251.6 | mV | | |
| | | | LB - Disabled, T = (-40...+85)°C | 160.2 | -- | 245.3 | mV | | |
| | | R _{sin} | Series Input Resistance | Gain = 1x | | -- | 100.0 | -- | MΩ |
| | | | | Gain = 0.5x | | -- | 1.0 | -- | MΩ |
| Gain = 0.33x | | | | -- | 0.8 | -- | MΩ | | |
| Gain = 0.25x | | | | -- | 1.0 | -- | MΩ | | |
| PROP | Propagation Delay, Response Time | Low Bandwidth - Enable, Gain = 1, V _{DD} = (1.71..3.3)V, Overdrive = 5 mV, V _{ref} = 50 mV | Low to High, T = (-40...+85)°C | -- | 35.99 | 216.56 | μs | | |
| | | | High to Low, T = (-40...+85)°C | -- | 39.36 | 208.81 | μs | | |
| | | Low Bandwidth - Disable, Gain = 1, V _{DD} = (1.71..3.3)V, Overdrive = 5 mV, V _{ref} = 50 mV | Low to High, T = (-40...+85)°C | -- | 1.85 | 3.04 | μs | | |
| | | | High to Low, T = (-40...+85)°C | -- | 2.17 | 4.10 | μs | | |
| | | Low Bandwidth - Enable, Gain = 1, V _{DD} = (3.3..5.5)V, Overdrive = 5 mV, V _{ref} = 50 mV | Low to High, T = (-40...+85)°C | -- | 25.22 | 129.31 | μs | | |
| | | | High to Low, T = (-40...+85)°C | -- | 28.31 | 145.47 | μs | | |
| | | Low Bandwidth - Disable, Gain = 1, V _{DD} = (3.3..5.5)V, Overdrive = 5 mV, V _{ref} = 50 mV | Low to High, T = (-40...+85)°C | -- | 1.55 | 2.63 | μs | | |
| | | | High to Low, T = (-40...+85)°C | -- | 1.93 | 3.83 | μs | | |

| Symbol | Parameter | Description/Note | Conditions | Min. | Typ. | Max. | Unit |
|---|---|---|---|--------|---------|--------|---------|
| PROP | Propagation Delay, Response Time | Low Bandwidth - Enable, Gain = 1, $V_{DD} = (1.71..3.3)V$, Overdrive = 5 mV, $V_{ref} = 250$ mV | Low to High, $T = (-40...+85)^{\circ}C$ | -- | 36.46 | 216.78 | μs |
| | | | High to Low, $T = (-40...+85)^{\circ}C$ | -- | 39.79 | 216.05 | μs |
| | | Low Bandwidth - Disable, Gain = 1, $V_{DD} = (1.71..3.3)V$, Overdrive = 5 mV, $V_{ref} = 250$ mV | Low to High, $T = (-40...+85)^{\circ}C$ | -- | 2.04 | 3.37 | μs |
| | | | High to Low, $T = (-40...+85)^{\circ}C$ | -- | 2.21 | 4.12 | μs |
| | | Low Bandwidth - Enable, Gain = 1, $V_{DD} = (3.3..5.5)V$, Overdrive = 5 mV, $V_{ref} = 250$ mV | Low to High, $T = (-40...+85)^{\circ}C$ | -- | 25.81 | 132.94 | μs |
| | | | High to Low, $T = (-40...+85)^{\circ}C$ | -- | 28.65 | 142.43 | μs |
| | | Low Bandwidth - Disable, Gain = 1, $V_{DD} = (3.3..5.5)V$, Overdrive = 5 mV, $V_{ref} = 250$ mV | Low to High, $T = (-40...+85)^{\circ}C$ | -- | 1.74 | 2.93 | μs |
| | | | High to Low, $T = (-40...+85)^{\circ}C$ | -- | 1.97 | 3.96 | μs |
| | | Low Bandwidth - Enable, Gain = 1, $V_{DD} = (1.71..3.3)V$, Overdrive = 5 mV, $V_{ref} = 600$ mV | Low to High, $T = (-40...+85)^{\circ}C$ | -- | 37.36 | 222.82 | μs |
| | | | High to Low, $T = (-40...+85)^{\circ}C$ | -- | 40.67 | 219.61 | μs |
| | | Low Bandwidth - Disable, Gain = 1, $V_{DD} = (1.71..3.3)V$, Overdrive = 5 mV, $V_{ref} = 600$ mV | Low to High, $T = (-40...+85)^{\circ}C$ | -- | 2.23 | 4.02 | μs |
| | | | High to Low, $T = (-40...+85)^{\circ}C$ | -- | 2.23 | 4.33 | μs |
| | | Low Bandwidth - Enable, Gain = 1, $V_{DD} = (3.3..5.5)V$, Overdrive = 5 mV, $V_{ref} = 600$ mV | Low to High, $T = (-40...+85)^{\circ}C$ | -- | 26.41 | 135.47 | μs |
| | | | High to Low, $T = (-40...+85)^{\circ}C$ | -- | 29.32 | 149.01 | μs |
| | | Low Bandwidth - Disable, Gain = 1, $V_{DD} = (3.3..5.5)V$, Overdrive = 5 mV, $V_{ref} = 600$ mV | Low to High, $T = (-40...+85)^{\circ}C$ | -- | 1.92 | 3.53 | μs |
| | | | High to Low, $T = (-40...+85)^{\circ}C$ | -- | 2.00 | 4.25 | μs |
| | | Low Bandwidth - Enable, Gain = 1, $V_{DD} = (1.71..3.3)V$, Overdrive = 5 mV, $V_{ref} = 850$ mV | Low to High, $T = (-40...+85)^{\circ}C$ | -- | 38.36 | 232.64 | μs |
| | | | High to Low, $T = (-40...+85)^{\circ}C$ | -- | 41.67 | 232.78 | μs |
| | | Low Bandwidth - Disable, Gain = 1, $V_{DD} = (1.71..3.3)V$, Overdrive = 5 mV, $V_{ref} = 850$ mV | Low to High, $T = (-40...+85)^{\circ}C$ | -- | 2.26 | 4.20 | μs |
| | | | High to Low, $T = (-40...+85)^{\circ}C$ | -- | 2.25 | 4.60 | μs |
| Low Bandwidth - Enable, Gain = 1, $V_{DD} = (3.3..5.5)V$, Overdrive = 5 mV, $V_{ref} = 850$ mV | Low to High, $T = (-40...+85)^{\circ}C$ | -- | 27.08 | 137.02 | μs | | |
| | High to Low, $T = (-40...+85)^{\circ}C$ | -- | 29.89 | 146.92 | μs | | |

| Symbol | Parameter | Description/Note | Conditions | Min. | Typ. | Max. | Unit |
|----------------------------|---|--|---|--------|--------|---------|---------|
| PROP | Propagation Delay, Response Time | Low Bandwidth - Disable, Gain = 1, $V_{DD} = (3.3..5.5)V$, Overdrive = 5 mV, $V_{ref} = 850$ mV | Low to High, $T = (-40...+85)^{\circ}C$ | -- | 1.91 | 3.57 | μs |
| | | | High to Low, $T = (-40...+85)^{\circ}C$ | -- | 1.98 | 4.34 | μs |
| | | Low Bandwidth - Enable, Gain = 1, $V_{DD} = (1.71..3.3)V$, Overdrive = 5 mV, $V_{ref} = 1200$ mV | Low to High, $T = (-40...+85)^{\circ}C$ | -- | 103.93 | 1853.68 | μs |
| | | | High to Low, $T = (-40...+85)^{\circ}C$ | -- | 101.06 | 1656.70 | μs |
| | | Low Bandwidth - Disable, Gain = 1, $V_{DD} = (1.71..3.3)V$, Overdrive = 5 mV, $V_{ref} = 1200$ mV | Low to High, $T = (-40...+85)^{\circ}C$ | -- | 68.29 | 1753.33 | μs |
| | | | High to Low, $T = (-40...+85)^{\circ}C$ | -- | 63.06 | 1568.55 | μs |
| | | Low Bandwidth - Enable, Gain = 1, $V_{DD} = (3.3..5.5)V$, Overdrive = 5 mV, $V_{ref} = 1200$ mV | Low to High, $T = (-40...+85)^{\circ}C$ | -- | 30.62 | 167.56 | μs |
| | | | High to Low, $T = (-40...+85)^{\circ}C$ | -- | 33.54 | 181.40 | μs |
| | | Low Bandwidth - Disable, Gain = 1, $V_{DD} = (3.3..5.5)V$, Overdrive = 5 mV, $V_{ref} = 1200$ mV | Low to High, $T = (-40...+85)^{\circ}C$ | -- | 5.00 | 32.61 | μs |
| | | | High to Low, $T = (-40...+85)^{\circ}C$ | -- | 5.24 | 33.88 | μs |
| G | Gain error (including threshold and internal V_{ref} error), $T = (-40...+85)^{\circ}C$ | $V_{ref} = 50...1200$ mV | G = 1, $V_{DD} = 1.71$ V | -- | 1 | -- | |
| | | | G = 1, $V_{DD} = 3.3$ V | -- | 1 | -- | |
| | | | G = 1, $V_{DD} = 5.5$ V | -- | 1 | -- | |
| | | | G = 0.5, $V_{DD} = 1.71$ V | -1.00% | -- | 0.93% | |
| | | | G = 0.5, $V_{DD} = 3.3$ V | -0.96% | -- | 0.82% | |
| | | | G = 0.5, $V_{DD} = 5.5$ V | -1.04% | -- | 0.90% | |
| | | | G = 0.33, $V_{DD} = 1.71V$ | -1.75% | -- | 2.10% | |
| | | | G = 0.33, $V_{DD} = 3.3$ V | -1.95% | -- | 1.69% | |
| | | | G = 0.33, $V_{DD} = 5.5$ V | -2.03% | -- | 1.77% | |
| | | | G = 0.25, $V_{DD} = 1.71V$ | -1.91% | -- | 2.13% | |
| | | | G = 0.25, $V_{DD} = 3.3$ V | -1.98% | -- | 1.80% | |
| G = 0.25, $V_{DD} = 5.5$ V | -2.12% | -- | 1.90% | | | | |

| Symbol | Parameter | Description/Note | Conditions | Min. | Typ. | Max. | Unit |
|--------|--|--------------------------------|-------------------|--------|------|-------|------|
| Vref | Internal Vref error, Vref = 1200 mV | V _{DD} = 1.8 V ± 5 % | T = 25°C | -0.58% | -- | 0.56% | |
| | | | T = (-40...+85)°C | -1.01% | -- | 0.70% | |
| | | V _{DD} = 3.3 V ± 10 % | T = 25°C | -0.59% | -- | 0.58% | |
| | | | T = (-40...+85)°C | -1.06% | -- | 0.72% | |
| | | V _{DD} = 5.0 V ± 10 % | T = 25°C | -0.64% | -- | 0.60% | |
| | | | T = (-40...+85)°C | -1.16% | -- | 0.74% | |
| | Internal Vref error, Vref = 1000 mV | V _{DD} = 1.8 V ± 5 % | T = 25°C | -0.57% | -- | 0.58% | |
| | | | T = (-40...+85)°C | -1.14% | -- | 0.76% | |
| | | V _{DD} = 3.3 V ± 10 % | T = 25°C | -0.59% | -- | 0.58% | |
| | | | T = (-40...+85)°C | -1.04% | -- | 0.73% | |
| | | V _{DD} = 5.0 V ± 10 % | T = 25°C | -0.67% | -- | 0.64% | |
| | | | T = (-40...+85)°C | -1.15% | -- | 0.73% | |
| | Internal Vref error, Vref = 500 mV | V _{DD} = 1.8 V ± 5 % | T = 25°C | -0.64% | -- | 0.64% | |
| | | | T = (-40...+85)°C | -1.11% | -- | 0.75% | |
| | | V _{DD} = 3.3 V ± 10 % | T = 25°C | -0.63% | -- | 0.63% | |
| | | | T = (-40...+85)°C | -1.10% | -- | 0.78% | |
| | | V _{DD} = 5.0 V ± 10 % | T = 25°C | -0.72% | -- | 0.70% | |
| | | | T = (-40...+85)°C | -1.15% | -- | 0.80% | |

6.0 Summary of Macrocell Function

6.1 IO Pins

- Digital Input (low voltage or normal voltage, with or without Schmitt Trigger)
- Open Drain Outputs
- Push Pull Outputs
- Analog IO
- 10 k Ω /100 k Ω /1 M Ω pull-up/pull-down resistors
- 40 mA Open Drain 4X Drive output

6.2 Connection Matrix

- Digital matrix for circuit connections based on user design

6.3 Analog Comparators (3 total)

- Selectable hysteresis 0 mV / 25 mV / 50 mV / 200 mV
- Wake and Sleep Control (Part of Combination Function Macrocell)

6.4 Voltage Reference

- Used for references on Analog Comparators

6.5 Combination Function Macrocells (19 total)

- Three Selectable DFF/Latch or 2-bit LUTs
- Five Selectable DFF/Latch or 3-bit LUTs
- One Selectable Pipe Delay or 3-bit LUT
- One Selectable Programmable Pattern Generator or 2-bit LUT
- Five Selectable 8-bit CNT/DLY or 3-bit LUT
- Two Selectable 16-bit CNT/DLY or 4-bit LUT or Wake and Sleep Controller
- Two Deglitch Filters with Edge Detectors

6.6 Asynchronous State Machine

- Eight States
- Flexible input logic from state transitions

6.7 Serial Communications

- I²C Protocol compliant

6.8 Pipe Delay (Part of Combination Function Macrocell)

- 16 stage / 3 output
- One 1 stage fixed output
- Two 1-16 stage selectable outputs

6.9 Programmable Delay

- 125 ns/250 ns/375 ns/500 ns @ 3.3 V
- Includes Edge Detection function

6.10 RC Oscillator

- 25 kHz and 2 MHz selectable frequency
- 25 MHz RC Oscillator
- First stage divider (4): OSC/1, OSC/2, OSC/4, and OSC/8
- Second stage divider for 25 kHz and 2 MHz (5): Output to Matrix: OSC/1, OSC/2, OSC/3, OSC/4, OSC/8, OSC/12, OSC/24, OSC/64

6.11 Crystal Oscillator
6.12 Eight byte RAM + OTP User Memory

- RAM Memory space that is readable and writable via I²C

7.0 IO Pins

The SLG46534 has a total of 12 multi-function IO pins which can function as either a user defined Input or Output, as well as serving as a special function, or serving as a signal for programming of the on-chip Non Volatile Memory (NVM).

Refer to Section 2.0 *Pin Description* for normal and programming mode pin definitions.

Normal Mode pin definitions are as follows:

- Pin 1: V_{DD} power supply
- Pin 2: general purpose input
- Pin 3: general purpose input or output
- Pin 4: general purpose input or output or analog comparator 0(+)
- Pin 5: general purpose input or output with OE or analog comparator 0(-)
- Pin 6: general purpose input or OD output SCL
- Pin 7: general purpose input or OD output SDA
- Pin 8: general purpose input or output with OE or analog comparator 1(+)
- Pin 9: ground
- Pin 10: general purpose input or output or analog comparator 0/1/2(-)
- Pin 11: general purpose input or output with OE
- Pin 12: general purpose input or output with OE
- Pin 13: general purpose input or output or external clock input for OSC0 25 kHz/2 MHz
- Pin 14: general purpose input or output or external clock input for OSC1 25 MHz

Programming Mode pin definitions are as follows:

- Pin 1: V_{DD} power supply
- Pin 2: V_{PP} programming voltage
- Pin 6: Programming SCL
- Pin 7: Programming SDA
- Pin 9: ground
- Pin 12: programming mode control

Of the 12 user defined IO pins on the SLG46534, all but one of the pins (Pin 2) can serve as both digital input and digital output. Pin 2 can only serve as a digital input pin.

7.1 Input Modes

Each IO pin can be configured as a digital input pin with/without buffered Schmitt Trigger, or can also be configured as a low voltage digital input. Pins 4, 5, 8 and 10 can also be configured to serve as analog inputs to the on-chip comparators.

7.2 Output Modes

Pins 3, 4, 5, 6, 7, 8, 10, 11, 12, 13 and 14 can all be configured as digital output pins.

7.3 Pull Up/Down Resistors

All IO pins have the option for user selectable resistors connected to the input structure. The selectable values on these resistors are 10 k Ω , 100 k Ω and 1 M Ω . In the case of Pin 2, the resistors are fixed to a pull-down configuration. In the case of all other IO pins, the internal resistors can be configured as either pull-up or pull-downs.

7.4 IO Register Settings
7.4.1 PIN 2 Register Settings PIN 4 Register Settings PIN 6 Register Settings
Table 16. PIN 2 Register Settings

| Signal Function | Register Bit Address | Register Definition |
|--|----------------------|--|
| PIN 2 Pull Down Resistor Value Selection | <1029:1028> | 00: Floating 01: 10 kΩ Resistor 10: 100 kΩ Resistor 11: 1 MΩ Resistor |
| PIN 2 Mode Control | <1031:1030> | 00: Digital Input without Schmitt Trigger 01: Digital Input with Schmitt Trigger 10: Low Voltage Digital Input 11: Reserved |

Table 17. PIN 3 Register Settings

| Signal Function | Register Bit Address | Register Definition |
|---|----------------------|---|
| PIN 3 Driver Strength Selection | <1041> | 0: 1X 1: 2X |
| PIN 3 Pull Up/Down Resistor Selection | <1042> | 0: Pull Down Resistor 1: Pull Up Resistor |
| PIN 3 Pull Up/Down Resistor Value Selection | <1044:1043> | 00: Floating 01: 10 kΩ Resistor 10: 100 kΩ Resistor 11: 1 MΩ Resistor |
| PIN 3 Mode Control | <1047:1045> | 000: Digital Input without Schmitt Trigger 001: Digital Input with Schmitt Trigger 010: Low Voltage Digital Input 011: Reserved 100: Push Pull 101: Open Drain NMOS 110: Open Drain PMOS 111: Reserved |

Table 18. PIN 4 Register Settings

| Signal Function | Register Bit Address | Register Definition |
|---|----------------------|---|
| PIN 4 Driver Strength Selection | <1057> | 0: 1X 1: 2X |
| PIN 4 Pull Up/Down Resistor Selection | <1058> | 0: Pull Down Resistor 1: Pull Up Resistor |
| PIN 4 Pull Up/Down Resistor Value Selection | <1060:1059> | 00: Floating 01: 10 kΩ Resistor 10: 100 kΩ Resistor 11: 1 MΩ Resistor |
| PIN 4 Mode Control | <1063:1061> | 000: Digital Input without Schmitt Trigger 001: Digital Input with Schmitt Trigger 010: Low Voltage Digital Input 011: Analog Input/Output 100: Push Pull 101: Open Drain NMOS 110: Open Drain PMOS 111: Analog Input & Open Drain |

7.4.2 PIN 5 Register Settings
Table 19. PIN 5 Register Settings

| Signal Function | Register Bit Address | Register Definition |
|---|----------------------|---|
| PIN 5 Pull Up/Down Resistor Selection | <1065> | 0: Pull Down Resistor 1: Pull Up Resistor |
| PIN 5 Pull Up/Down Resistor Value Selection | <1067:1066> | 00: Floating 01: 10 kΩ Resistor 10: 100 kΩ Resistor 11: 1 MΩ Resistor |
| PIN 5 Mode Control (sig_pin5_oe = 0) | <1069:1068> | 00: Digital Input without Schmitt Trigger 01: Digital Input with Schmitt Trigger 10: Low Voltage Digital Input 11: Analog Input/Output |
| PIN 5 Mode Control (sig_pin5_oe = 1) | <1071:1070> | 00: Push Pull 1X 01: Push Pull 2X 10: Open Drain NMOS 1X 11: Open Drain NMOS 2X |

7.4.3 PIN 6 Register Settings
Table 20. PIN 6 Register Settings

| Signal Function | Register Bit Address | Register Definition |
|--|----------------------|---|
| PIN 6 Driver Strength Selection | <1073> | 0: 1X 1: 2X |
| Select SCL & Virtual Input 0 or PIN6 | <1074> | 0: SCL & Virtual Input 0 1: PIN6 |
| PIN 6 Pull Down Resistor Value Selection | <1076:1075> | 00: Floating 01: 10 kΩ Resistor 10: 100 kΩ Resistor 11: 1 MΩ Resistor |
| PIN 6 Mode Control | <1079:1077> | 000: Digital Input without Schmitt Trigger 001: Digital Input with Schmitt Trigger 010: Low Voltage Digital Input 011: Reserved 100: Reserved 101: Open Drain NMOS 110: Reserved 111: Reserved |

7.4.4 PIN 7 Register Settings
Table 21. PIN 7 Register Settings

| Signal Function | Register Bit Address | Register Definition |
|--|----------------------|---|
| PIN 7 (or SDA) Driver Strength Selection | <1081> | 0: 1X 1: 2X |
| Select SDA & Virtual Input 1 or PIN7 | <1082> | 0: SDA & Virtual Input 1 1: PIN7 |
| PIN 7 Pull Down Resistor Value Selection | <1084:1083> | 00: Floating 01: 10 kΩ Resistor 10: 100 kΩ Resistor 11: 1 MΩ Resistor |
| PIN7(or SDA) Mode Control | <1087:1085> | 000: Digital Input without Schmitt Trigger 001: Digital Input with Schmitt Trigger 010: Low Voltage Digital Input 011: Reserved 100: Reserved 101: Open Drain NMOS 110: Reserved 111: Reserved |

7.4.5 PIN 8 Register Settings
Table 22. PIN 8 Register Settings

| Signal Function | Register Bit Address | Register Definition |
|--|----------------------|---|
| PIN 8 4X Drive (4X, NMOS Open Drain) Selection | <1088> | 0: 4X Drive Off 1: 4X Drive On (sig_pin8_oe = 1 & reg <1095:1094> = 1x) |
| PIN 8 Pull Up/Down Resistor Selection | <1089> | 0: Pull Down Resistor 1: Pull Up Resistor |
| PIN 8 Pull Up/Down Resistor Value Selection | <1091:1090> | 00: Floating 01: 10 kΩ Resistor 10: 100 kΩ Resistor 11: 1 MΩ Resistor |
| PIN 8 Mode Control (sig_pin8_oe = 0) | <1093:1092> | 00: Digital Input without Schmitt Trigger 01: Digital Input with Schmitt Trigger 10: Low Voltage Digital Input 11: Analog Input/Output |
| PIN 8 Mode Control (sig_pin8_oe = 1) | <1095:1094> | 00: Push Pull 1X 01: Push Pull 2X 10: Open Drain NMOS 1X 11: Open Drain NMOS 2X |

7.4.6 PIN 10 Register Settings
Table 23. PIN 10 Register Settings

| Signal Function | Register Bit Address | Register Definition |
|---|----------------------|---|
| PIN 10 4X Drive (4X, NMOS Open Drain) Selection | <1096> | 0: 4X Drive Off 1: 4X Drive On (reg <1095:1094> = 1x) |
| PIN 10 Driver Strength Selection | <1097> | 0: 1X 1: 2X |
| PIN 10 Pull Up/Down Resistor Selection | <1098> | 0: Pull Down Resistor 1: Pull Up Resistor |
| PIN 10 Pull Up/Down Resistor Value Selection | <1100:1099> | 00: Floating 01: 10 kΩ Resistor 10: 100 kΩ Resistor 11: 1 MΩ Resistor |
| PIN 10 Mode Control | <1103:1101> | 000: Digital Input without Schmitt Trigger 001: Digital Input with Schmitt Trigger 010: Low Voltage Digital Input 011: Analog Input/Output 100: Push Pull 101: Open Drain NMOS 110: Open Drain PMOS 111: Analog Input & Open Drain |

7.4.7 PIN 11 Register Settings
Table 24. PIN 11 Register Settings

| Signal Function | Register Bit Address | Register Definition |
|--|----------------------|--|
| PIN 11 Pull Up/Down Resistor Selection | <1113> | 0: Pull Down Resistor 1: Pull Up Resistor |
| PIN 11 Pull Up/Down Resistor Value Selection | <1115:1114> | 00: Floating 01: 10 kΩ Resistor 10: 100 kΩ Resistor 11: 1 MΩ Resistor |
| PIN 11 Mode Control (sig_pin11_oe = 0) | <1117:1116> | 00: Digital Input without Schmitt Trigger 01: Digital Input with Schmitt Trigger 10: Low Voltage Digital Input 11: Reserved |
| PIN 11 Mode Control (sig_pin11_oe = 1) | <1119:1118> | 00: Push Pull 1X 01: Push Pull 2X 10: Reserved 11: Reserved |

7.4.8 PIN 12 Register Settings
Table 25. PIN 12 Register Settings

| Signal Function | Register Bit Address | Register Definition |
|--|----------------------|--|
| PIN 12 Pull Up/Down Resistor Selection | <1129> | 0: Pull Down Resistor 1: Pull Up Resistor |
| PIN 12 Pull Up/Down Resistor Value Selection | <1131:1130> | 00: Floating 01: 10 kΩ Resistor 10: 100 kΩ Resistor 11: 1 MΩ Resistor |
| PIN 12 Mode Control (sig_pin12_oe = 1) | <1135:1134> | 00: Push Pull 1X 01: Push Pull 2X 10: Open Drain NMOS 1X 11: Open Drain NMOS 2X |
| PIN 12 Mode Control (sig_pin12_oe = 0) | <1133:1132> | 00: Digital Input without Schmitt Trigger 01: Digital Input with Schmitt Trigger 10: Low Voltage Digital Input 11: Reserved |

7.4.9 PIN 13 Register Settings
Table 26. PIN 13 Register Settings

| Signal Function | Register Bit Address | Register Definition |
|--|----------------------|---|
| PIN 13 Driver Strength Selection | <1137> | 0: 1X 1: 2X |
| PIN 13 Pull Up/Down Resistor Selection | <1138> | 0: Pull Down Resistor 1: Pull Up Resistor |
| PIN 13 Pull Up/Down Resistor Value Selection | <1140:1139> | 00: Floating 01: 10 kΩ Resistor 10: 100 kΩ Resistor 11: 1 MΩ Resistor |
| PIN 13 Mode Control | <1143:1141> | 000: Digital Input without Schmitt Trigger 001: Digital Input with Schmitt Trigger 010: Low Voltage Digital Input 011: Reserved 100: Push Pull 101: Open Drain NMOS 110: Open Drain PMOS 111: Reserved |

7.4.10 PIN 14 Register Settings
Table 27. PIN 14 Register Settings

| Signal Function | Register Bit Address | Register Definition |
|--|----------------------|---|
| PIN 14 Driver Strength Selection | <1161> | 0: 1X 1: 2X |
| PIN 14 Pull Up/Down Resistor Selection | <1162> | 0: Pull Down Resistor 1: Pull Up Resistor |
| PIN 14 Pull Up/Down Resistor Value Selection | <1164:1163> | 00: Floating 01: 10 kΩ Resistor 10: 100 kΩ Resistor 11: 1 MΩ Resistor |
| PIN 14 Mode Control | <1167:1165> | 000: Digital Input without Schmitt Trigger 001: Digital Input with Schmitt Trigger 010: Low Voltage Digital Input 011: Reserved 100: Push Pull 101: Open Drain NMOS 110: Open Drain PMOS 111: Reserved |

7.5 GPI Structure

7.5.1 GPI Structure (for Pin 2)

Input Mode [1:0]
 00: Digital In without Schmitt Trigger, wosmt_en = 1, OE=0
 01: Digital In with Schmitt Trigger, smt_en = 1, OE = 0
 10: Low Voltage Digital In mode, lv_en = 1, OE = 0
 11: Reserved

Note 1: OE cannot be selected by user
 Note 2: OE is Matrix output, Digital In is Matrix input

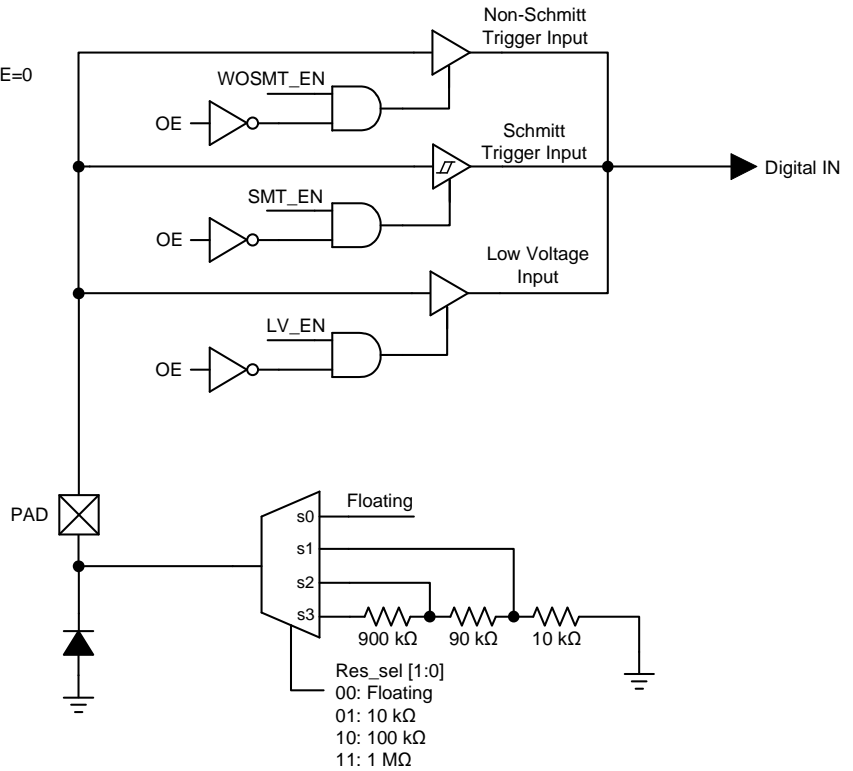

Figure 2. PIN 2 GPI Structure Diagram

7.6 Matrix OE IO Structure

7.6.1 Matrix OE IO Structure (for Pins 5, 11, 12)

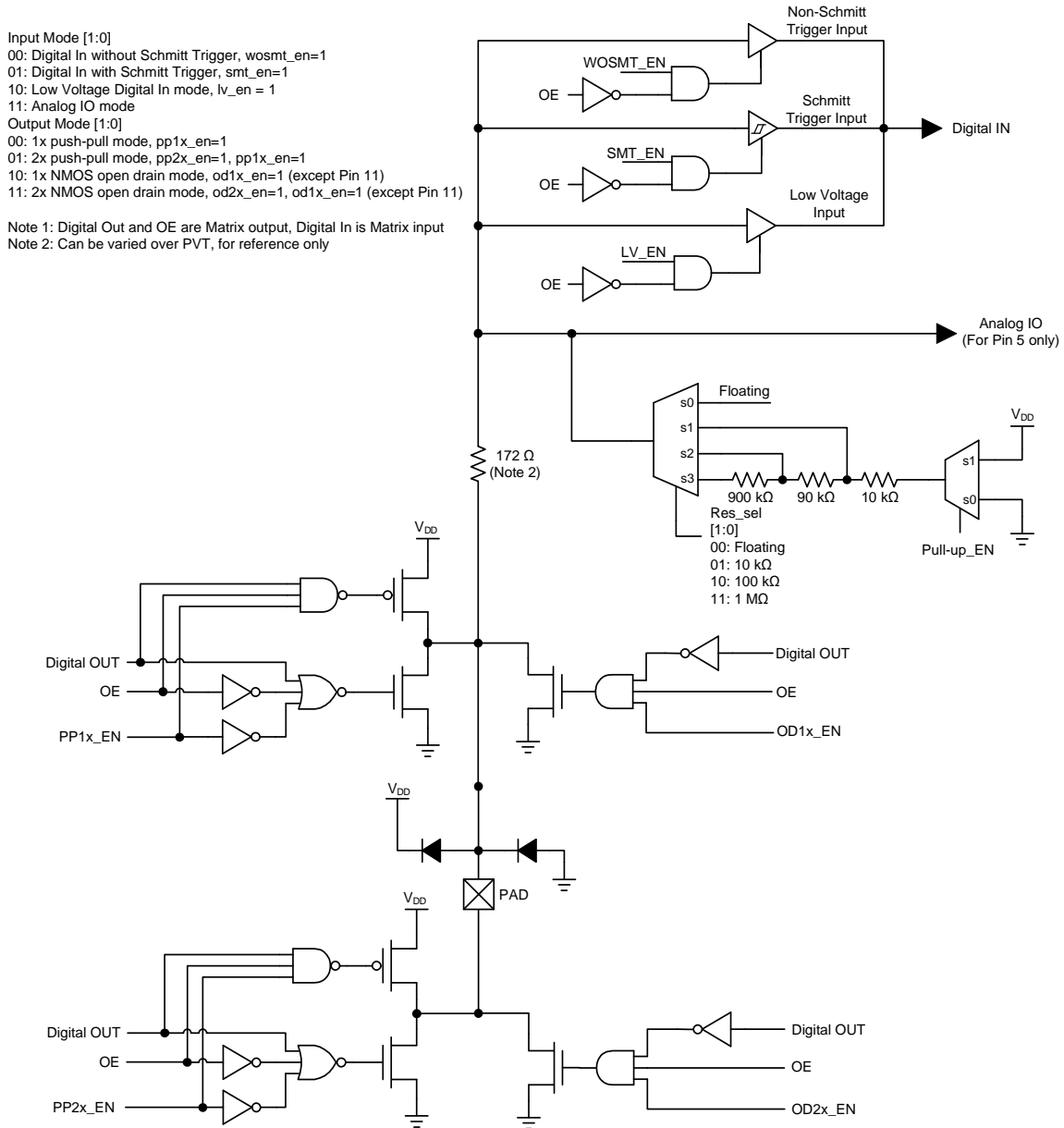

Figure 3. Matrix OE IO Structure Diagram

7.6.2 Matrix OE IO Structure (for Pins 6 and 7)

Pin 6, Pin 7 Mode [2:0]
 000: Digital Input without Schmitt Trigger
 001: Digital Input with Schmitt Trigger
 010: Low Voltage Digital Input
 011: Reserved
 100: Reserved
 101: Open Drain NMOS
 110: Reserved
 111: Reserved

Note: Digital Out and OE are Matrix output, Digital In is Matrix input

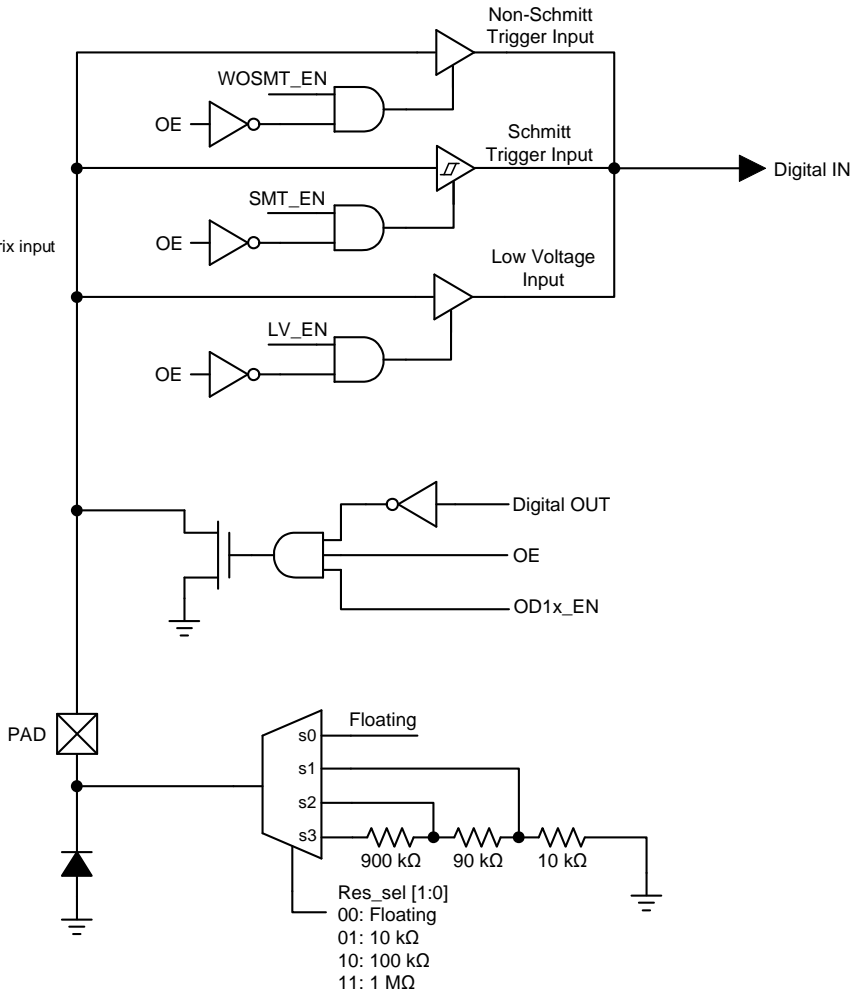

Figure 4. Matrix OE IO Structure Diagram

7.6.3 Matrix OE 4X Drive Structure (for Pin 8)

Input Mode [1:0]
 00: Digital In without Schmitt Trigger, wosmt_en=1
 01: Digital In with Schmitt Trigger, smt_en=1
 10: Low Voltage Digital In mode, lv_en = 1
 11: Analog IO mode
 Output Mode [1:0]
 00: 1x push-pull mode, pp1x_en=1
 01: 2x push-pull mode, pp2x_en=1, pp1x_en=1
 10: 1x NMOS open drain mode, od1x_en=1, odn_en=1
 11: 2x NMOS open drain mode, od2x_en=1, od1x_en=1, odn_en=1

Note 1: Digital Out and OE are Matrix output, Digital In is Matrix input
 Note 2: Can be varied over PVT, for reference only

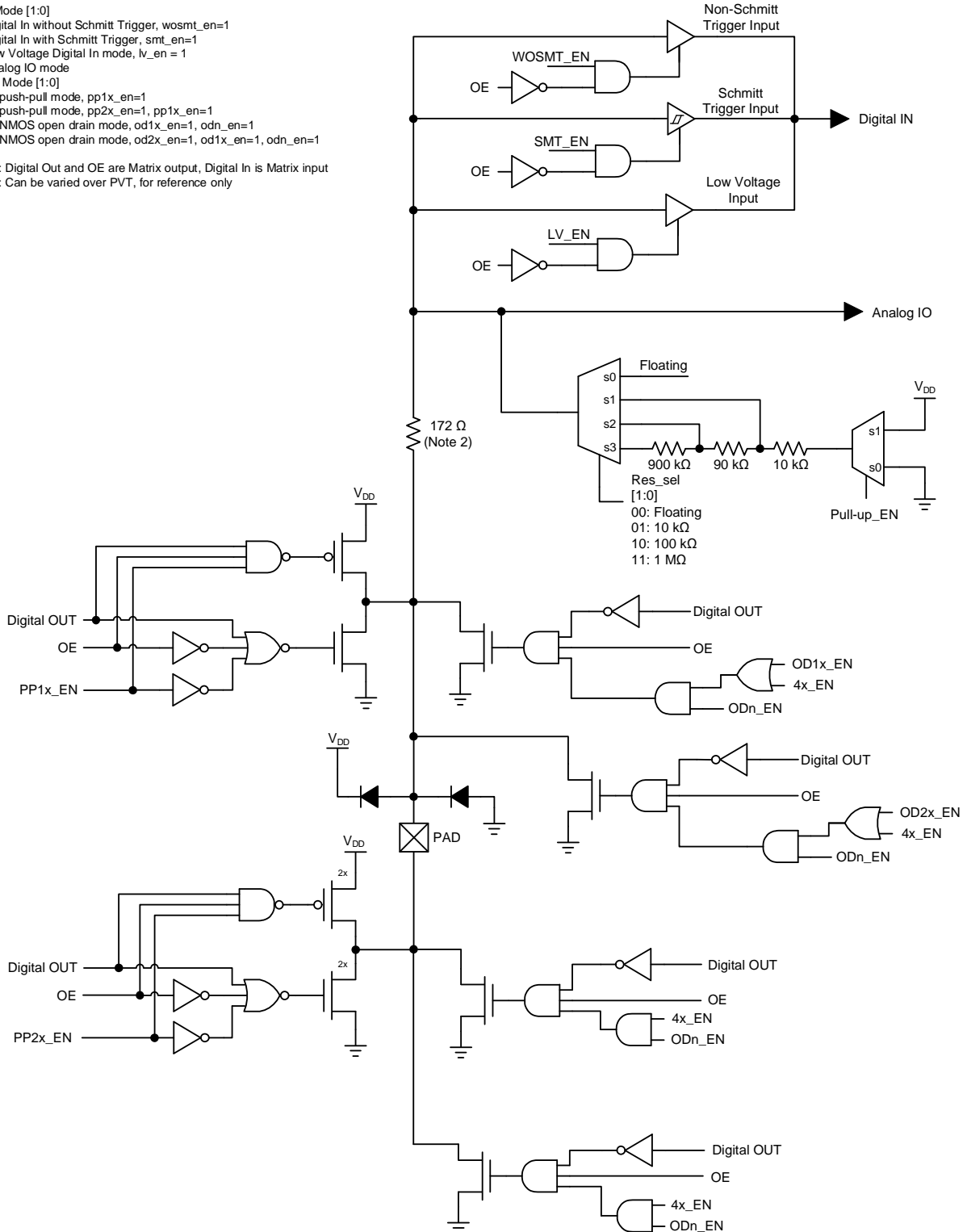

Figure 5. Matrix OE IO 4X Drive Structure Diagram

7.6.4 4X Drive Structure (for Pin 10)

Mode [2:0]
 000: Digital In without Schmitt Trigger, wosmt_en=1, OE = 0
 001: Digital In with Schmitt Trigger, smt_en=1, OE = 0
 010: Low Voltage Digital In mode, lv_en = 1, OE = 0
 011: Analog IO mode
 100: Push-pull mode, pp_en=1, OE = 1
 101: NMOS open drain mode, odn_en=1, OE = 1
 110: PMOS open drain mode, odp_en=1, OE = 1
 111: Analog IO and NMOS open-drain mode, odn_en=1 and AIO_en=1

Note 1: OE cannot be selected by user
 Note 2: Digital Out and OE are Matrix output, Digital In is Matrix input
 Note 3: Can be varied over PVT, for reference only

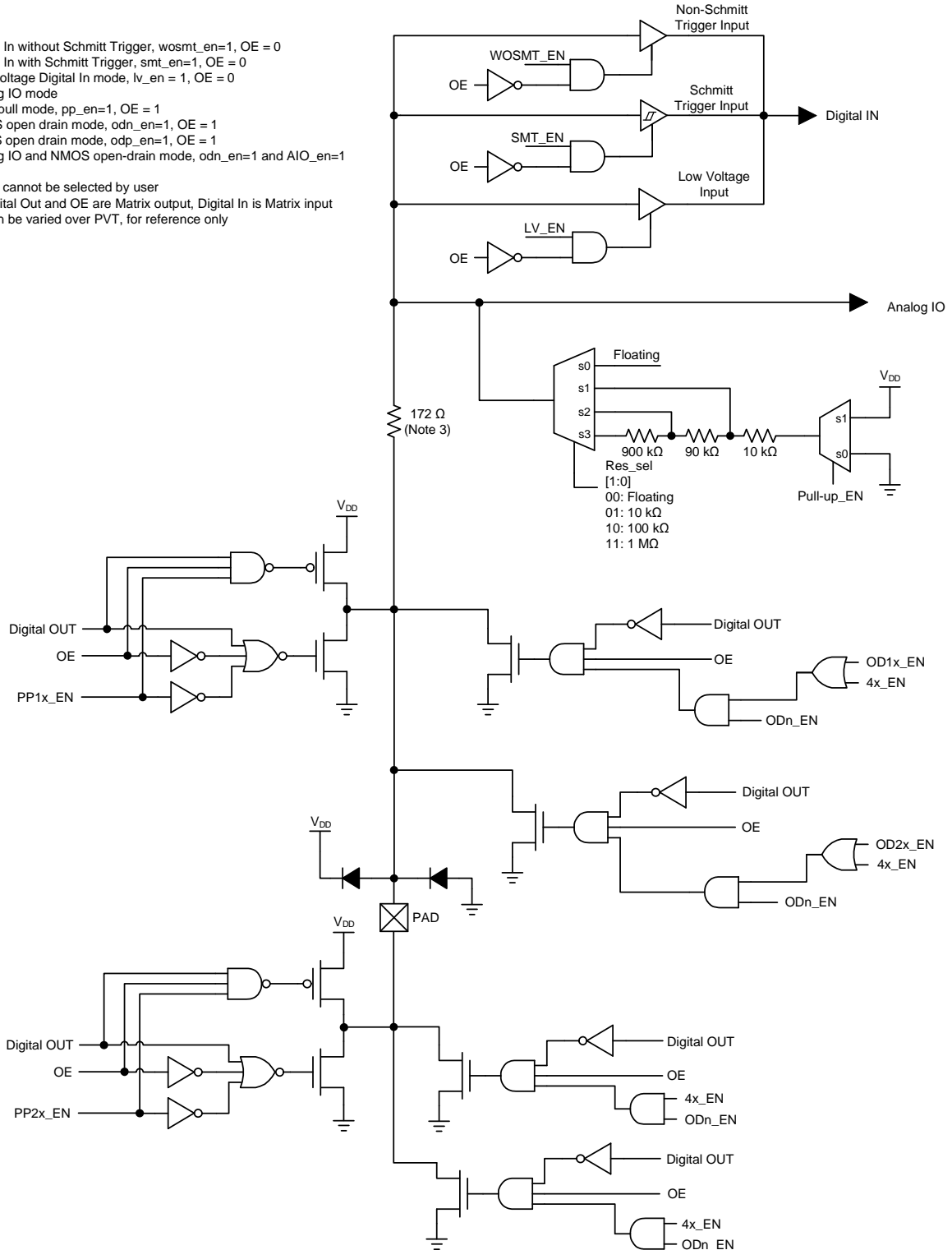

Figure 6. IO 4X Drive Structure Diagram

7.7 IO Structure

7.7.1 IO Structure (for Pins 3, 4, 13, 14)

Mode [2:0]
 000: Digital In without Schmitt Trigger, wosmt_en=1, OE = 0
 001: Digital In with Schmitt Trigger, smt_en=1, OE = 0
 010: Low Voltage Digital In mode, lv_en = 1, OE = 0
 011: Analog IO mode
 100: Push-pull mode, pp_en=1, OE = 1
 101: NMOS open drain mode, odn_en=1, OE = 1
 110: PMOS open drain mode, odp_en=1, OE = 1
 111: Analog IO and NMOS open-drain mode, odn_en=1 and AIO_en=1

Note 1: OE cannot be selected by user and is controlled by register
 Note 2: Can be varied over PVT, for reference only

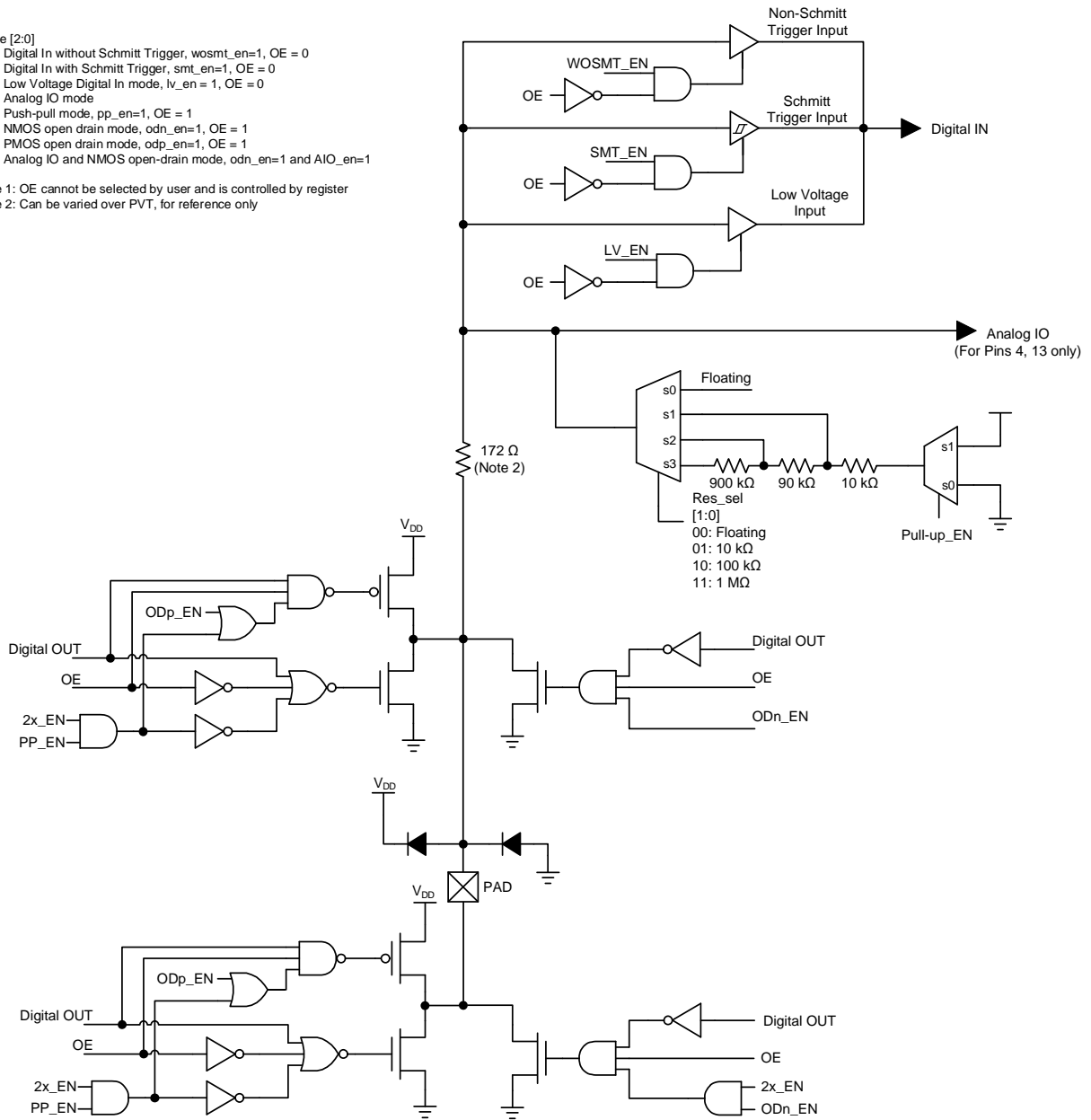

Figure 7. IO Structure Diagram

8.0 Connection Matrix

The Connection Matrix in the SLG46534 is used to create the internal routing for internal functional macrocells of the device once it is programmed. The registers are programmed from the one-time NVM cell during Test Mode Operation. The output of each functional macrocell within the SLG46534 has a specific digital bit code assigned to it that is either set to active “High” or inactive “Low” based on the design that is created. Once the 2048 register bits within the SLG46534 are programmed a fully custom circuit will be created.

The Connection Matrix has 64 inputs and 110 outputs. Each of the 64 inputs to the Connection Matrix is hard-wired to the digital output of a particular source macrocell, including IO pins, LUTs, analog comparators, other digital resources, such as V_{DD} and Ground. The input to a digital macrocell uses a 6-bit register to select one of these 64 input lines.

For a complete list of the SLG46534’s register table, see Section 21.0 Appendix A - SLG46534 Register Definition.

| Matrix Input Signal Functions | N | | | | |
|-------------------------------|------------------|----------------------------|----------------------------|----------------------------|----------------------------|
| Ground | 0 | | | | |
| Pin 2 Digital In | 1 | | | | |
| Pin 3 Digital In | 2 | | | | |
| Pin 4 Digital In | 3 | | | | |
| ⋮ | ⋮ | | | | |
| Resetb_core | 62 | | | | |
| V _{DD} | 63 | | | | |
| Matrix Inputs | N | 0 | 1 | 2 | 109 |
| | Registers | reg<5:0> | reg<13:8> | reg<21:16> | reg<877:872> |
| Matrix Outputs | Function | Matrix OUT: ASM-state0-EN0 | Matrix OUT: ASM-state0-EN1 | Matrix OUT: ASM-state0-EN2 | Matrix OUT: PD of XTAL Osc |

Figure 8. Connection Matrix

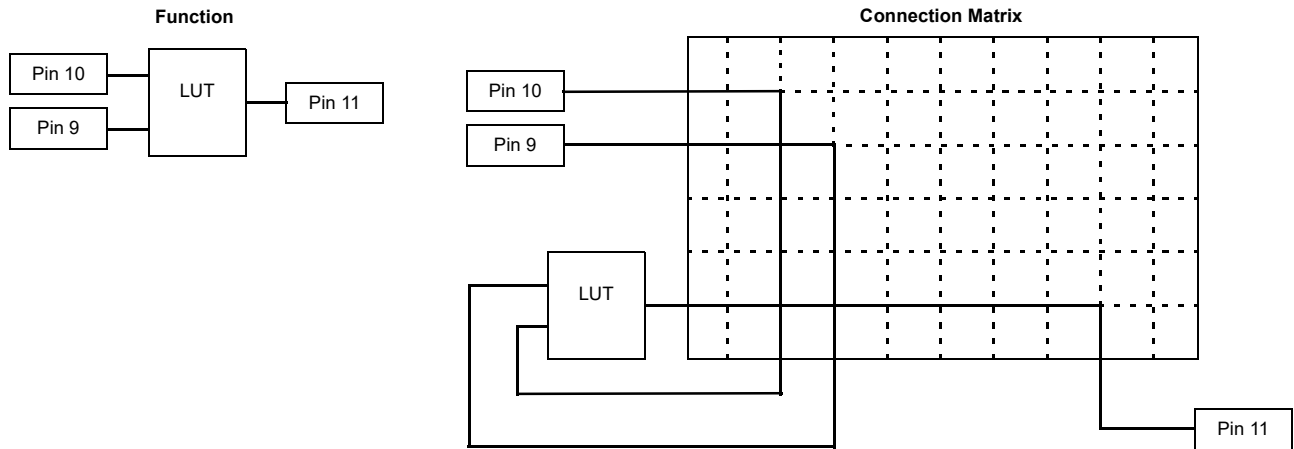

Figure 9. Connection Matrix Example

8.1 Matrix Input Table
Table 28. Matrix Input Table

| Matrix Input Number | Matrix Input Signal Function | Matrix Decode | | | | | |
|---------------------|---|---------------|---|---|---|---|---|
| | | 5 | 4 | 3 | 2 | 1 | 0 |
| 0 | Ground | 0 | 0 | 0 | 0 | 0 | 0 |
| 1 | Pin2 Digital Input | 0 | 0 | 0 | 0 | 0 | 1 |
| 2 | Reserved | 0 | 0 | 0 | 0 | 1 | 0 |
| 3 | Pin3 Digital Input | 0 | 0 | 0 | 0 | 1 | 1 |
| 4 | Reserved | 0 | 0 | 0 | 1 | 0 | 0 |
| 5 | Pin4 Digital Input | 0 | 0 | 0 | 1 | 0 | 1 |
| 6 | Pin5 Digital Input | 0 | 0 | 0 | 1 | 1 | 0 |
| 7 | Pin8 Digital Input | 0 | 0 | 0 | 1 | 1 | 1 |
| 8 | LUT2_0 / DFF0 Output | 0 | 0 | 1 | 0 | 0 | 0 |
| 9 | LUT2_1 / DFF1 Output | 0 | 0 | 1 | 0 | 0 | 1 |
| 10 | LUT2_2 / DFF2 Output | 0 | 0 | 1 | 0 | 1 | 0 |
| 11 | LUT2_3 / PGEN Output | 0 | 0 | 1 | 0 | 1 | 1 |
| 12 | LUT3_0 / DFF3 Output | 0 | 0 | 1 | 1 | 0 | 0 |
| 13 | LUT3_1 / DFF4 Output | 0 | 0 | 1 | 1 | 0 | 1 |
| 14 | LUT3_2 / DFF5 Output | 0 | 0 | 1 | 1 | 1 | 0 |
| 15 | LUT3_3 / DFF6 Output | 0 | 0 | 1 | 1 | 1 | 1 |
| 16 | LUT3_4 / DFF7 Output | 0 | 1 | 0 | 0 | 0 | 0 |
| 17 | LUT3_5 / CNT_DLY2(8bit) Output | 0 | 1 | 0 | 0 | 0 | 1 |
| 18 | LUT3_6 / CNT_DLY3(8bit) Output | 0 | 1 | 0 | 0 | 1 | 0 |
| 19 | LUT3_7 / CNT_DLY4(8bit) Output | 0 | 1 | 0 | 0 | 1 | 1 |
| 20 | LUT3_8 / CNT_DLY5(8bit) Output | 0 | 1 | 0 | 1 | 0 | 0 |
| 21 | LUT3_9 / CNT_DLY6(8bit) Output | 0 | 1 | 0 | 1 | 0 | 1 |
| 22 | LUT4_0 / CNT_DLY0(16bit) Output | 0 | 1 | 0 | 1 | 1 | 0 |
| 23 | LUT4_1 / CNT_DLY1(16bit) Output | 0 | 1 | 0 | 1 | 1 | 1 |
| 24 | LUT3_10 / Pipe Delay (1st stage) Output | 0 | 1 | 1 | 0 | 0 | 0 |
| 25 | Pipe Delay Output0 | 0 | 1 | 1 | 0 | 0 | 1 |
| 26 | Pipe Delay Output1 | 0 | 1 | 1 | 0 | 1 | 0 |
| 27 | Internal OSC Pre-Divided by 1/2/4/8 Output and Post-Divided by 1/2/3/4/8/12/24/64 Output (25KHz/2MHz) | 0 | 1 | 1 | 0 | 1 | 1 |
| 28 | Internal OSC Pre-Divided by 1/2/4/8 Output and Post-Divided by 1/2/3/4/8/12/24/64 Output (25KHz/2MHz) | 0 | 1 | 1 | 1 | 0 | 0 |
| 29 | Internal OSC Pre-Divided by 1/2/4/8 Output (25MHz) | 0 | 1 | 1 | 1 | 0 | 1 |
| 30 | Filter0 / Edge Detect0 Output | 0 | 1 | 1 | 1 | 1 | 0 |
| 31 | Filter1 / Edge Detect1 Output | 0 | 1 | 1 | 1 | 1 | 1 |
| 32 | Pin6 Digital or I2C_virtual_0 Input | 1 | 0 | 0 | 0 | 0 | 0 |
| 33 | Pin7 Digital or I2C_virtual_1 Input | 1 | 0 | 0 | 0 | 0 | 1 |
| 34 | I2C_virtual_2 Input | 1 | 0 | 0 | 0 | 1 | 0 |
| 35 | I2C_virtual_3 Input | 1 | 0 | 0 | 0 | 1 | 1 |

Table 28. Matrix Input Table

| Matrix Input Number | Matrix Input Signal Function | Matrix Decode | | | | | |
|---------------------|--|---------------|---|---|---|---|---|
| | | 5 | 4 | 3 | 2 | 1 | 0 |
| 36 | I2C_virtual_4 Input | 1 | 0 | 0 | 1 | 0 | 0 |
| 37 | I2C_virtual_5 Input | 1 | 0 | 0 | 1 | 0 | 1 |
| 38 | I2C_virtual_6 Input | 1 | 0 | 0 | 1 | 1 | 0 |
| 39 | I2C_virtual_7 Input | 1 | 0 | 0 | 1 | 1 | 1 |
| 40 | ASM-stateX-dout0 | 1 | 0 | 1 | 0 | 0 | 0 |
| 41 | ASM-stateX-dout1 | 1 | 0 | 1 | 0 | 0 | 1 |
| 42 | ASM-stateX-dout2 | 1 | 0 | 1 | 0 | 1 | 0 |
| 43 | ASM-stateX-dout3 | 1 | 0 | 1 | 0 | 1 | 1 |
| 44 | ASM-stateX-dout4 | 1 | 0 | 1 | 1 | 0 | 0 |
| 45 | ASM-stateX-dout5 | 1 | 0 | 1 | 1 | 0 | 1 |
| 46 | ASM-stateX-dout6 | 1 | 0 | 1 | 1 | 1 | 0 |
| 47 | ASM-stateX-dout7 | 1 | 0 | 1 | 1 | 1 | 1 |
| 48 | Pin10 Digital Input | 1 | 1 | 0 | 0 | 0 | 0 |
| 49 | Reserved | 1 | 1 | 0 | 0 | 0 | 1 |
| 50 | Pin11 Digital Input | 1 | 1 | 0 | 0 | 1 | 0 |
| 51 | Reserved | 1 | 1 | 0 | 0 | 1 | 1 |
| 52 | Pin12 Digital Input | 1 | 1 | 0 | 1 | 0 | 0 |
| 53 | Pin13 Digital Input | 1 | 1 | 0 | 1 | 0 | 1 |
| 54 | Reserved | 1 | 1 | 0 | 1 | 1 | 0 |
| 55 | Reserved | 1 | 1 | 0 | 1 | 1 | 1 |
| 56 | Pin14 Digital Input | 1 | 1 | 1 | 0 | 0 | 0 |
| 57 | ACMP_0 Output | 1 | 1 | 1 | 0 | 0 | 1 |
| 58 | ACMP_1 Output | 1 | 1 | 1 | 0 | 1 | 0 |
| 59 | ACMP_2 Output | 1 | 1 | 1 | 0 | 1 | 1 |
| 60 | Reserved | 1 | 1 | 1 | 1 | 0 | 0 |
| 61 | Programmable Delay with Edge Detector Output | 1 | 1 | 1 | 1 | 0 | 1 |
| 62 | nRST_core (POR) as matrix input | 1 | 1 | 1 | 1 | 1 | 0 |
| 63 | V _{DD} | 1 | 1 | 1 | 1 | 1 | 1 |

8.2 Matrix Output Table
Table 29. Matrix Output Table

| Register Bit Address | Matrix Output Signal Function Note: For each Address, the two most significant bits are unused) | Matrix Output Number |
|----------------------|--|----------------------|
| reg <7:0> | Matrix OUT: ASM-state0-EN0 | 0 |
| reg <15:8> | Matrix OUT: ASM-state0-EN1 | 1 |
| reg <23:16> | Matrix OUT: ASM-state0-EN2 | 2 |
| reg <31:24> | Matrix OUT: ASM-state1-EN0 | 3 |
| reg <39:32> | Matrix OUT: ASM-state1-EN1 | 4 |
| reg <47:40> | Matrix OUT: ASM-state1-EN2 | 5 |
| reg <55:48> | Matrix OUT: ASM-state2-EN0 | 6 |
| reg <63:56> | Matrix OUT: ASM-state2-EN1 | 7 |
| reg <71:64> | Matrix OUT: ASM-state2-EN2 | 8 |
| reg <79:72> | Matrix OUT: ASM-state3-EN0 | 9 |
| reg <87:80> | Matrix OUT: ASM-state3-EN1 | 10 |
| reg <95:88> | Matrix OUT: ASM-state3-EN2 | 11 |
| reg <103:96> | Matrix OUT: ASM-state4-EN0 | 12 |
| reg <111:104> | Matrix OUT: ASM-state4-EN1 | 13 |
| reg <119:112> | Matrix OUT: ASM-state4-EN2 | 14 |
| reg <127:120> | Matrix OUT: ASM-state5-EN0 | 15 |
| reg <135:128> | Matrix OUT: ASM-state5-EN1 | 16 |
| reg <143:136> | Matrix OUT: ASM-state5-EN2 | 17 |
| reg <151:144> | Matrix OUT: ASM-state6-EN0 | 18 |
| reg <159:152> | Matrix OUT: ASM-state6-EN1 | 19 |
| reg <167:160> | Matrix OUT: ASM-state6-EN2 | 20 |
| reg <175:168> | Matrix OUT: ASM-state7-EN0 | 21 |
| reg <183:176> | Matrix OUT: ASM-state7-EN1 | 22 |
| reg <191:184> | Matrix OUT: ASM-state7-EN2 | 23 |
| reg <199:192> | Matrix OUT: ASM-state-nRST | 24 |
| reg <207:200> | Reserved | 25 |
| reg <215:208> | Reserved | 26 |
| reg <223:216> | Matrix OUT: PIN3 Digital Output Source | 27 |
| reg <231:224> | Reserved | 28 |
| reg <239:232> | Reserved | 29 |
| reg <247:240> | Matrix OUT: PIN4 Digital Output Source | 30 |
| reg <255:248> | Matrix OUT: PIN5 Digital Output Source | 31 |
| reg <263:256> | Matrix OUT: PIN5 Output Enable | 32 |
| reg <271:264> | Matrix OUT: PIN6 Digital Output Source (SCL with VI/Input & NMOS open-drain) | 33 |
| reg <279:272> | Matrix OUT: PIN7 Digital Output Source (SDA with VI/Input & NMOS open-drain) | 34 |

Table 29. Matrix Output Table

| Register Bit Address | Matrix Output Signal Function Note: For each Address, the two most significant bits are unused) | Matrix Output Number |
|----------------------|--|----------------------|
| reg <287:280> | Matrix OUT: PIN8 Digital Output Source | 35 |
| reg <295:288> | Matrix OUT: PIN8 Output Enable | 36 |
| reg <303:296> | Matrix OUT: PIN10 Digital Output Source | 37 |
| reg <311:304> | Reserved | 38 |
| reg <319:312> | Reserved | 39 |
| reg <327:320> | Matrix OUT: PIN11 Digital Output Source | 40 |
| reg <335:328> | Matrix OUT: PIN11 Output Enable | 41 |
| reg <343:336> | Reserved | 42 |
| reg <351:344> | Matrix OUT: PIN12 Digital Output Source | 43 |
| reg <359:352> | Matrix OUT: PIN12 Output Enable | 44 |
| reg <367:360> | Matrix OUT: PIN13 Digital Output Source | 45 |
| reg <375:368> | Reserved | 46 |
| reg <383:376> | Reserved | 47 |
| reg <391:384> | Reserved | 48 |
| reg <399:392> | Reserved | 49 |
| reg <407:400> | Matrix OUT: PIN14 Digital Output Source | 50 |
| reg <415:408> | Matrix OUT: ACMP0 PDB (Power Down) | 51 |
| reg <423:416> | Matrix OUT: ACMP1 PDB (Power Down) | 52 |
| reg <431:424> | Matrix OUT: ACMP2 PDB (Power Down) | 53 |
| reg <439:432> | Reserved | 54 |
| reg <447:440> | Matrix OUT: Input of Filter_0 with fixed time edge detector | 55 |
| reg <455:448> | Matrix OUT: Input of Filter_1 with fixed time edge detector | 56 |
| reg <463:456> | Matrix OUT: Input of Programmable Delay & Edge Detector | 57 |
| reg <471:464> | Matrix OUT: OSC 25KHz/2MHz PDB (Power Down) | 58 |
| reg <479:472> | Matrix OUT: OSC 25MHz PDB (Power Down) | 59 |
| reg <487:480> | Matrix OUT: IN0 of LUT2_0 or Clock Input of DFF0 | 60 |
| reg <495:488> | Matrix OUT: IN1 of LUT2_0 or Data Input of DFF0 | 61 |
| reg <503:496> | Matrix OUT: IN0 of LUT2_1 or Clock Input of DFF1 | 62 |
| reg <511:504> | Matrix OUT: IN1 of LUT2_1 or Data Input of DFF1 | 63 |
| reg <519:512> | Matrix OUT: IN0 of LUT2_2 or Clock Input of DFF2 | 64 |
| reg <527:520> | Matrix OUT: IN1 of LUT2_2 or Data Input of DFF2 | 65 |
| reg <535:528> | Matrix OUT: IN0 of LUT2_3 or Clock Input of PGEN | 66 |
| reg <543:536> | Matrix OUT: IN1 of LUT2_3 or RSTB of PGEN | 67 |
| reg <551:544> | Matrix OUT: IN0 of LUT3_0 or Clock Input of DFF3 | 68 |

Table 29. Matrix Output Table

| Register Bit Address | Matrix Output Signal Function Note: For each Address, the two most significant bits are unused) | Matrix Output Number |
|----------------------|--|----------------------|
| reg <559:552> | Matrix OUT: IN1 of LUT3_0 or Data Input of DFF3 | 69 |
| reg <567:560> | Matrix OUT: IN2 of LUT3_0 or RSTB (SETB) of DFF3 | 70 |
| reg <575:568> | Matrix OUT: IN0 of LUT3_1 or Clock Input of DFF4 | 71 |
| reg <583:576> | Matrix OUT: IN1 of LUT3_1 or Data Input of DFF4 | 72 |
| reg <591:584> | Matrix OUT: IN2 of LUT3_1 or RSTB (SETB) of DFF4 | 73 |
| reg <599:592> | Matrix OUT: IN0 of LUT3_2 or Clock Input of DFF5 | 74 |
| reg <607:600> | Matrix OUT: IN1 of LUT3_2 or Data Input of DFF5 | 75 |
| reg <615:608> | Matrix OUT: IN2 of LUT3_2 or RSTB (SETB) of DFF5 | 76 |
| reg <623:616> | Matrix OUT: IN0 of LUT3_3 or Clock Input of DFF6 | 77 |
| reg <631:624> | Matrix OUT: IN1 of LUT3_3 or Data Input of DFF6 | 78 |
| reg <639:632> | Matrix OUT: IN2 of LUT3_3 or RSTB (SETB) of DFF6 | 79 |
| reg <647:640> | Matrix OUT: IN0 of LUT3_4 or Clock Input of DFF7 | 80 |
| reg <655:648> | Matrix OUT: IN1 of LUT3_4 or Data Input of DFF7 | 81 |
| reg <663:656> | Matrix OUT: IN2 of LUT3_4 or RSTB (SETB) of DFF7 | 82 |
| reg <671:664> | Matrix OUT: IN0 of LUT3_5 or Delay2 Input (or Counter2 RST Input) | 83 |
| reg <679:672> | Matrix OUT: IN1 of LUT3_5 or External Clock Input of Delay2 (or Counter2) | 84 |
| reg <687:680> | Matrix OUT: IN2 of LUT3_5 | 85 |
| reg <695:688> | Matrix OUT: IN0 of LUT3_6 or Delay3 Input (or Counter3 RST Input) | 86 |
| reg <703:696> | Matrix OUT: IN1 of LUT3_6 or External Clock Input of Delay3 (or Counter3) | 87 |
| reg <711:704> | Matrix OUT: IN2 of LUT3_6 | 88 |
| reg <719:712> | Matrix OUT: IN0 of LUT3_7 or Delay4 Input (or Counter4 RST Input) | 89 |
| reg <727:720> | Matrix OUT: IN1 of LUT3_7 or External Clock Input of Delay4 (or Counter4) | 90 |
| reg <735:728> | Matrix OUT: IN2 of LUT3_7 | 91 |
| reg <743:736> | Matrix OUT: IN0 of LUT3_8 or Delay5 Input (or Counter5 RST Input) | 92 |
| reg <751:744> | Matrix OUT: IN1 of LUT3_8 or External Clock Input of Delay5 (or Counter5) | 93 |
| reg <759:752> | Matrix OUT: IN2 of LUT3_8 | 94 |
| reg <767:760> | Matrix OUT: IN0 of LUT3_9 or Delay6 Input (or Counter6 RST Input) | 95 |
| reg <775:768> | Matrix OUT: IN1 of LUT3_9 or External Clock Input of Delay6 (or Counter6) | 96 |
| reg <783:776> | Matrix OUT: IN2 of LUT3_9 | 97 |
| reg <791:784> | Matrix OUT: IN0 of LUT3_10 or Input of Pipe Delay | 98 |
| reg <799:792> | Matrix OUT: IN1 of LUT3_10 or RSTB of Pipe Delay | 99 |
| reg <807:800> | Matrix OUT: IN2 of LUT3_10 or Clock of Pipe Delay | 100 |
| reg <815:808> | Matrix OUT: IN0 of LUT4_0 or Delay0 Input (or Counter0 RST/SET Input) | 101 |
| reg <823:816> | Matrix OUT: IN1 of LUT4_0 or External Clock Input of Delay0 (or Counter0) | 102 |
| reg <831:824> | Matrix OUT: IN2 of LUT4_0 or UP Input of FSM0 | 103 |
| reg <839:832> | Matrix OUT: IN3 of LUT4_0 or KEEP Input of FSM0 | 104 |
| reg <847:840> | Matrix OUT: IN0 of LUT4_1 or Delay1 Input (or Counter1 RST/SET Input) | 105 |
| reg <855:848> | Matrix OUT: IN1 of LUT4_1 or External Clock Input of Delay1 (or Counter1) | 106 |
| reg <863:856> | Matrix OUT: IN2 of LUT4_1 or UP Input of FSM1 | 107 |

Table 29. Matrix Output Table

| Register Bit Address | Matrix Output Signal Function Note: For each Address, the two most significant bits are unused) | Matrix Output Number |
|----------------------|--|----------------------|
| reg <871:864> | Matrix OUT: IN3 of LUT4_1 or KEEP Input of FSM1 | 108 |
| reg <879:872> | Matrix OUT: PD of crystal oscillator by reg<1268> | 109 |

8.3 Connection Matrix Virtual Inputs

As mentioned previously, the Connection Matrix inputs come from the outputs of various digital macrocells on the device. Eight of the Connection Matrix inputs have the special characteristic that the state of these signal lines comes from a corresponding data bit written as a register value via I²C. This gives the user the ability to write data via the serial channel, and have this information translated into signals that can be driven into the Connection Matrix and from the Connection Matrix to the digital inputs of other macrocells on the device. The I²C address for reading and writing these register values is at byte 0244.

Six of the eight Connection Matrix Virtual Inputs are dedicated to this virtual input function. An I²C write command to these register bits will set the signal values going into the Connection Matrix to the desired state. A read command to these register bits will read either the original data values coming from the NVM memory bits (that were loaded during the initial device startup), or the values from a previous write command (if that has happened).

Two of the eight Connection Matrix Virtual Inputs are shared with Pin digital inputs, (Pin6 Digital or I2C_virtual_0 Input) and (Pin7 Digital or I2C_virtual_1 Input). If the virtual input mode is selected, an I²C write command to these register bits will set the signal values going into the Connection Matrix to the desired state. A read command to these register bits will read either the original data values coming from the NVM memory bits (that were loaded during the initial device startup), or the values from a previous write command (if that has happened). Two register bits select whether the Connection Matrix input comes from the pin input or from the virtual register:

- reg <1074> Select SCL & Virtual Input 0 or PIN6
- reg <1082> Select SDA & Virtual Input 1 or PIN7

See table below for Connection Matrix Virtual Inputs.

| Matrix Input Number | Matrix Input Signal Function | Register Bit Addresses (d) |
|---------------------|------------------------------|----------------------------|
| 32 | I2C_virtual_0 Input | reg<1952> |
| 33 | I2C_virtual_1 Input | reg<1953> |
| 34 | I2C_virtual_2 Input | reg<1954> |
| 35 | I2C_virtual_3 Input | reg<1955> |
| 36 | I2C_virtual_4 Input | reg<1956> |
| 37 | I2C_virtual_5 Input | reg<1957> |
| 38 | I2C_virtual_6 Input | reg<1958> |
| 39 | I2C_virtual_7 Input | reg<1959> |

8.4 Connection Matrix Virtual Outputs

The digital outputs of the various macrocells are routed to the Connection Matrix to enable interconnections to the inputs of other macrocells in the device. At the same time, it is possible to read the state of each of the macrocell outputs as a register value via I²C. This option, called Connection Matrix Virtual Outputs, allows the user to remotely read the values of each macrocell output. The I²C addresses for reading these register values are at bytes 0240 to 0247. Write commands to these same register values will be ignored (with the exception of the Virtual Input register bits at byte 0244).

9.0 Combination Function Macrocells

The SLG46534 has seventeen combination function macrocells that can serve more than one logic or timing function. In each case, they can serve as a Look Up Table (LUT), or as another logic or timing function. See the list below for the functions that can be implemented in these macrocells:

- Three macrocells that can serve as either 2-bit LUTs or as D Flip Flops;
- Five macrocells that can serve as either 3-bit LUTs or as D Flip Flops with Set/Reset Input;
- One macrocell that can serve as either 3-bit LUT or as Pipe Delay;
- One macrocell that can serve as either 2-bit LUT or as Programmable Pattern Generator (PGEN);
- Five macrocells that can serve as either 3-bit LUTs or as 8-Bit Counter / Delays;
- Two macrocells that can serve as either 4-bit LUTs or as 16-Bit Counter / Delays.

Inputs/Outputs for the 17 combination function macrocells are configured from the connection matrix with specific logic functions being defined by the state of NVM bits.

When used as a LUT to implement combinatorial logic functions, the outputs of the LUTs can be configured to any user defined function, including the following standard digital logic devices (AND, NAND, OR, NOR, XOR, XNOR).

9.1 2-Bit LUT or D Flip Flop Macrocells

There are three macrocells that can serve as either 2-bit LUTs or as D Flip Flops. When used to implement LUT functions, the 2-bit LUTs each take in two input signals from the connection matrix and produce a single output, which goes back into the connection matrix. When used to implement D Flip Flop function, the two input signals from the connection matrix go to the data (D) and clock (clk) inputs for the Flip Flop, with the output going back to the connection matrix.

The operation of the D Flip-Flop and Latch will follow the functional descriptions below:

DFF: CLK is rising edge triggered, then Q = D; otherwise Q will not change.

Latch: when CLK is Low, then Q = D; otherwise Q remains its previous value (input D has no effect on the output, when CLK is High)

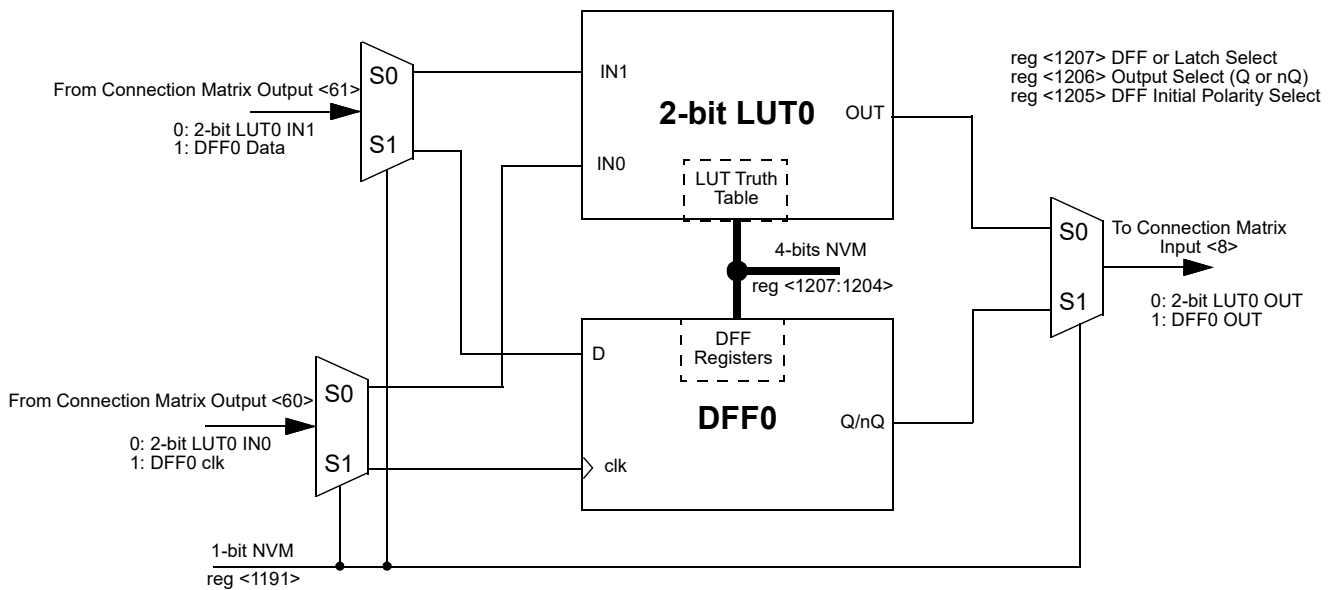

Figure 10. 2-bit LUT0 or DFF0

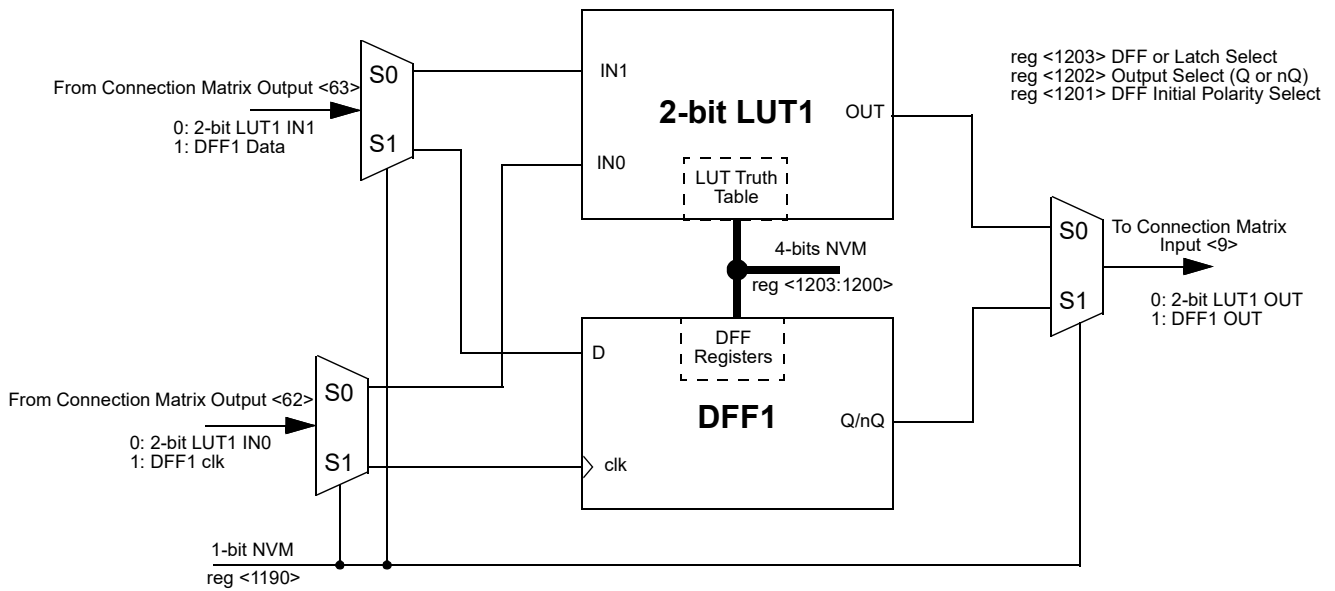

Figure 11. 2-bit LUT1 or DFF1

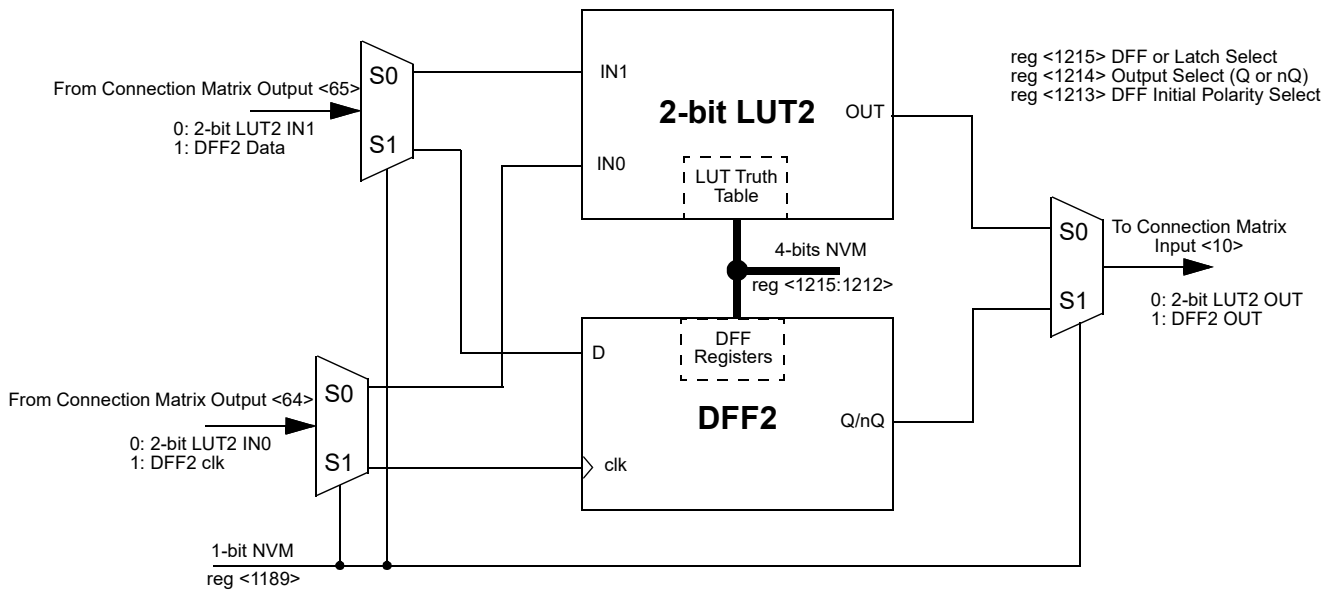

Figure 12. 2-bit LUT2 or DFF2

9.1.1 2-Bit LUT or D Flip Flop Macrocells Used as 2-Bit LUTs

Table 30. 2-bit LUT0 Truth Table

| IN1 | IN0 | OUT | |
|-----|-----|------------|-----|
| 0 | 0 | reg <1204> | LSB |
| 0 | 1 | reg <1205> | |
| 1 | 0 | reg <1206> | |
| 1 | 1 | reg <1207> | MSB |

Table 32. 2-bit LUT2 Truth Table

| IN1 | IN0 | OUT | |
|-----|-----|------------|-----|
| 0 | 0 | reg <1212> | LSB |
| 0 | 1 | reg <1213> | |
| 1 | 0 | reg <1214> | |
| 1 | 1 | reg <1215> | MSB |

Table 31. 2-bit LUT1 Truth Table

| IN1 | IN0 | OUT | |
|-----|-----|------------|-----|
| 0 | 0 | reg <1200> | LSB |
| 0 | 1 | reg <1201> | |
| 1 | 0 | reg <1202> | |
| 1 | 1 | reg <1203> | MSB |

Each Macrocell, when programmed for a LUT function, uses a 4-bit register to define their output function:

2-Bit LUT0 is defined by reg<1207:1204>

2-Bit LUT1 is defined by reg<1203:1200>

2-Bit LUT2 is defined by reg<1215:1212>

The table below shows the register bits for the standard digital logic devices (AND, NAND, OR, NOR, XOR, XNOR) that can be created within each of the two 2-bit LUT logic cells.

Table 33. 2-bit LUT Standard Digital Functions

| Function | MSB | | | LSB |
|----------|-----|---|---|-----|
| AND-2 | 1 | 0 | 0 | 0 |
| NAND-2 | 0 | 1 | 1 | 1 |
| OR-2 | 1 | 1 | 1 | 0 |
| NOR-2 | 0 | 0 | 0 | 1 |
| XOR-2 | 0 | 1 | 1 | 0 |
| XNOR-2 | 1 | 0 | 0 | 1 |

9.1.2 2-Bit LUT or D Flip Flop Macrocells Used as D Flip Flop Register Settings
Table 34. DFF0 Register Settings

| Signal Function | Register Bit Address | Register Definition |
|------------------------------|----------------------|--------------------------------------|
| LUT2_0 or DFF0 Select | <1191> | 0: LUT2_0 1: DFF0 |
| DFF0 Initial Polarity Select | <1205> | 0: Low 1: High |
| DFF0 Output Select | <1206> | 0: Q output 1: nQ output |
| DFF0 or Latch Select | <1207> | 0: DFF function 1: Latch function |

Table 35. DFF1 Register Settings

| Signal Function | Register Bit Address | Register Definition |
|------------------------------|----------------------|--------------------------------------|
| LUT2_1 or DFF1 Select | <1190> | 0: LUT2_1 1: DFF1 |
| DFF1 Initial Polarity Select | <1201> | 0: Low 1: High |
| DFF1 Output Select | <1202> | 0: Q output 1: nQ output |
| Select or Latch select | <1203> | 0: DFF function 1: Latch function |

Table 36. DFF2 Register Settings

| Signal Function | Register Bit Address | Register Definition |
|------------------------------|----------------------|--------------------------------------|
| LUT2_2 or DFF2 Select | <1189> | 0: LUT2_2 1: DFF2 |
| DFF2 Initial Polarity Select | <1213> | 0: Low 1: High |
| DFF2 Output Select | <1214> | 0: Q output 1: nQ output |
| DFF2 or Latch Select | <1215> | 0: DFF function 1: Latch function |

9.2 Initial Polarity Operations

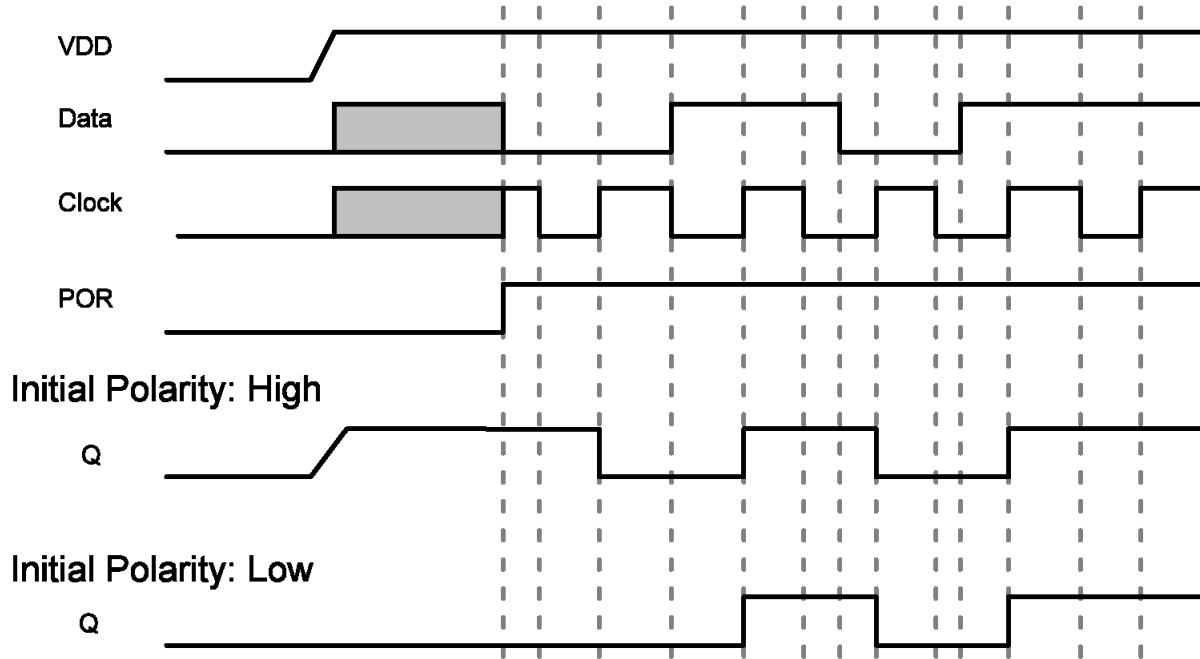

Figure 13. DFF Polarity Operations

9.3 3-Bit LUT or D Flip Flop with Set/Reset Macrocells

There are five macrocells that can serve as either 3-bit LUTs or as D Flip Flops with Set/Reset inputs. When used to implement LUT functions, the 3-bit LUTs each take in three input signals from the connection matrix and produce a single output, which goes back into the connection matrix. When used to implement D Flip Flop function, the three input signals from the connection matrix go to the data (D) and clock (clk) and Set/Reset (nRST/nSET) inputs for the Flip Flop, with the output going back to the connection matrix.

DFF3 has a user selectable option to allow the macrocell output to either come from the Q/nQ output of one D Flip Flop, or two D Flip Flops in series, with the first D Flip Flop triggering on the rising clock edge, and the second D Flip Flop triggering on the falling clock edge.

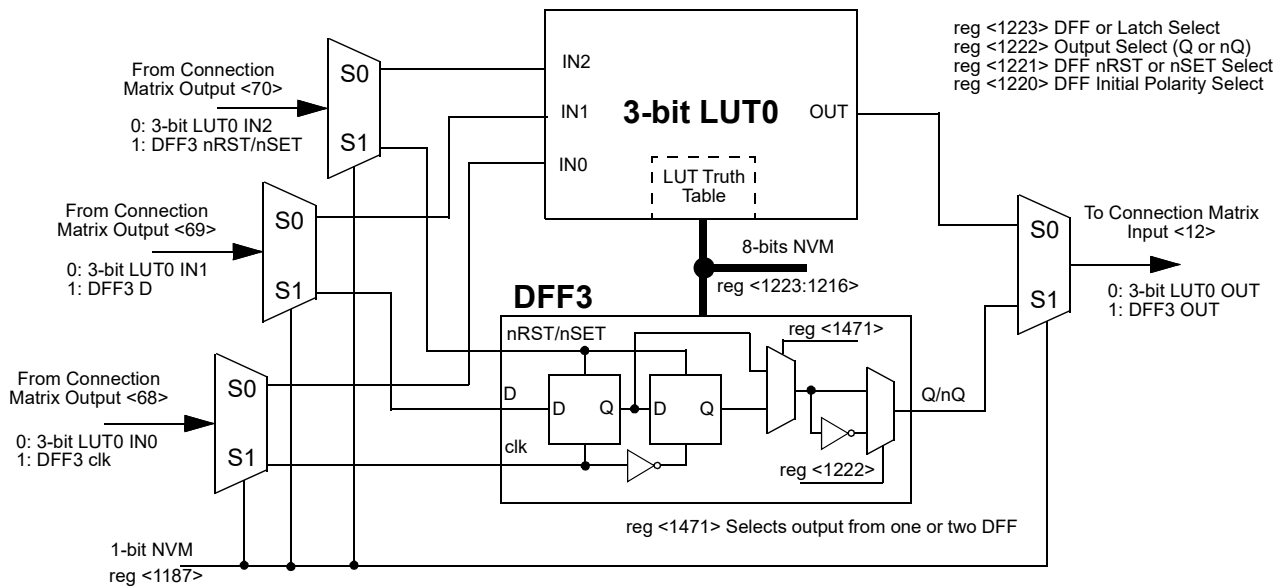

Figure 14. 3-bit LUT0 or DFF3 with RST/SET

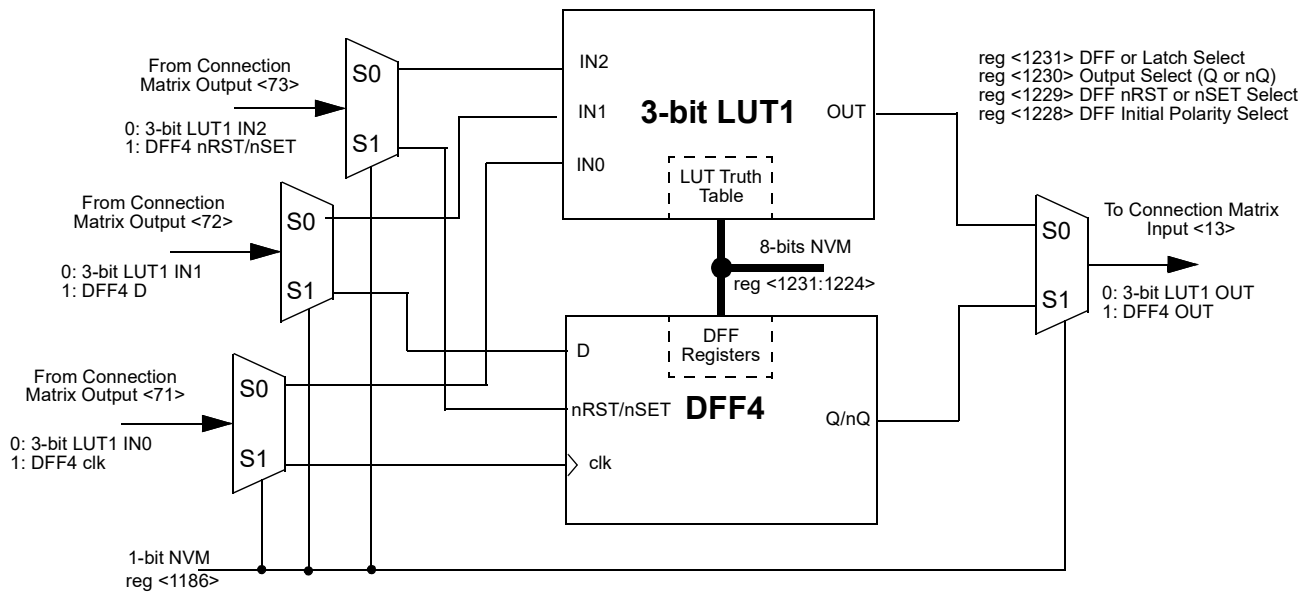

Figure 15. 3-bit LUT1 or DFF4 with RST/SET

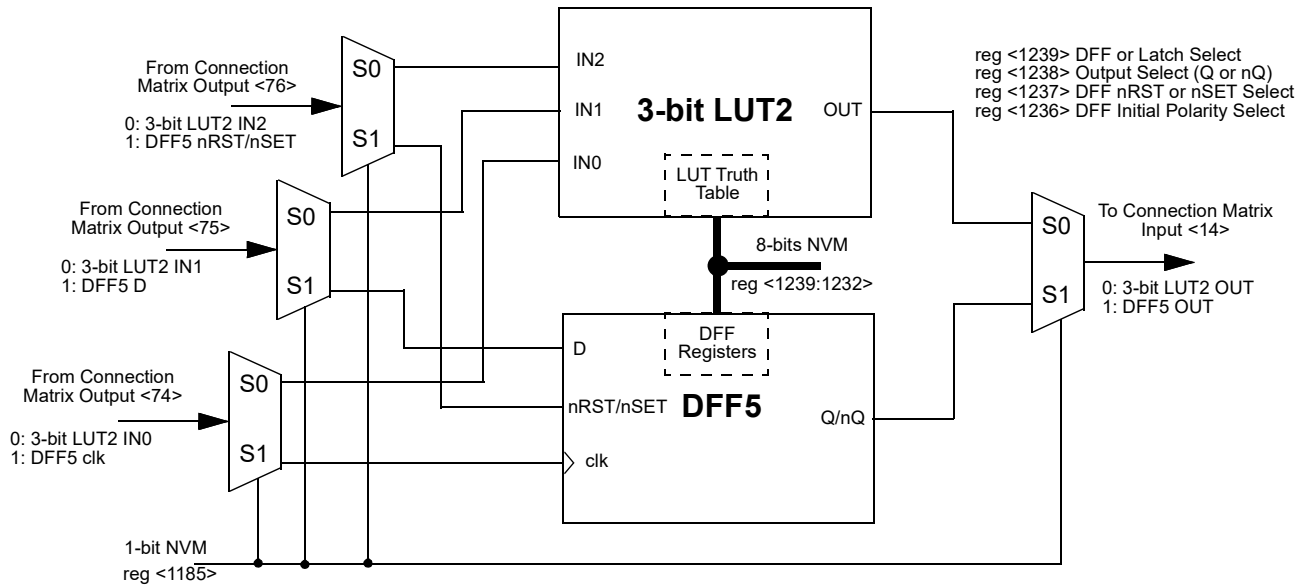

Figure 16. 3-bit LUT2 or DFF5 with RST/SET

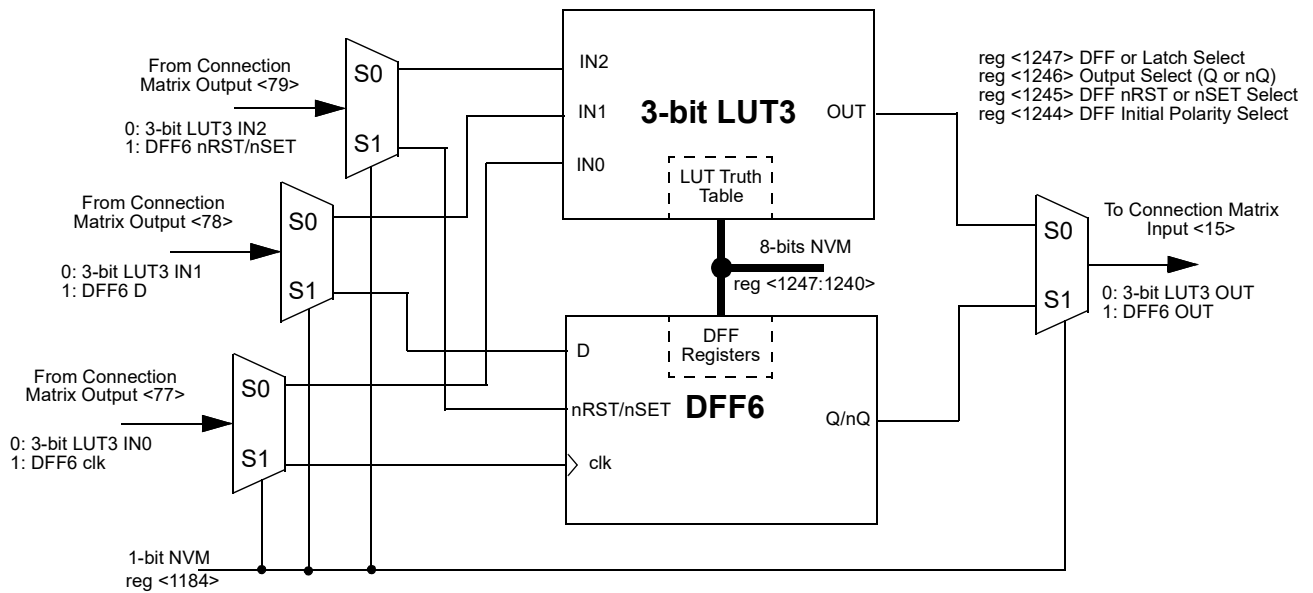

Figure 17. 3-bit LUT3 or DFF6 with RST/SET

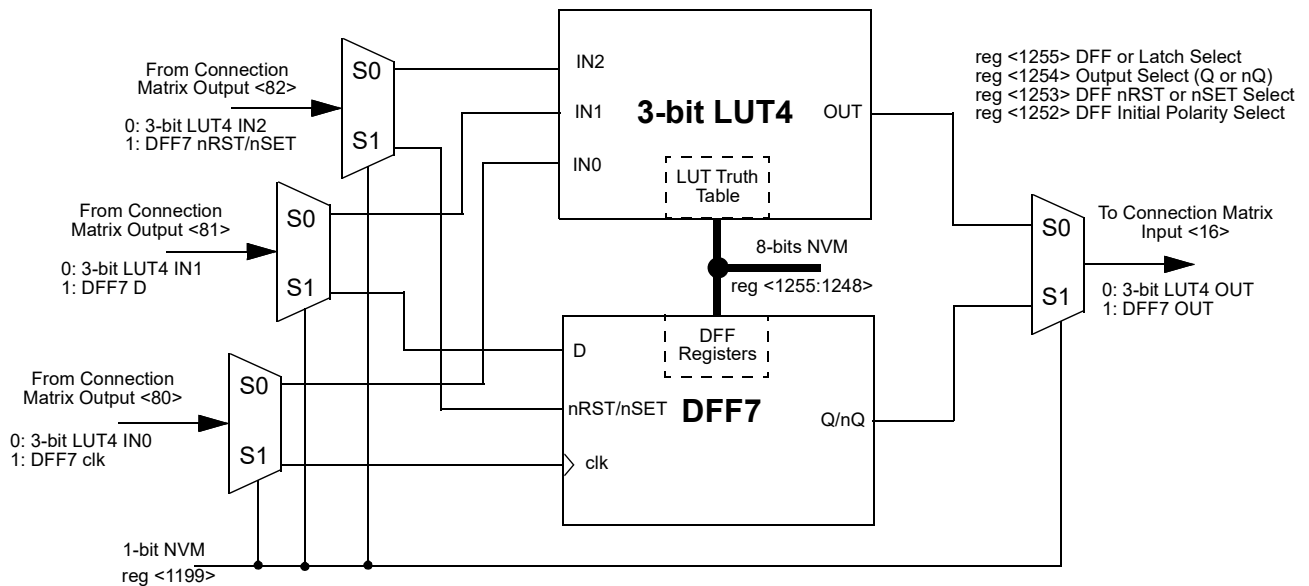

Figure 18. 3-bit LUT4 or DFF7 with RST/SET

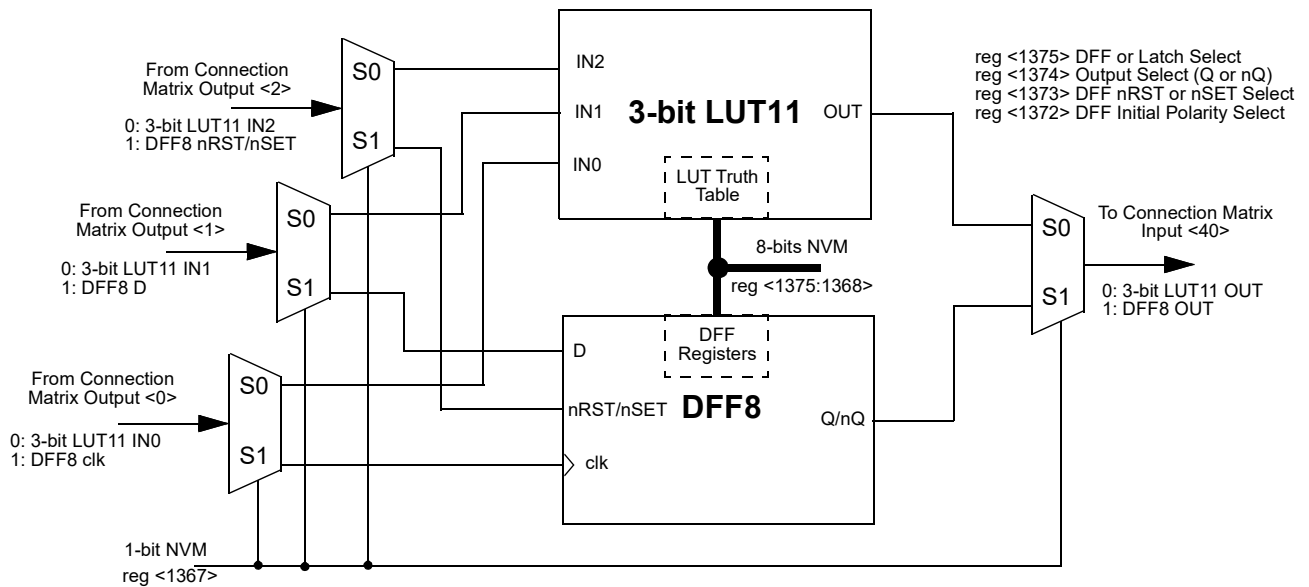

Figure 19. 3-bit LUT11 or DFF8 with RST/SET

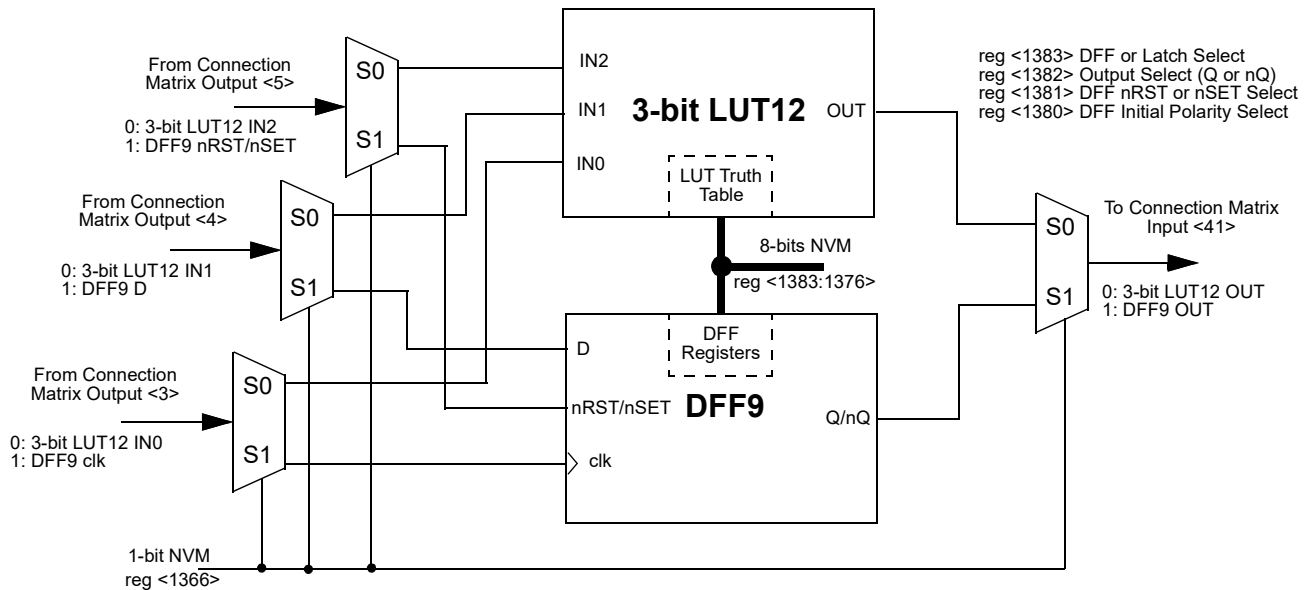

Figure 20. 3-bit LUT12 or DFF9 with RST/SET

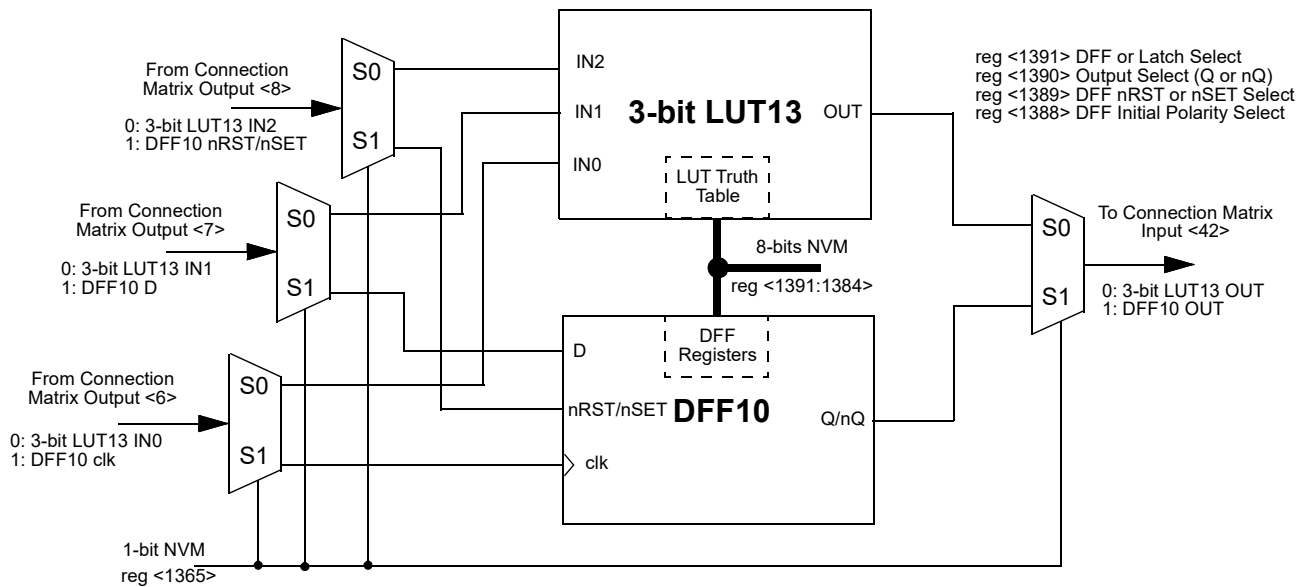

Figure 21. 3-bit LUT13 or DFF10 with RST/SET

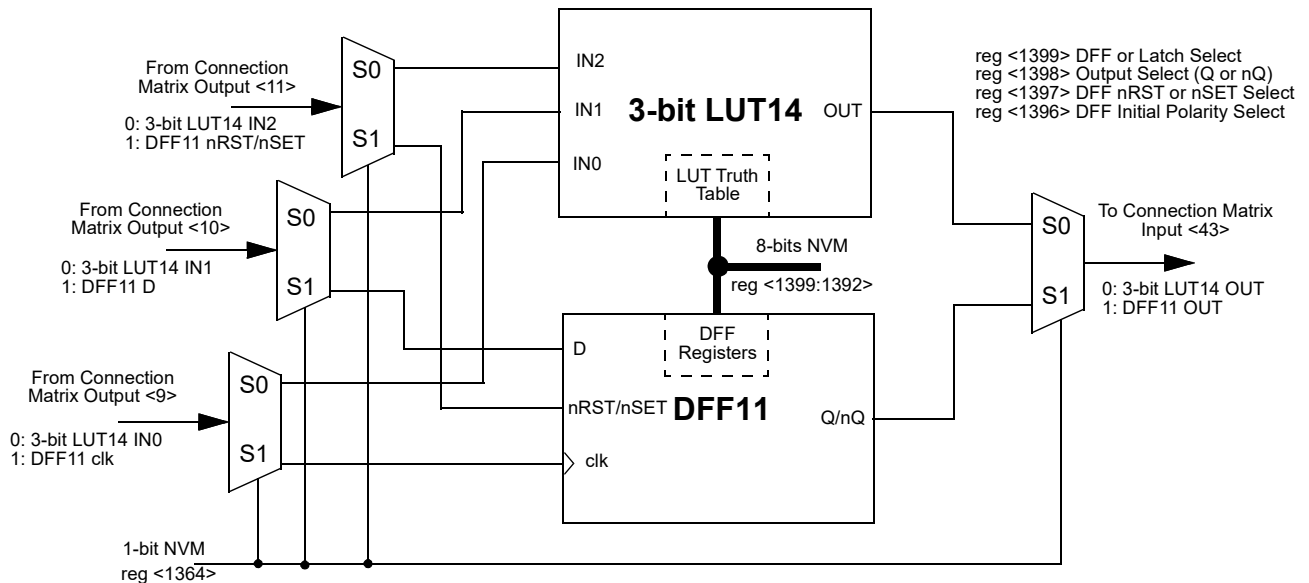

Figure 22. 3-bit LUT14 or DFF11 with RST/SET

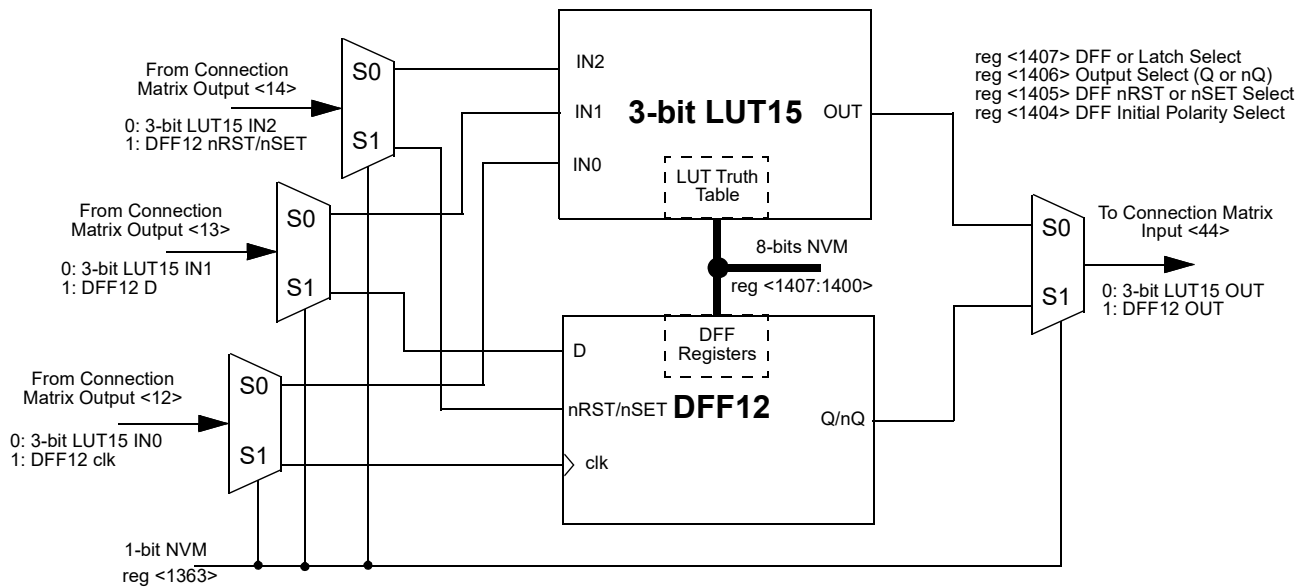

Figure 23. 3-bit LUT15 or DFF12 with RST/SET

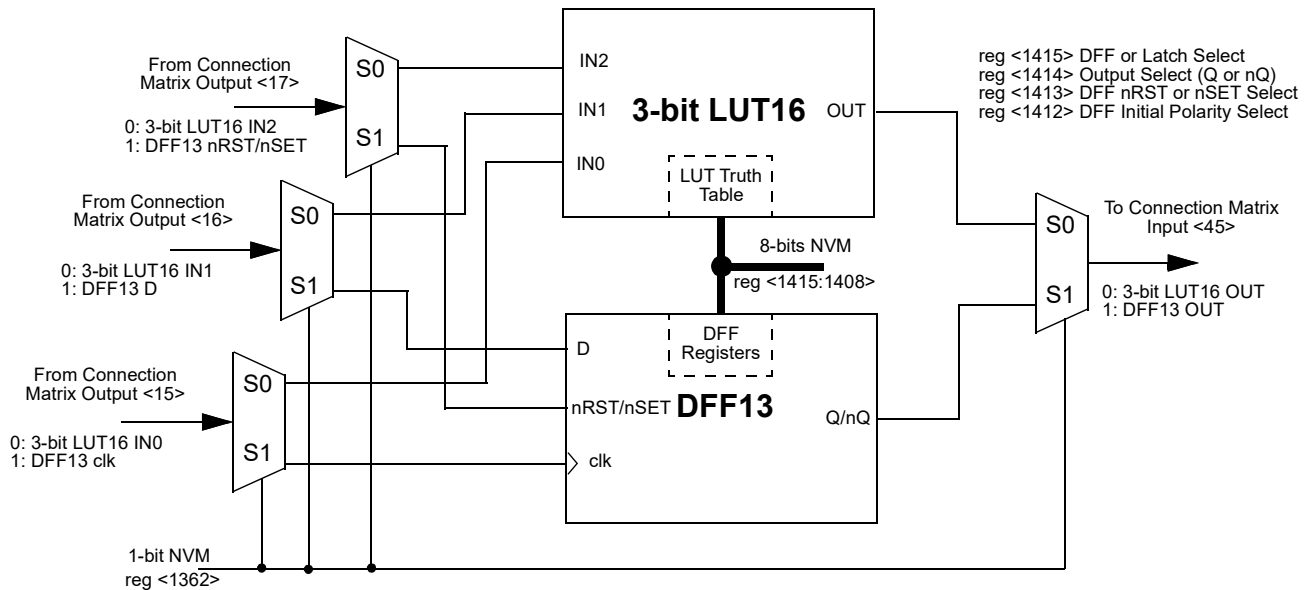

Figure 24. 3-bit LUT16 or DFF13 with RST/SET

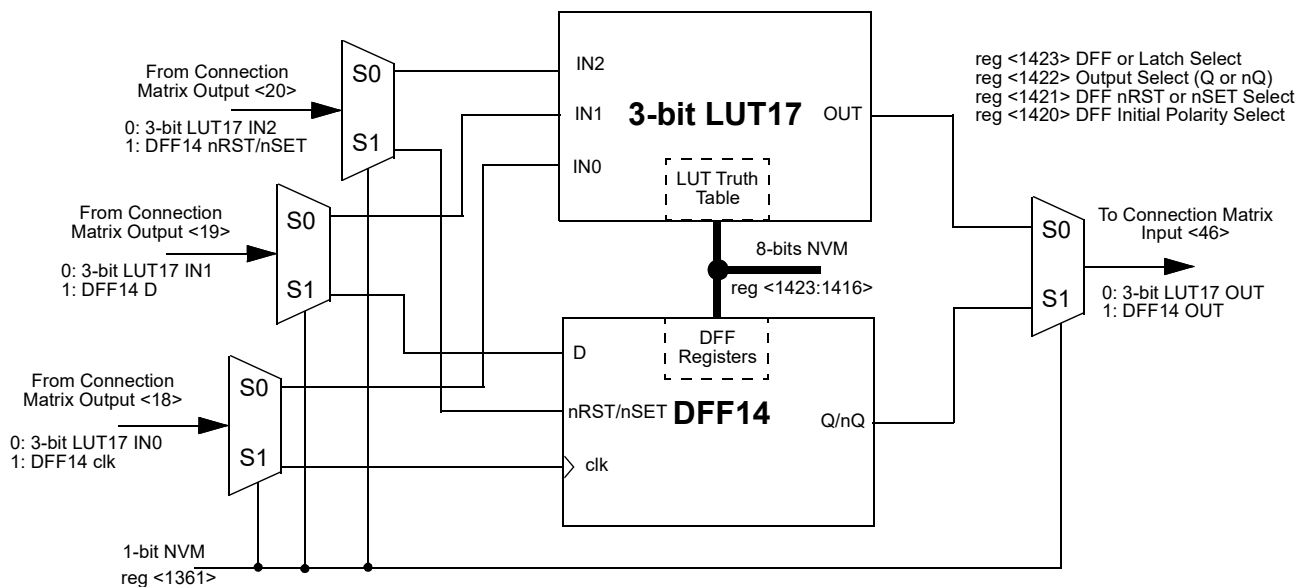

Figure 25. 3-bit LUT17 or DFF14 with RST/SET

9.3.1 3-Bit LUT or D Flip Flop Macrocells Used as 3-Bit LUTs

Table 37. 3-bit LUT0 Truth Table

| IN2 | IN1 | IN0 | OUT | |
|-----|-----|-----|------------|-----|
| 0 | 0 | 0 | reg <1216> | LSB |
| 0 | 0 | 1 | reg <1217> | |
| 0 | 1 | 0 | reg <1218> | |
| 0 | 1 | 1 | reg <1219> | |
| 1 | 0 | 0 | reg <1220> | |
| 1 | 0 | 1 | reg <1221> | |
| 1 | 1 | 0 | reg <1222> | |
| 1 | 1 | 1 | reg <1223> | MSB |

Table 38. 3-bit LUT1 Truth Table

| IN2 | IN1 | IN0 | OUT | |
|-----|-----|-----|------------|-----|
| 0 | 0 | 0 | reg <1224> | LSB |
| 0 | 0 | 1 | reg <1225> | |
| 0 | 1 | 0 | reg <1226> | |
| 0 | 1 | 1 | reg <1227> | |
| 1 | 0 | 0 | reg <1228> | |
| 1 | 0 | 1 | reg <1229> | |
| 1 | 1 | 0 | reg <1230> | |
| 1 | 1 | 1 | reg <1231> | MSB |

Table 39. 3-bit LUT2 Truth Table

| IN2 | IN1 | IN0 | OUT | |
|-----|-----|-----|------------|-----|
| 0 | 0 | 0 | reg <1232> | LSB |
| 0 | 0 | 1 | reg <1233> | |
| 0 | 1 | 0 | reg <1234> | |
| 0 | 1 | 1 | reg <1235> | |
| 1 | 0 | 0 | reg <1236> | |
| 1 | 0 | 1 | reg <1237> | |
| 1 | 1 | 0 | reg <1238> | |
| 1 | 1 | 1 | reg <1239> | MSB |

Table 40. 3-bit LUT3 Truth Table

| IN2 | IN1 | IN0 | OUT | |
|-----|-----|-----|------------|-----|
| 0 | 0 | 0 | reg <1240> | LSB |
| 0 | 0 | 1 | reg <1241> | |
| 0 | 1 | 0 | reg <1242> | |
| 0 | 1 | 1 | reg <1243> | |
| 1 | 0 | 0 | reg <1244> | |
| 1 | 0 | 1 | reg <1245> | |
| 1 | 1 | 0 | reg <1246> | |
| 1 | 1 | 1 | reg <1247> | MSB |

Table 41. 3-bit LUT4 Truth Table

| IN2 | IN1 | IN0 | OUT | |
|-----|-----|-----|------------|-----|
| 0 | 0 | 0 | reg <1248> | LSB |
| 0 | 0 | 1 | reg <1249> | |
| 0 | 1 | 0 | reg <1250> | |
| 0 | 1 | 1 | reg <1251> | |
| 1 | 0 | 0 | reg <1252> | |
| 1 | 0 | 1 | reg <1253> | |
| 1 | 1 | 0 | reg <1254> | |
| 1 | 1 | 1 | reg <1255> | MSB |

Table 42. 3-bit LUT11 Truth Table

| IN2 | IN1 | IN0 | OUT | |
|-----|-----|-----|------------|-----|
| 0 | 0 | 0 | reg <1368> | LSB |
| 0 | 0 | 1 | reg <1369> | |
| 0 | 1 | 0 | reg <1370> | |
| 0 | 1 | 1 | reg <1371> | |
| 1 | 0 | 0 | reg <1372> | |
| 1 | 0 | 1 | reg <1373> | |
| 1 | 1 | 0 | reg <1374> | |
| 1 | 1 | 1 | reg <1375> | MSB |

Table 43. 3-bit LUT12 Truth Table

| IN2 | IN1 | IN0 | OUT | |
|-----|-----|-----|------------|-----|
| 0 | 0 | 0 | reg <1376> | LSB |
| 0 | 0 | 1 | reg <1377> | |
| 0 | 1 | 0 | reg <1378> | |
| 0 | 1 | 1 | reg <1379> | |
| 1 | 0 | 0 | reg <1380> | |
| 1 | 0 | 1 | reg <1381> | |
| 1 | 1 | 0 | reg <1382> | |
| 1 | 1 | 1 | reg <1383> | MSB |

Table 44. 3-bit LUT13 Truth Table

| IN2 | IN1 | IN0 | OUT | |
|-----|-----|-----|------------|-----|
| 0 | 0 | 0 | reg <1384> | LSB |
| 0 | 0 | 1 | reg <1385> | |
| 0 | 1 | 0 | reg <1386> | |
| 0 | 1 | 1 | reg <1387> | |
| 1 | 0 | 0 | reg <1388> | |
| 1 | 0 | 1 | reg <1389> | |
| 1 | 1 | 0 | reg <1390> | |
| 1 | 1 | 1 | reg <1391> | MSB |

Table 45. 3-bit LUT14 Truth Table

| IN2 | IN1 | IN0 | OUT | |
|-----|-----|-----|------------|-----|
| 0 | 0 | 0 | reg <1392> | LSB |
| 0 | 0 | 1 | reg <1393> | |
| 0 | 1 | 0 | reg <1394> | |
| 0 | 1 | 1 | reg <1395> | |
| 1 | 0 | 0 | reg <1396> | |
| 1 | 0 | 1 | reg <1397> | |
| 1 | 1 | 0 | reg <1398> | |
| 1 | 1 | 1 | reg <1399> | MSB |

Table 46. 3-bit LUT15 Truth Table

| IN2 | IN1 | IN0 | OUT | |
|-----|-----|-----|------------|-----|
| 0 | 0 | 0 | reg <1400> | LSB |
| 0 | 0 | 1 | reg <1401> | |
| 0 | 1 | 0 | reg <1402> | |
| 0 | 1 | 1 | reg <1403> | |
| 1 | 0 | 0 | reg <1404> | |
| 1 | 0 | 1 | reg <1405> | |
| 1 | 1 | 0 | reg <1406> | |
| 1 | 1 | 1 | reg <1407> | MSB |

Table 47. 3-bit LUT16 Truth Table

| IN2 | IN1 | IN0 | OUT | |
|-----|-----|-----|------------|-----|
| 0 | 0 | 0 | reg <1408> | LSB |
| 0 | 0 | 1 | reg <1409> | |
| 0 | 1 | 0 | reg <1410> | |
| 0 | 1 | 1 | reg <1411> | |
| 1 | 0 | 0 | reg <1412> | |
| 1 | 0 | 1 | reg <1413> | |
| 1 | 1 | 0 | reg <1414> | |
| 1 | 1 | 1 | reg <1415> | MSB |

Table 48. 3-bit LUT17 Truth Table

| IN2 | IN1 | IN0 | OUT | |
|-----|-----|-----|------------|-----|
| 0 | 0 | 0 | reg <1416> | LSB |
| 0 | 0 | 1 | reg <1417> | |
| 0 | 1 | 0 | reg <1418> | |
| 0 | 1 | 1 | reg <1419> | |
| 1 | 0 | 0 | reg <1420> | |
| 1 | 0 | 1 | reg <1421> | |
| 1 | 1 | 0 | reg <1422> | |
| 1 | 1 | 1 | reg <1423> | MSB |

Each Macrocell, when programmed for a LUT function, uses a 8-bit register to define their output function:

3-Bit LUT0 is defined by reg<1223:1216>

3-Bit LUT1 is defined by reg<1231:1324>

3-Bit LUT2 is defined by reg<1239:1232>

3-Bit LUT3 is defined by reg<1247:1240>

3-Bit LUT4 is defined by reg<1255:1248>

The table below shows the register bits for the standard digital logic devices (AND, NAND, OR, NOR, XOR, XNOR) that can be created within each of the six 3-bit LUT logic cells.

Table 49. 3-bit LUT Standard Digital Functions

| Function | MSB | | | | | | | LSB |
|----------|-----|---|---|---|---|---|---|-----|
| AND-3 | 1 | 0 | 0 | 0 | 0 | 0 | 0 | 0 |
| NAND-3 | 0 | 1 | 1 | 1 | 1 | 1 | 1 | 1 |
| OR-3 | 1 | 1 | 1 | 1 | 1 | 1 | 1 | 0 |
| NOR-3 | 0 | 0 | 0 | 0 | 0 | 0 | 0 | 1 |
| XOR-3 | 1 | 0 | 0 | 1 | 0 | 1 | 1 | 0 |
| XNOR-3 | 0 | 1 | 1 | 0 | 1 | 0 | 0 | 1 |

9.3.2 3-Bit LUT or D Flip Flop Macrocells Used as D Flip Flop Register Settings
Table 50. DFF3 Register Settings

| Signal Function | Register Bit Address | Register Definition |
|------------------------------|----------------------|--|
| LUT3_0 or DFF3 Select | reg<1187> | 0: LUT3_0 1: DFF3 |
| DFF3 Initial Polarity Select | reg<1220> | 0: Low 1: High |
| DFF3 nRST/nSET Select | reg<1221> | 1: nSET from matrix out 0: nRST from matrix out |
| DFF3 Output Select | reg<1222> | 0: Q output 1: nQ output |
| DFF3 or Latch Select | reg<1223> | 0: DFF function 1: Latch function |

Table 51. DFF4 Register Settings

| Signal Function | Register Bit Address | Register Definition |
|------------------------------|----------------------|--|
| LUT3_1 or DFF4 Select | reg<1186> | 0: LUT3_1 1: DFF4 |
| DFF4 Initial Polarity Select | reg<1128> | 0: Low 1: High |
| DFF4 nRST/nSET Select | reg<1129> | 1: nSET from matrix out 0: nRST from matrix out |
| DFF4 Output Select | reg<1130> | 0: Q output 1: nQ output |
| DFF4 or Latch Select | reg<1131> | 0: DFF function 1: Latch function |

Table 52. DFF5 Register Settings

| Signal Function | Register Bit Address | Register Definition |
|------------------------------|----------------------|--|
| LUT3_2 or DFF5 Select | reg<1185> | 0: LUT3_2 1: DFF5 |
| DFF5 Initial Polarity Select | reg<1236> | 0: Low 1: High |
| DFF5 nRST/nSET Select | reg<1237> | 1: nSET from matrix out 0: nRST from matrix out |
| DFF5 Output Select | reg<1238> | 0: Q output 1: nQ output |
| DFF5 or Latch Select | reg<1239> | 0: DFF function 1: Latch function |

Table 53. DFF6 Register Settings

| Signal Function | Register Bit Address | Register Definition |
|------------------------------|----------------------|--|
| LUT3_3 or DFF6 Select | reg<1184> | 0: LUT3_3 1: DFF6 |
| DFF6 Initial Polarity Select | reg<1244> | 0: Low 1: High |
| DFF6 nRST/nSET Select | reg<1245> | 1: nSET from matrix out 0: nRST from matrix out |
| DFF6 Output Select | reg<1246> | 0: Q output 1: nQ output |
| DFF6 or Latch Select | reg<1247> | 0: DFF function 1: Latch function |

Table 54. DFF7 Register Settings

| Signal Function | Register Bit Address | Register Definition |
|------------------------------|----------------------|--|
| LUT3_4 or DFF7 Select | reg<1199> | 0: LUT3_4 1: DFF7 |
| DFF7 Initial Polarity Select | reg<1252> | 0: Low 1: High |
| DFF7 nRST/nSET Select | reg<1253> | 1: nSET from matrix out 0: nRST from matrix out |
| DFF7 Output Select | reg<1254> | 0: Q output 1: nQ output |
| DFF7 or Latch Select | reg<1255> | 0: DFF function 1: Latch function |

9.4 Initial Polarity Operations

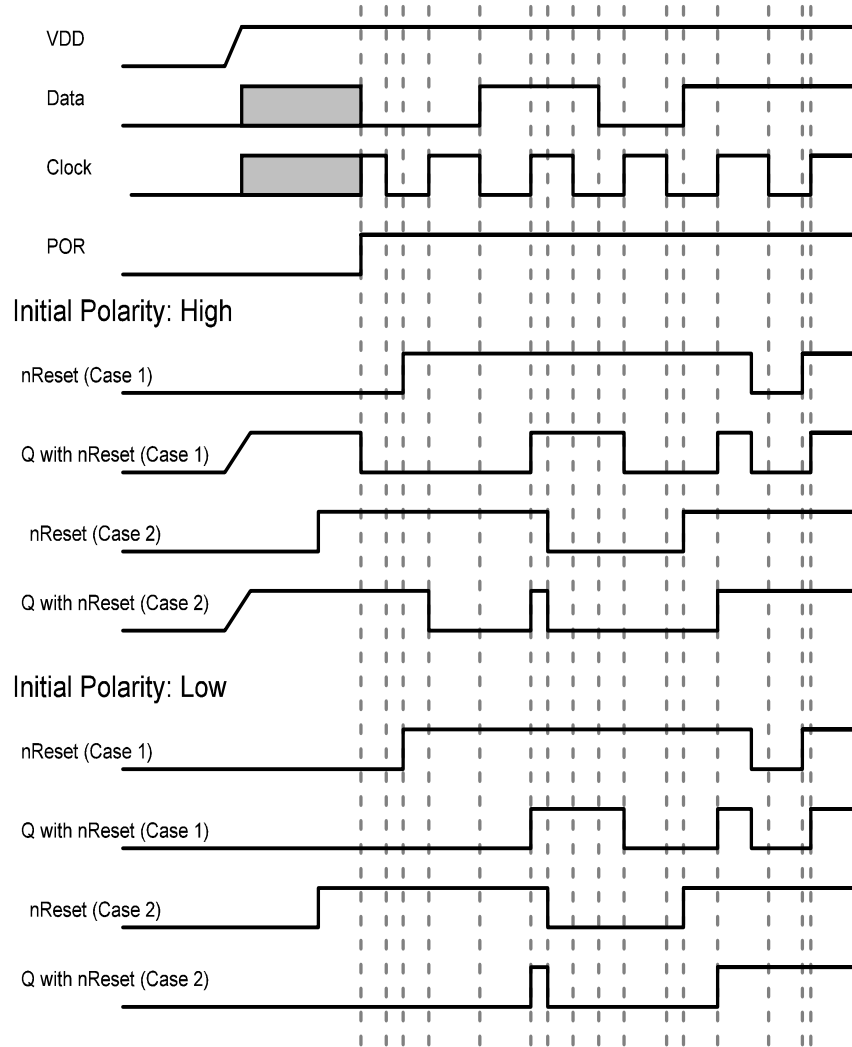

Figure 26. DFF Polarity Operations with nReset

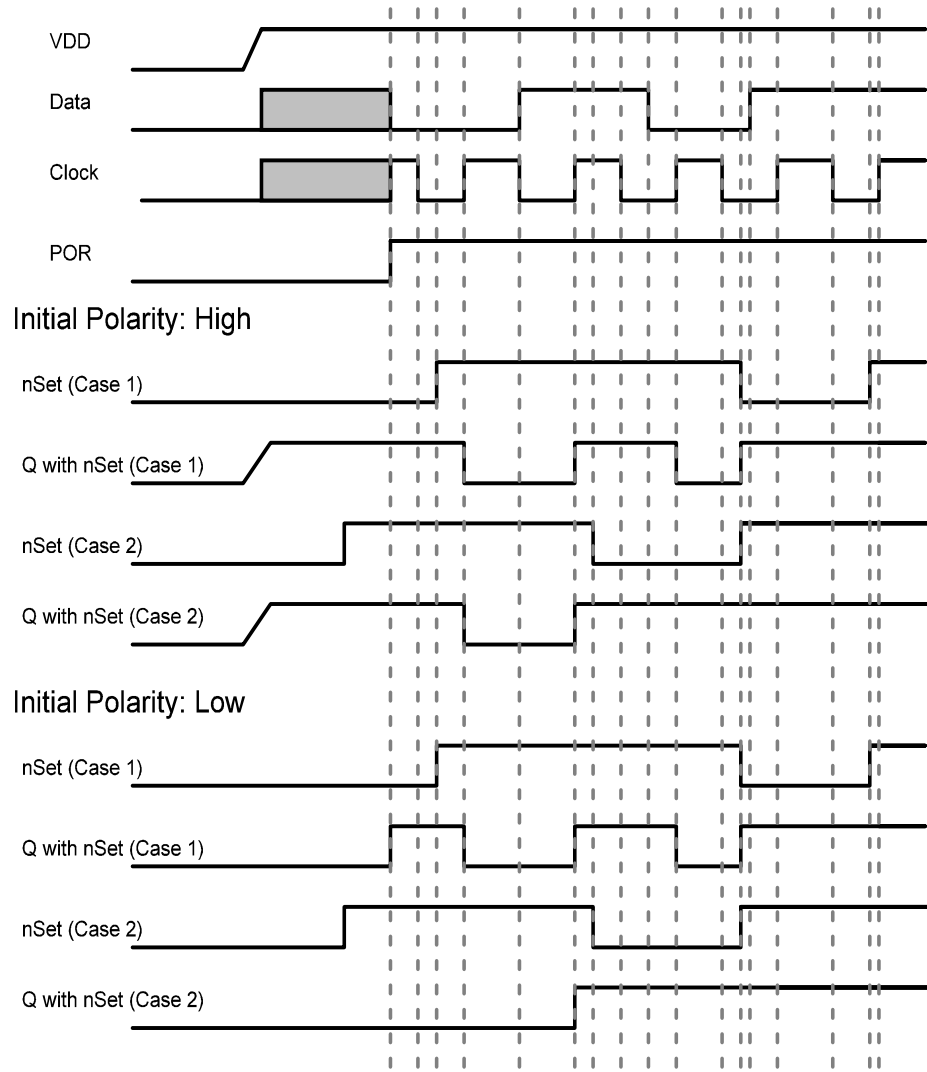

Figure 27. DFF Polarity Operations with nSet

9.5 3-Bit LUT or Pipe Delay Macrocell

There is one macrocell that can serve as either a 3-bit LUT or as a Pipe Delay.

When used to implement LUT functions, the 3-bit LUT take in three input signals from the connection matrix and produces a single output, which goes back into the connection matrix.

When used as a pipe delay, there are three inputs signals from the matrix, Input (IN), Clock (CLK) and Reset (nRST). The pipe delay cell is built from 16 D Flip-Flop logic cells that provide the three output options, two of which are user selectable. The DFF cells are tied in series where the output (Q) of each delay cell goes to the next DFF cell. The first delay option is fixed at the output of the first flip-flop stage. The other two outputs (OUT0 and OUT1) provide user selectable options for 1 – 16 stages of delay. There are delay output points for each set of the OUT0 and OUT1 outputs to a 16-input mux that is controlled by reg <1259:1256> for OUT0 and reg <1263:1260> for OUT1. The 16-input mux is used to select the amount of delay.

The overall time of the delay is based on the clock used in the SLG46534 design. Each DFF cell has a time delay of the inverse of the clock time (either external clock or the RC Oscillator within the SLG46534). The sum of the number of DFF cells used will be the total time delay of the Pipe Delay logic cell.

Note: CLK is rising edge triggered.

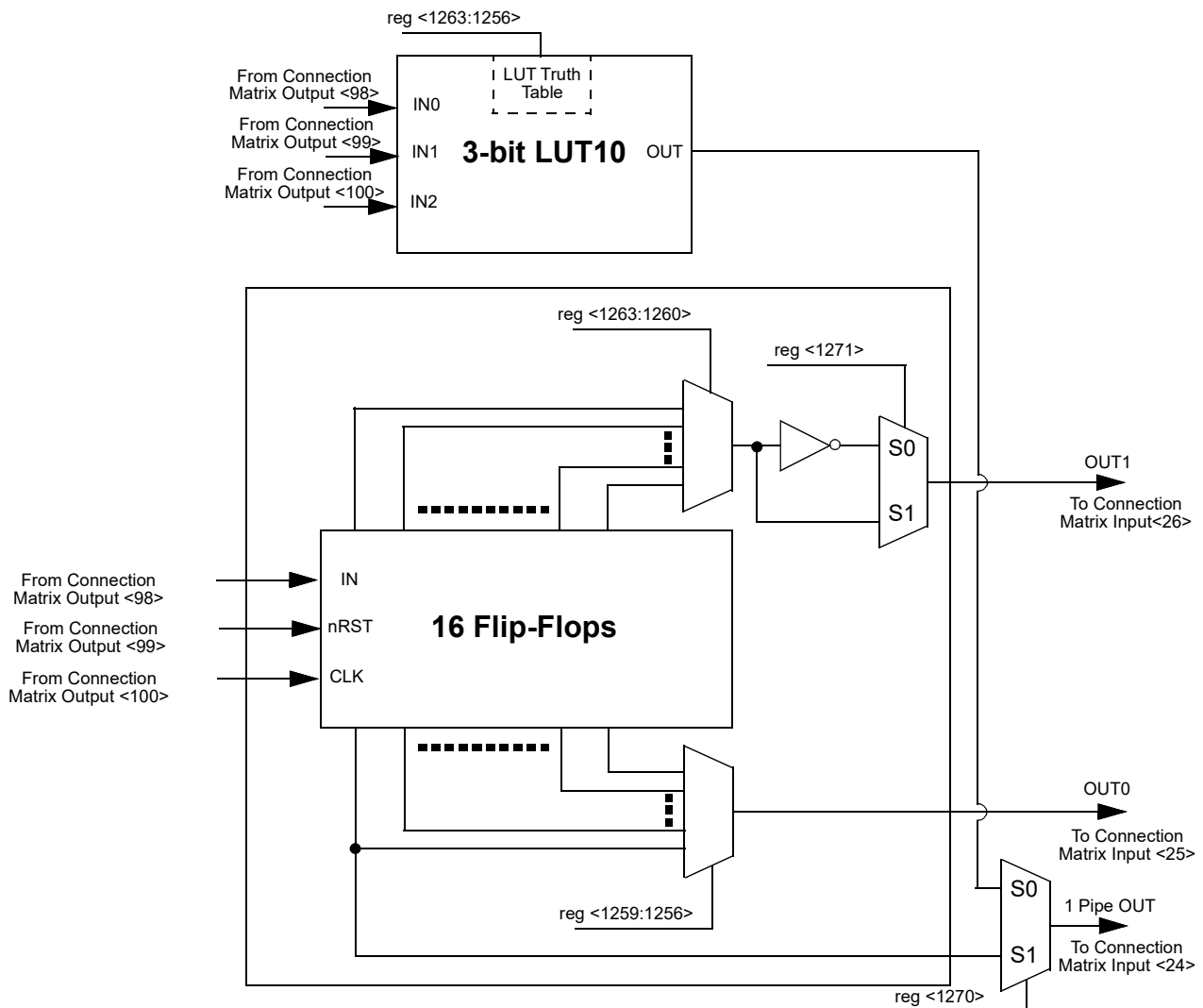

Figure 28. 3-bit LUT10 or Pipe Delay

9.5.1 3-Bit LUT or Pipe Delay Macrocells Used as 3-Bit LUTs

Table 55. 3-bit LUT10 Truth Table

| IN2 | IN1 | IN0 | OUT | |
|-----|-----|-----|------------|-----|
| 0 | 0 | 0 | reg <1256> | LSB |
| 0 | 0 | 1 | reg <1257> | |
| 0 | 1 | 0 | reg <1258> | |
| 0 | 1 | 1 | reg <1259> | |
| 1 | 0 | 0 | reg <1260> | |
| 1 | 0 | 1 | reg <1261> | |
| 1 | 1 | 0 | reg <1262> | |
| 1 | 1 | 1 | reg <1263> | MSB |

Each Macrocell, when programmed for a LUT function, uses a 8-bit register to define their output function:

3-Bit LUT10 is defined by reg<1263:1256>

9.5.2 3-Bit LUT or Pipe Delay Macrocells Used as Pipe Delay Register Settings

Table 56. Pipe Delay Register Settings

| Signal Function | Register Bit Address | Register Definition |
|-------------------------------------|----------------------|--------------------------------------|
| LUT3_10 or Pipe Delay Output Select | reg<1270> | 0: LUT3_10 1: 1 Pipe Delay Output |
| OUT0 select | reg<1259:1256> | |
| OUT1 select | reg<1263:1260> | |
| Pipe delay OUT1 Polarity Select Bit | reg<1271> | 0: Non-inverted 1: Inverted |

9.6 3-Bit LUT or 8-Bit Counter / Delay Macrocells

There are five macrocells that can serve as either 3-bit LUTs or as Counter / Delays. When used to implement LUT function, the 3-bit LUT takes in three input signals from the connection matrix and produces a single output, which goes back into the connection matrix. When used to implement 8-Bit Counter / Delay function, two of the three input signals from the connection matrix go to the external clock (ext_clk) and reset (DLY_in/CNT_Reset) for the counter/delay, with the output going back to the connection matrix.

These macrocells can also operate in a one-shot mode, which will generate an output pulse of user-defined width.

These macrocells can also operate in a frequency detection or edge detection mode.

For timing diagrams refer to section 9.8 CNT/DLY/FSM Timing Diagrams

Note: Counters initialize with counter data after POR

Two of the five macrocells can have their active count value read via I²C (CNT4 and CNT6). See Section 19.5.1.2 Reading Counter Data via I2C for further details.

9.6.1 3-Bit LUT or 8- Bit CNT/DLY Block Diagrams

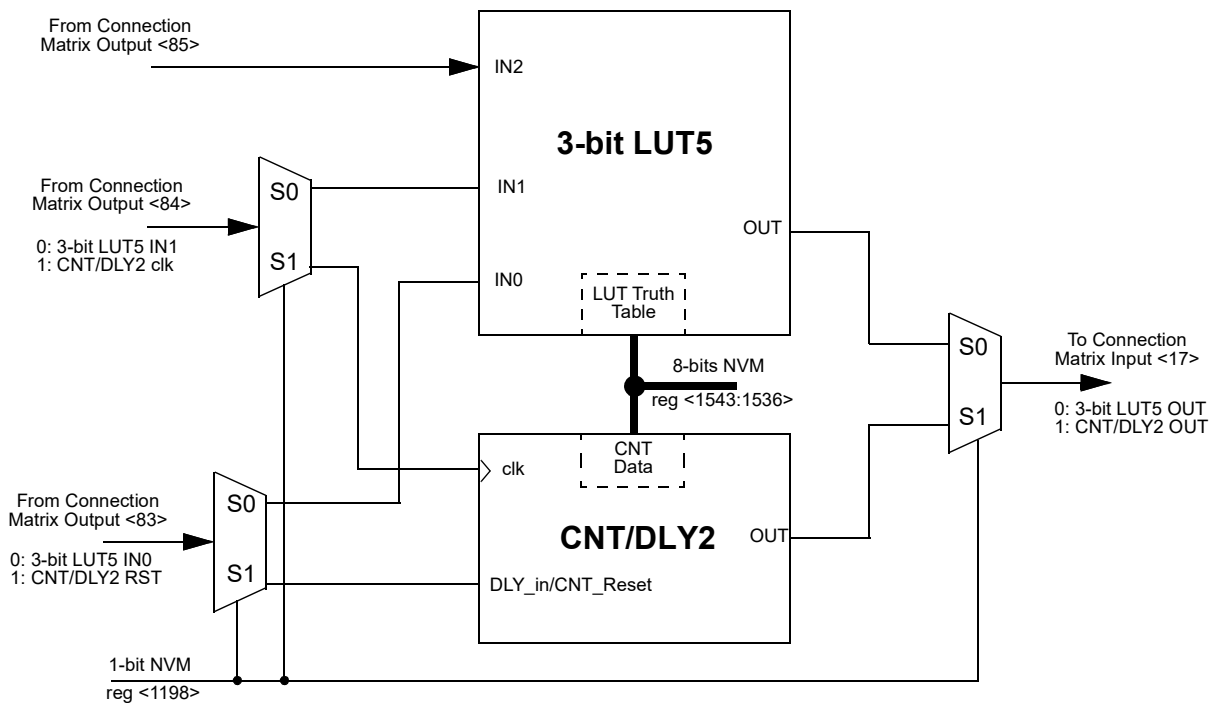

Figure 29. 3-bit LUT5 or CNT/DLY2

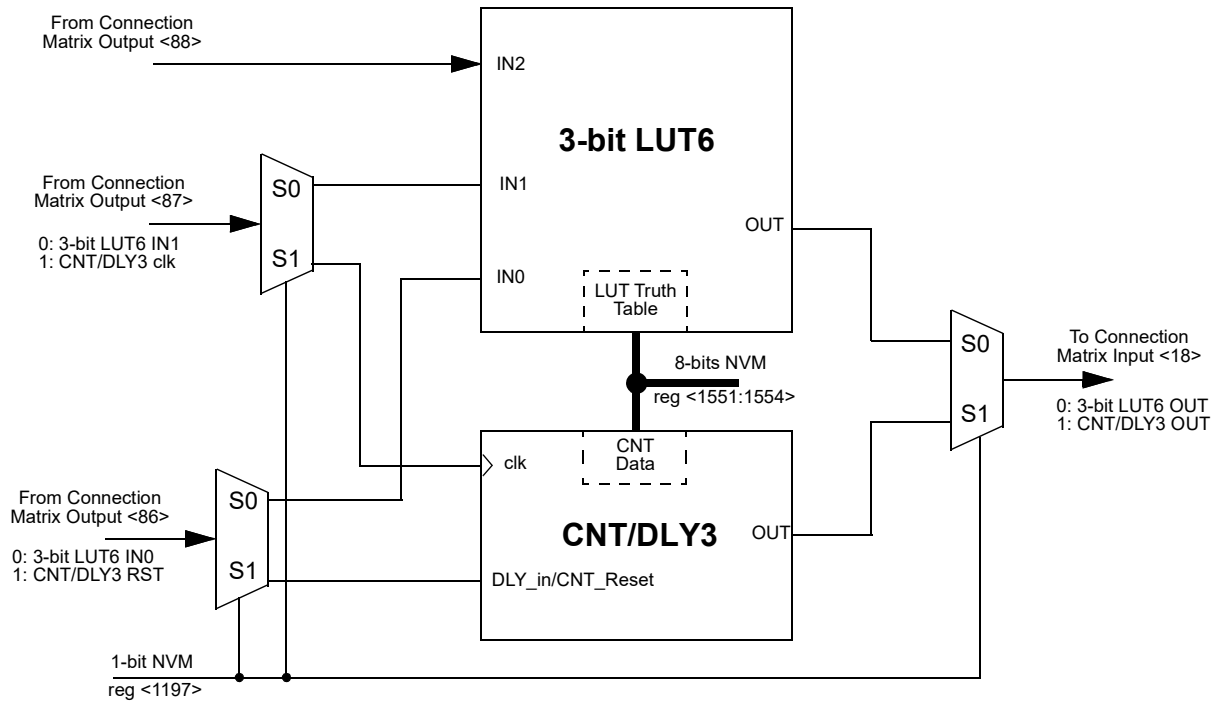

Figure 30. 3-bit LUT6 or CNT/DLY3

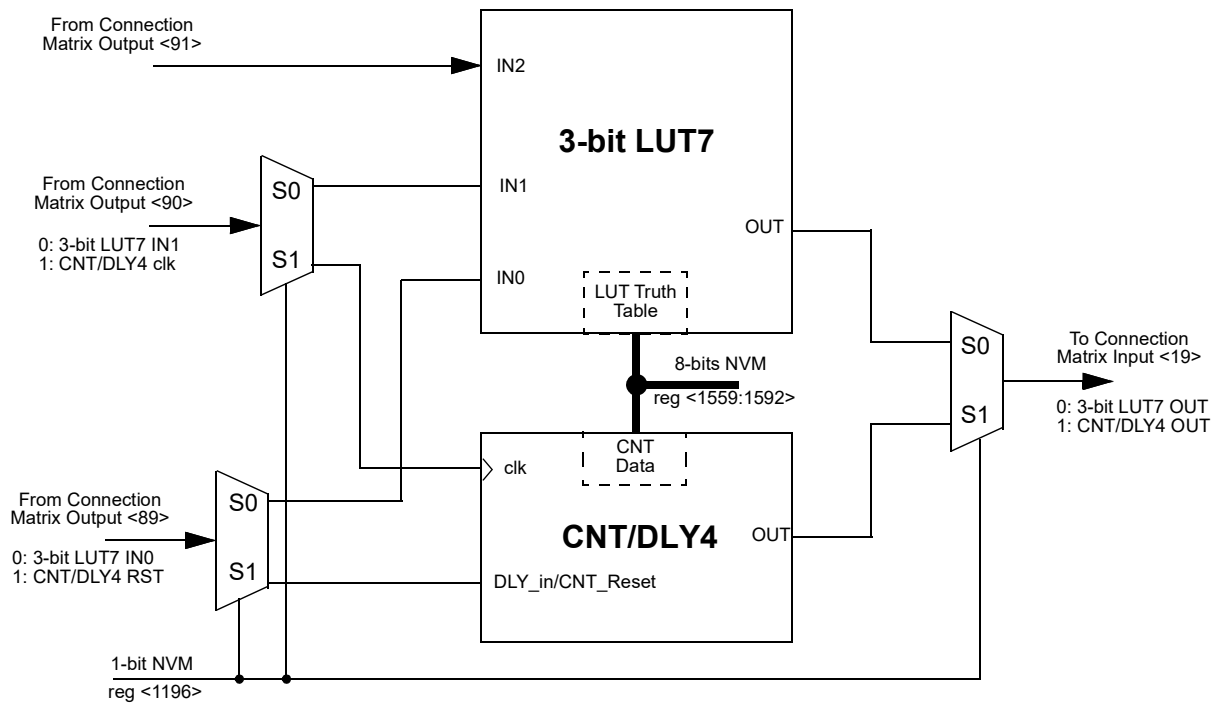

Figure 31. 3-bit LUT7 or CNT/DLY4

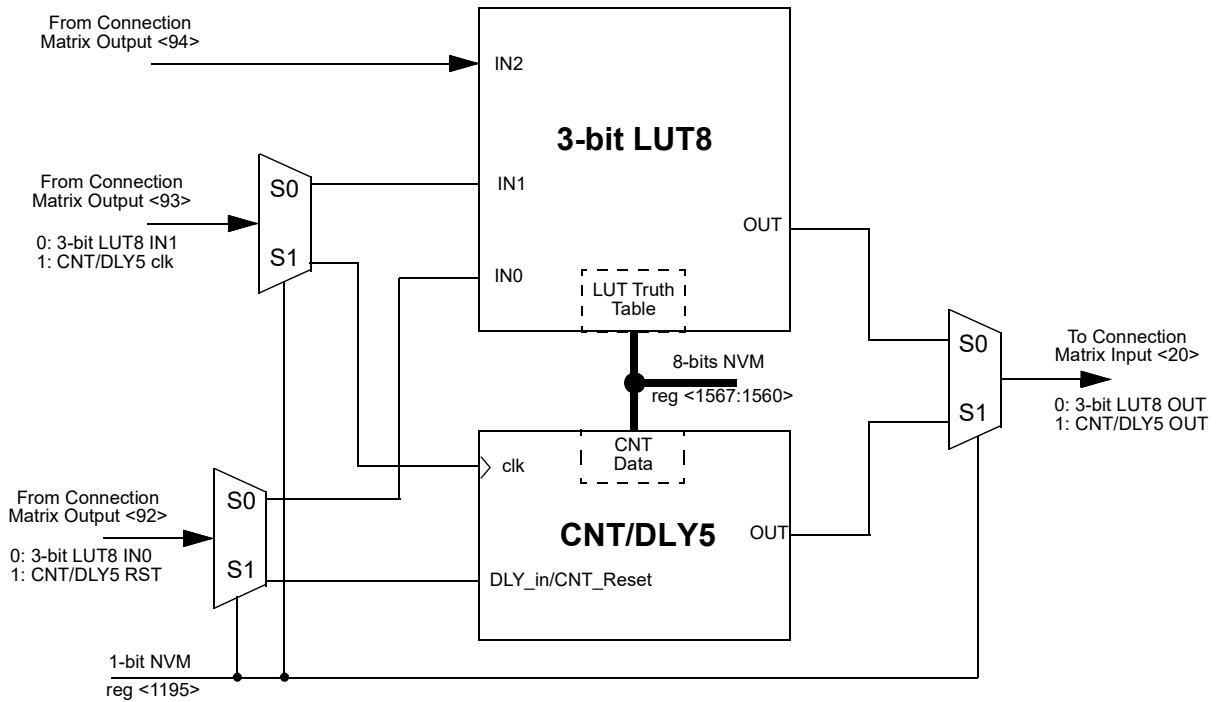

Figure 32. 3-bit LUT8 or CNT/DLY5

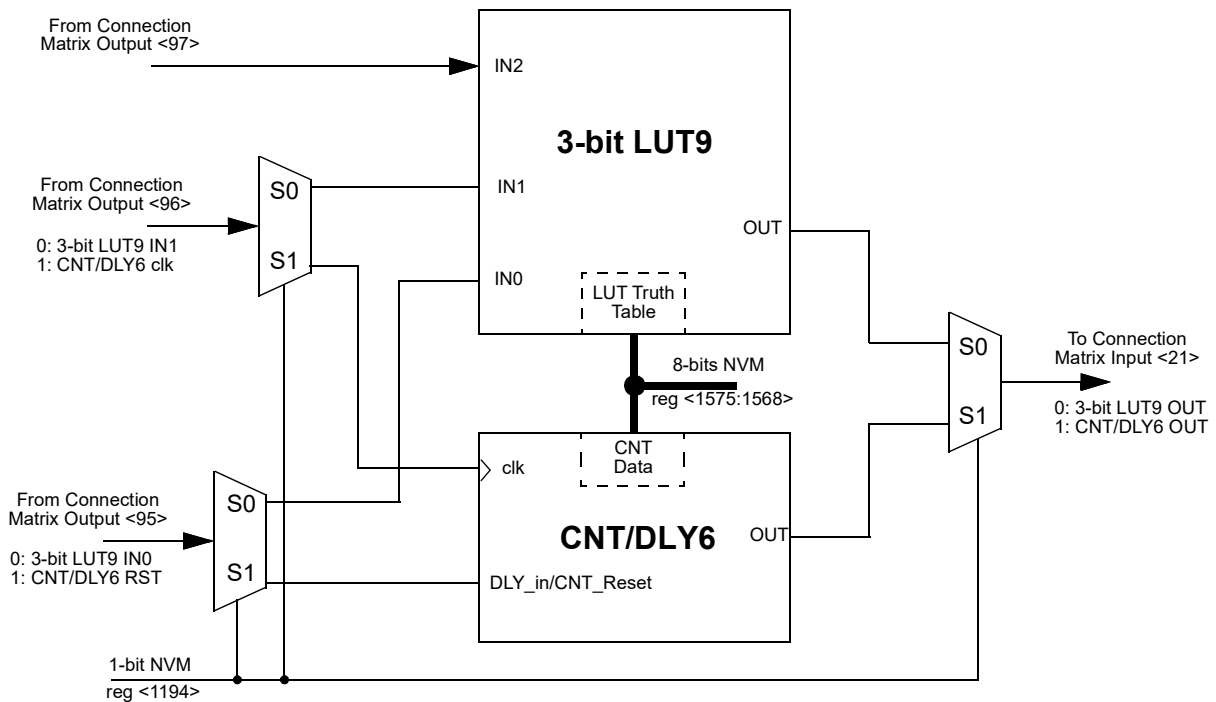

Figure 33. 3-bit LUT9 or CNT/DLY6

9.6.2 3-Bit LUT or CNT/DLYs Used as 3-Bit LUTs

Table 57. 3-bit LUT5 Truth Table

| IN2 | IN1 | IN0 | OUT | |
|-----|-----|-----|------------|-----|
| 0 | 0 | 0 | reg <1536> | LSB |
| 0 | 0 | 1 | reg <1537> | |
| 0 | 1 | 0 | reg <1538> | |
| 0 | 1 | 1 | reg <1539> | |
| 1 | 0 | 0 | reg <1540> | |
| 1 | 0 | 1 | reg <1541> | |
| 1 | 1 | 0 | reg <1542> | |
| 1 | 1 | 1 | reg <1543> | MSB |

Table 58. 3-bit LUT6 Truth Table

| IN2 | IN1 | IN0 | OUT | |
|-----|-----|-----|------------|-----|
| 0 | 0 | 0 | reg <1544> | LSB |
| 0 | 0 | 1 | reg <1545> | |
| 0 | 1 | 0 | reg <1546> | |
| 0 | 1 | 1 | reg <1547> | |
| 1 | 0 | 0 | reg <1548> | |
| 1 | 0 | 1 | reg <1549> | |
| 1 | 1 | 0 | reg <1550> | |
| 1 | 1 | 1 | reg <1551> | MSB |

Table 59. 3-bit LUT7 Truth Table

| IN2 | IN1 | IN0 | OUT | |
|-----|-----|-----|------------|-----|
| 0 | 0 | 0 | reg <1552> | LSB |
| 0 | 0 | 1 | reg <1553> | |
| 0 | 1 | 0 | reg <1554> | |
| 0 | 1 | 1 | reg <1555> | |
| 1 | 0 | 0 | reg <1556> | |
| 1 | 0 | 1 | reg <1557> | |
| 1 | 1 | 0 | reg <1558> | |
| 1 | 1 | 1 | reg <1559> | MSB |

Table 60. 3-bit LUT8 Truth Table

| IN2 | IN1 | IN0 | OUT | |
|-----|-----|-----|------------|-----|
| 0 | 0 | 0 | reg <1560> | LSB |
| 0 | 0 | 1 | reg <1561> | |
| 0 | 1 | 0 | reg <1562> | |
| 0 | 1 | 1 | reg <1563> | |
| 1 | 0 | 0 | reg <1564> | |
| 1 | 0 | 1 | reg <1565> | |
| 1 | 1 | 0 | reg <1566> | |
| 1 | 1 | 1 | reg <1567> | MSB |

Table 61. 3-bit LUT9 Truth Table

| IN2 | IN1 | IN0 | OUT | |
|-----|-----|-----|------------|-----|
| 0 | 0 | 0 | reg <1568> | LSB |
| 0 | 0 | 1 | reg <1569> | |
| 0 | 1 | 0 | reg <1570> | |
| 0 | 1 | 1 | reg <1571> | |
| 1 | 0 | 0 | reg <1572> | |
| 1 | 0 | 1 | reg <1573> | |
| 1 | 1 | 0 | reg <1574> | |
| 1 | 1 | 1 | reg <1575> | MSB |

Each Macrocell, when programmed for a LUT function, uses a 8-bit register to define their output function:

3-Bit LUT5 is defined by reg<1543:1536>

3-Bit LUT6 is defined by reg<1551:1544>

3-Bit LUT7 is defined by reg<1559:1552>

3-Bit LUT8 is defined by reg<1567:1560>

3-Bit LUT9 is defined by reg<1575:1568>

9.6.3 3-Bit LUT or 8-Bit Counter / Delay Macrocells Used as 8-Bit Counter / Delay Register Settings
Table 62. CNT/DLY2 Register Settings

| Signal Function | Register Bit Address | Register Definition |
|--|----------------------|--|
| LUT3_5 or Counter2 Select | reg<1198> | 0: LUT3_5 1: Counter2 |
| Delay2 Mode Select or asynchronous counter reset | reg<1273:1272> | 00: on both falling and rising edges (for delay & counter reset) 01: on falling edge only (for delay & counter reset) 10: on rising edge only (for delay & counter reset) 11: no delay on either falling or rising edges / counter high level reset |
| Counter/delay2 Clock Source Select | reg<1276:1274> | 000: Internal OSC clock 001: OSC/4 010: OSC/12 011: OSC/24 100: OSC/64 101: 25MHz OSC clock 110: External Clock 111: Counter1 Overflow |
| Counter/delay2 Output Selection for Counter mode | reg<1277> | 0: Default Output 1: Edge Detector Output |
| Counter/delay2 Mode Selection | reg<1279:1278> | 00: Delay mode 01: One Shot 10: Freq. Detect 11: Counter mode |
| Counter/delay2 Control Data | reg<1543:1536> | 1 – 255 |

Table 63. CNT/DLY3 Register Settings

| Signal Function | Register Bit Address | Register Definition |
|--|----------------------|--|
| LUT3_6 or Counter3 Select | reg<1197> | 0: LUT3_6 1: Counter3 |
| Delay3 Mode Select or asynchronous counter reset | reg<1281:1280> | 00: on both falling and rising edges (for delay & counter reset) 01: on falling edge only (for delay & counter reset) 10: on rising edge only (for delay & counter reset) 11: no delay on either falling or rising edges / counter high level reset |
| Counter/delay3 Clock Source Select | reg<1284:1282> | 000: Internal OSC clock 001: OSC/4 010: OSC/12 011: OSC/24 100: OSC/64 101: 25MHz OSC clock 110: External Clock 111: Counter2 Overflow |
| Counter/delay3 Output Selection for Counter mode | reg<1285> | 0: Default Output 1: Edge Detector Output |
| Counter/delay2 Mode Selection | reg<1287:1286> | 00: Delay mode 01: One Shot 10: Freq. Detect 11: Counter mode |
| Counter/delay3 Control Data | reg<1551:1544> | 1 – 255 |

Table 64. CNT/DLY4 Register Settings

| Signal Function | Register Bit Address | Register Definition |
|--|----------------------|--|
| LUT3_7 or Counter4 Select | reg<1196> | 0: LUT3_7 1: Counter4 |
| Delay4 Mode Select or asynchronous counter reset | reg<1289:1288> | 00: on both falling and rising edges (for delay & counter reset) 01: on falling edge only (for delay & counter reset) 10: on rising edge only (for delay & counter reset) 11: no delay on either falling or rising edges / counter high level reset |
| Counter/delay4 Clock Source Select | reg<1292:1290> | 000: Internal OSC clock 001: OSC/4 010: OSC/12 011: OSC/24 100: OSC/64 101: 25MHz OSC clock 110: External Clock 111: Counter3 Overflow |
| Counter/delay4 Output Selection for Counter mode | reg<1293> | 0: Default Output 1: Edge Detector Output |
| Counter/delay4 Mode Selection | reg<1295:1294> | 00: Delay mode 01: One Shot 10: Freq. Detect 11: Counter mode |
| Counter/delay4 Control Data | reg<1559:1552> | 1 – 255 |

Table 65. CNT/DLY5 Register Settings

| Signal Function | Register Bit Address | Register Definition |
|--|----------------------|--|
| LUT3_8 or Counter5 Select | reg<1195> | 0: LUT3_8 1: Counter5 |
| Delay5 Mode Select or asynchronous counter reset | reg<1297:1296> | 00: on both falling and rising edges (for delay & counter reset) 01: on falling edge only (for delay & counter reset) 10: on rising edge only (for delay & counter reset) 11: no delay on either falling or rising edges / counter high level reset |
| Counter/delay5 Clock Source Select | reg<1300:1298> | 000: Internal OSC clock 001: OSC/4 010: OSC/12 011: OSC/24 100: OSC/64 101: 25 MHz OSC clock 110: External Clock 111: Counter4 Overflow |
| Counter/delay5 Output Selection for Counter mode | reg<1301> | 0: Default Output 1: Edge Detector Output |
| Counter/delay5 Mode Selection | reg<1303:1302> | 00: Delay mode 01: One Shot 10: Freq. Detect 11: Counter mode |
| Counter/delay5 Control Data | reg<1567:1560> | 1 – 255 |

Table 66. CNT/DLY6 Register Settings

| Signal Function | Register Bit Address | Register Definition |
|--|----------------------|--|
| LUT3_9 or Counter5 Select | reg<1194> | 0: LUT3_9 1: Counter6 |
| Delay6 Mode Select or asynchronous counter reset | reg<1305:1304> | 00: on both falling and rising edges (for delay & counter reset) 01: on falling edge only (for delay & counter reset) 10: on rising edge only (for delay & counter reset) 11: no delay on either falling or rising edges / counter high level reset |
| Counter/delay6 Clock Source Select | reg<1308:1306> | 000: Internal OSC clock 001: OSC/4 010: OSC/12 011: OSC/24 100: OSC/64 101: 25 MHz OSC clock 110: External Clock 111: Counter5 Overflow |
| Counter/delay6 Output Selection for Counter mode | reg<1309> | 0: Default Output 1: Edge Detector Output |
| Counter/delay6 Mode Selection | reg<1311:1310> | 00: Delay mode 01: One Shot 10: Freq. Detect 11: Counter mode |
| Counter/delay6 Control Data | reg<1575:1568> | 1 – 255 |

9.7 4-Bit LUT or 16-Bit Counter / Delay Macrocells

There are two macrocells that can serve as either 4-bit LUTs or as 16-bit Counter / Delays. When used to implement LUT function, the 4-bit LUT takes in four input signals from the Connection Matrix and produces a single output, which goes back into the Connection Matrix. When used to implement 16-Bit Counter / Delay function, four input signals from the connection matrix go to the external clock (ext_clk), reset (DLY_in/CNT_Reset), Keep and Up for the counter/delay, with the output going back to the connection matrix.

These two macrocells have an optional Finite State Machine (FSM) function. There are two matrix inputs for Up and Keep to support FSM functionality. Any counter within Green PAK is counting down by default. In FSM mode (CNT/DLY0 and CNT/DLY1) it is possible to reverse counting by applying High level to Up input. Also, there is a possibility to pause counting by applying High level to Keep input, after the level goes Low, the counter will proceed counting.

These macrocells can also operate in a one-shot mode, which will generate an output pulse of user-defined width.

These macrocells can also operate in a frequency detection.

Delay time and Output Period can be calculated using the following formulas:

- Delay time: $[(\text{Counter data} + 2) / \text{CLK input frequency} - \text{Offset}^*]$;
- Output Period: $[(\text{Counter data} + 1) / \text{CLK input frequency} - \text{Offset}^*]$.

One Shot pulse width can be calculated using formula:

- Pulse width = $[(\text{Counter Data} + 2) / \text{CLK input frequency} - \text{Offset}^*]$;

*Offset is the asynchronous time offset between the input signal and the first clock pulse.

For timing diagrams refer to section 9.8 *CNT/DLY/FSM Timing Diagrams*.

Note: Counters initialize with counter data after POR

Both of these macrocells can have their active count value read via I²C. See Section 19.5.1.2 *Reading Counter Data via I2C* for further details.

9.7.1 4-Bit LUT or 16-Bit CNT/DLY Block Diagram

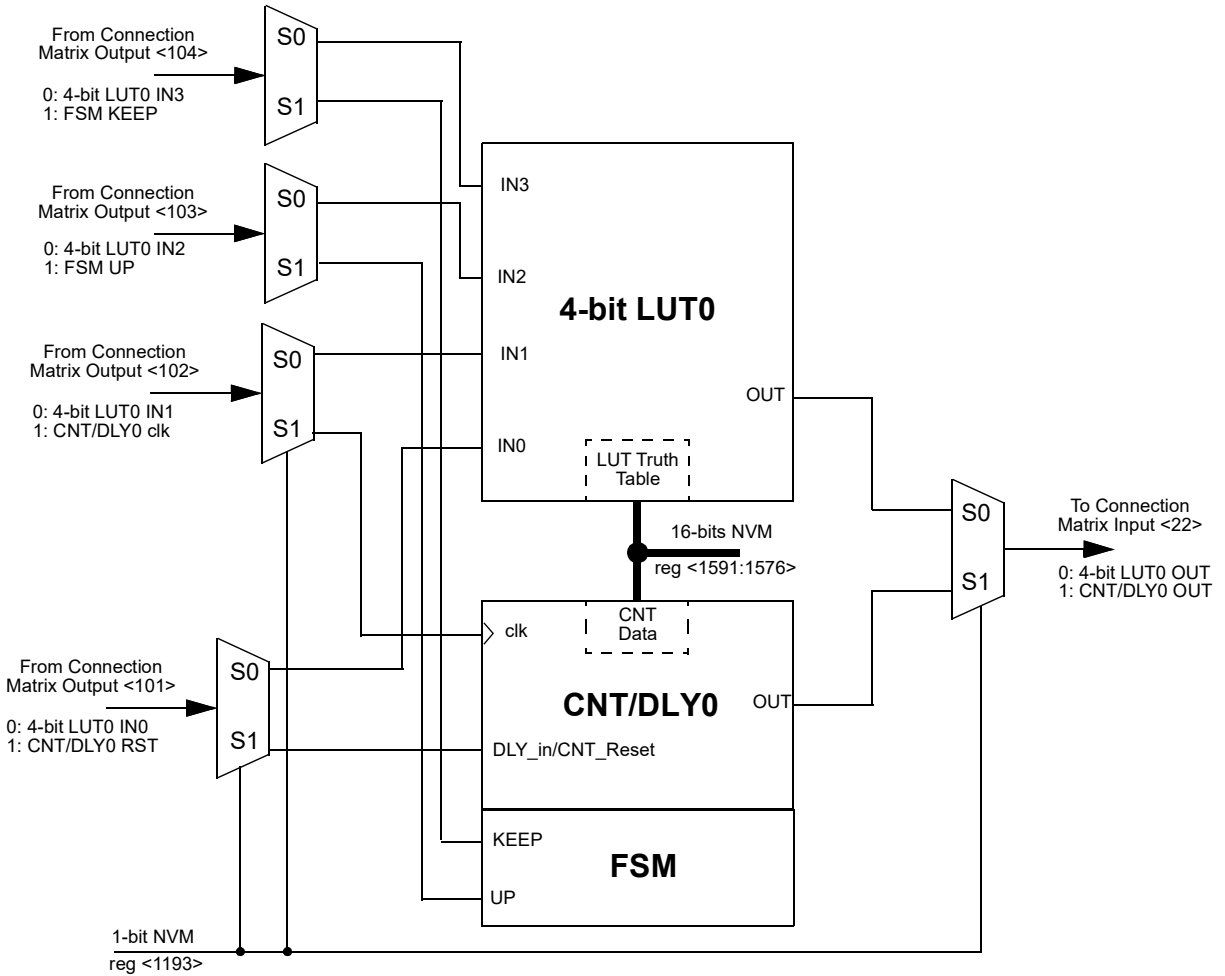

Figure 34. 4-bit LUT0 or CNT/DLY0

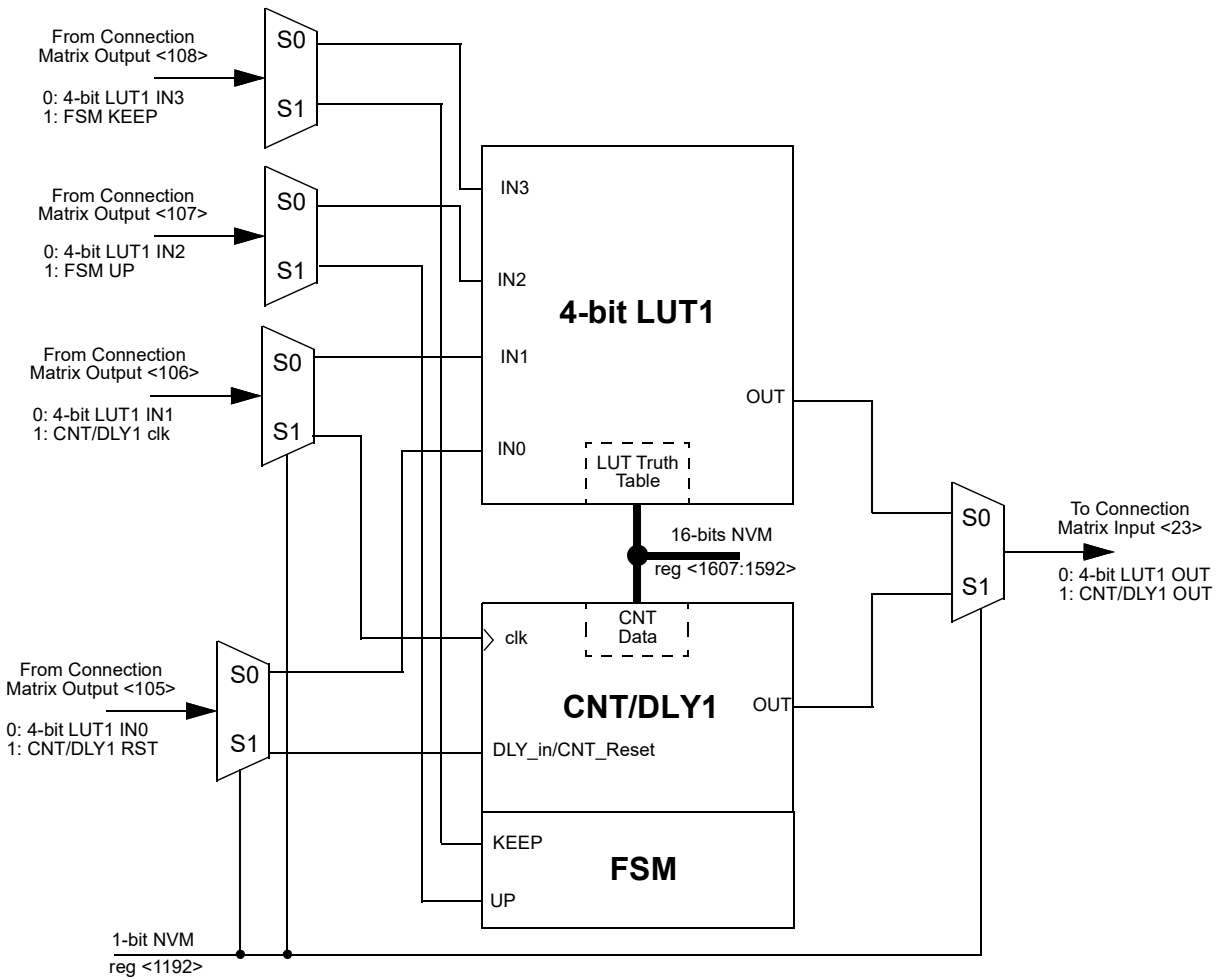

Figure 35. 4-bit LUT1 or CNT/DLY1

9.7.2 4-Bit LUT or 16-Bit Counter / Delay Macrocells Used as 4-Bit LUTs

Table 67. 4-bit LUT0 Truth Table.

| IN3 | IN2 | IN1 | IN0 | OUT | |
|-----|-----|-----|-----|------------|-----|
| 0 | 0 | 0 | 0 | reg <1576> | LSB |
| 0 | 0 | 0 | 1 | reg <1577> | |
| 0 | 0 | 1 | 0 | reg <1578> | |
| 0 | 0 | 1 | 1 | reg <1579> | |
| 0 | 1 | 0 | 0 | reg <1580> | |
| 0 | 1 | 0 | 1 | reg <1581> | |
| 0 | 1 | 1 | 0 | reg <1582> | |
| 0 | 1 | 1 | 1 | reg <1583> | |
| 1 | 0 | 0 | 0 | reg <1584> | |
| 1 | 0 | 0 | 1 | reg <1585> | |
| 1 | 0 | 1 | 0 | reg <1586> | |
| 1 | 0 | 1 | 1 | reg <1587> | |
| 1 | 1 | 0 | 0 | reg <1588> | |
| 1 | 1 | 0 | 1 | reg <1589> | |
| 1 | 1 | 1 | 0 | reg <1590> | |
| 1 | 1 | 1 | 1 | reg <1591> | MSB |

Table 68. 4-bit LUT1 Truth Table.

| IN3 | IN2 | IN1 | IN0 | OUT | |
|-----|-----|-----|-----|------------|-----|
| 0 | 0 | 0 | 0 | reg <1592> | LSB |
| 0 | 0 | 0 | 1 | reg <1593> | |
| 0 | 0 | 1 | 0 | reg <1594> | |
| 0 | 0 | 1 | 1 | reg <1595> | |
| 0 | 1 | 0 | 0 | reg <1596> | |
| 0 | 1 | 0 | 1 | reg <1597> | |
| 0 | 1 | 1 | 0 | reg <1598> | |
| 0 | 1 | 1 | 1 | reg <1599> | |
| 1 | 0 | 0 | 0 | reg <1600> | |
| 1 | 0 | 0 | 1 | reg <1601> | |
| 1 | 0 | 1 | 0 | reg <1602> | |
| 1 | 0 | 1 | 1 | reg <1603> | |
| 1 | 1 | 0 | 0 | reg <1604> | |
| 1 | 1 | 0 | 1 | reg <1605> | |
| 1 | 1 | 1 | 0 | reg <1606> | |
| 1 | 1 | 1 | 1 | reg <1607> | MSB |

Each Macrocell, when programmed for a LUT function, uses a 16-bit register to define their output function:

4-Bit LUT0 is defined by reg<1591:1576>

4-Bit LUT1 is defined by reg<1607:1592>

Table 69. 4-bit LUT Standard Digital Functions

| Function | MSB | | | | | | | | | | | | | | | LSB |
|----------|-----|---|---|---|---|---|---|---|---|---|---|---|---|---|---|-----|
| AND-4 | 1 | 0 | 0 | 0 | 0 | 0 | 0 | 0 | 0 | 0 | 0 | 0 | 0 | 0 | 0 | 0 |
| NAND-4 | 0 | 1 | 1 | 1 | 1 | 1 | 1 | 1 | 1 | 1 | 1 | 1 | 1 | 1 | 1 | 1 |
| OR-4 | 1 | 1 | 1 | 1 | 1 | 1 | 1 | 1 | 1 | 1 | 1 | 1 | 1 | 1 | 1 | 0 |
| NOR-4 | 0 | 0 | 0 | 0 | 0 | 0 | 0 | 0 | 0 | 0 | 0 | 0 | 0 | 0 | 0 | 1 |
| XOR-4 | 0 | 1 | 1 | 0 | 1 | 0 | 0 | 1 | 1 | 0 | 0 | 1 | 0 | 1 | 1 | 0 |
| XNOR-4 | 1 | 0 | 0 | 1 | 0 | 1 | 1 | 0 | 0 | 1 | 1 | 0 | 1 | 0 | 0 | 1 |

9.7.3 4-Bit LUT or 16-Bit Counter / Delay Macrocells Used as 16-Bit Counter / Delay Register Settings
Table 70. CNT/DLY0 Register Settings

| Signal Function | Register Bit Address | Register Definition |
|--|----------------------|--|
| LUT4_0 or Counter0 Select | reg<1193> | 0: LUT4_0 1: Counter0 |
| Delay0 Mode Select or asynchronous counter reset | reg<1313:1312> | 00: on both falling and rising edges (for delay & counter reset) 01: on falling edge only (for delay & counter reset) 10: on rising edge only (for delay & counter reset) 11: no delay on either falling or rising edges / counter high level reset |
| Counter/delay0 Clock Source Select | reg<1316:1314> | 000: Internal OSC clock 001: OSC/4 010: OSC/12 011: OSC/24 100: OSC/64 101: 25 MHz OSC clock 110: External Clock 111: Counter6 Overflow |
| CNT0/FSM0's Q are Set to data or Reset to 0s Selection | reg<1317> | 0: Reset to 0s 1: Set to control data |
| Counter/delay0 Mode Selection | reg<1319:1318> | 00: Delay mode 01: One Shot 10: Freq. Detect 11: Counter mode |
| Counter/delay0 Control Data | reg<1591:1576> | 1 - 65535 |

Table 71. CNT/DLY1 Register Settings

| Signal Function | Register Bit Address | Register Definition |
|--|----------------------|--|
| LUT4_1 or Counter1 Select | reg<1192> | 0: LUT4_1 1: Counter1 |
| Delay1 Mode Select or asynchronous counter reset | reg<1321:1320> | 00: on both falling and rising edges (for delay & counter reset) 01: on falling edge only (for delay & counter reset) 10: on rising edge only (for delay & counter reset) 11: no delay on either falling or rising edges / counter high level reset |
| Counter/delay1 Clock Source Select | reg<1324:1322> | 000: Internal OSC clock 001: OSC/4 010: OSC/12 011: OSC/24 100: OSC/64 101: 25 MHz OSC clock 110: External Clock 111: Counter0 Overflow |
| CNT0/FSM0's Q are Set to data or Reset to 0s Selection | reg<1325> | 0: Reset to 0s 1: Set to control data |
| Counter/delay1 Mode Selection | reg<1327:1326> | 00: Delay mode 01: One Shot 10: Freq. Detect 11: Counter mode |
| Counter/delay1 Control Data | reg<1607:1592> | 1 - 65535 |

9.8 CNT/DLY/FSM Timing Diagrams

9.8.1 Delay mode (edge select: both, counter data: 3) CNT/DLY2...CNT/DLY6

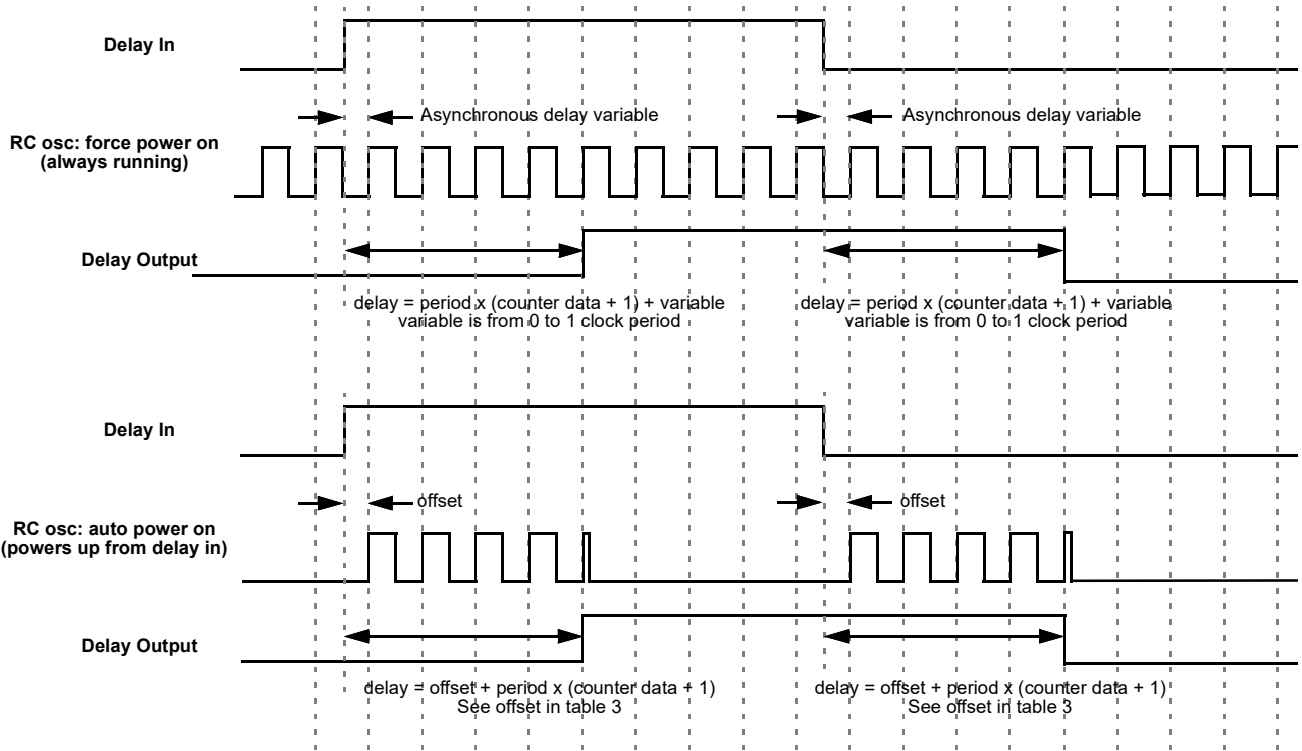

Figure 36. Delay Mode Timing Diagram

9.8.2 Count mode (count data: 3), Counter reset (rising edge detect) CNT/DLY2...CNT/DLY6

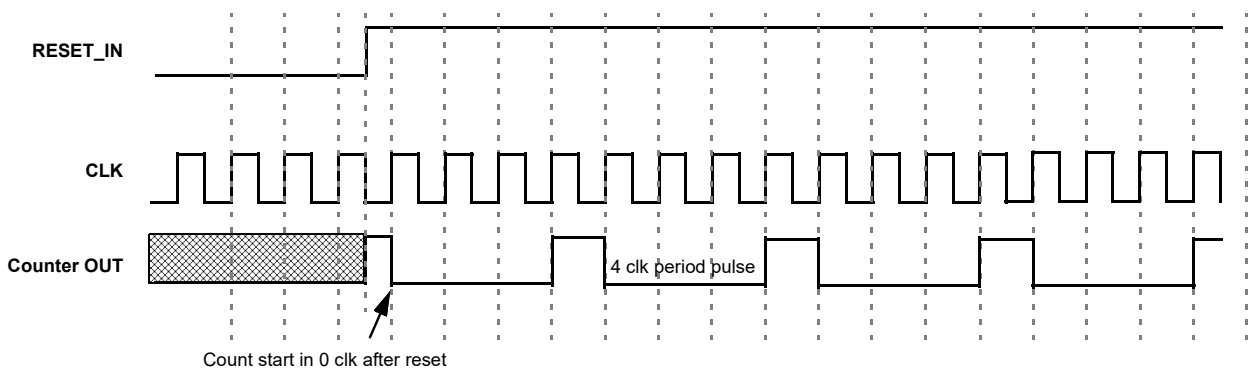

Figure 37. Counter Mode Timing Diagram

9.8.3 One-shot mode CNT/DLY0...CNT/DLY6

This macrocell will generate a pulse whenever a selected edge is detected on its input. Register bits set the edge selection. The pulse width determines by counter data and clock selection properties. The output pulse polarity (non-inverted or inverted) is selected by register bit. See *Table 72*. Any incoming edges will be ignored during the pulse width generation. The following diagram shows one-shot function for non-inverted output.

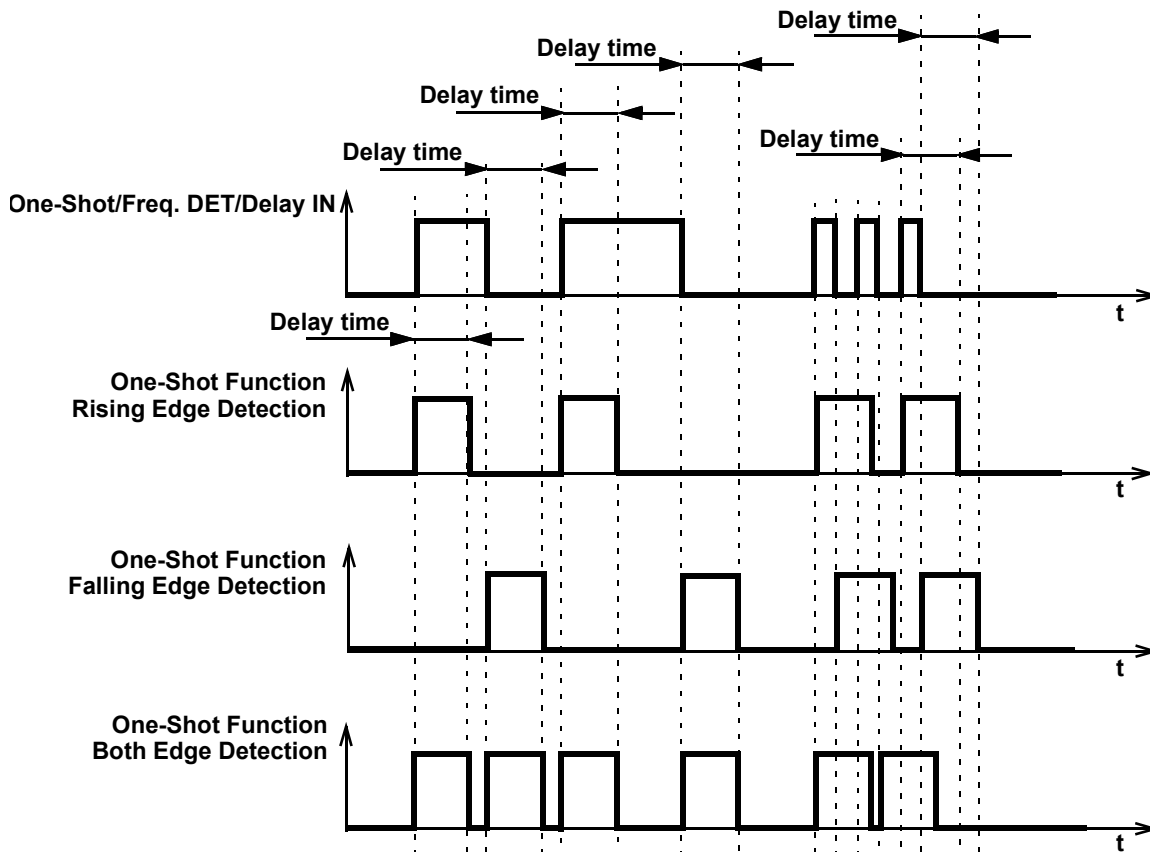

Figure 38. One-Shot Function Timing Diagram

Table 72. DLY/CNTx One-Shot / Freq. Detect Output Polarity

| Address | | Signal Function | Register Bit Definition | I ² C Interface | |
|---------|--------------|--|---|----------------------------|-------|
| Byte | Register Bit | | | Read | Write |
| A6 | reg<1329> | Select the Polarity of DLY/CNT6's One Shot / Freq. Detect Output | 0: Default Output 1: Inverted Output | Valid | Valid |
| | reg<1330> | Select the Polarity of DLY/CNT5's One Shot / Freq. Detect Output | 0: Default Output 1: Inverted Output | Valid | Valid |
| | reg<1331> | Select the Polarity of DLY/CNT4's One Shot / Freq. Detect Output | 0: Default Output 1: Inverted Output | Valid | Valid |
| | reg<1332> | Select the Polarity of DLY/CNT3's One Shot / Freq. Detect Output | 0: Default Output 1: Inverted Output | Valid | Valid |
| | reg<1333> | Select the Polarity of DLY/CNT2's One Shot / Freq. Detect Output | 0: Default Output 1: Inverted Output | Valid | Valid |
| | reg<1334> | Select the Polarity of DLY/CNT1's One Shot / Freq. Detect Output | 0: Default Output 1: Inverted Output | Valid | Valid |
| | reg<1335> | Select the Polarity of DLY/CNT0's One Shot / Freq. Detect Output | 0: Default Output 1: Inverted Output | Valid | Valid |

This macrocell generates a high level pulse with a set width (defined by counter data) when detecting the respective edge. It does not restart while pulse is high.

9.8.4 Frequency Detection Mode CNT/DLY0...CNT/DLY6

Rising Edge: The output goes high if the time between two successive edges is less than the delay. The output goes low if the second rising edge has not come after the last rising edge in specified time.

Falling Edge: The output goes high if the time between two falling edges is less than the set time. The output goes low if the second falling edge has not come after the last falling edge in specified time.

Both Edge: The output goes high if the time between the rising and falling edges is less than the set time, which is equivalent to the length of the pulse. The output goes low if after the last rising/falling edge and specified time, the second edge has not come.

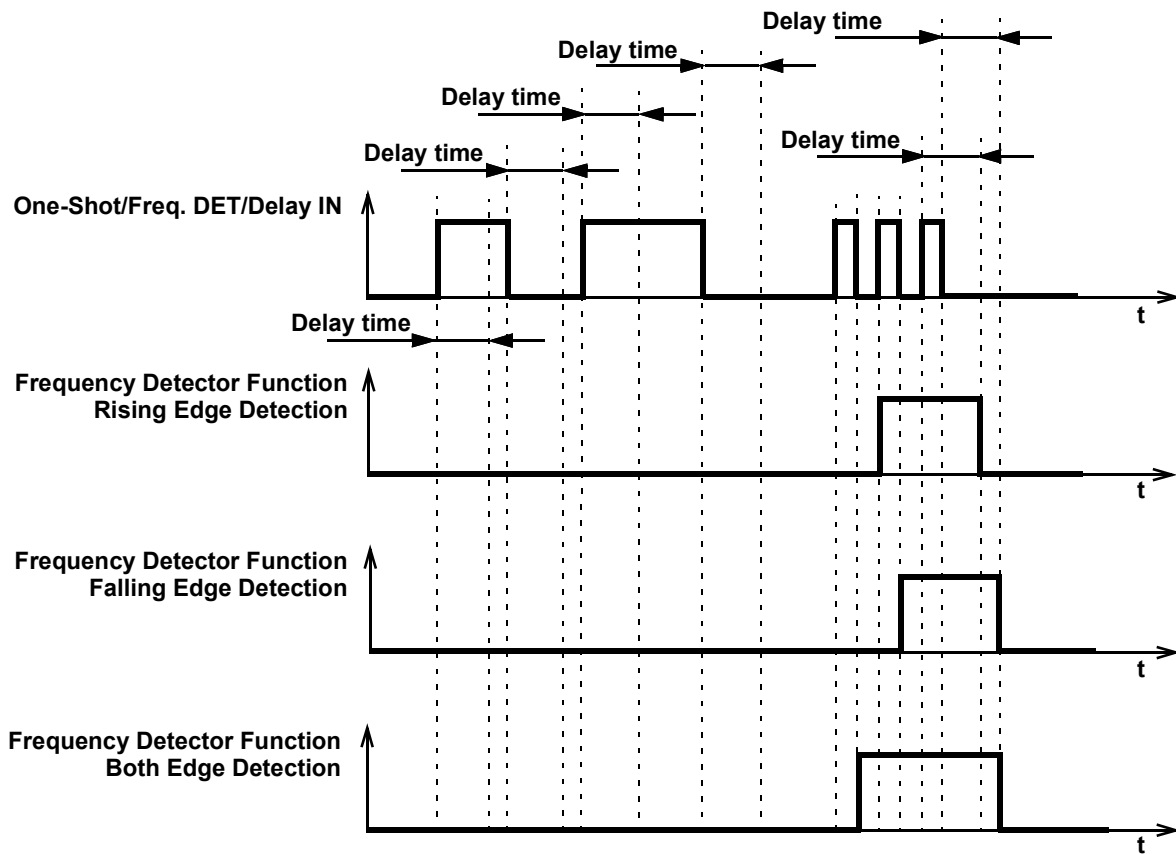

Figure 39. Frequency Detection Mode Timing Diagram

9.8.5 Edge Detection Mode CNT/DLY2...CNT/DLY6

The macrocell generates high level short pulse when detecting the respective edge. See Table 5. *Expected Delays and Widths (typical)*.

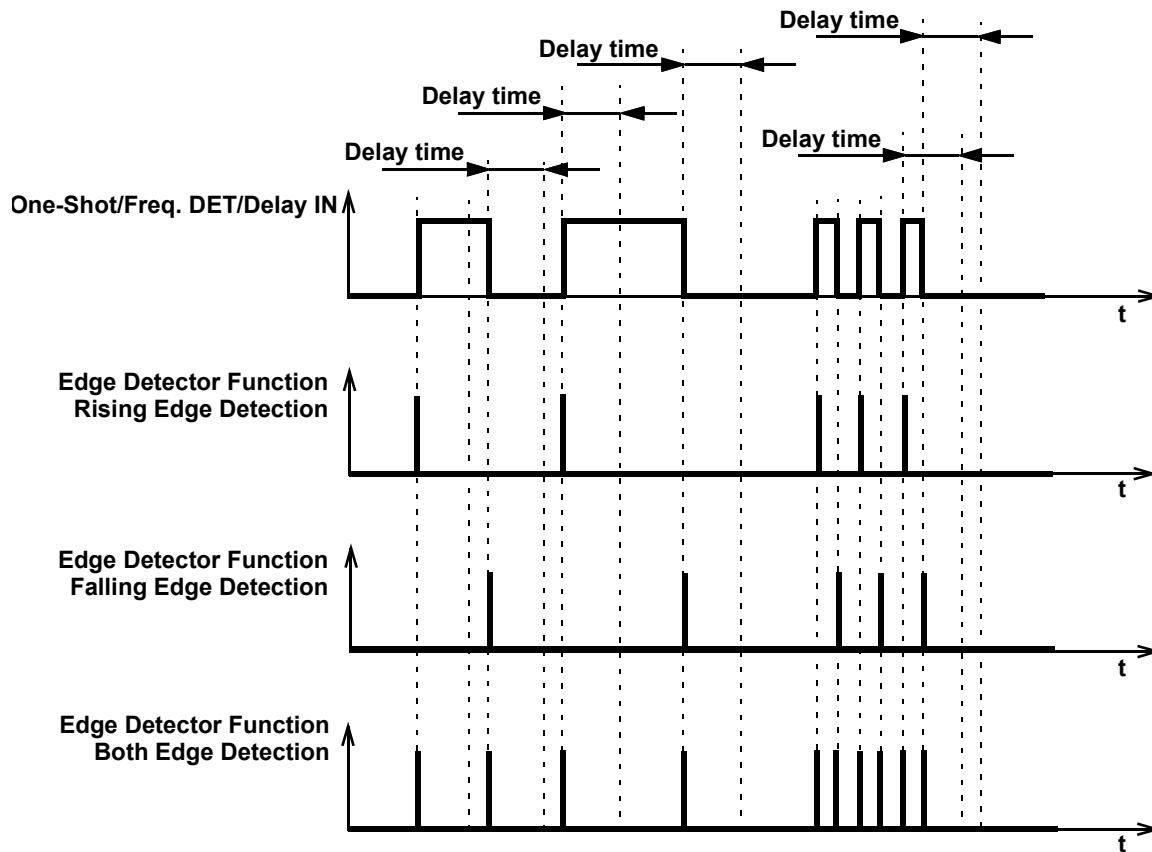

Figure 40. Edge Detection Mode Timing Diagram

9.8.6 Delay Mode CNT/DLY0...CNT/DLY6

The macrocell shifts the respective edge to a set time and restarts by appropriate edge. It works as a filter if the input signal is shorter than the delay time.

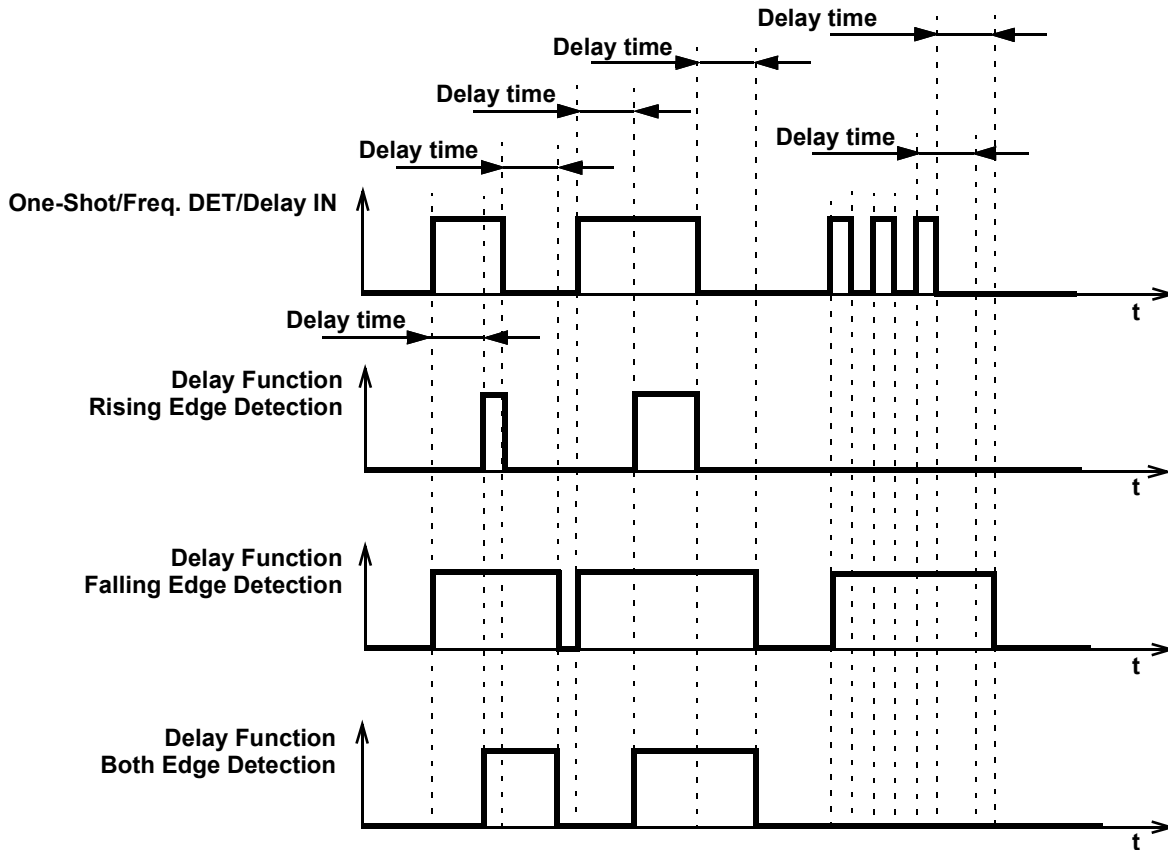

Figure 41. Delay Mode Timing Diagram

9.8.7 CNT/FSM Mode CNT/DLY0, CNT/DLY1

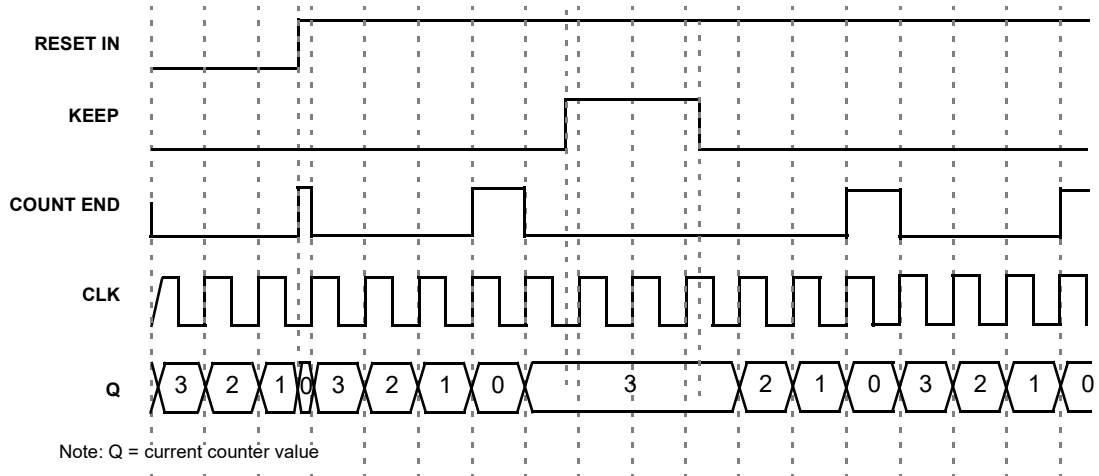

Figure 42. CNT/FSM Timing Diagram (reset rising edge mode, oscillator is forced on, UP = 0) for counter data = 3

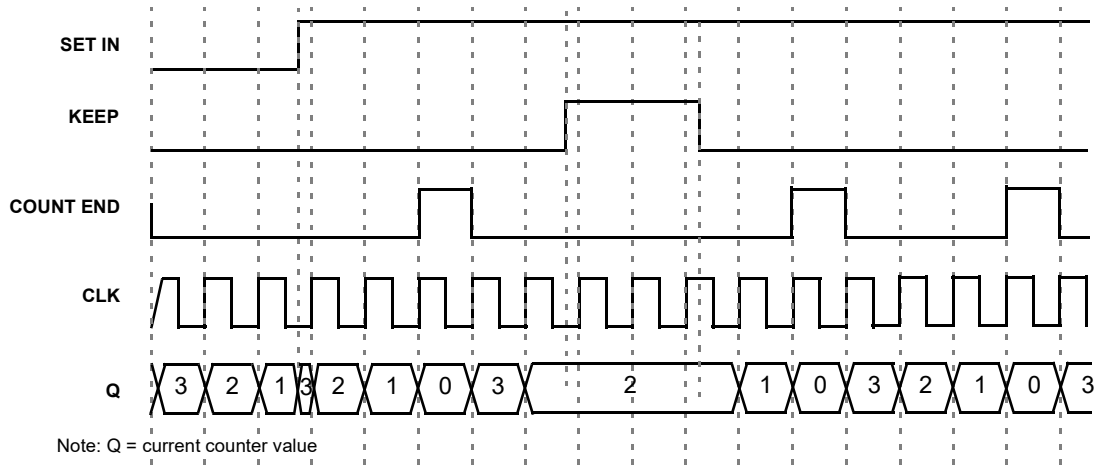

Figure 43. CNT/FSM Timing Diagram (set rising edge mode, oscillator is forced on, UP = 0) for counter data = 3

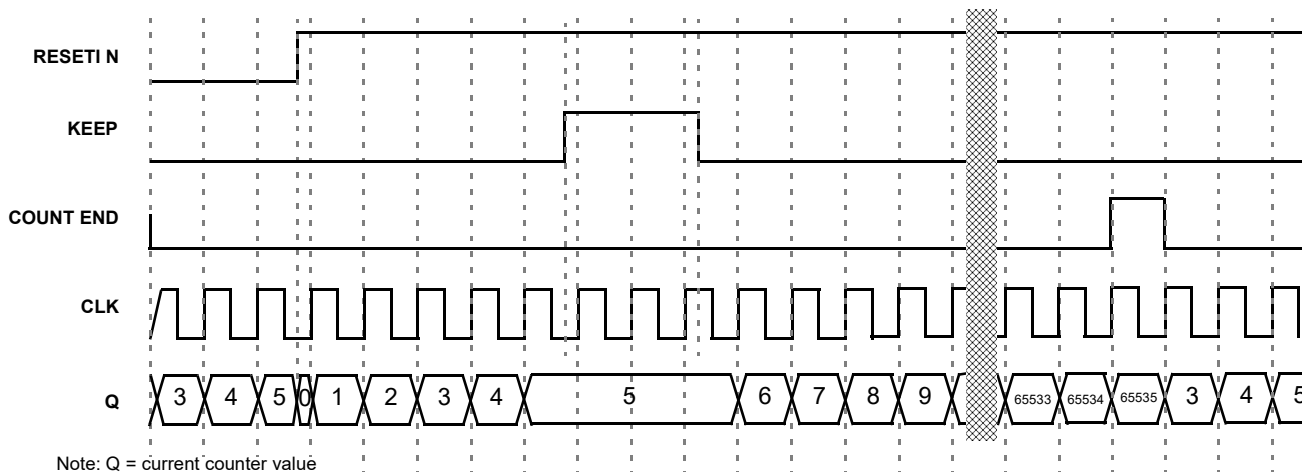

Figure 44. CNT/FSM Timing Diagram (reset rising edge mode, oscillator is forced on, UP = 1) for counter data = 3

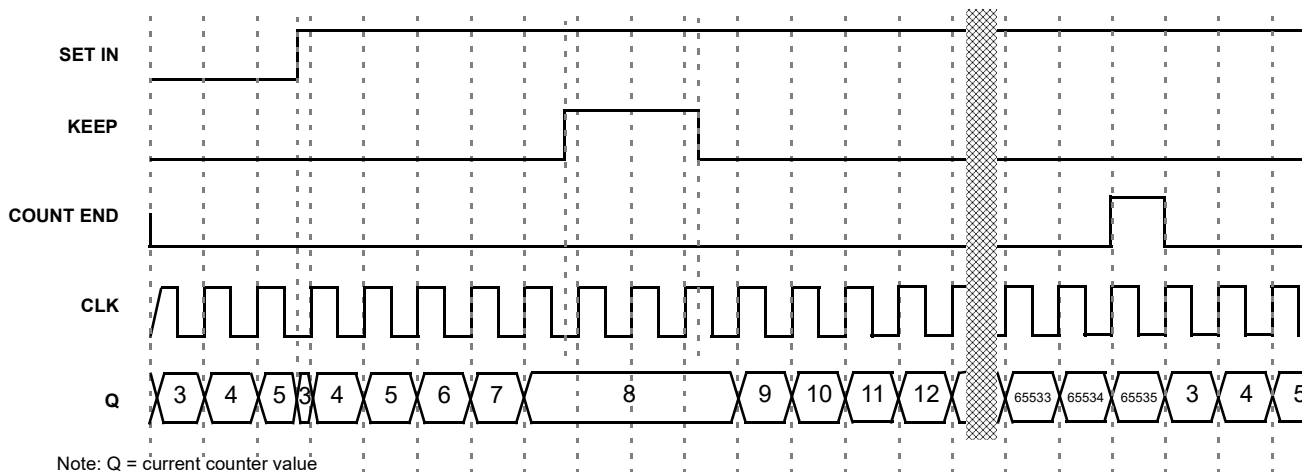

Figure 45. CNT/FSM Timing Diagram (set rising edge mode, oscillator is forced on, UP = 1) for counter data = 3

9.8.8 Difference in Counter Value for Counter, Delay, One-Shot and Frequency Detect Modes

There is a difference in counter value for Counter and Delay/One-Shot/Frequency Detect modes. The counter value is shifted for two rising edges of the clock signal in Delay/One-Shot/Frequency Detect modes compared to Counter mode. See Figure 46.

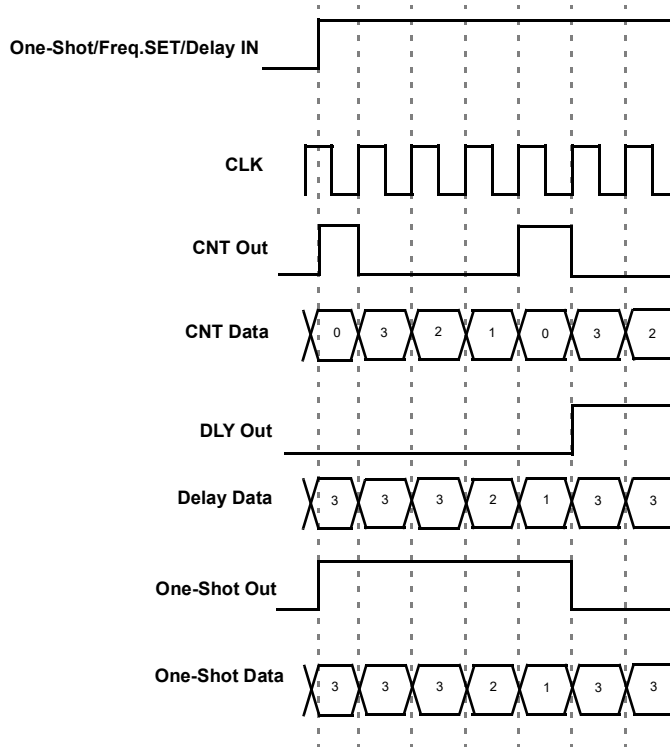

Figure 46. Counter Value, Counter Data = 3

9.9 2-bit LUT or Programmable Pattern Generator

The SLG46534 has one combination function macrocell that can serve as a logic or timing function. This macrocell can serve as a Look Up Table (LUT), or Programmable Pattern Generator (PGEN).

When used to implement LUT functions, the 2-bit LUT takes in two input signals from the connection matrix and produce a single output, which goes back into the connection matrix. When used as a LUT to implement combinatorial logic functions, the outputs of the LUTs can be configured to any user defined function, including the following standard digital logic devices (AND, NAND, OR, NOR, XOR, XNOR). The user can also define the combinatorial relationship between inputs and outputs to be any selectable function.

When operating as a Programmable Pattern Generator, the output of the macrocell with clock out a sequence of two to sixteen bits that are user selectable in their bit values, and user selectable in the number of bits (up to sixteen) that are output before the pattern repeats. See figure Figure 48.

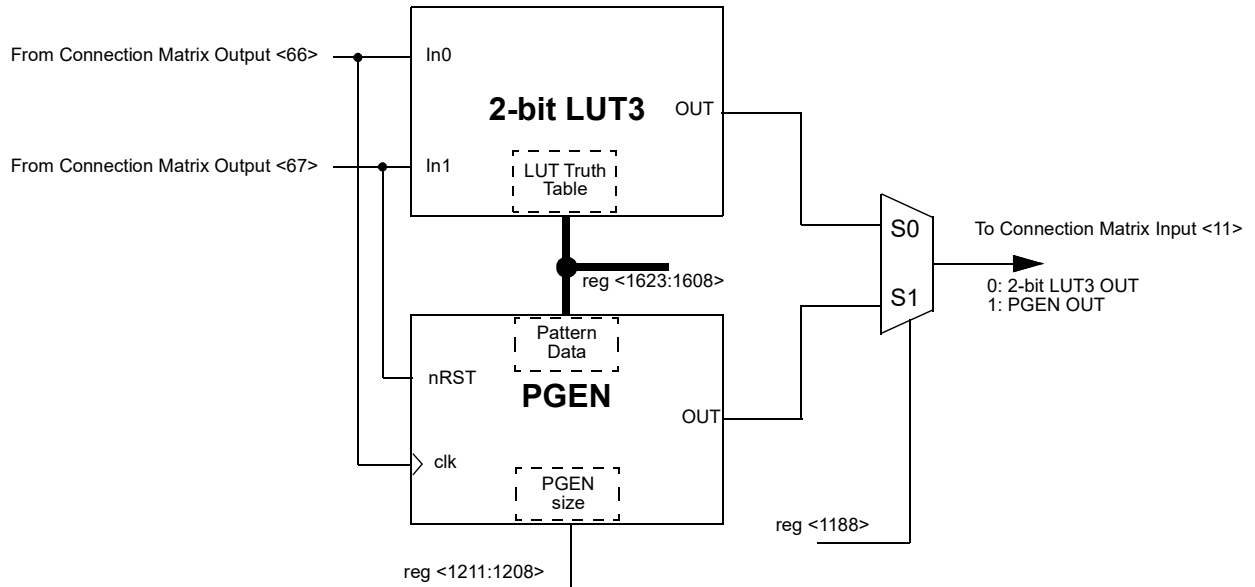

Figure 47. 2-bit LUT2 or PGEN

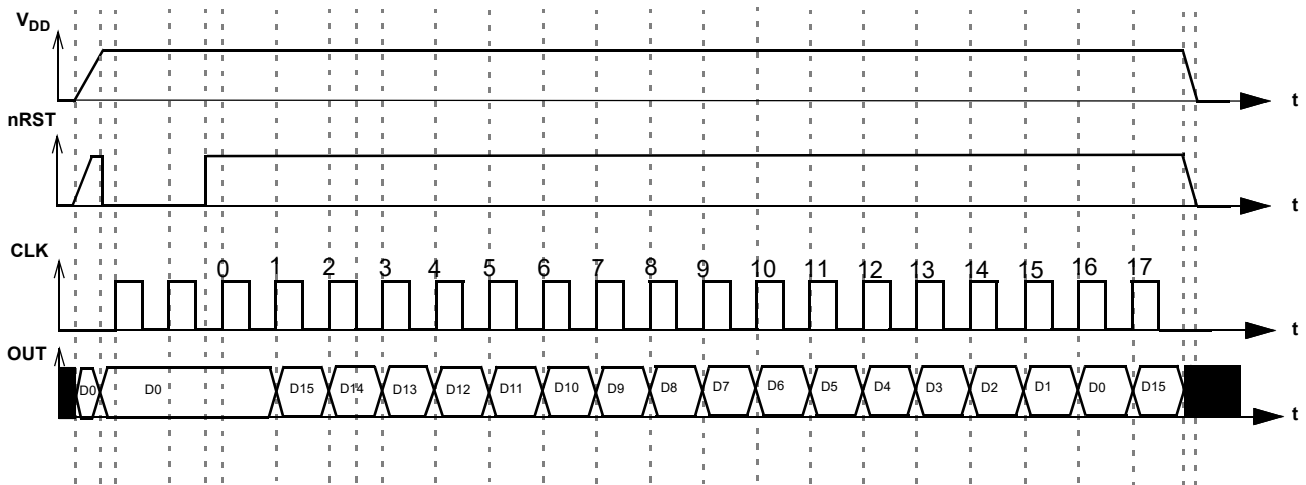
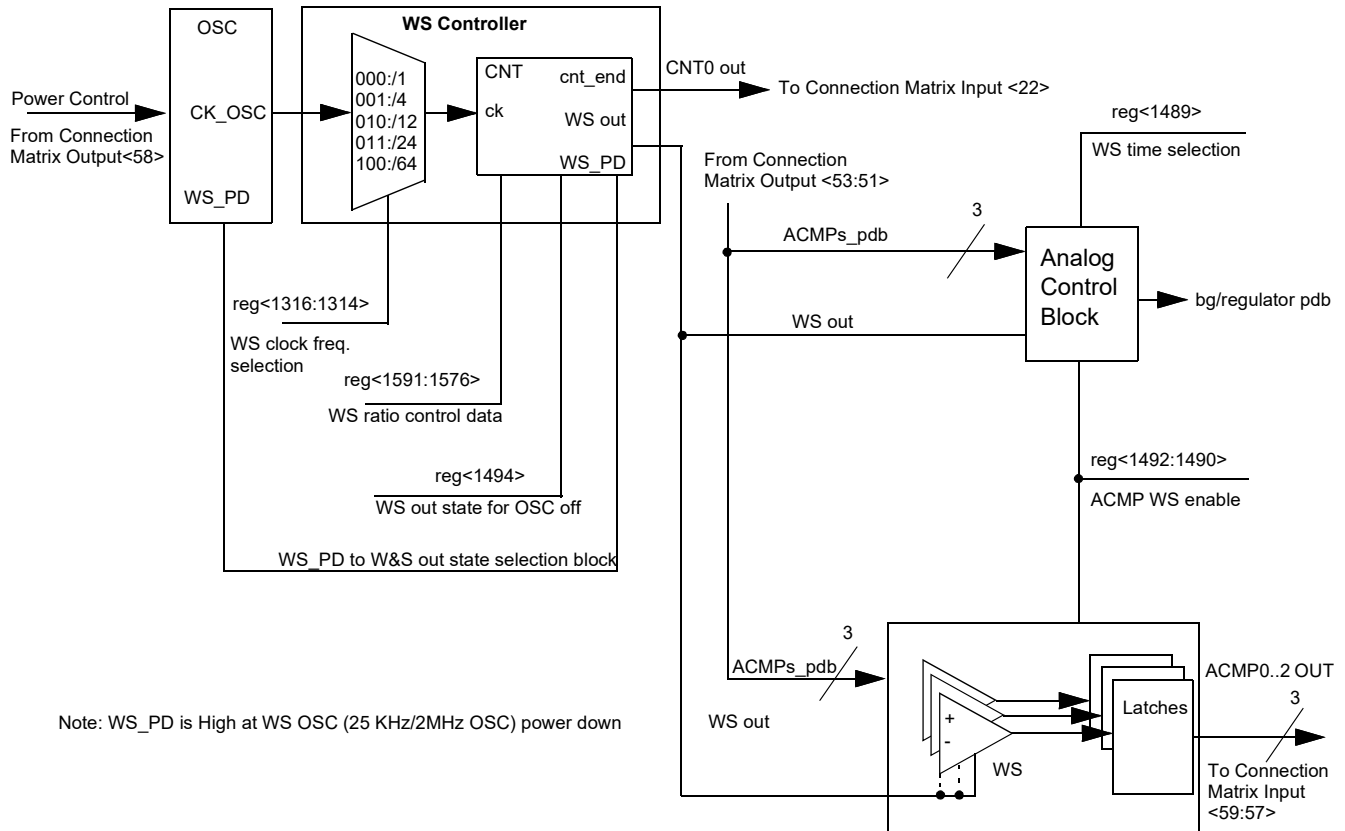

Figure 48. PGEN Timing Diagram

9.10 Wake and Sleep controller (WS)

The SLG46534 has a Wake and Sleep function for all ACMPs. The macrocell CNT/DLY0 can be reconfigured for this purpose reg<1319:1318> = 11 and reg<1495> = 1. The WS serves for power saving, it allows to switch on and off selected ACMPs on selected bit of 16-bit counter.



Note: WS_PD is High at WS OSC (25 KHz/2MHz OSC) power down

Figure 49. WS controller

To use any ACMP under WS controller the following settings must be done:

- ACMP Power Up Input from matrix = 1 (for each ACMP separately);
- CNT/DLY0 must be set to Wake and Sleep Controller function (for all ACMPs);
- Register WS => enable (for each ACMP separately);
- CNT/DLY0 set/reset input = 0 (for all ACMPs);
- In case of using OSC1 (25 MHz), OSC0 must be set to Force Power On.

As the OSC any oscillator with any pre divider can be used. The user can select a period of time while the ACMPs are sleeping in a range of 1 - 65535 clock cycles. Before they are sent to sleep their outputs are latched so the ACMPs remain their state (High or Low) while sleeping.

WS controller has the following settings:

- Wake and Sleep Output State (High/Low)
If OSC is powered off (Power Down option is selected; power down input = 1) and Wake and Sleep Output State = High, the ACMP is continuously on.

If OSC is powered off (Power Down option is selected; power down input = 1) and Wake and Sleep Output State = Low, the ACMP is continuously off.
Both cases WS function is turned off.

- Counter Data (Range: 1 - 65535)
User can select wake and sleep ratio of the ACMP; counter data = sleep time, one clock = wake time.
- Q mode - defines the state of WS counter data when Set/Reset signal appears
Reset - when active signal appears, the WS counter will reset to zero and High level signal on its output will turn the ACMPs on. When Reset signal goes out, the WS counter will go Low and turn the ACMPs off until the counter counts up to the end
Set - when active signal appears, the WS counter will stop and Low level signal on its output will turn the ACMPs off. When Set signal goes out, the WS counter will go on counting and High level signal will turn the ACMPs on while counter is counting up to the end.
- Edge Select defines the edge for Q mode
High level Set/Reset - switches mode Set/Reset when level is High
Note: Q mode operates only in case of "High Level Set/Reset".
- Wake time selection - time required for wake signal to turn the ACMPs on
Normal Wake Time - when WS signal is High, it takes a BG time (100/550 μ s) to turn the ACMPs on They will stay on until WS signal is Low again. Wake time is one clock period. It should be longer than BG turn on time and minimal required comparing time of the ACMP.
Short Wake Time - when WS signal is High, it takes a BG time (100/550 μ s) to turn the ACMPs on. They will stay on for 1 μ s and turn off regardless of WS signal. The WS signal width does not matter.
- Keep - pauses counting while Keep = 1
- Up - reverses counting
If Up = 1, CNT is counting up from user selected value to 65535.
If Up = 0, CNT is counting down from user selected value to 0.

9.10.1 WS Register Settings
Table 73. WS Register Settings

| Signal Function | Register Bit Address | Register Definition |
|---|----------------------|--|
| Counter/delay0 Clock Source Select | reg<1316:1314> | 000: Internal OSC clock 001: OSC/4 010: OSC/12 011: OSC/24 100: OSC/64 101: 25 MHz OSC clock 110: External Clock 111: Counter6 Overflow |
| WS time selection | reg<1489> | 0: Short Wake Time 1: Normal Wake Time |
| ACMP0 Wake & Sleep function Enable | reg<1490> | 0: Disable 1: Enable |
| ACMP1 Wake & Sleep function Enable | reg<1491> | 0: Disable 1: Enable |
| ACMP2 Wake & Sleep function Enable | reg<1492> | 0: Disable 1: Enable |
| Wake Sleep Output State When WS Oscillator is Power Down if DLY/CNT0 Mode Selection is "11" | reg<1494> | 0: Low 1: High |
| Wake Sleep Ratio Control Mode Selection if DLY/CNT0 Mode Selection is "11" | reg<1495> | 0: Default Mode 1: Wake Sleep Ratio Control Mode |
| DLY/CNT0 (16bits, <15:0> = <1591:1576>) Control Data | reg<1591:1576> | 1 - 65535 |

10.0 Analog Comparators (ACMP)

There are three Analog Comparator (ACMP) macrocells in the SLG46534. In order for the ACMP cells to be used in a GreenPAK design, the power up signals (ACMPx_pdb) need to be active. By connecting to signals coming from the Connection Matrix, it is possible to have each ACMP be always on, always off, or power cycled based on a digital signal coming from the Connection Matrix. Also, all ACMPs have Wake and Sleep function (WS), see section 9.10 Wake and Sleep controller (WS). When ACMP is powered down, output is low.

PWR UP = 1 => ACMP is powered up.
 PWR UP = 0 => ACMP is powered down.

During ACMP power up, its output will remain low, and then becomes valid 1.03 ms (max) after ACMP power up signal goes high, see Figure 51. . If V_{DD} is greater or equal to 2.7 V, it is possible to decrease turn-on time by setting the BG ok delay to 100 μs, see Figure 52. . The ACMP cells have an input "Low bandwidth" signal selection, which can be used to save power and reduce noise impact when lower bandwidth signals are being compared. To ensure proper chip startup operation, it is recommended to enable the ACMPs with the POR signal, and not the V_{DD} signal.

Note: Regulator and Charge Pump set to automatic ON/OFF.

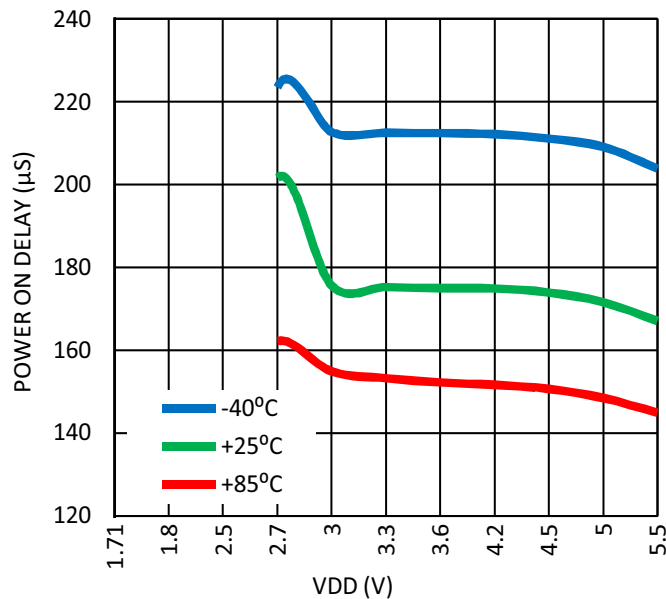

Figure 50. Maximum Power On Delay vs. V_{DD}, BG = Auto-delay.

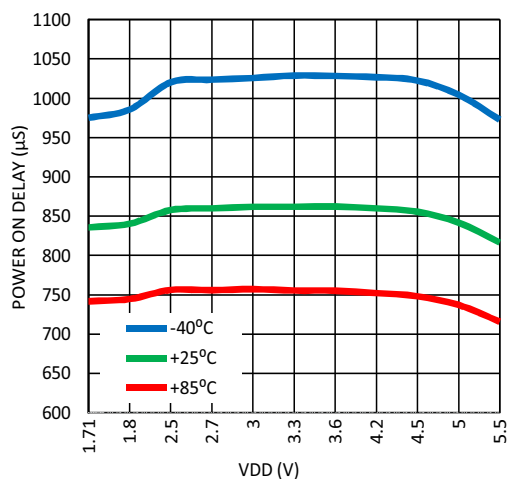

Figure 51. Maximum Power On Delay vs. VDD, BG = 550 μs.

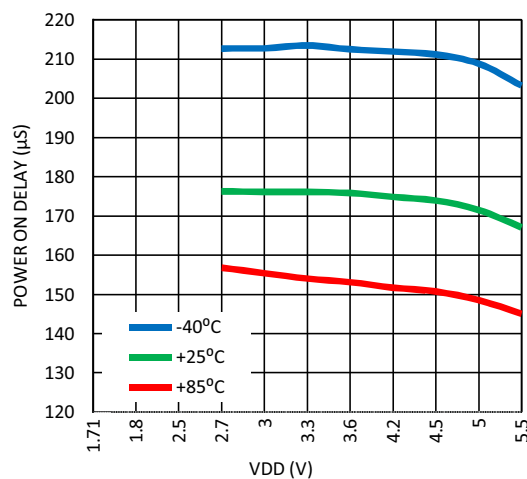

Figure 52. Maximum Power On Delay vs. VDD, BG = 100 μs.

Each of the ACMP cells has a positive input signal that can be provided by a variety of external sources. There is also a selectable gain stage (1X, 0.5X, 0.33X, 0.25X) before connection to the analog comparator. The Gain divider is unbuffered and consists of 250 KΩ (typ.) resistors, see *Table 74*. For gain divider accuracy refer to *Table 75*. IN- voltage range: 0 - 1.2 V. Can use Vref selection $V_{DD}/4$ and $V_{DD}/3$ to maintain this input range.

Input bias current < 1 nA (typ).

Table 74. Gain Divider Input Resistance

| | | | | |
|------------------|--------|------|---------|-------|
| Gain | x1 | x0.5 | x0.33 | x0.25 |
| Input Resistance | 100 MΩ | 1 MΩ | 0.75 MΩ | 1 MΩ |

Table 75. Gain Divider Accuracy

| | | | |
|----------|--------|--------|--------|
| Gain | x0.5 | x0.33 | x0.25 |
| Accuracy | ±0.51% | ±0.34% | ±0.25% |

Each cell also has a hysteresis selection, to offer hysteresis of 0 mV, 25 mV, 50 mV or 200 mV. The 50 mV and 200 mV hysteresis options can be used with internal voltage reference only, while 25 mV hysteresis option can be used with both internal and external voltage reference. The 50 mV and 200 mV hysteresis options are one way hysteresis. It means that the actual thresholds will be Vref (high threshold) and Vref - hysteresis (low threshold). The ACMP output will retain its previous value, if the input voltage is within threshold window (between Vref and Vref - hysteresis). Please note: for the 25 mV hysteresis option threshold levels will be Vref + hysteresis/2 (high threshold) and Vref – hysteresis/2 (low threshold).

Note: Any ACMP powered on enables the BandGap internal circuit as well. An analog voltage will appear on Vref even when the Force BandGap option is set as Disabled.

For high input impedance when using the gain divider (x0.25, x0.33, x0.5), it is possible to use the input buffer. However, this will add some offset, see Figure 53. . It is not recommended to use ACMP buffer when V_{DD} < 2.5 V.

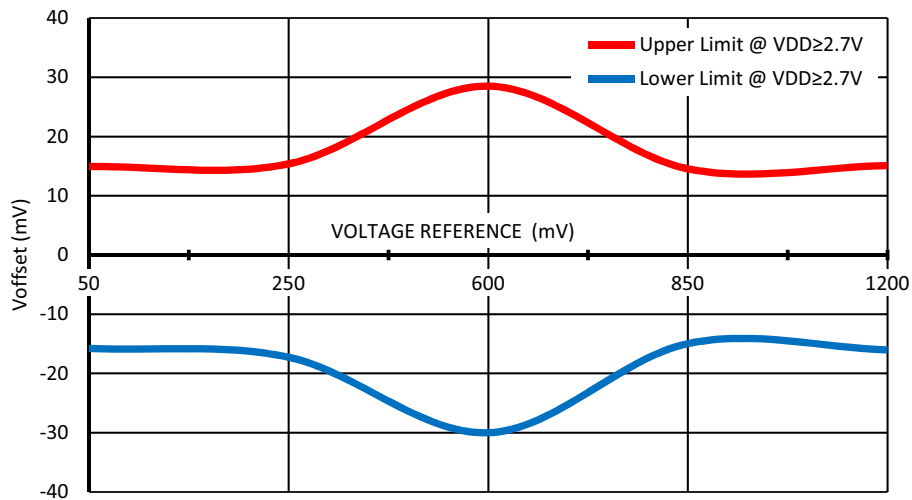

Figure 53. Typical Buffer Input Voltage Offset vs. Voltage Reference at T = (-40.... +85)°C, Buffer Bandwidth = 1 kHz, V_{hys} = 0 mV, Gain = 1.

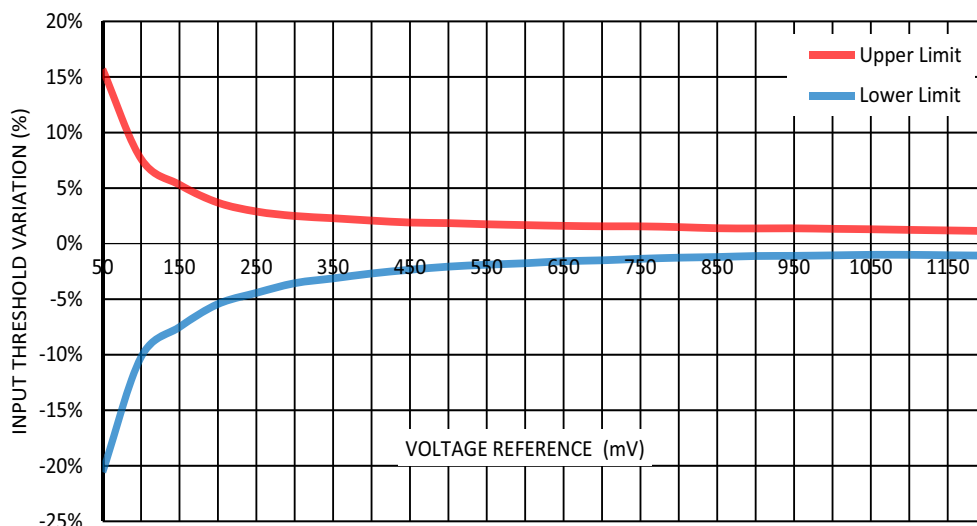

Figure 54. Typical Input Threshold Variation (including Vref variation, ACMP offset) vs. Voltage Reference at T = (-40.... +85)°C, LMB Mode - Disable, V_{hys} = 0 mV.

Note: when V_{DD} < 1.8V voltage reference should not exceed 1100 mV.

Table 76. Built-in Hysteresis Tolerance at T = 25°C

| V _{hys} (mV) | V _{DD} = (1.7-1.8) V | | | | | | V _{DD} = (1.89-5.5) V | | | | | |
|-----------------------|-------------------------------|-------|----------------------|-------|-----------------------|-------|--------------------------------|-------|----------------------|-------|-----------------------|-------|
| | Vref = (50-500) mV | | Vref = (550-1000) mV | | Vref = (1050-1200) mV | | Vref = (50-500) mV | | Vref = (550-1000) mV | | Vref = (1050-1200) mV | |
| | min | max | min | max | min | max | min | max | min | max | min | max |
| 25 | 8.6 | 32.2 | 8.6 | 32.3 | 7.0 | 32.5 | 8.5 | 32.3 | 8.5 | 32.3 | 7.8 | 34.0 |
| 50 | 44.8 | 56.5 | 43.9 | 56.7 | 42.7 | 56.4 | 44.2 | 56.8 | 43.6 | 57.3 | 43.1 | 56.0 |
| 200 | 192.8 | 207.9 | 194.0 | 208.0 | 192.7 | 205.4 | 192.0 | 208.6 | 193.0 | 209.5 | 190.8 | 207.7 |

10.1 ACMP0 Block Diagram

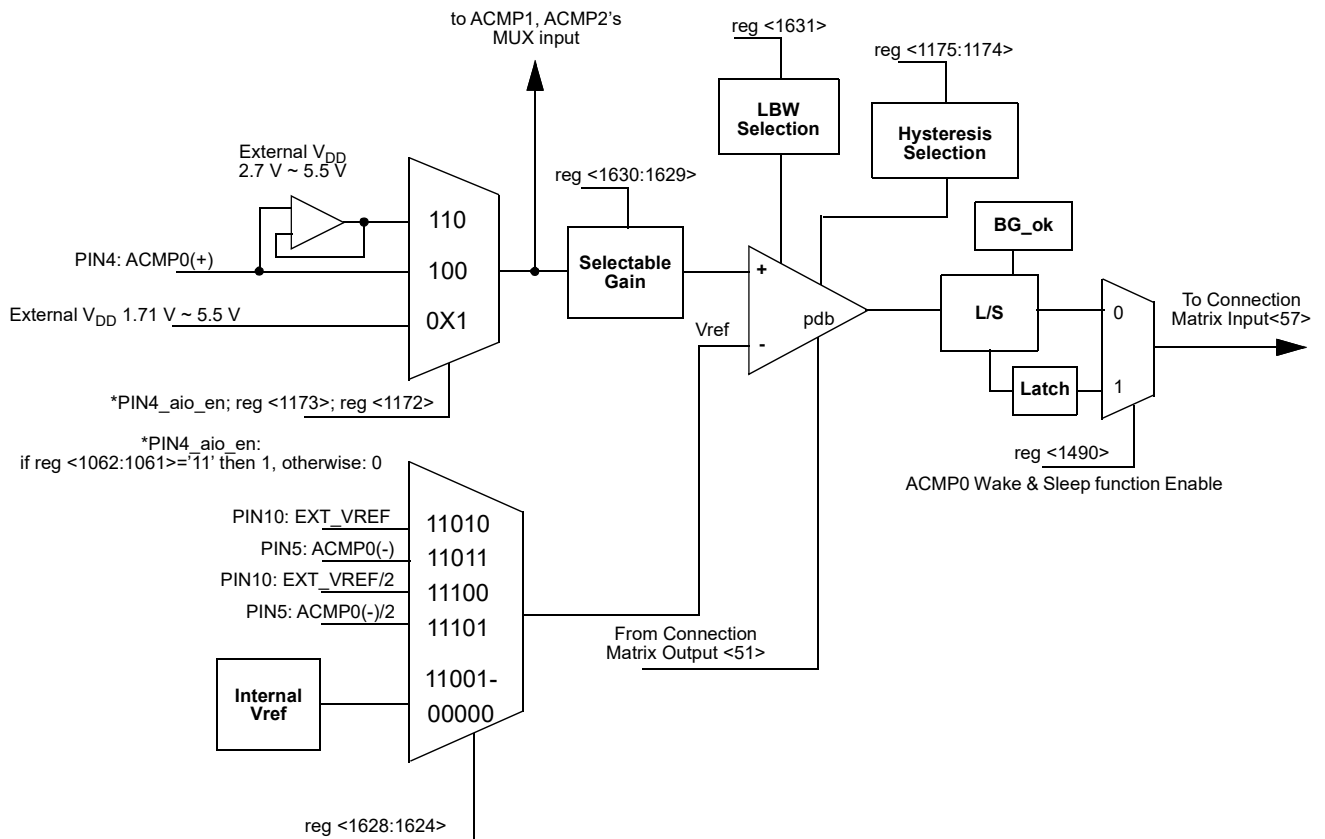
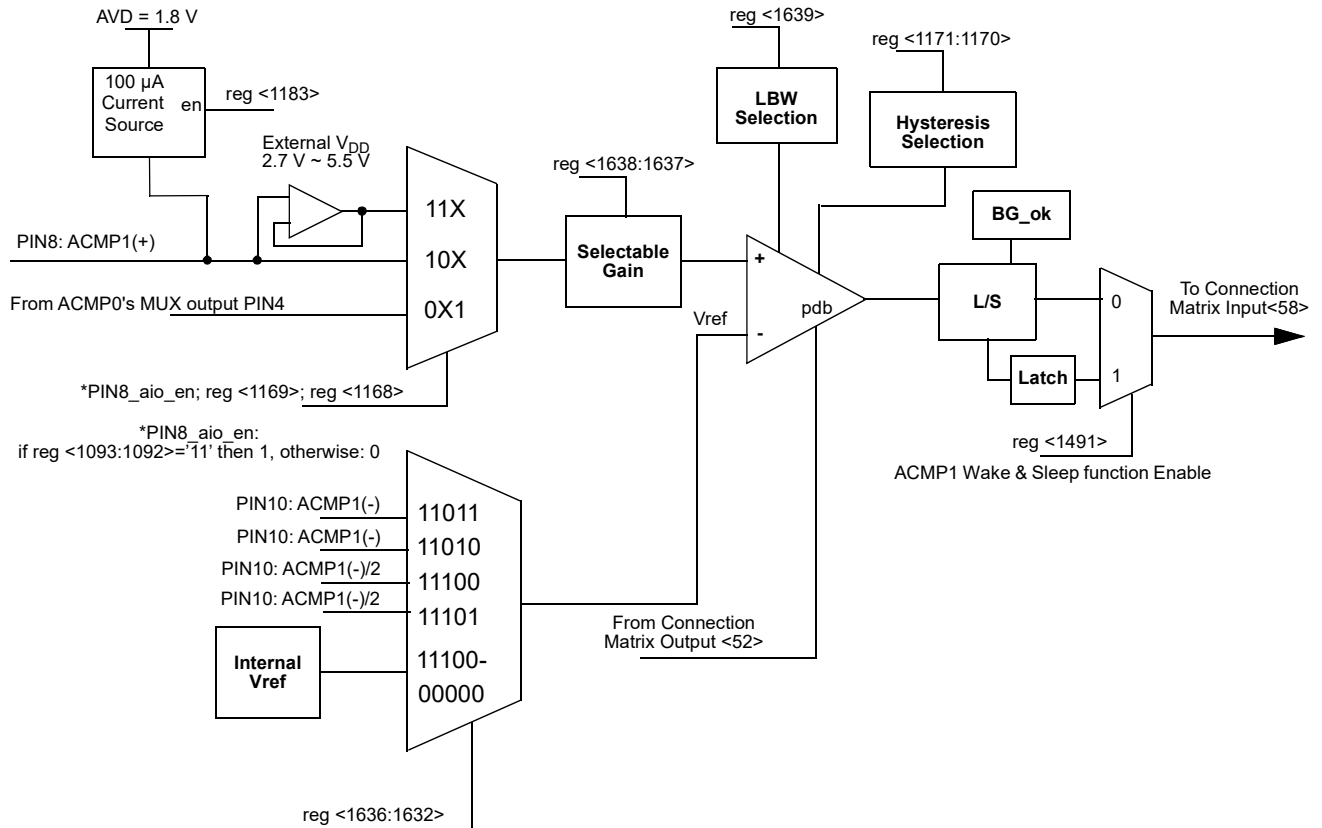

Figure 55. ACMP0 Block Diagram

10.2 ACMP0 Register Settings
Table 77. ACMP0 Register Settings

| Signal Function | Register Bit Address | Register Definition |
|---|----------------------|--|
| ACMP0 Positive Input Source Select | reg<1172> | 0: IO4 1: V _{DD} |
| ACMP0 Analog Buffer Enable | reg<1173> | 0: Disable analog buffer 1: Enable analog buffer |
| ACMP0 Hysteresis Enable | reg<1175:1174> | 00: Disabled (0 mV) 01: Enabled (25 mV) 10: Enabled (50 mV) 11: Enabled (200 mV) (01: for both external & internal VREF; 10 & 11: for only internal VREF; External VREF will not have 50 mV & 200 mV hysteresis.) |
| ACMP0 Wake & Sleep function Enable | reg<1490> | 0: Disable 1: Enable |
| ACMP0 Negative Input Voltage Select | reg<1628:1624> | 00000: 50 mV 00001: 100 mV 00010: 150 mV 00011: 200 mV 00100: 250 mV 00101: 300 mV 00110: 350 mV 00111: 400 mV 01000: 450 mV 01001: 500 mV 01010: 550 mV 01011: 600 mV 01100: 650 mV 01101: 700 mV 01110: 750 mV 01111: 800 mV 10000: 850 mV 10001: 900 mV 10010: 950 mV 10011: 1 V 10100: 1.05 V 10101: 1.1 V 10110: 1.15 V 10111: 1.2 V 11000: V _{DD} /3 11001: V _{DD} /4 11010: PIN10: EXT_VREF 11011: PIN5: ACMP0- 11100: PIN10: EXT_VREF/2 11101: PIN5: ACMP0-/2 |
| ACMP0 Positive Input Divider | reg<1630:1629> | 00: 1.00X 01: 0.50X 10: 0.33X 11: 0.25X |
| ACMP0 Low Bandwidth (Max: 1 MHz) Enable | reg<1631> | 0: Off 1: On |

10.3 ACMP1 Block Diagram



Note: when 100 μ A Current Source is enabled input voltage on Pin 8 should not exceed 1.8 V

Figure 56. ACMP1 Block Diagram

10.4 ACMP1 Register Settings
Table 78. ACMP1 Register Settings

| Signal Function | Register Bit Address | Register Definition |
|--|----------------------|---|
| ACMP1 100 μ A Current Source Enable | reg<1183> | 0: Disable 1: Enable |
| ACMP1 Positive Input Source Select | reg<1168> | 0: IO8 1: ACMP0 IN+ source |
| ACMP1 Analog Buffer Enable (max. band width 1 MHz) | reg<1169> | 0: Disable analog buffer 1: Enable analog buffer |
| ACMP1 Hysteresis Enable | reg<1171:1170> | 00: Disabled (0 mV) 01: Enabled (25 mV) 10: Enabled (50 mV) 11: Enabled (200 mV) (01: for both external & internal VREF; 10 & 11: for only internal VREF; External VREF will not have 50 mV & 200 mV hysteresis) |
| ACMP1 Wake & Sleep function Enable | reg<1491> | 0: Disable 1: Enable |
| ACMP1 Negative Input Voltage Select | reg<1636:1632> | 00000: 50 mV 00001: 100 mV 00010: 150 mV 00011: 200 mV 00100: 250 mV 00101: 300 mV 00110: 350 mV 00111: 400 mV 01000: 450 mV 01001: 500 mV 01010: 550 mV 01011: 600 mV 01100: 650 mV 01101: 700 mV 01110: 750 mV 01111: 800 mV 10000: 850 mV 10001: 900 mV 10010: 950 mV 10011: 1 V 10100: 1.05 V 10101: 1.1 V 10110: 1.15 V 10111: 1.2 V 11000: $V_{DD}/3$ 11001: $V_{DD}/4$ 11010: PIN10: EXT_VREF 11011: Reserved 11100: PIN10: EXT_VREF/2 11101: Reserved |
| ACMP1 Positive Input Divider | reg<1638:1637> | 00: 1.00X 01: 0.50X 10: 0.33X 11: 0.25X |
| ACMP1 Low Bandwidth (Max: 1 MHz) Enable | reg<1639> | 0: Off 1: On |

10.5 ACMP2 Block Diagram

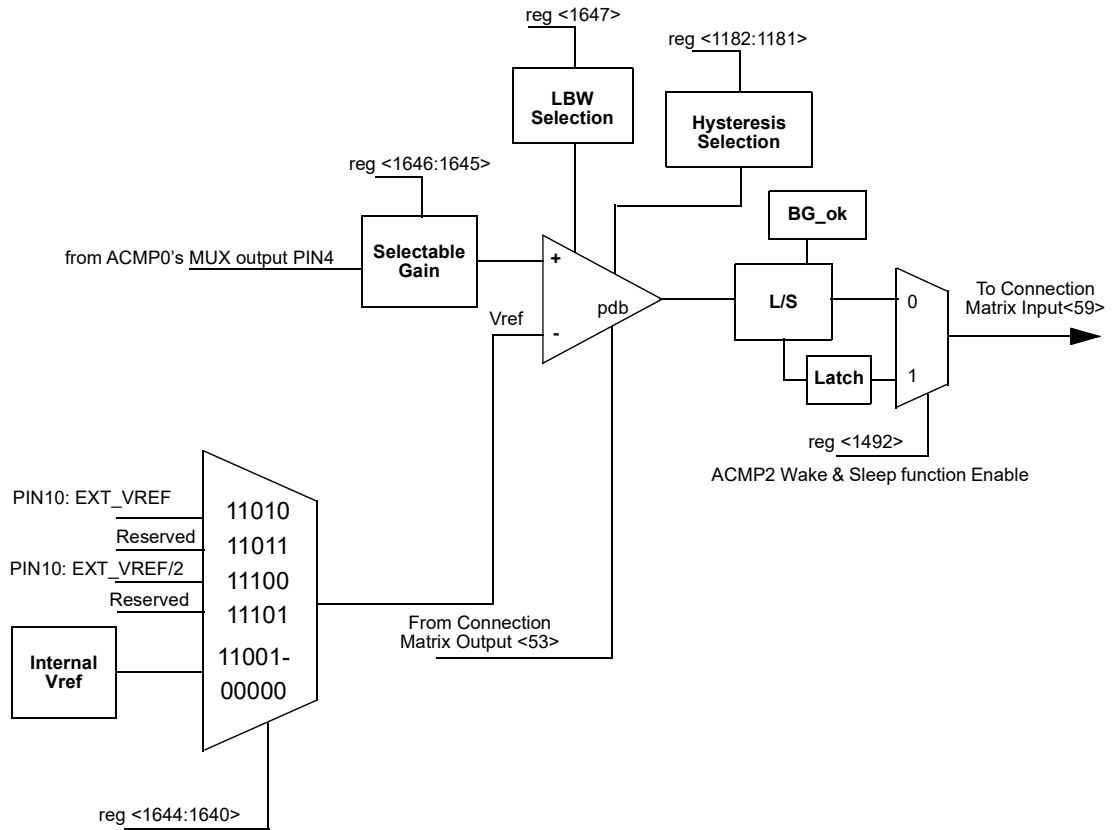

Figure 57. ACMP2 Block Diagram

10.6 ACMP2 Register Settings
Table 79. ACMP2 Register Settings

| Signal Function | Register Bit Address | Register Definition |
|---|----------------------|---|
| ACMP2 Hysteresis Enable | reg<1182:1181> | 00: Disabled (0 mV) 01: Enabled (25 mV) 10: Enabled (50 mV) 11: Enabled (200 mV) (01: for both external & internal VREF; 10 & 11: for only internal VREF; External VREF will not have 50 mV & 200 mV hysteresis) |
| ACMP2 Wake & Sleep function Enable | reg<1492> | 0: Disable 1: Enable |
| ACMP2 Negative Input Voltage Select | reg<1644:1640> | 00000: 50 mV 00001: 100 mV 00010: 150 mV 00011: 200 mV 00100: 250 mV 00101: 300 mV 00110: 350 mV 00111: 400 mV 01000: 450 mV 01001: 500 mV 01010: 550 mV 01011: 600 mV 01100: 650 mV 01101: 700 mV 01110: 750 mV 01111: 800 mV 10000: 850 mV 10001: 900 mV 10010: 950 mV 10011: 1 V 10100: 1.05 V 10101: 1.1 V 10110: 1.15 V 10111: 1.2 V 11000: $V_{DD}/3$ 11001: $V_{DD}/4$ 11010: PIN10: EXT_VREF 11011: Reserved 11100: PIN10: EXT_VREF/2 11101: Reserved |
| ACMP2 Positive Input Divider | reg<1646:1645> | 00: 1.00X 01: 0.50X 10: 0.33X 11: 0.25X |
| ACMP2 Low Bandwidth (Max: 1 MHz) Enable | reg<1647> | 0: Off 1: On |

11.0 Pipe Delay (PD)

The SLG46534 has a pipe delay logic cell that is shared with the 3-bit LUT10 in one of the Combination Function macrocells. The user can select one of these functions to use in a design, but not both. Please see Section 9.5 *3-Bit LUT or Pipe Delay Macrocell* for the description of this Combination Function macrocell.

12.0 Programmable Delay / Edge Detector

The SLG46534 has a programmable time delay logic cell available that can generate a delay that is selectable from one of four timings configured in the GreenPAK Designer. The programmable time delay cell can generate one of four different delay patterns, rising edge detection, falling edge detection, both edge detection and both edge delay. See the timing diagrams below for further information.

Note: The input signal must be longer than the delay, otherwise it will be filtered out.

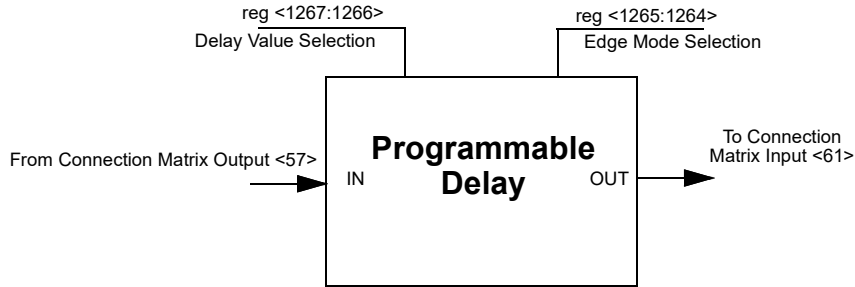

Figure 58. Programmable Delay

12.1 Programmable Delay Timing Diagram - Edge Detector Output

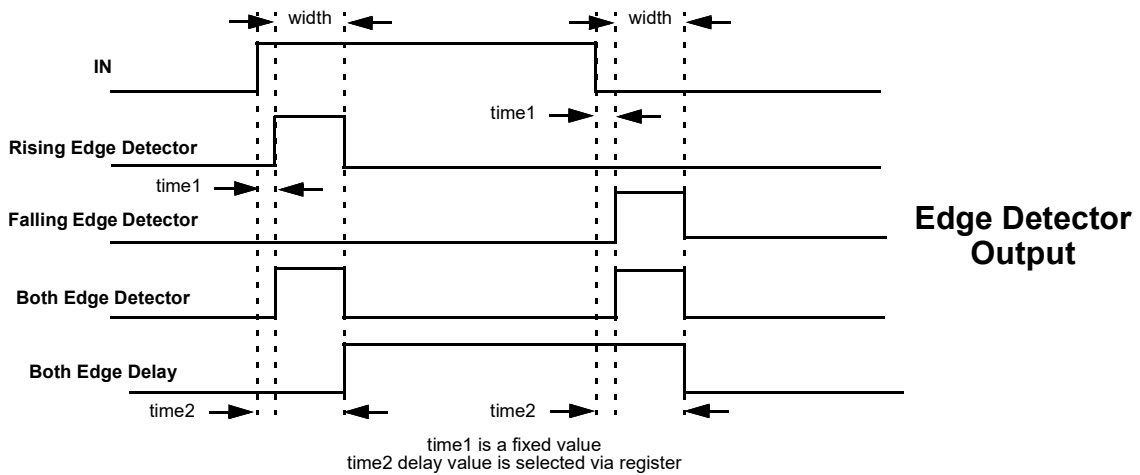

Figure 59. Edge Detector Output

Please refer to Table 5. *Expected Delays and Widths (typical)*

12.2 Programmable Delay Register Settings
Table 80. Programmable Delay Register Settings

| Signal Function | Register Bit Address | Register Definition |
|---|----------------------|--|
| Select the edge mode of programmable delay & edge detector | reg<1265:1264> | 00: Rising Edge Detector 01: Falling Edge Detector 10: Both Edge Detector 11: Both Edge Delay |
| Delay value select for programmable delay & edge detector (V _{DD} = 3.3V, typical condition) | reg<1267:1266> | 00: 165 ns 01: 300 ns 10: 440 ns 11: 575 ns |

13.0 Additional Logic Functions

The SLG46534 has two additional logic functions that are connected directly to the Connection Matrix inputs and outputs. There are two deglitch filters, each with edge detector functions. See section 5.11 *Typical Pulse Width Performance*.

13.1 Deglitch Filter / Edge Detector

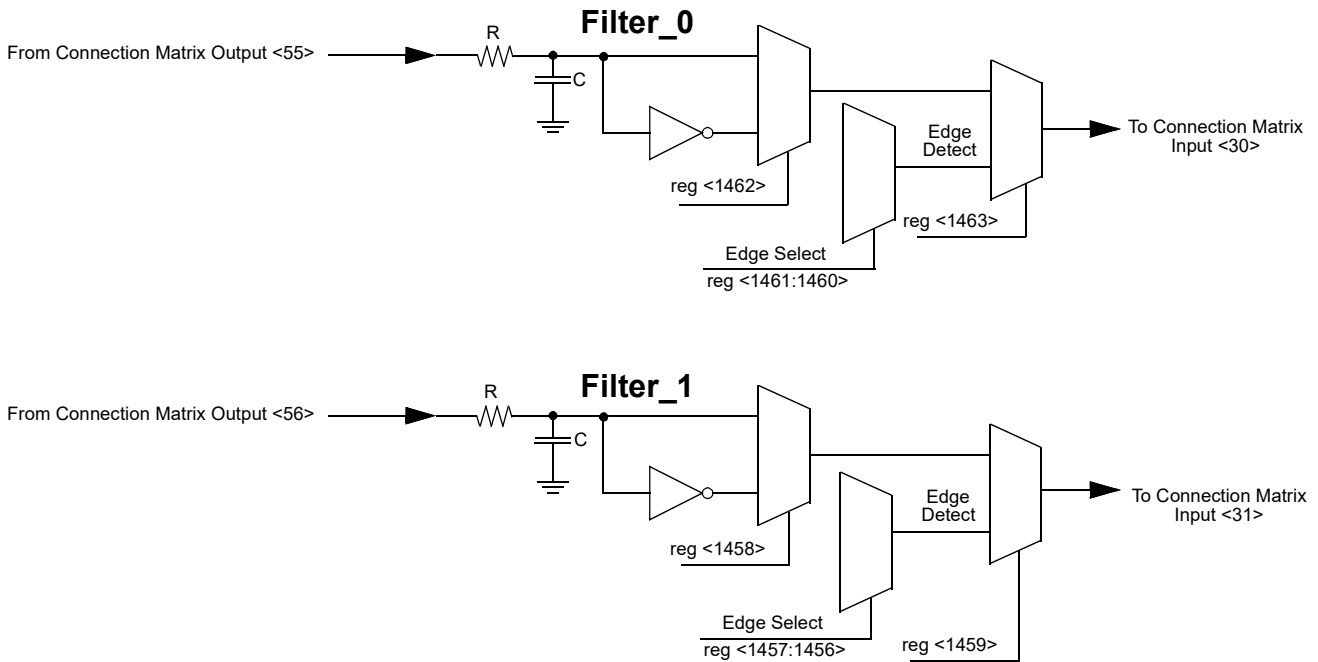

Figure 60. Deglitch Filter / Edge Detector

13.2 Deglitch Filter Register Settings

Table 81. Programmable Delay Register Settings

| Signal Function | Register Bit Address | Register Definition |
|---|----------------------|---|
| Filter_1/Edge Detector_1 Edge Select | reg<1457:1456> | 00: Rising Edge Detector 01: Fall Edge Detector 10: Both Edge Detector 11: Both Edge Delay |
| Filter_1/Edge Detector_1 output Polarity Select | reg<1458> | 0: Filter_1 output 1: Filter_1 output inverted |
| Filter_1 or Edge Detector_1 Select (Typ. 30 nS @V _{DD} = 3.3V) | reg<1459> | 0: Filter_1 1: Edge Detector_1 |
| Filter_0/Edge Detector_0 Edge Select | reg<1461:1460> | 00: Rising Edge Detector 01: Fall Edge Detector 10: Both Edge Detector 11: Both Edge Delay |

Table 81. Programmable Delay Register Settings

| Signal Function | Register Bit Address | Register Definition |
|---|----------------------|---|
| Filter_0/Edge Detector_0 output Polarity Select | reg<1462> | 0: Filter_0 output 1: Filter_0 output inverted |
| Filter_0 or Edge Detector_0 Select (Typ. 47 nS @V _{DD} = 3.3V) | reg<1463> | 0: Filter_0 1: Edge Detector_0 |

14.0 Voltage Reference (VREF)

14.1 Voltage Reference Overview

The SLG46534 has a Voltage Reference Macrocell to provide references to the four analog comparators. This macrocell can supply a user selection of fixed voltage references, $/3$ and $/4$ reference off of the V_{DD} power supply to the device, and externally supplied voltage references from PINs 5 and 11. See table below for the available selections for each analog comparator. Also see *Figure 61*. below, which shows the reference output structure.

14.2 VREF Selection Table

Table 82. VREF Selection Table

| SEL<4:0> | ACMP0_VREF | ACMP1_VREF | ACMP2_VREF |
|----------|--------------------|--------------------|--------------------|
| 11101 | PIN 5: ACMP0(-)/2 | PIN 10: ACMP1(-)/2 | PIN 11: ACMP2(-)/2 |
| 11100 | PIN 10: ACMP0(-)/2 | PIN 10: ACMP1(-)/2 | PIN 10: ACMP2(-)/2 |
| 11011 | PIN 5: ACMP0(-) | PIN 10: ACMP1(-) | PIN 11: ACMP2(-) |
| 11010 | PIN 10: ACMP0(-) | PIN 10: ACMP1(-) | PIN 10: ACMP2(-) |
| 11001 | $V_{DD} / 4$ | $V_{DD} / 4$ | $V_{DD} / 4$ |
| 11000 | $V_{DD} / 3$ | $V_{DD} / 3$ | $V_{DD} / 3$ |
| 10111 | 1.20 | 1.20 | 1.20 |
| 10110 | 1.15 | 1.15 | 1.15 |
| 10101 | 1.10 | 1.10 | 1.10 |
| 10100 | 1.05 | 1.05 | 1.05 |
| 10011 | 1.00 | 1.00 | 1.00 |
| 10010 | 0.95 | 0.95 | 0.95 |
| 10001 | 0.90 | 0.90 | 0.90 |
| 10000 | 0.85 | 0.85 | 0.85 |
| 01111 | 0.80 | 0.80 | 0.80 |
| 01110 | 0.75 | 0.75 | 0.75 |
| 01101 | 0.70 | 0.70 | 0.70 |
| 01100 | 0.65 | 0.65 | 0.65 |
| 01011 | 0.60 | 0.60 | 0.60 |
| 01010 | 0.55 | 0.55 | 0.55 |
| 01001 | 0.50 | 0.50 | 0.50 |
| 01000 | 0.45 | 0.45 | 0.45 |
| 00111 | 0.40 | 0.40 | 0.40 |
| 00110 | 0.35 | 0.35 | 0.35 |
| 00101 | 0.30 | 0.30 | 0.30 |
| 00100 | 0.25 | 0.25 | 0.25 |
| 00011 | 0.20 | 0.20 | 0.20 |
| 00010 | 0.15 | 0.15 | 0.15 |
| 00001 | 0.10 | 0.10 | 0.10 |
| 00000 | 0.05 | 0.05 | 0.05 |

| V_{DD} | Practical VREF Range | Note |
|---------------|----------------------|----------------------------|
| 2.0 V - 5.5 V | 50 mV ~ 1.2 V | |
| 1.7 V - 2.0 V | 50 mV ~ 1.0 V | Do not operate above 1.0 V |

14.3 VREF Block Diagram

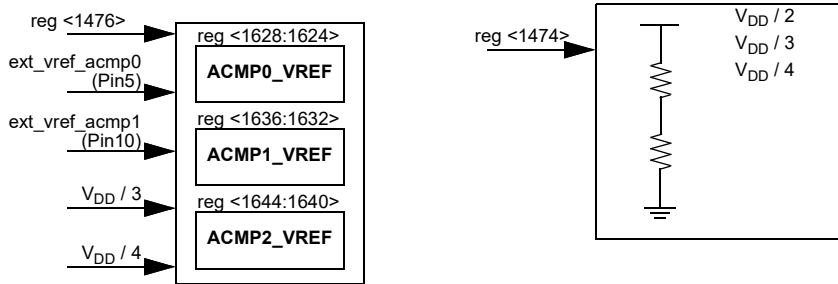

Figure 61. Voltage Reference Block Diagram

15.0 RC Oscillator (RC Osc)

The SLG46534 has three internal oscillators. RC Oscillator that runs at 25 kHz / 2 MHz (OSC0), Oscillator that runs at 25 MHz (OSC1) and Crystal Oscillator. It is possible to use all three oscillators simultaneously. The fundamental frequency can also come from clock input (Pin 14 for 25 kHz / 2 MHz and Pin 13 for 25 MHz or Crystal OSC), see section 20.0 External Clocking.

15.1 25 kHz/2 MHz and 25 MHz RC Oscillators

There are two divider stages that allow the user flexibility for introducing clock signals on various Connection Matrix Input lines. The predivider allows the selection of /1, /2, /4 or /8 divide down frequency from the fundamental. The second stage divider (only for 25 kHz / 2 MHz Oscillator) has an input of frequency from the predivider, and outputs one of seven different frequencies on Connection Matrix Input lines <27> (OUT0) and <28> (OUT1). See *Figure 62.* and *Figure 63.* below for details.

There are two modes of the POWER CONTROL pin, (reg<1658> for 25 kHz / 2 MHz OSC and reg<1657> for 25 MHz OSC):

- **POWER DOWN <0>**. If PWR CONTROL input of oscillator is LOW, the oscillator will be turned on. If PWR CONTROL input of oscillator is HIGH the oscillator will be turned off and OSC divider will reset.
- **FORCE ON <1>**. If PWR CONTROL input of oscillator is HIGH, the oscillator will be turned on. If PWR CONTROL input of oscillator is LOW the oscillator will be turned off.

The PWR CONTROL signal has the highest priority.

The SLG46534 has a 25 kHz / 2 MHz OSC FAST START-UP function reg<1338> (1 – on, 0 – off). It allows the OSC to run immediately after power-up. Start-up time is less than one cycle. Note that when OSC FAST START-UP is on, the current consumption will rise.

The user can select two OSC POWER MODEs (reg<1343 for 25 kHz / 2 MHz OSC and reg<1341> for 25 MHz OSC):

- If **AUTO POWER ON <0>** is selected, the OSC will run only when any macrocell that uses OSC is powered on.
- If **FORCE POWER ON <1>** is selected, the OSC will run when the SLG46534 is powered on.

OSC can be turned on by:

- Register control (force power on)
- Delay mode, when delay requires OSC
- CNT/FSM

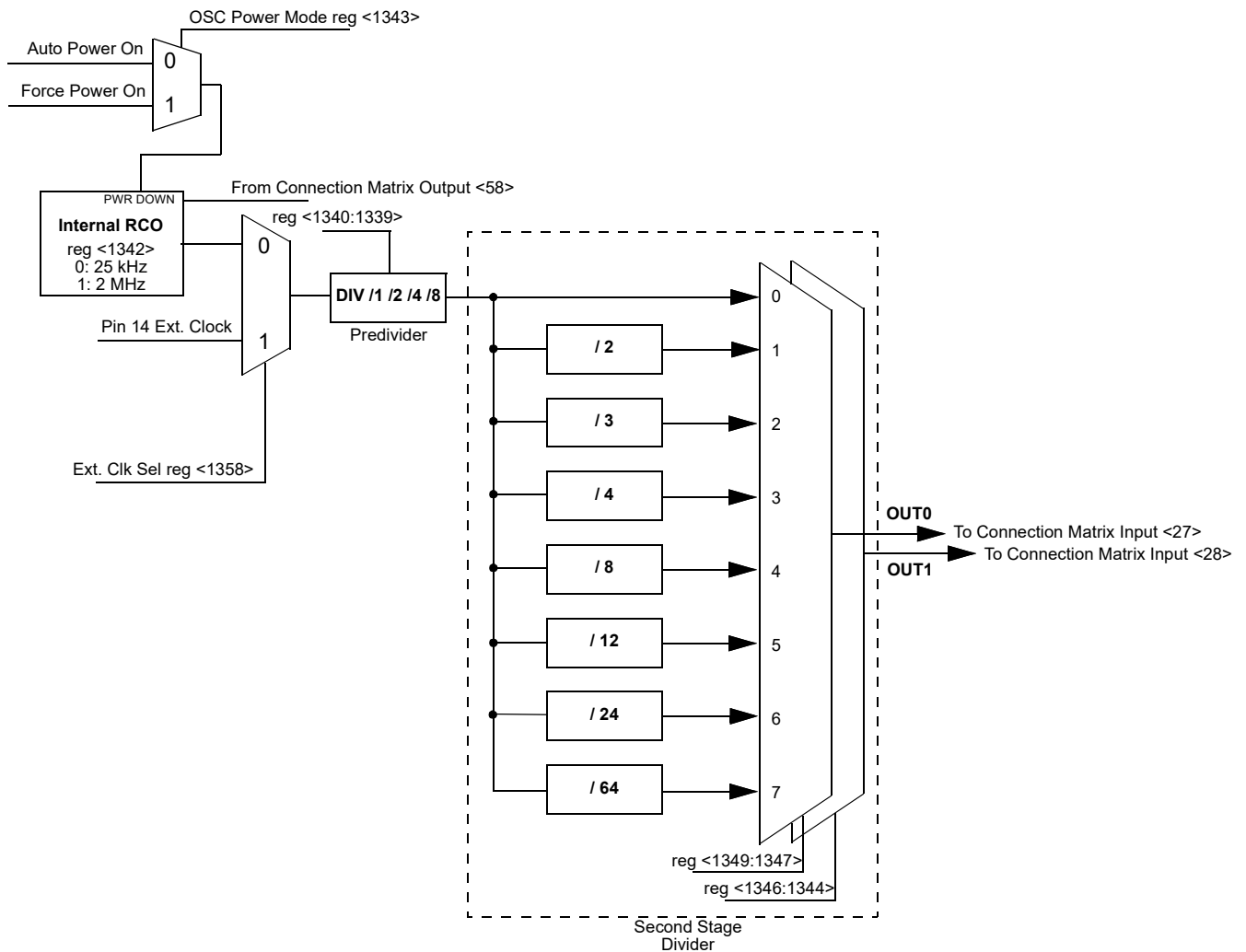

Figure 62. 25 kHz / 2 MHz RC OSC Block Diagram

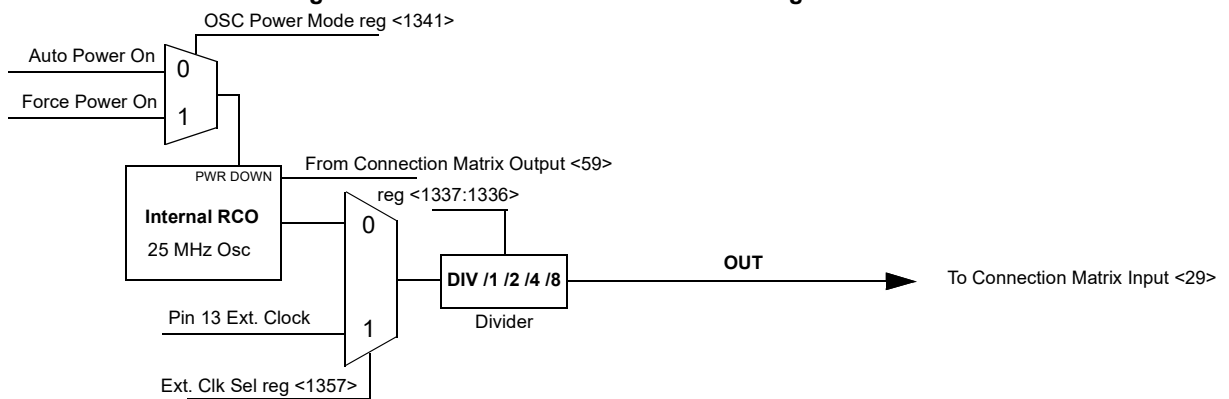

Figure 63. 25 MHz RC OSC Block Diagram

15.2 Oscillator Power On delay

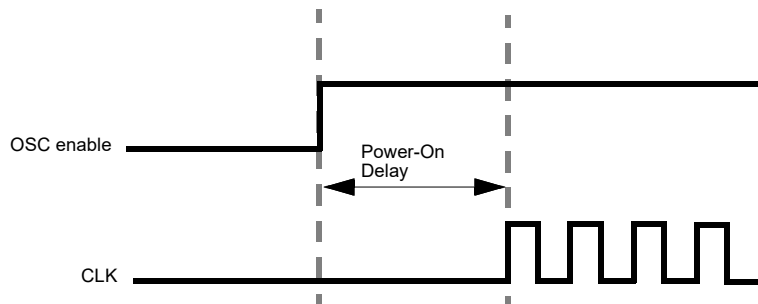

Figure 64. Oscillator Startup Diagram

Note 1: OSC power mode: "Auto Power On".

Note 2: 'OSC enable' signal appears when any macrocell that uses OSC is powered on.

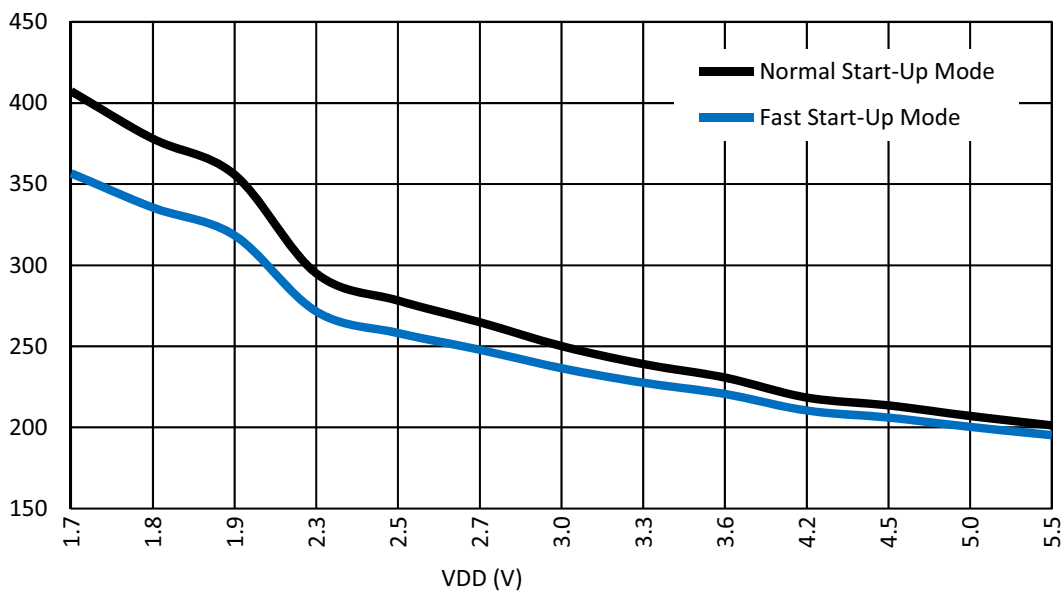

Figure 65. RC Oscillator Maximum Power On Delay vs. V_{DD} at room temperature, OSC0 = 2 MHz

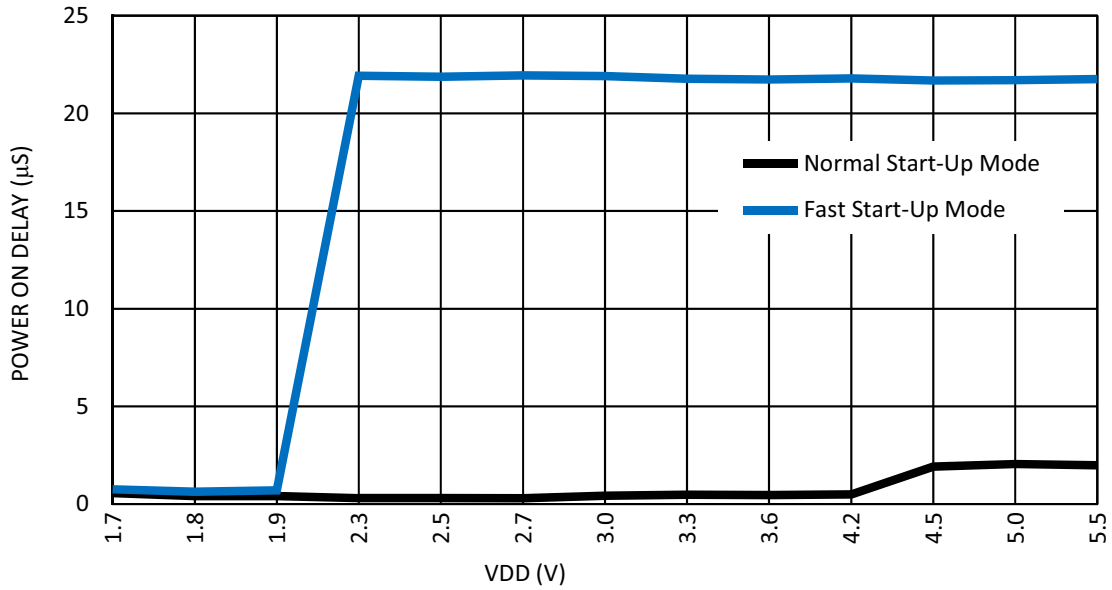

Figure 66. RC Oscillator Maximum Power On Delay vs. V_{DD} at 85°C, OSC0 = 25 kHz

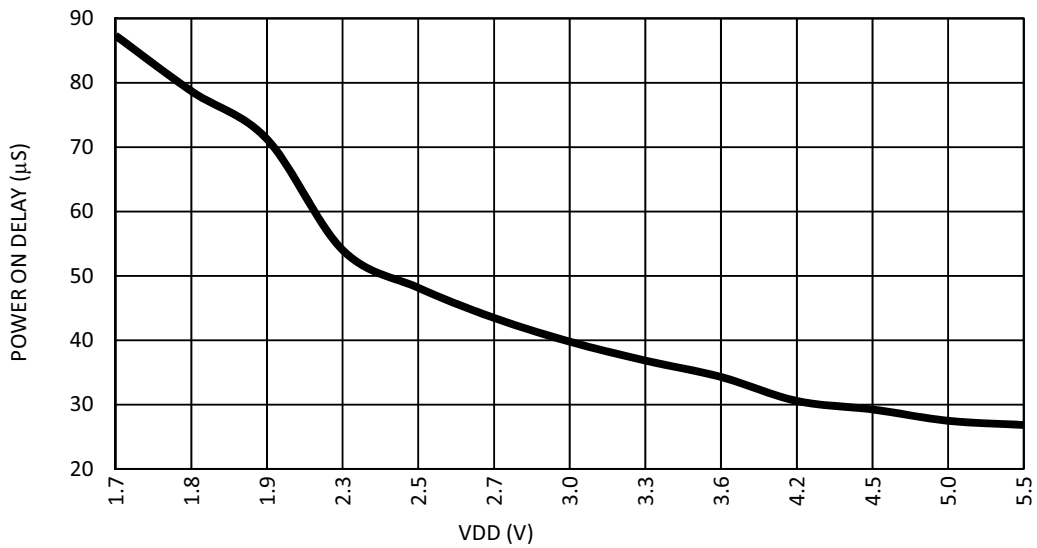

Figure 67. OSC1 (25 MHz) Maximum Power On Delay vs. V_{DD} at 85°C

15.3 Oscillator Accuracy

Note 1: OSC power setting: Force Power On; Clock to matrix input - enable; Bandgap: turn on by register - enable.

Note 2: For more information see section 5.12 OSC Specifications.

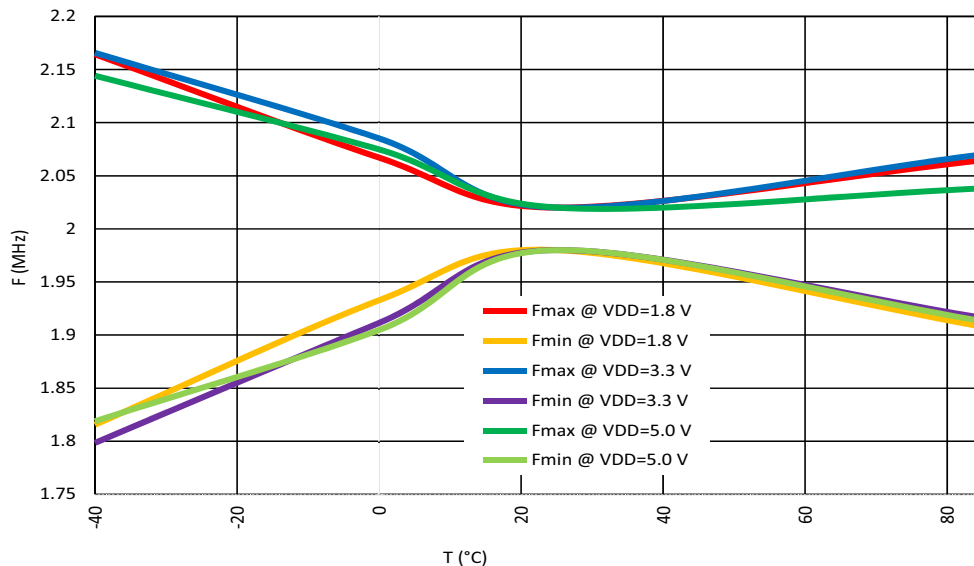

Figure 68. RC Oscillator Frequency vs. Temperature, RC OSC0 = 2 MHz

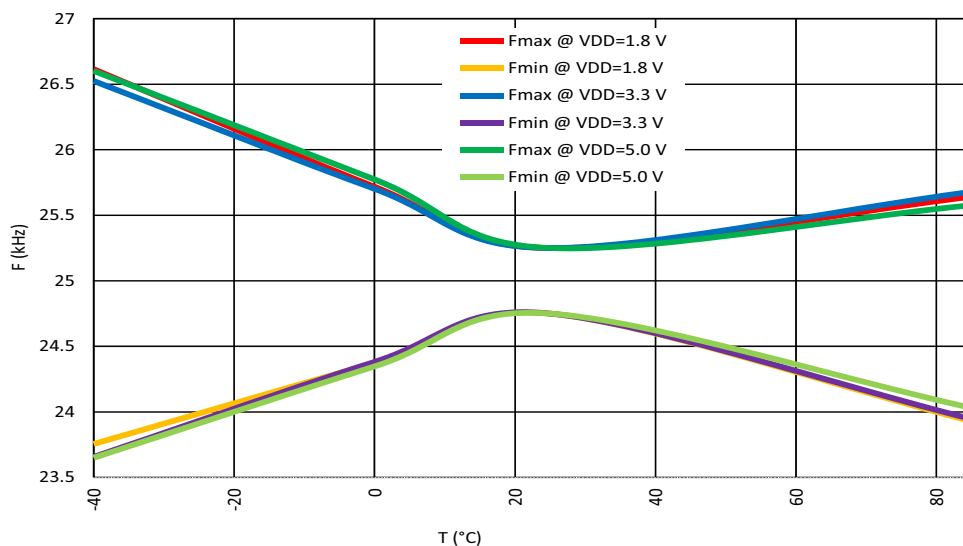

Figure 69. RC Oscillator Frequency vs. Temperature, RC OSC0 = 25 kHz

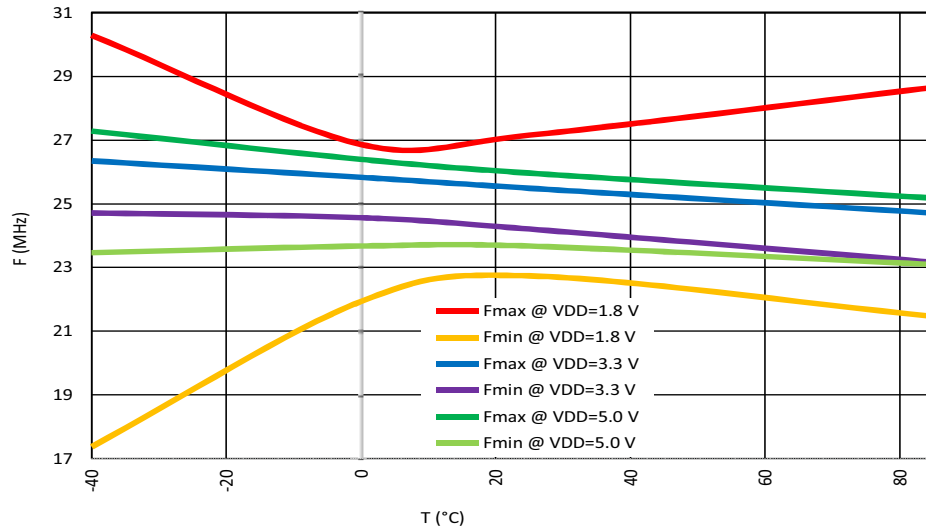

Figure 70. OSC1 (25 MHz) Frequency vs. Temperature

Note: 25 MHz RC OSC1 performance is not guaranteed at $V_{DD} < 2.5$ V.

16.0 Crystal Oscillator

The Crystal OSC provides an inverter circuit which can be connected to external components such as an external quartz crystal or ceramic resonator to create a precise and stable frequency output. As shown in *Figure 72.* , Pin 13 and Pin 12 are the inverter’s input and output respectively. To ensure start-up, 2.7 V or greater on VDD is recommended so that the inverter has enough gain-bandwidth. Start-up margin depends on crystal/resonator characteristics which vary by frequency, size, cut, and manufacturer. Optimal values of external components depend on stray capacitances, crystal/resonator characteristics and noise from the environment. For typical component values, please refer to *Table 83* as a starting point. For ceramic resonators, capacitors as recommended by the manufacturer can be used.

An alternative use of Crystal OSC is as a clock buffer, in which case an external clock source can be connected to Pin 13. For this use, VDD can be as low as 1.71 V, but note that the Crystal OSC inverter is slower at lower VDD voltages, and hence the longer rise and fall delays may result in more duty cycle skew for higher frequency clocks.

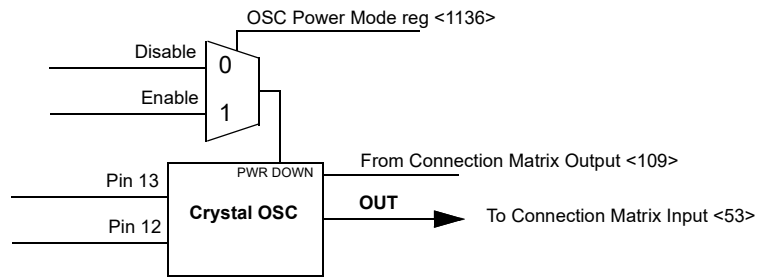

Figure 71. Crystal OSC Block Diagram

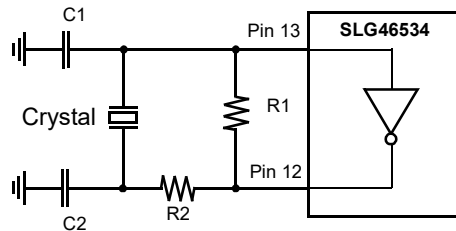

Figure 72. External Crystal Connection

Table 83. External Components Selection Table

| f | C1 | C2 | R1 | R2 |
|------------|-------|--------|-------|-------|
| 32.768 kHz | 10 pF | 330 pF | 20 MΩ | 20 kΩ |
| 4 - 40 MHz | 12 pF | 12 pF | 1 MΩ | 0 Ω |

17.0 Power On Reset (POR)

The SLG46534 has a power-on reset (POR) macrocell to ensure correct device initialization and operation of all macrocells in the device. The purpose of the POR circuit is to have consistent behavior and predictable results when the V_{DD} power is first ramping to the device, and also while the V_{DD} is falling during power-down. To accomplish this goal, the POR drives a defined sequence of internal events that trigger changes to the states of different macrocells inside the device, and finally to the state of the IO pins.

17.1 General Operation

The SLG46534 is guaranteed to be powered down and nonoperational when the V_{DD} voltage (voltage on PIN1) is less than Power Off Threshold (see in Electrical Characteristics table), but not less than -0.6 V. Another essential condition for the chip to be powered down is that no voltage higher (see Note 1) than the V_{DD} voltage is applied to any other PIN. For example, if V_{DD} voltage is 0.3 V, applying a voltage higher than 0.3 V to any other PIN is incorrect, and can lead to incorrect or unexpected device behavior.

Note 1. There is a 0.6 V margin due to forward drop voltage of the ESD protection diodes.

To start the POR sequence in the SLG46534, the voltage applied on the V_{DD} should be higher than the Power_ON threshold (see Note 2). The full operational V_{DD} range for the SLG46534 is 1.71 V – 5.5 V (1.8 V \pm 5% - 5 V \pm 10%). This means that the V_{DD} voltage must ramp up to the operational voltage value, but the POR sequence will start earlier, as soon as the V_{DD} voltage rises to the Power_ON threshold. After the POR sequence has started, the SLG46534 will have a typical period of time to go through all the steps in the sequence (noted in the datasheet for that device), and will be ready and completely operational after the POR sequence is complete.

Note 2. The Power_ON threshold is defined in Electrical Characteristics table.

To power down the chip the V_{DD} voltage should be lower than the operational and to guarantee that chip is powered down it should be less than Power Off Threshold.

All PINs are in high impedance state when the chip is powered down and while the POR sequence is taking place. The last step in the POR sequence releases the IO structures from the high impedance state, at which time the device is operational. The pin configuration at this point in time is defined by the design programmed into the chip. Also as it was mentioned before the voltage on PINs can't be bigger than the V_{DD} , this rule also applies to the case when the chip is powered on.

17.2 POR Sequence

The POR system generates a sequence of signals that enable certain macrocells. The sequence is shown in *Figure 73*.

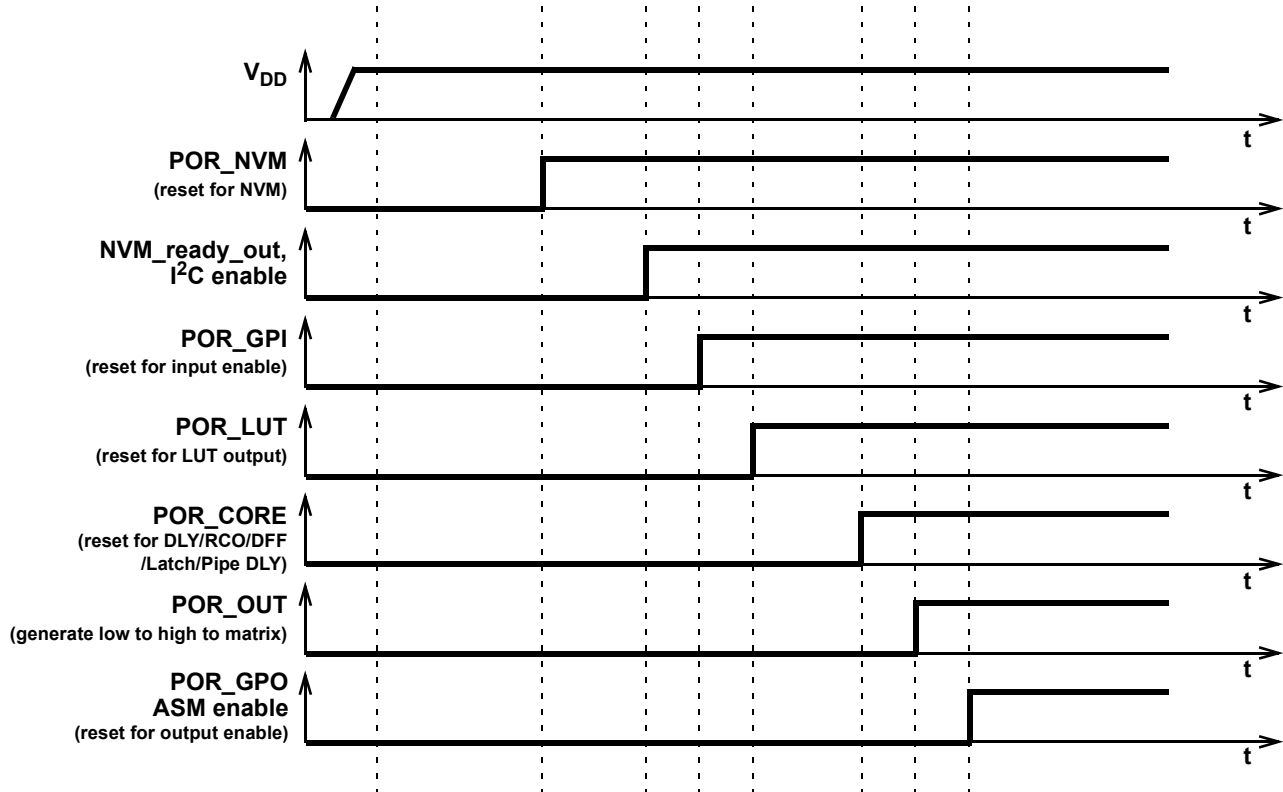

Figure 73. POR sequence

As can be seen from *Figure 73*, after the V_{DD} has start ramping up and crosses the Power_ON threshold, first, the on-chip NVM memory is reset. Next the chip reads the data from NVM, and transfers this information to SRAM registers that serve to configure each macrocell, and the Connection Matrix which routes signals between macrocells. The third stage causes the reset of the input pins, and then to enable them. After that, the LUTs are reset and become active. After LUTs the Delay cells, RC OSC, DFFs, Latches and Pipe Delay are initialized. Only after all macrocells are initialized internal POR signal (POR macrocell output) goes from LOW to HIGH. The last portion of the device to be initialized are the output PINs, which transition from high impedance to active at this point.

The typical time that takes to complete the POR sequence varies by device type in the GreenPAK family. It also depends on many environmental factors, such as: slew rate, V_{DD} value, temperature and even will vary from chip to chip (process influence).

17.3 Macrocells Output States During POR Sequence

To have a full picture of SLG46534 operation during powering and POR sequence, review the overview the macrocell output states during the POR sequence (Figure 74. describes the output signals states).

First, before the NVM has been reset, all macrocells have their output set to logic LOW (except the output PINs which are in high impedance state). Before the NVM is ready, all macrocell outputs are unpredictable (except the output PINs). On the next step, some of the macrocells start initialization: input pins output state becomes LOW; LUTs also output LOW. Only P DLY macrocell configured as edge detector becomes active at this time. After that input PINs are enabled. Next, only LUTs are configured. Next, all other macrocells are initialized. After macrocells are initialized, internal POR matrix signal switches from LOW to HIGH. The last are output PINs that become active and determined by the input signals.

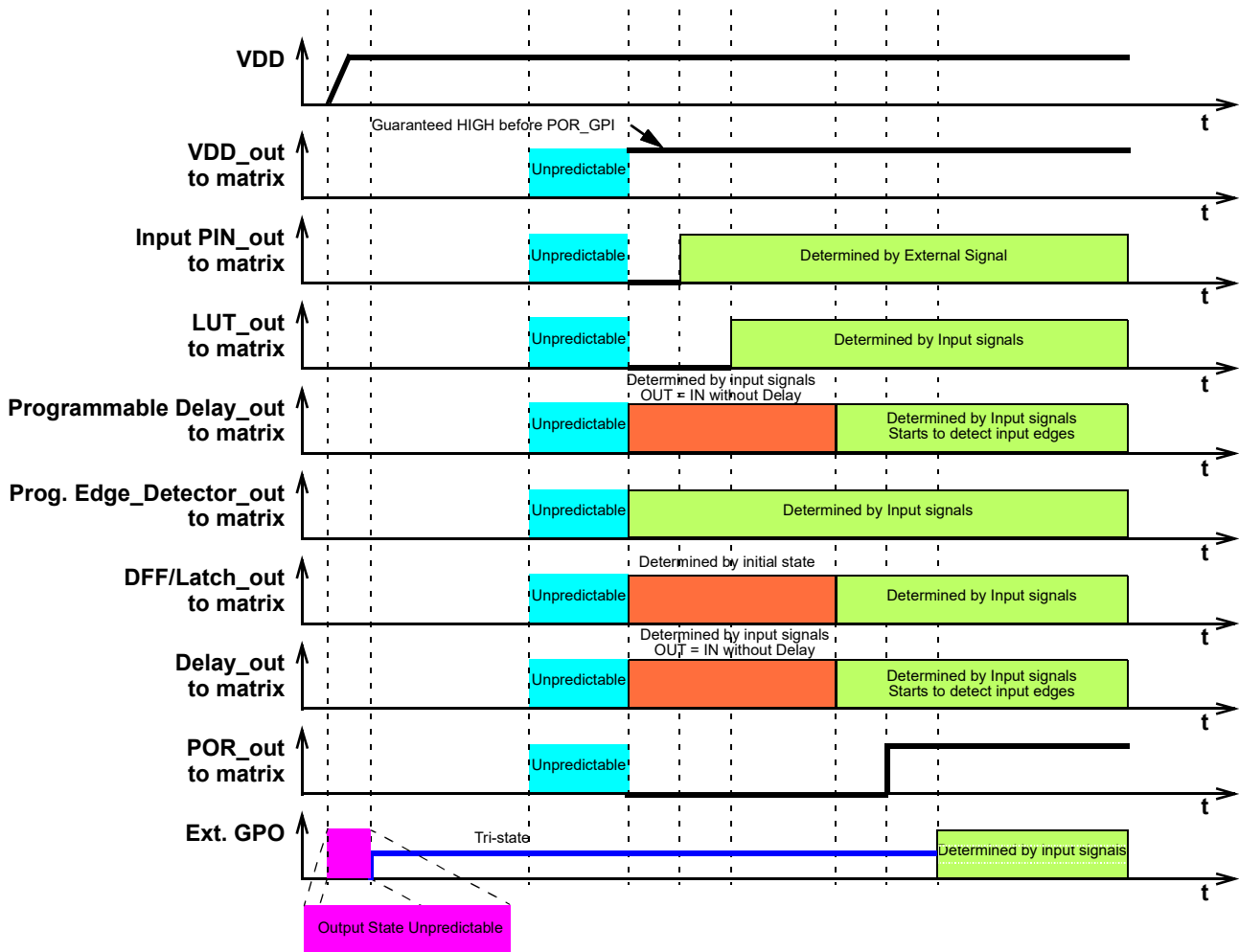

Figure 74. Internal Macrocell States during POR sequence

17.3.1 Initialization

All internal macrocells by default have initial low level. Starting from indicated power-up time of 1.15 V - 1.6 V, macrocells in GPAK are powered on while forced to the reset state, All outputs are in Hi-Z and chip starts loading data from NVM. Then the reset signal is released for internal macrocells and they start to initialize according to the following sequence:

1. I²C;
2. Input PINs, ACMP, pull up/down;
3. LUTs;
4. DFFs, Delays/Counters, Pipe Delay;
5. POR output to matrix;
6. Output PIN corresponds to the internal logic.

The POR signal going high indicates the mentioned power-up sequence is complete.

Note: The maximum voltage applied to any PIN should not be higher than the V_{DD} level. There are ESD Diodes between PIN → V_{DD} and PIN → GND on each PIN. So if the input signal applied to PIN is higher than V_{DD}, then current will sink through the diode to V_{DD}. Exceeding V_{DD} results in leakage current on the input PIN, and V_{DD} will be pulled up, following the voltage on the input PIN. There is no effect from input pin when input voltage is applied at the same time as V_{DD}.

17.3.2 Power Down

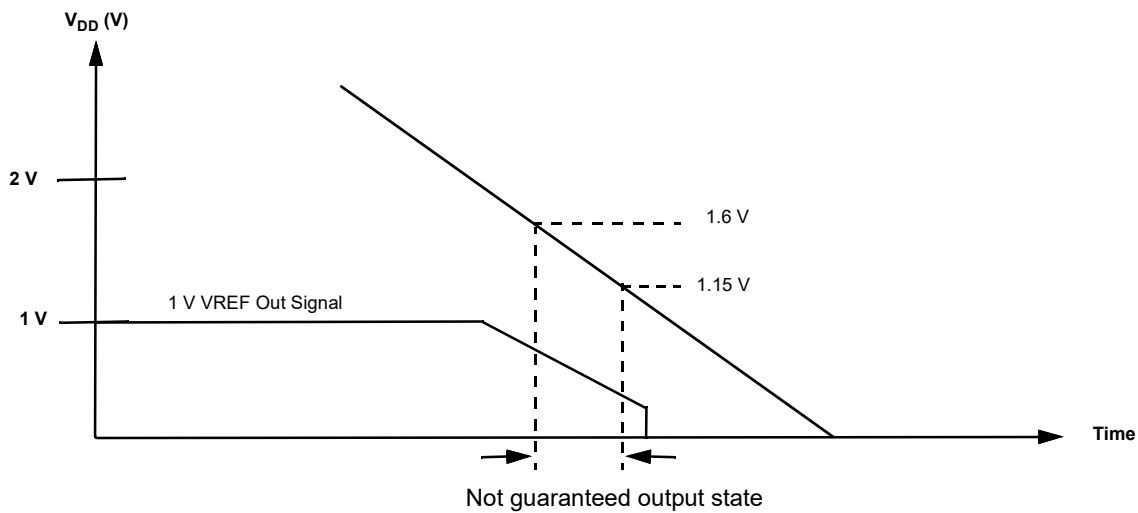

Figure 75. Power Down

During powerdown, macrocells in SLG46534 are powered off after V_{DD} falling down below Power Off Threshold. Please note that during a slow rampdown, outputs can possibly switch state during this time.

18.0 Asynchronous State Machine (ASM) Macrocell

18.1 ASM Macrocell Overview

The Asynchronous State Machine (ASM) macrocell is designed to allow the user to create state machines with between 2 to 8 states. The user has flexibility to define the available states, the available state transitions, and the input signals (a, b, c ...) that will cause transitions from one state to another state, as shown in *Figure 76*.

This macrocell has a total of 25 inputs, as shown in *Figure 77*, which come from the Connection Matrix outputs. Of these 25 inputs, 24 are user selectable for driving general state transitions, and 1 is for driving a state transition to an Initial / Reset state. Each of the 24 inputs is level sensitive and active high, meaning that a high level input will drive the user selected transition from one state to another. The fact that there are 24 inputs puts the upper bound of 24 possible state transitions total in the user defined state machine design. There is an nReset input which will drive an immediate state transition to the user-defined Initial / Reset state when active, shown in red, in the *Figure 76*. For more details refer to section *18.2 ASM Inputs*.

There are a total of 8 outputs, which go to the Connections Matrix inputs, and from there can be routed to other internal macrocells or pins. The 8 outputs are user defined for each of the possible 8 states. This information is held in the Connection Matrix Output RAM. For more details refer to section *18.3 ASM Outputs*.

In using this macrocell, the user must take into consideration the critical timing required on all input and output signals. The timing waveforms and timing specifications for this macrocell are all measured relative to the input signals (which come into the macrocell on the Connection Matrix outputs) and on the outputs from the macrocell (which are direct connections to Connection Matrix inputs). The user must consider any delays from other logic and internal chip connections, including IO delays, to ensure that signals are properly processed, and state transitions are deterministic.

The GPAK Designer development tools support user designs for the ASM macrocell at both the physical level and logic level. *Figure 76* is a representation of the user design at the logical level, and *Figure 77* shows the physical resources inside the macrocell. To best utilize this macrocell, the user must develop a logical representation of their desired state machine, as well as a physical mapping of the input and outputs required for the desired functionality.

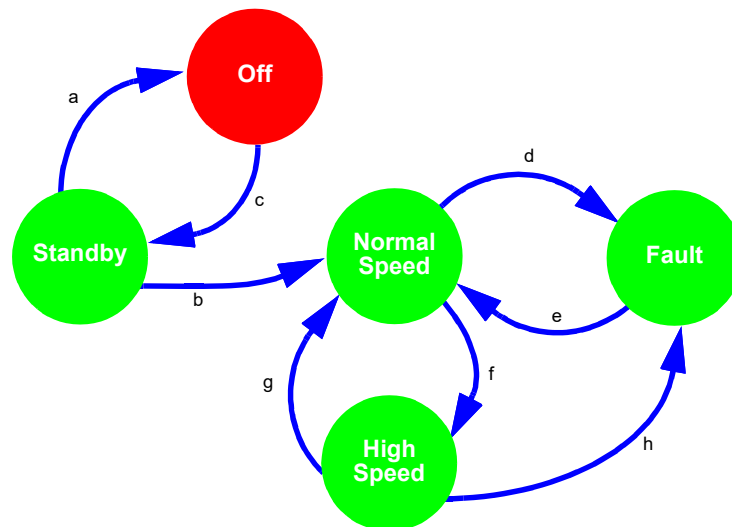

Figure 76. Asynchronous State Machine State Transitions

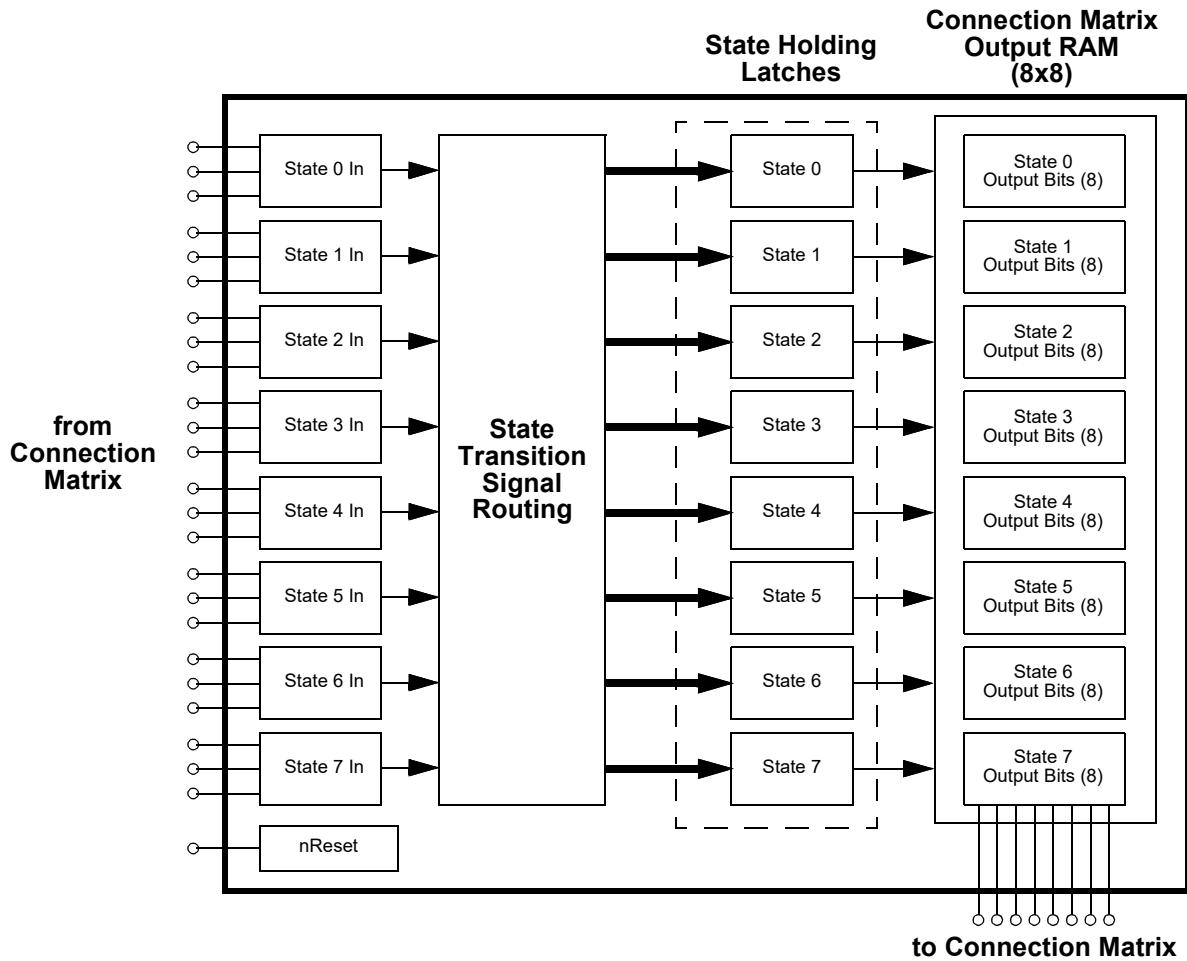

Figure 77. Asynchronous State Machine

18.2 ASM Inputs

The ASM macrocell has a total of 25 inputs which come from the Connection Matrix outputs. Of these 25 inputs, 24 are user selectable for driving general state transitions, and 1 is for driving a state transition to an Initial / Reset state.

There are a total of 24 inputs to the ASM macrocell for general state transitions, highlighted in red in *Figure 78*. Each of these inputs is level sensitive, and active high. A high level input will trigger a state transition.

These inputs are grouped so that each set of 3 inputs can drive a state transition **going into** a particular state. As an example, there are three inputs that can drive a state transition to State 1. This sets an upper bound on the number of transitions that the user can select going into a particular state to be 3, shown in *Figure 79*.

There is no limitation on the number of transitions that can be supported coming out of a particular state, the user can select to have transitions going from a state to all other states, shown in *Figure 80*.

The ASM macrocell also has a nReset input highlighted in blue in *Figure 78*. This input is level sensitive and active low. An active signal on this input will drive an immediate state transition to the user-defined Initial / Reset state. The user can choose which state within the ASM Editor inside GPAK Designer is the initial state.

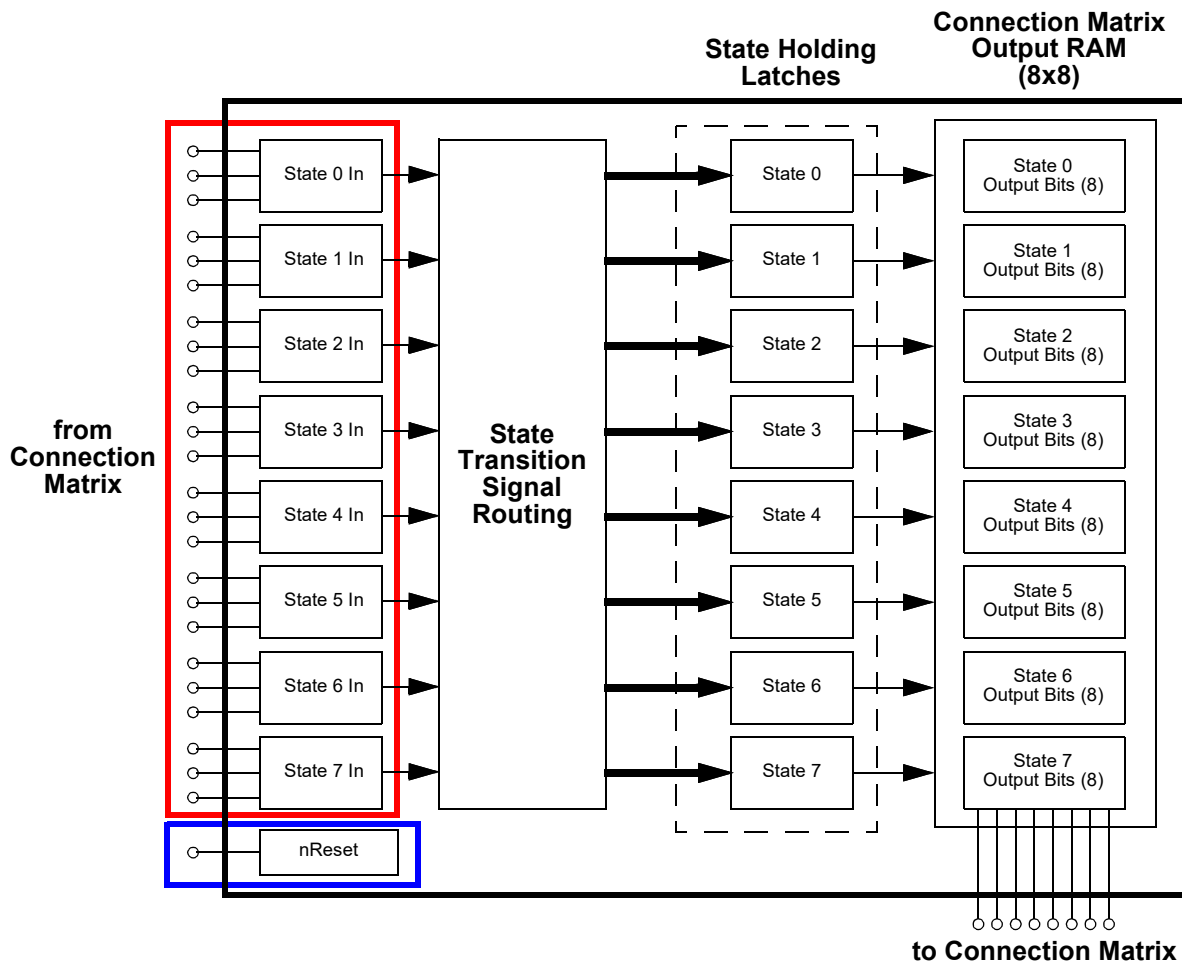

Figure 78. Asynchronous State Machine Inputs

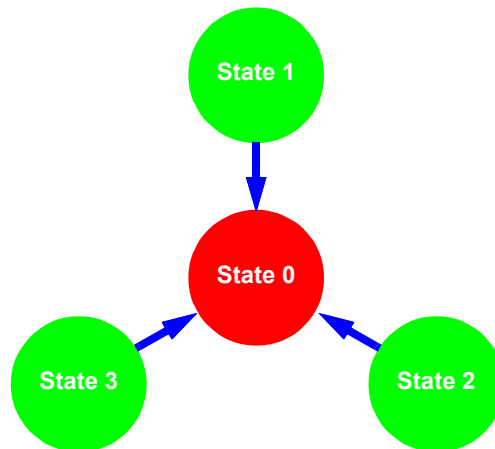

Figure 79. Maximum 3 State Transitions into Given State

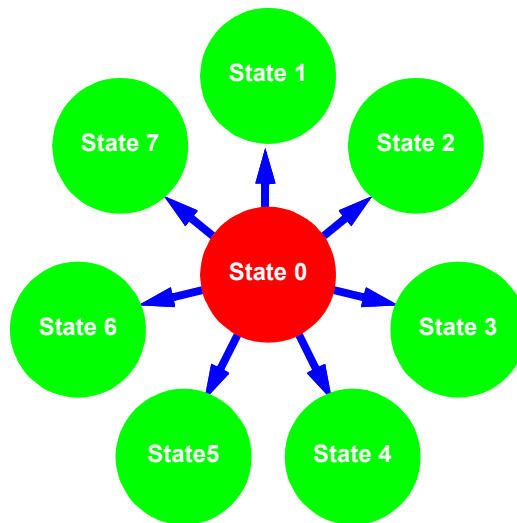

Figure 80. Maximum 7 State Transitions out of a Given State

18.3 ASM Outputs

There are a total of 8 outputs from the ASM macrocell, which go to the Connections Matrix inputs, and from there can be routed to other internal macrocells or pins. The 8 outputs are user defined for each of the possible 8 states, this information is held in the Connection Matrix Output RAM, shown in *Figure 81*. . The Connection Matrix Output RAM has a total of 64 bits, arranged as 8 bits per state. The values loaded in each of the 8 bits define the signal level on each of the 8 ASM macrocell outputs.

The ASM Editor inside the GPAK Designer software allows the user to make their selections for the value of each bit in the Connection Matrix Output RAM, which selects the level of the macrocell outputs based on the current state of the ASM macrocell, as shown in *Figure 81*. .

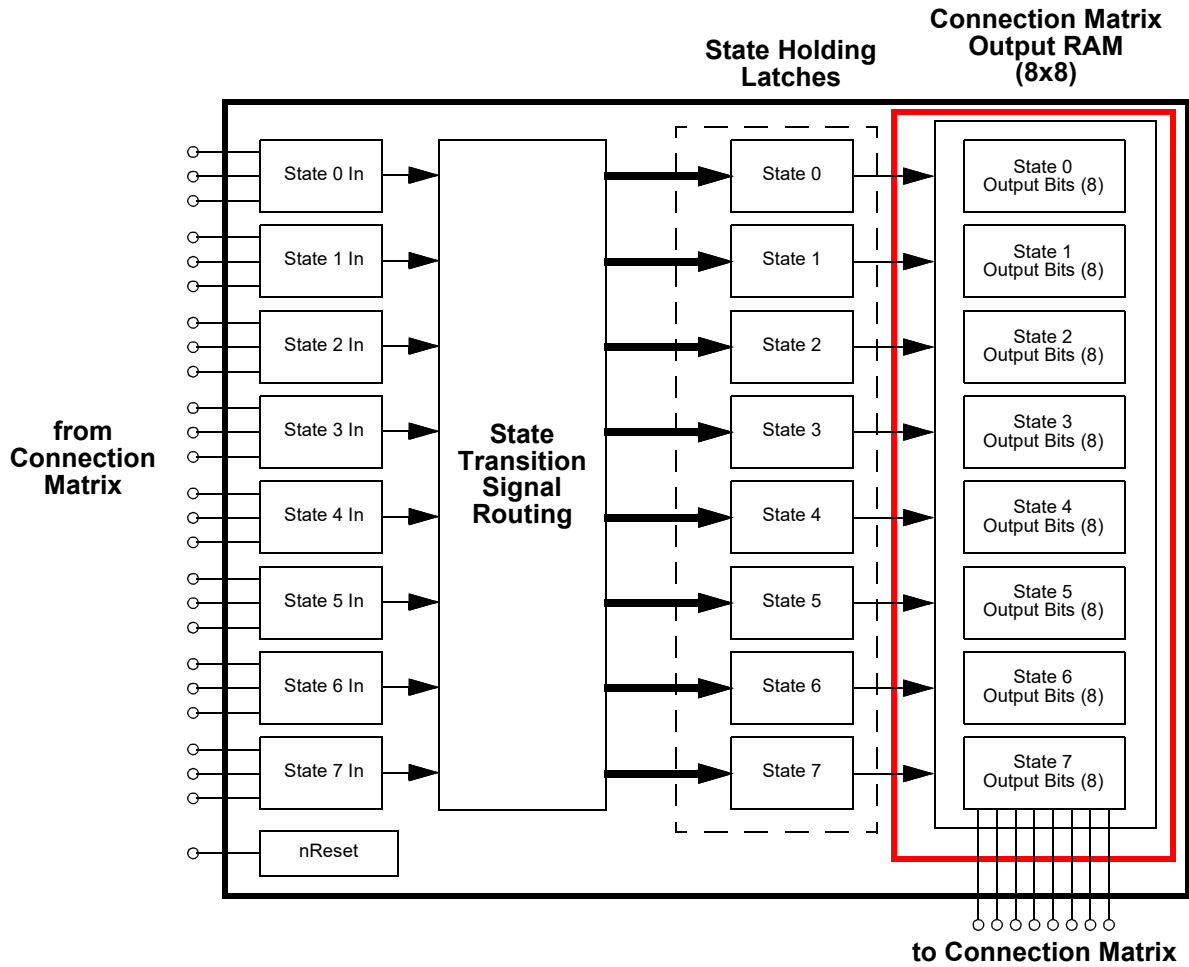

Figure 81. Connection Matrix Output RAM

Table 84. ASM Editor - Connection Matrix Output RAM

| RAM | | | | | | | | |
|------------|------------------------------|------|------|------|------|------|------|------|
| State name | Connection Matrix Output RAM | | | | | | | |
| | OUT7 | OUT6 | OUT5 | OUT4 | OUT3 | OUT2 | OUT1 | OUT0 |
| State 0 | 0 | 0 | 0 | 0 | 0 | 0 | 0 | 1 |
| State 1 | 0 | 0 | 0 | 0 | 0 | 0 | 1 | 0 |
| State 2 | 0 | 0 | 0 | 0 | 0 | 1 | 0 | 0 |
| State 3 | 0 | 0 | 0 | 0 | 1 | 0 | 0 | 0 |
| State 4 | 0 | 0 | 0 | 1 | 0 | 0 | 0 | 0 |
| State 5 | 0 | 0 | 1 | 0 | 0 | 0 | 0 | 0 |
| State 6 | 0 | 1 | 0 | 0 | 0 | 0 | 0 | 0 |
| State 7 | 1 | 0 | 0 | 0 | 0 | 0 | 0 | 0 |

There is a possibility to configure ASM (it's settings and transitions) via I²C. Registers (reg<197:0>) correspond for ASM inputs, registers (reg<1727:1664>) correspond for ASM outputs configuration. Using I²C commands (see section 19.4 I2C Serial Communications Commands) it is possible to read ASM settings and connections, as well as change them. Additionally, user can change Connection Matrix Output RAM bit configuration (bytes 0xD0...0xD7)

Note: After Connection Matrix Output RAM was updated via I²C, ASM outputs to Connection Matrix can be changed only after ASM changes its state or after reset event. To change ASM outputs to Connection Matrix instantly after I²C write command, ASM must be in reset all the time.

18.4 Basic ASM Timing

The basic state transition timing from input on Matrix Connection output to output on Matrix Connection input is shown in *Figure 82.* and *Figure 83.* . The time from a valid input signal to the time that there is a valid change of state and valid signals being available on the state outputs is State Machine Output Delay Time ($T_{st_out_delay}$). The minimum and maximum values of $T_{st_out_delay}$ define the differential timing between the shortest state transition (input on matrix output and output on matrix input) and the longest state transition (input on matrix output and output on matrix input).

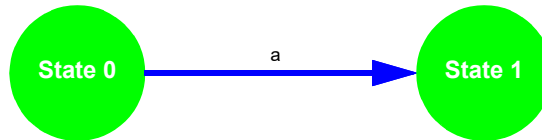

Figure 82. State Transition

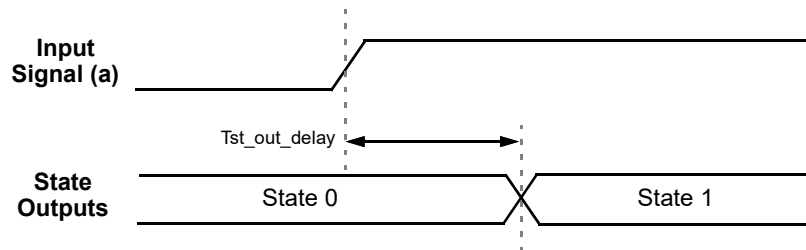

Figure 83. State Transition Timing

18.5 Asynchronous State Machines vs. Synchronous State Machines

It is important to note that this macrocell is designed for asynchronous operation, which means the following:

1. No clock source is needed, it reacts only to input signals
2. The input signals do not have to be synchronized to each other, the macrocell will react to the earliest valid signal for state transition.
3. This macrocell does not have traditional set-up and hold time specifications which are related to incoming clock, as this macrocell has no clock source.
4. The macrocell only consumes power while in state transition.

18.6 ASM Power Considerations

A benefit of the asynchronous nature of this macrocell is that it will consume power only during state transitions. Shown in *Figure 82.* and *Figure 84.* below, the current consumption of the macrocell will be a fraction of a μA between state transitions, and will rise only during state transitions. See Section 5.7 IDD Estimator to find average current during state transitions.

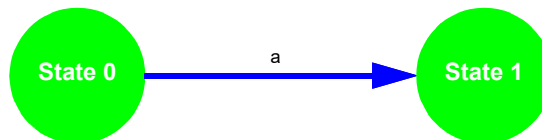

Figure 84. State Transition

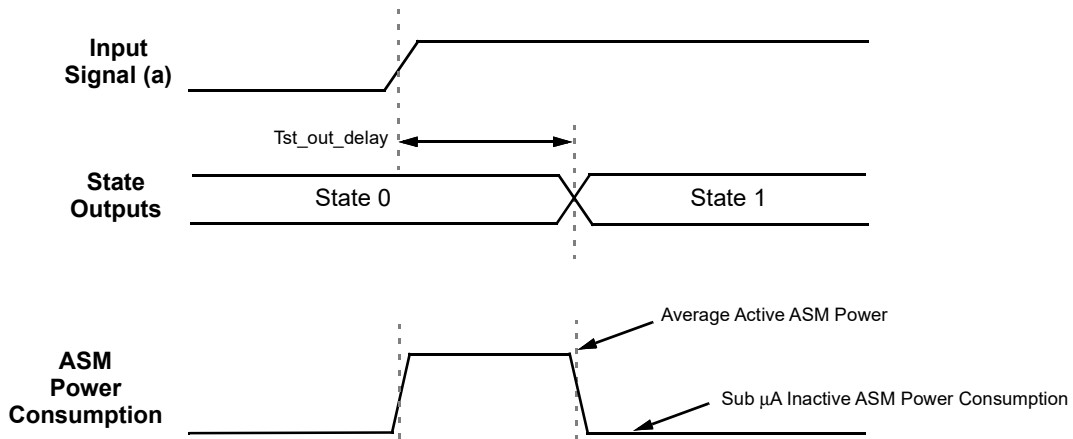

Figure 85. State Transition Timing and Power Consumption

18.7 ASM Logical vs. Physical Design

A successful design with the ASM macrocell must include both the logic level design as well as the physical level design. The GPAK Designer development software support user designs for the ASM macrocell at both the logic level and physical level. The logic level design of the user defined state machine takes place inside the ASM Editor. In the ASM Editor, the user can select and name states, define and name allowed state transitions, define the Initial / Reset state and define the output values for the 8 outputs in the Output RAM Matrix. The physical level design takes place in the general GPAK Designer window, and here the user makes connections for the sources for ASM input signals, as well as making connections for destinations for ASM output signals.

18.8 ASM Special Case Timing Considerations

18.8.1 State Transition Pulse Input Timing

All inputs to the ASM macrocell are level sensitive. If the input to the state machine macrocell for a state transition is a pulse, there is a minimum pulse width on the input to the state machine macrocell (as measured at the matrix input to the macrocell) which is guaranteed to result in a state transition shown in Figure 86. and Figure 87. . This pulse width is defined by the State Machine Input Pulse Acceptance Time (Tst_pulse). If a pulse width that is shorter than Tst_pulse is input to the state machine macrocell, it is indeterminate whether the state transition will happen or not. If a pulse that is rejected (invalid due to the pulse width being narrower than the guaranteed minimum of Tst_pulse), this will not stop a valid pulse on another state transition input that does meet minimum pulse width.

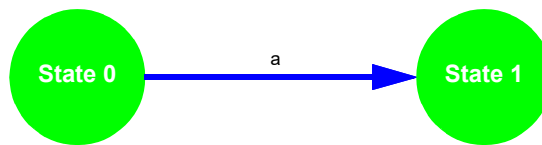

Figure 86. State Transition

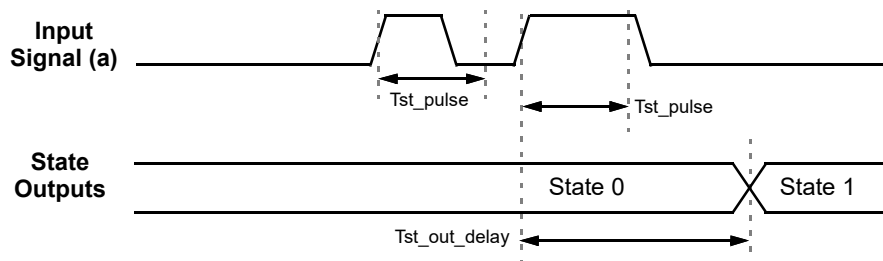

Figure 87. State Transition Pulse Input Timing

18.8.2 State Transition Competing Input Timing

There will be situations where two input signals can be valid inputs that will drive two different state transitions from a given state. In that sense, the two signals are “competing” (signals a and b in *Figure 88*), and the signal that arrives sooner should drive the state transition that will “win”, or drive the state transition. If one signal arrives T_{st_comp} before the other one, it is guaranteed to win, and the state transition that it codes for will be taken, as shown in *Figure 89* . If the two signals arrive within T_{st_comp} of each other, it will be indeterminate which state transition will win, but one of the transitions will take place as long as the winning signal satisfies the pulse width criteria described in the paragraph above, as shown in *Figure 90* .

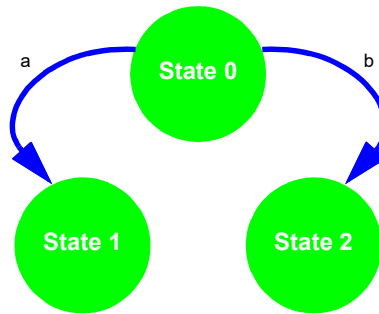

Figure 88. State Transition - Competing Inputs

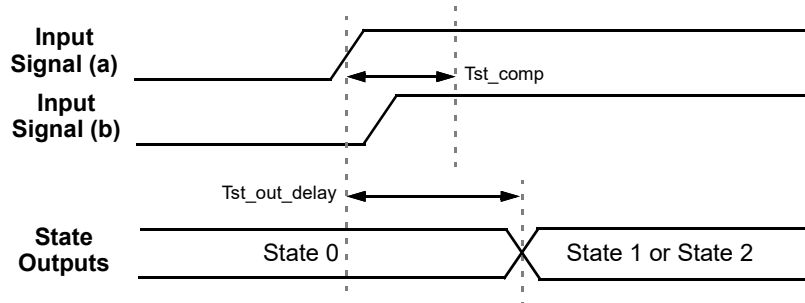

Figure 89. State Transition Timing - Competing Inputs Indeterminate

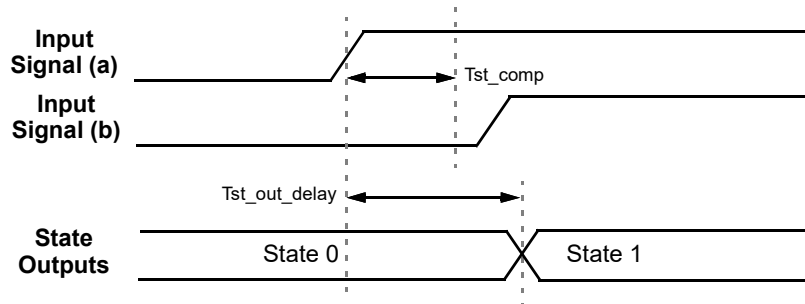

Figure 90. State Transition Timing - Competing Inputs Determinable

18.8.3 ASM State Transition Sequential Timing

It is possible to have a valid input signal for a transition out from a particular state be active before the state is active. If this is the case, the macrocell will only stay in that particular state for $T_{st_out_delay}$ time before making the transition to the next state. An example of this sequential behavior is shown in *Figure 91*. and the associated timing is shown in *Figure 92*.

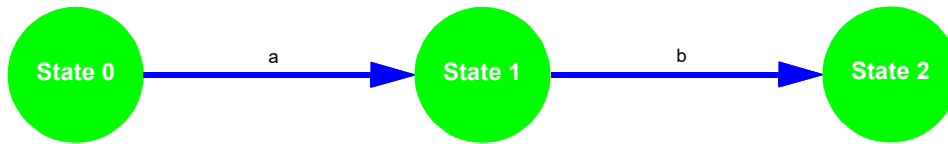

Figure 91. State Transition - Sequential

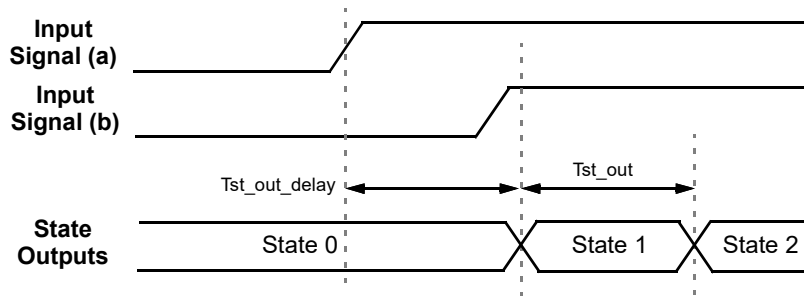

Figure 92. State Transition - Sequential Timing

18.8.4 State Transition Closed Cycling

It is possible to have a closed cycle of state transitions that will run continuously if there are valid inputs that are active at the same time. The rate at which the state transitions will take place is determined by $T_{st_out_delay}$. The example shown here in *Figure 93*. involves cycling between two states, but any number of two – eight states can be included in state transition closed cycling of this nature. *Figure 94*. shows the associated timing for closed cycling.

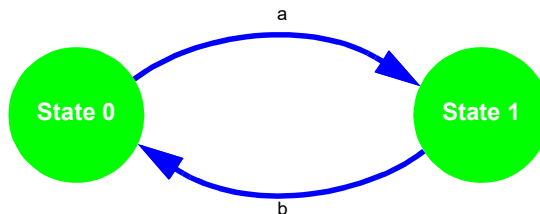

Figure 93. State Transition - Closed Cycling

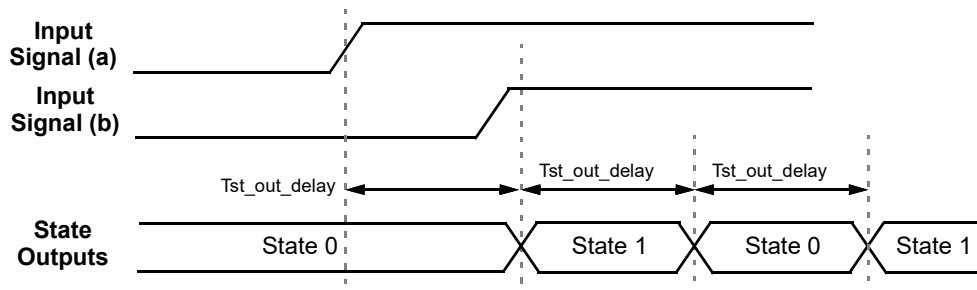

Figure 94. State Transition - Closed Cycling Timing

19.0 I²C Serial Communications Macrocell

19.1 I²C Serial Communications Macrocell Overview

In the standard use case for the GreenPAK devices, the configuration choices made by the user are stored as bit settings in the Non-Volatile Memory (NVM), and this information is transferred at startup time to volatile RAM registers that enable the configuration of the macrocells. Other RAM registers in the device are responsible for setting the connections in the Connection Matrix to route signals in the manner most appropriate for the user’s application.

The I²C Serial Communications Macrocell in this device allows an I²C bus Master to read and write this information via a serial channel directly to the RAM registers, allowing the remote re-configuration of macrocells, and remote changes to signal chains within the device.

An I²C bus Master is also able read and write other I²C register bits that are not associated with NVM memory. As an example, the input lines to the Connection Matrix can be read as digital register bits. These are the signal outputs of each of the macrocells in the device, giving an I²C bus Master the capability to remotely read the current value of any macrocell.

The user has the flexibility to control read access and write access via registers bits reg<1832>, reg<1870>, and reg<1871>. See section 19.5 I²C Serial Command Register Protection for more details on I²C read/write memory protection.

Note: GreenPAK I²C is fully compatible with standard I²C protocol.

19.2 I²C Serial Communications Device Addressing

Each command to the I²C Serial Communications macrocell begins with a Control Byte. The bits inside this Control Byte are shown in Figure 95. After the Start bit, the first four bits are a control code, which can be set by the user in reg<1867:1864>. This gives the user flexibility on the chip level addressing of this device and other devices on the same I²C bus. The Block Address is the next three bits (A10,A9, A8), which will define the most significant bits in the addressing of the data to be read or written by the command. The last bit in the Control Byte is the R/W bit, which selects whether a read command or write command is requested, with a “1” selecting for a Read command, and a “0” selecting for a Write command. This Control Byte will be followed by an Acknowledge bit (ACK), which is sent by this device to indicate successful communication of the Control Byte data.

In the I²C-bus specification and user manual, there are two groups of eight addresses (0000 xxx and 1111 xxx) that are reserved for the special functions, such as a system General Call address. If the user of this device choses to set the Control Code to either “1111” or “0000” in a system with other slave device, please consult the I²C-bus specification and user manual to understand the addressing and implementation of these special functions, to ensure reliable operation.

In the read and write command address structure, there are a total of 11 bits of addressing, each pointing to a unique byte of information, resulting in a total address space of 2K bytes. Of this 2K byte address space, the valid addresses accessible to the I²C Macrocell on the SLG46534 are in the range from 0 (0x00) to 255 (0xFF). The MSB address bits (A10, A9 and A8) will be “0” for all commands to the SLG46534.

With the exception of the Current Address Read command, all commands will have the Control Byte followed by the Word Address. Figure 95. shows this basic command structure.

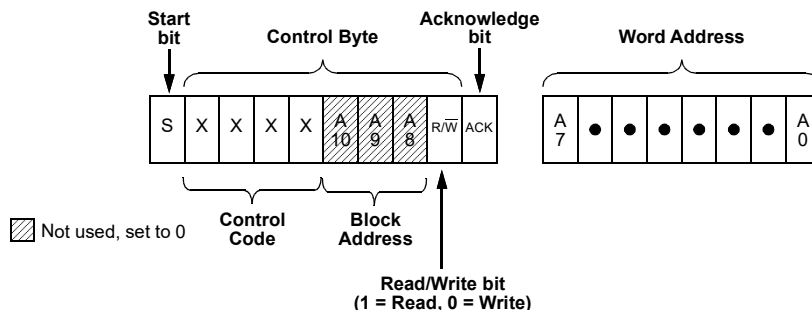

Figure 95. Basic Command Structure

19.3 I²C Serial General Timing

General timing characteristics for the I²C Serial Communications macrocell are shown in Figure 96. . Timing specifications can be found in the AC Characteristics section.

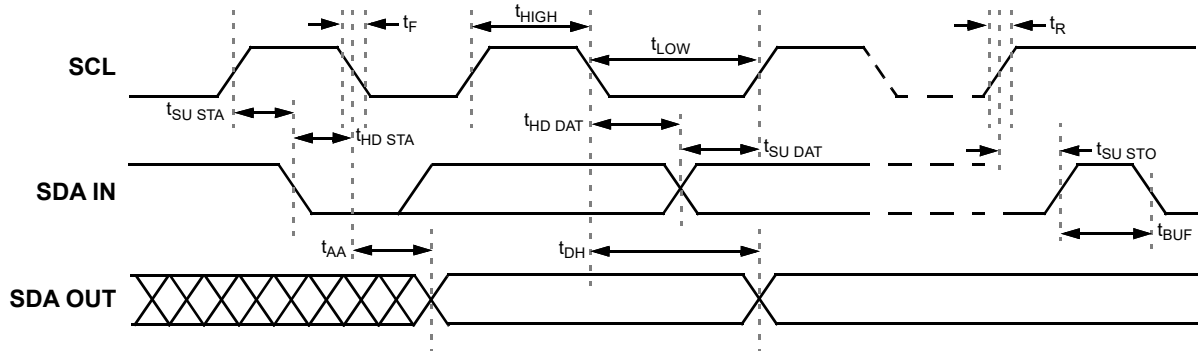

Figure 96. I²C General Timing Characteristics

19.4 I²C Serial Communications Commands

19.4.1 Byte Write Command

Following the Start condition from the Master, the Control Code [4 bits], the Block Address [3 bits] and the R/W bit (set to “0”), are placed onto the I²C bus by the Master. After the SLG46534 sends an Acknowledge bit (ACK), the next byte transmitted by the Master is the Word Address. The Block Address (A10, A9, A8), combined with the Word Address (A7 through A0), together set the internal address pointer in the SLG46534 where the data byte is to be written. After the SLG46534 sends another Acknowledge bit, the Master will transmit the data byte to be written into the addressed memory location. The SLG46534 again provides an Acknowledge bit and then the Master generates a Stop condition. The internal write cycle for the data will take place at the time that the SLG46534 generates the Acknowledge bit.

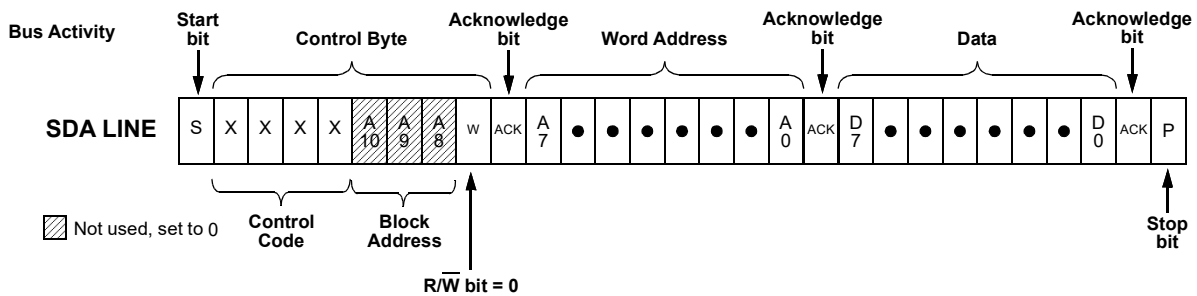

Figure 97. Byte Write Command, R/W = 0

19.4.2 Sequential Write Command

The write Control Byte, Word Address and the first data byte are transmitted to the SLG46534 in the same way as in a Byte Write command. However, instead of generating a Stop condition, the Master continues to transmit data bytes to the SLG46534. Each subsequent data byte will increment the internal address counter, and will be written into the next higher byte in the command addressing. As in the case of the Byte Write command, the internal write cycle will take place at the time that the SLG46534 generates the Acknowledge bit.

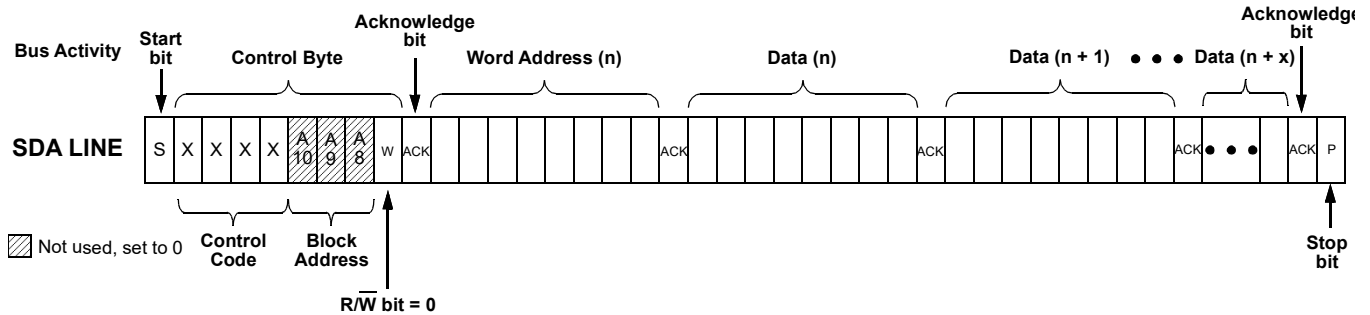

Figure 98. Sequential Write Command, $\overline{R/W} = 0$

19.4.3 Current Address Read Command

The Current Address Read Command reads from the current pointer address location. The address pointer is incremented at the first STOP bit following any write control byte. For example, if a Write or Random Read (which contains a write control byte) writes or reads data up to address n, the address pointer would get incremented to n+1 upon the STOP of that command. Subsequently, a Current Address Read that follows would start reading data at n+1. The Current Address Read Command contains the Control Byte sent by the Master, with the R/W bit = "1". The SLG46534 will issue an Acknowledge bit, and then transmit eight data bits for the requested byte. The Master will not issue an Acknowledge bit, and follow immediately with a Stop condition.

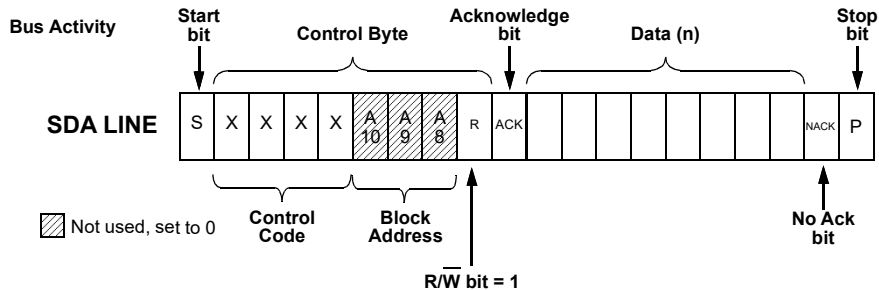

Figure 99. Current Address Read Command, $\overline{R/W} = 1$

19.4.4 Random Read Command

The Random Read command starts with a Control Byte (with $\overline{R/W}$ bit set to “0”, indicating a write command) and Word Address to set the internal byte address, followed by a Start bit, and then the Control Byte for the read (exactly the same as the Byte Write command). The Start bit in the middle of the command will halt the decoding of a Write command, but will set the internal address counter in preparation for the second half of the command. After the Start bit, the Master issues a second control byte with the $\overline{R/W}$ bit set to “1”, after which the SLG46534 issues an Acknowledge bit, followed by the requested eight data bits.

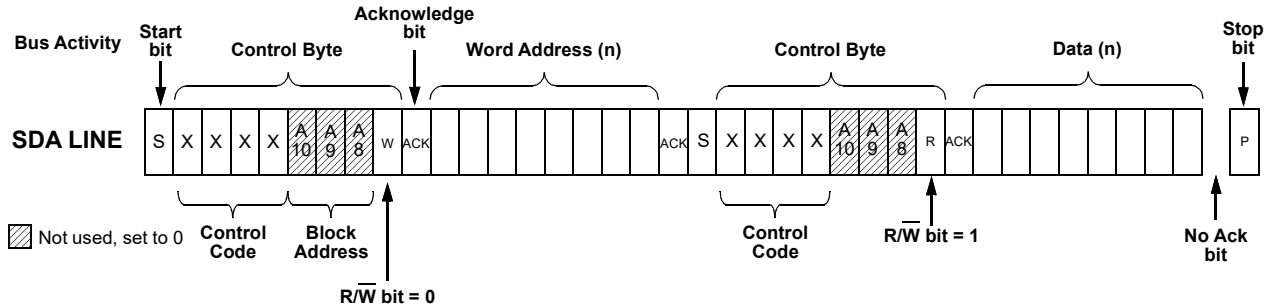

Figure 100. Random Read Command

19.4.5 Sequential Read Command

The Sequential Read command is initiated in the same way as a Current Address Read or Random Read command, except that once the SLG46534 transmits the first data byte, the Master issues an Acknowledge bit as opposed to a Stop condition in a random read. The Master can continue reading sequential bytes of data, and will terminate the command with a Stop condition.

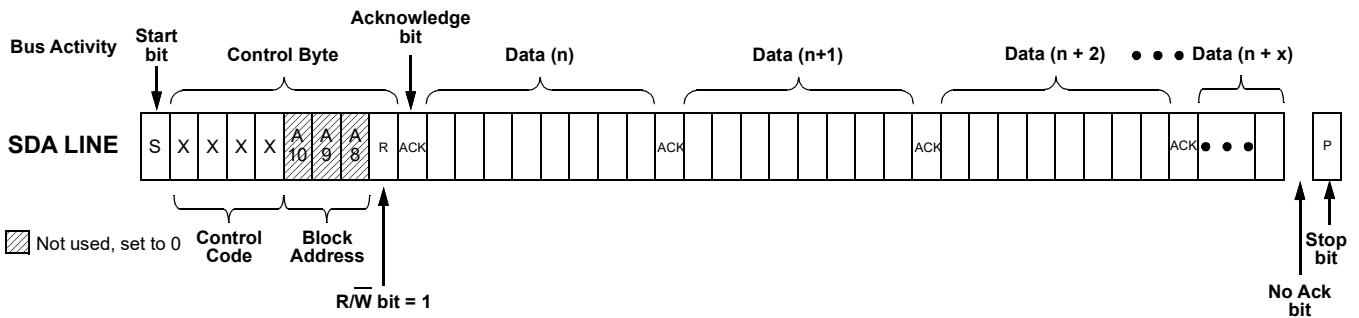

Figure 101. Sequential Read Command

19.4.6 I²C Serial Command Register Map

These register addresses are broken down into four Banks to give the user greater control on access to reading and writing information in each bank. Each of the four banks is 512 bits (64 bytes) in length. Writing information to register bits in these Banks will change the configuration of the device, resulting in either a change in the interconnection options provided by the Connection Matrix, or by changing the configuration of individual macrocells. During device use, all register bits can be read or written via I²C, unless protection bits are set to prevent this.

See Section 21.0 Appendix A - SLG46534 Register Definition for detailed information on all register bits

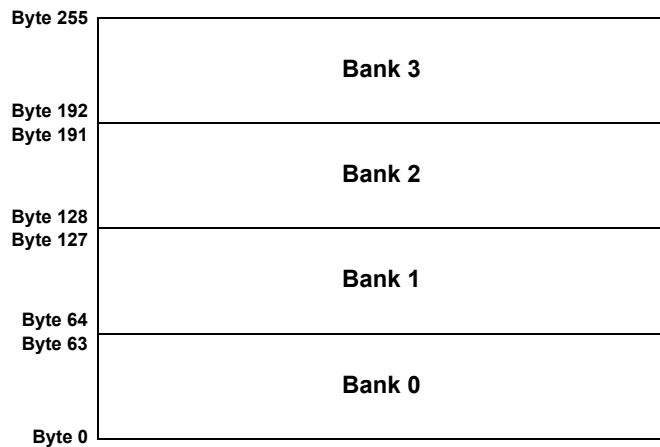

Figure 102. Register Bank Map

19.5 I²C Serial Command Register Protection

The memory space is divided into four banks, each of which has 512bits (64bytes). There are three bits that allow the user to define rules for reading and writing bits in each of these banks via I²C:

- reg<1832> I²C lock for read bits <1535:0> (Bank 0/1/2). If the system provides any read commands to the addresses in these three banks, the device will respond with 'FFH' in data field.
- reg<1871> I²C lock for write bits <1535:0> (Bank 0/1/2). If the system provides any write commands to the addresses in these three banks, the device will acknowledge these commands, but will not do internal writes to the register space.
- reg<1870> I²C lock for write all bits (Bank 0/1/2/3). If the system provides any write commands to the addresses in these four banks, the device will acknowledge these commands, but will not do internal writes to the register space.

Note 1. reg<1870> is higher priority than reg<1871>, and if reg<1870> is set, than reg<1871> does not have any effect.

Note 2. If the user sets Pins 8 and 9 function to a selection other than SDA and SCL, all access via I²C will be disabled.

If reg <1870> is not set, register bits in Bank 3 are open to read and write commands via I²C with the following exceptions:

- reg<1871> Bank 0/1/2 I²C-write protection bit is always protected from I²C write
- reg<1867:1864> I²C Control Code Bit [3:0] is always protected from I²C write

Note 4. Any write commands that come to the device via I²C that are not blocked, based on the protection bits, will change the contents of the RAM register bits that mirror the NVM bits. These write commands will not change the NVM bits themselves, and a POR event will restore the register bits to original programmed contents of the NVM.

See Section 21.0 Appendix A - SLG46534 Register Definition for detailed information on all registers.

19.5.1 Register Read/Write Protection

There are six read/write protect modes for the design sequence from being corrupted or copied. See *Table 85* for details..

Table 85. Read/Write Protection Options

| Bank | Byte | Bits | Description | Lock Status | | | | | |
|------|---------|-----------------|--|----------------------------------|----------------------------------|----------------------------------|----------------------------------|---|--|
| | | | | Unlocked | Locked for read bits <1535:0> | Locked for write bits <1535:0> | Locked for write all bits | Locked for read and write bits <1535:0> | Locked for read bits <1535:0> and write all bits |
| | | | | reg <1832>=0, <1871>=0, <1870>=0 | reg <1832>=1, <1871>=0, <1870>=0 | reg <1832>=0, <1871>=1, <1870>=0 | reg <1832>=0, <1871>=x, <1870>=1 | reg <1832>=1, <1871>=1, <1870>=0 | reg <1832>=1, <1871>=x, <1870>=1 |
| 0 | 0-63 | 511-0 | Connection Matrix Outputs Configuration | R/W | W | R | R | - | - |
| | 1 | 64-109 | | 879-512 | R/W | W | R | R | - |
| | 110-127 | 880-1023 | Reserved | - | - | - | - | - | - |
| 2 | 128-186 | 1495-1024 | Function Configuration for PINs, LUTs/DFFs, OSC, ASM and some configuration for DLYs, ACMP | R/W | W | R | R | - | - |
| | 187-191 | 1535-1496 | Reserved | - | - | - | - | - | - |
| 3 | 192-206 | 1655-1536 | CNT/DLY counter data and some LUTs truth table, ACMP Vref | R/W | R/W | R/W | R | R/W | R |
| | 207 | 1662 | I ² C reset bit with reloading NVM into Data register | R/W | R/W | R/W | R | R/W | R |
| | | 1661-1659, 1663 | Reserved | R | R | R | R | R | R |
| | | 1658-1656 | OSC Power Control | R/W | R/W | R/W | R | R/W | R |

Table 85. Read/Write Protection Options

| Bank | Byte | Bits | Description | Lock Status | | | | | |
|---------|-----------|---|---|----------------------------------|----------------------------------|----------------------------------|----------------------------------|---|--|
| | | | | Unlocked | Locked for read bits <1535:0> | Locked for write bits <1535:0> | Locked for write all bits | Locked for read and write bits <1535:0> | Locked for read bits <1535:0> and write all bits |
| | | | | reg <1832>=0, <1871>=0, <1870>=0 | reg <1832>=1, <1871>=0, <1870>=0 | reg <1832>=0, <1871>=1, <1870>=0 | reg <1832>=0, <1871>=x, <1870>=1 | reg <1832>=1, <1871>=1, <1870>=0 | reg <1832>=1, <1871>=x, <1870>=1 |
| 3 | 208-223 | 1791-1664 | ASM output RAM and User configurable RAM / OTP | R/W | R/W | R/W | R | R/W | R |
| | 224-227 | 1823-1792 | Reserved | - | - | - | - | - | - |
| | 228 | 1831-1824 | Reserved | R/W | R/W | R/W | R | R/W | R |
| | 229 | 1839-1836 | Product Family ID | R | R | R | R | R | R |
| | | 1835-1834 | Reserved | - | - | - | - | - | - |
| | | 1833 | Reserved | R | R | R | R | R | R |
| | | 1832 | I ² C Lock for read bits<1535:0> | R | R | R | R | R | R |
| | 230 | 1847-1840 | Pattern ID | R/W | R/W | R/W | R | R/W | R |
| | 231 | 1855-1848 | Reserved | R | R | R | R | R | R |
| | 232 | 1863-1856 | Reserved | R | R | R | R | R | R |
| | 233 | 1871 | I ² C Lock for write bits<1535:0> | R | R | R | R | R | R |
| | | 1870 | I ² C Lock for write all bits | R | R | R | R | R | R |
| | | 1869-1868 | Reserved | - | - | - | - | - | - |
| | | 1867-1864 | I ² C Control Code | R | R | R | R | R | R |
| | 234-239 | 1919-1872 | Counter Current Value | R | R | R | R | R | R |
| | 240-243 | 1951-1920 | Macrocells Output Values (Connection Matrix Inputs) | R | R | R | R | R | R |
| | 244 | 1959-1952 | Connection Matrix Virtual Inputs | R/W | R/W | R/W | R | R/W | R |
| 245-247 | 1983-1960 | Macrocells Output Values (Connection Matrix Inputs) | R | R | R | R | R | R | |
| 248-250 | 2007-1984 | Reserved | R | R | R | R | R | R | |

Table 85. Read/Write Protection Options

| Bank | Byte | Bits | Description | Lock Status | | | | | |
|------|---------|-----------|-------------|----------------------------------|----------------------------------|----------------------------------|----------------------------------|---|--|
| | | | | Unlocked | Locked for read bits <1535:0> | Locked for write bits <1535:0> | Locked for write all bits | Locked for read and write bits <1535:0> | Locked for read bits <1535:0> and write all bits |
| | | | | reg <1832>=0, <1871>=0, <1870>=0 | reg <1832>=1, <1871>=0, <1870>=0 | reg <1832>=0, <1871>=1, <1870>=0 | reg <1832>=0, <1871>=x, <1870>=1 | reg <1832>=1, <1871>=1, <1870>=0 | reg <1832>=1, <1871>=x, <1870>=1 |
| 3 | 251 | 2015-2008 | Reserved | R/W | R/W | R/W | R | R/W | R |
| | 252-253 | 2031-2016 | Reserved | R | R | R | R | R | R |
| | 254 | 2039-2032 | Reserved | R/W | R/W | R/W | R | R/W | R |
| | 255 | 2047-2040 | Reserved | R/W | R/W | R/W | R | R/W | R |

| | |
|-----|--|
| R/W | Allow Read and Write Data |
| W | Allow Write Data Only |
| R | Allow Read Data Only |
| - | The Data is protected for Read and Write |

19.5.1.1 I²C Serial Reset Command

If I²C serial communication is established with the device, it is possible to reset the device to initial power up conditions, including configuration of all macrocells, and all connections provided by the Connection Matrix. This is implemented by setting reg<1662> I²C reset bit to “1”, which causes the device to re-enable the Power On Reset (POR) sequence, including the reload of all register data from NVM. During the POR sequence, the outputs of the device will be in tri-state. After the reset has taken place, the contents of reg<1662> will be set to “0” automatically. The timing diagram shown below illustrates the sequence of events for this reset function.

Note: I²C Serial Reset Command is not available during emulation.

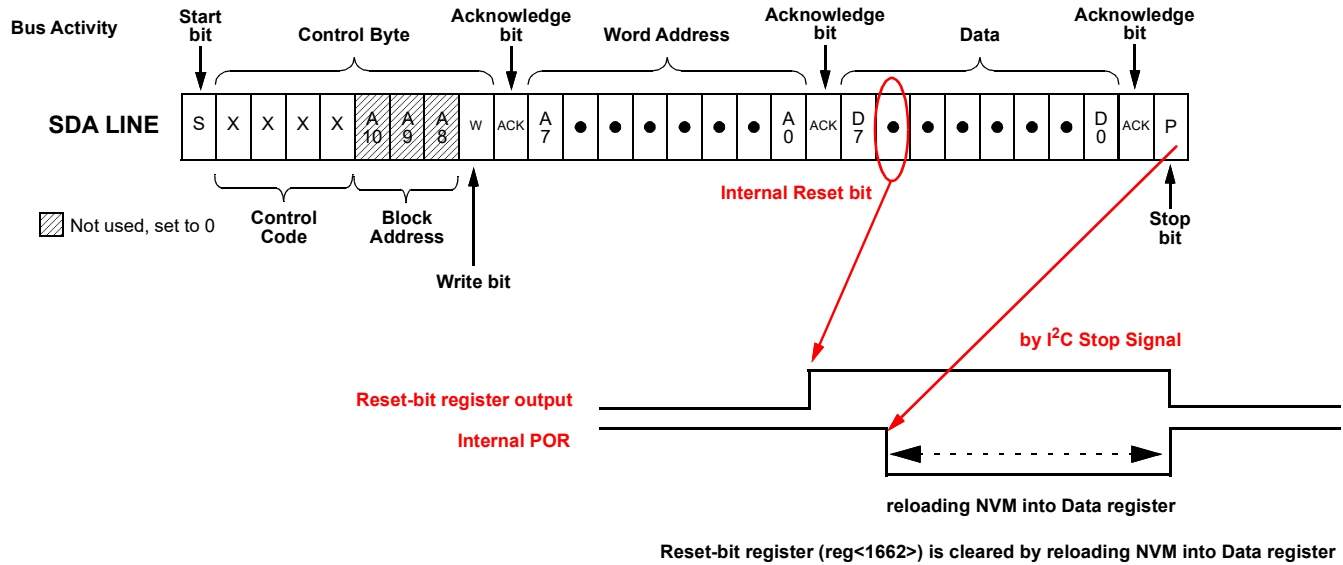

- 1) I²C write with reg<1662>=1 (I²C reset bit with reloading NVM into Data register)
- 2) POR go to LOW and reloading NVM into Data register start after "STOP" of I²C
- 3) POR go to HIGH after reloading NVM into Data register

Figure 103. Reset Command Timing

19.5.1.2 Reading Counter Data via I²C

The current count value in four counters in the device can be read via I²C. The counters that have this additional functionality are 16-bit CNT0 and CNT1, and 8-bit counters CNT4 and CNT6.

19.5.1.3 User RAM and OTP Memory Array

There are eight bytes of RAM memory that can be read and written remotely by I²C commands. The initial contents of this memory space can be selected by the user, and this information will be transferred from OTP memory to the RAM memory space during the power-up sequence. The lowest order byte in this array (User Configurable RAM/OTP Byte 0) is located at I²C address 0xD8, and the highest order byte in this array is located at I²C address 0xDF.

Table 86. RAM Array Table

| I ² C Address (hex) | Highest Bit Address | Lowest Bit Address | Memory Byte |
|--------------------------------|---------------------|--------------------|----------------------------------|
| D8 | 1735 | 1728 | User Configurable RAM/OTP Byte 0 |
| D9 | 1743 | 1736 | User Configurable RAM/OTP Byte 1 |
| DA | 1751 | 1744 | User Configurable RAM/OTP Byte 2 |
| DB | 1759 | 1752 | User Configurable RAM/OTP Byte 3 |
| DC | 1767 | 1760 | User Configurable RAM/OTP Byte 4 |
| DD | 1775 | 1768 | User Configurable RAM/OTP Byte 5 |
| DE | 1783 | 1776 | User Configurable RAM/OTP Byte 6 |
| DF | 1791 | 1784 | User Configurable RAM/OTP Byte 7 |

20.0 External Clocking

The SLG46534 supports several ways to use an external, higher accuracy clock as a reference source for internal operations

20.1 Crystal Mode

When reg<1136> is set to 1, an external crystal can be connected to pins 12 and 13 for supplying an accurate clock source. See section 16.0 Crystal Oscillator. An external clocking signal on pin 13 can be used in place of the crystal. The high and low limits for crystal frequency that can be selected are 32.768 kHz and 40 MHz.

20.2 Pin 14 Source for 25 KHz / 2 MHz Clock

When reg<1358> is set to 1, an external clocking signal on pin 14 will be routed in place of the internal RC oscillator derived 25 kHz/2 MHz clock source. See *Figure 62*. . The high and low limits for external frequency that can be selected are 0 MHz and 77 MHz.

20.3 Pin 13 Source for 25 MHz Clock

When reg<1357> is set to 1, an external clocking signal on pin 13 will be routed in place of the internal RC oscillator derived 25 MHz clock source. See *Figure 63*. . The high and low limits for external frequency that can be selected are 0 MHz and 84 MHz.

21.0 Appendix A - SLG46534 Register Definition

| Address | | Signal Function | Register Bit Definition | I ² C Interface | |
|---|--------------|-----------------|-------------------------|----------------------------|-------|
| Byte | Register Bit | | | Read | Write |
| Note: For reg<0> to reg<1495>, I²C Read is valid (assuming reg <1832> = 0), I²C Write is valid (assuming reg <1871> = 0) | | | | | |
| Matrix 64-to-1 MUX's 6 selection bits | | | | | |
| 00 | reg<5:0> | Matrix OUT | ASM-state0-EN0 | Valid | Valid |
| | reg<7:6> | Reserved | | Valid | Valid |
| 01 | reg<13:8> | Matrix OUT | ASM-state0-EN1 | Valid | Valid |
| | reg<15:14> | Reserved | | Valid | Valid |
| 02 | reg<21:16> | Matrix OUT | ASM-state0-EN2 | Valid | Valid |
| | reg<23:22> | Reserved | | Valid | Valid |
| 03 | reg<29:24> | Matrix OUT | ASM-state1-EN0 | Valid | Valid |
| | reg<31:30> | Reserved | | Valid | Valid |
| 04 | reg<37:32> | Matrix OUT | ASM-state1-EN1 | Valid | Valid |
| | reg<39:38> | Reserved | | Valid | Valid |
| 05 | reg<45:40> | Matrix OUT | ASM-state1-EN2 | Valid | Valid |
| | reg<47:46> | Reserved | | Valid | Valid |
| 06 | reg<53:48> | Matrix OUT | ASM-state2-EN0 | Valid | Valid |
| | reg<55:54> | Reserved | | Valid | Valid |
| 07 | reg<61:56> | Matrix OUT | ASM-state2-EN1 | Valid | Valid |
| | reg<63:62> | Reserved | | Valid | Valid |
| 08 | reg<69:64> | Matrix OUT | ASM-state2-EN2 | Valid | Valid |
| | reg<71:70> | Reserved | | Valid | Valid |
| 09 | reg<77:72> | Matrix OUT | ASM-state3-EN0 | Valid | Valid |
| | reg<79:78> | Reserved | | Valid | Valid |
| 0A | reg<85:80> | Matrix OUT | ASM-state3-EN1 | Valid | Valid |
| | reg<87:86> | Reserved | | Valid | Valid |
| 0B | reg<93:88> | Matrix OUT | ASM-state3-EN2 | Valid | Valid |
| | reg<95:94> | Reserved | | Valid | Valid |
| 0C | reg<101:96> | Matrix OUT | ASM-state4-EN0 | Valid | Valid |
| | reg<103:102> | Reserved | | Valid | Valid |
| 0D | reg<109:104> | Matrix OUT | ASM-state4-EN1 | Valid | Valid |
| | reg<111:110> | Reserved | | Valid | Valid |
| 0E | reg<117:112> | Matrix OUT | ASM-state4-EN2 | Valid | Valid |
| | reg<119:118> | Reserved | | Valid | Valid |
| 0F | reg<125:120> | Matrix OUT | ASM-state5-EN0 | Valid | Valid |
| | reg<127:126> | Reserved | | Valid | Valid |
| 10 | reg<133:128> | Matrix OUT | ASM-state5-EN1 | Valid | Valid |
| | reg<135:134> | Reserved | | Valid | Valid |
| 11 | reg<141:136> | Matrix OUT | ASM-state5-EN2 | Valid | Valid |
| | reg<143:142> | Reserved | | Valid | Valid |
| 12 | reg<149:144> | Matrix OUT | ASM-state6-EN0 | Valid | Valid |
| | reg<151:150> | Reserved | | Valid | Valid |

| Address | | Signal Function | Register Bit Definition | I ² C Interface | |
|---------|--------------|-----------------|---|----------------------------|-------|
| Byte | Register Bit | | | Read | Write |
| 13 | reg<157:152> | Matrix OUT | ASM-state6-EN1 | Valid | Valid |
| | reg<159:158> | Reserved | | Valid | Valid |
| 14 | reg<165:160> | Matrix OUT | ASM-state6-EN2 | Valid | Valid |
| | reg<167:166> | Reserved | | Valid | Valid |
| 15 | reg<173:168> | Matrix OUT | ASM-state7-EN0 | Valid | Valid |
| | reg<175:174> | Reserved | | Valid | Valid |
| 16 | reg<181:176> | Matrix OUT | ASM-state7-EN1 | Valid | Valid |
| | reg<183:182> | Reserved | | Valid | Valid |
| 17 | reg<189:184> | Matrix OUT | ASM-state7-EN2 | Valid | Valid |
| | reg<191:190> | Reserved | | Valid | Valid |
| 18 | reg<197:192> | Matrix OUT | ASM-state-RSTB | Valid | Valid |
| | reg<199:198> | Reserved | | Valid | Valid |
| 19 | reg<205:200> | Reserved | | Valid | Valid |
| | reg<207:206> | Reserved | | Valid | Valid |
| 1A | reg<213:208> | Reserved | | Valid | Valid |
| | reg<215:214> | Reserved | | Valid | Valid |
| 1B | reg<221:216> | Matrix OUT | PIN3 Digital Output Source | Valid | Valid |
| | reg<223:222> | Reserved | | Valid | Valid |
| 1C | reg<229:224> | Reserved | | Valid | Valid |
| | reg<231:230> | Reserved | | Valid | Valid |
| 1D | reg<237:232> | Reserved | | Valid | Valid |
| | reg<239:238> | Reserved | | Valid | Valid |
| 1E | reg<245:240> | Matrix OUT | PIN4 Digital Output Source | Valid | Valid |
| | reg<247:246> | Reserved | | Valid | Valid |
| 1F | reg<253:248> | Matrix OUT | PIN5 Digital Output Source | Valid | Valid |
| | reg<255:254> | Reserved | | Valid | Valid |
| 20 | reg<261:256> | Matrix OUT | PIN5 Output Enable | Valid | Valid |
| | reg<263:262> | Reserved | | Valid | Valid |
| 21 | reg<269:264> | Matrix OUT | PIN6 Digital Output Source (SCL with VI/In-put & NMOS open-drain) | Valid | Valid |
| | reg<271:270> | Reserved | | Valid | Valid |
| 22 | reg<277:272> | Matrix OUT | PIN7 Digital Output Source (SDA with VI/Input & NMOS open-drain) | Valid | Valid |
| | reg<279:278> | Reserved | | Valid | Valid |
| 23 | reg<285:280> | Matrix OUT | PIN8 Digital Output Source | Valid | Valid |
| | reg<287:286> | Reserved | | Valid | Valid |
| 24 | reg<293:288> | Matrix OUT | PIN8 Output Enable | Valid | Valid |
| | reg<295:294> | Reserved | | Valid | Valid |
| 25 | reg<301:296> | Matrix OUT | PIN10 Digital Output Source | Valid | Valid |
| | reg<303:302> | Reserved | | Valid | Valid |
| 26 | reg<309:304> | Reserved | | Valid | Valid |
| | reg<311:310> | Reserved | | Valid | Valid |

| Address | | Signal Function | Register Bit Definition | I ² C Interface | |
|---------|--------------|-----------------|---|----------------------------|-------|
| Byte | Register Bit | | | Read | Write |
| 27 | reg<317:312> | Reserved | | Valid | Valid |
| | reg<319:318> | Reserved | | Valid | Valid |
| 28 | reg<325:320> | Matrix OUT | PIN11 Digital Output Source | Valid | Valid |
| | reg<327:326> | Reserved | | Valid | Valid |
| 29 | reg<333:328> | Matrix OUT | PIN11 Output Enable | Valid | Valid |
| | reg<335:334> | Reserved | | Valid | Valid |
| 2A | reg<341:336> | Reserved | | Valid | Valid |
| | reg<343:342> | Reserved | | Valid | Valid |
| 2B | reg<349:344> | Matrix OUT | PIN12 Digital Output Source | Valid | Valid |
| | reg<351:350> | Reserved | | Valid | Valid |
| 2C | reg<357:352> | Matrix OUT | PIN12 Output Enable | Valid | Valid |
| | reg<359:358> | Reserved | | Valid | Valid |
| 2D | reg<365:360> | Matrix OUT | PIN13 Digital Output Source | Valid | Valid |
| | reg<367:366> | Reserved | | Valid | Valid |
| 2E | reg<373:368> | Reserved | | Valid | Valid |
| | reg<375:374> | Reserved | | Valid | Valid |
| 2F | reg<381:376> | Reserved | | Valid | Valid |
| | reg<383:382> | Reserved | | Valid | Valid |
| 30 | reg<389:384> | Reserved | | Valid | Valid |
| | reg<391:390> | Reserved | | Valid | Valid |
| 31 | reg<397:392> | Reserved | | Valid | Valid |
| | reg<399:398> | Reserved | | Valid | Valid |
| 32 | reg<405:400> | Matrix OUT | PIN14 Digital Output Source | Valid | Valid |
| | reg<407:406> | Reserved | | Valid | Valid |
| 33 | reg<413:408> | Matrix OUT | ACMP0 PDB (Power Down) | Valid | Valid |
| | reg<415:414> | Reserved | | Valid | Valid |
| 34 | reg<421:416> | Matrix OUT | ACMP1 PDB (Power Down) | Valid | Valid |
| | reg<423:422> | Reserved | | Valid | Valid |
| 35 | reg<429:424> | Matrix OUT | ACMP2 PDB (Power Down) | Valid | Valid |
| | reg<431:430> | Reserved | | Valid | Valid |
| 36 | reg<437:432> | Reserved | | Valid | Valid |
| | reg<439:438> | Reserved | | Valid | Valid |
| 37 | reg<445:440> | Matrix OUT | Input of Filter_0 with fixed time edge detector | Valid | Valid |
| | reg<447:446> | Reserved | | Valid | Valid |
| 38 | reg<453:448> | Matrix OUT | Input of Filter_1 with fixed time edge detector | Valid | Valid |
| | reg<455:454> | Reserved | | Valid | Valid |
| 39 | reg<461:456> | Matrix OUT | Input of Programmable Delay & Edge Detector | Valid | Valid |
| | reg<463:462> | Reserved | | Valid | Valid |
| 3A | reg<469:464> | Matrix OUT | OSC 25KHz/2MHz PDB (Power Down) | Valid | Valid |
| | reg<471:470> | Reserved | | Valid | Valid |

| Address | | Signal Function | Register Bit Definition | I ² C Interface | |
|---------|--------------|-----------------|--------------------------------------|----------------------------|-------|
| Byte | Register Bit | | | Read | Write |
| 3B | reg<477:472> | Matrix OUT | OSC 25MHz PDB (Power Down) | Valid | Valid |
| | reg<479:478> | Reserved | | Valid | Valid |
| 3C | reg<485:480> | Matrix OUT | IN0 of LUT2_0 or Clock Input of DFF0 | Valid | Valid |
| | reg<487:486> | Reserved | | Valid | Valid |
| 3D | reg<493:488> | Matrix OUT | IN1 of LUT2_0 or Data Input of DFF0 | Valid | Valid |
| | reg<495:494> | Reserved | | Valid | Valid |
| 3E | reg<501:496> | Matrix OUT | IN0 of LUT2_1 or Clock Input of DFF1 | Valid | Valid |
| | reg<503:502> | Reserved | | Valid | Valid |
| 3F | reg<509:504> | Matrix OUT | IN1 of LUT2_1 or Data Input of DFF1 | Valid | Valid |
| | reg<511:510> | Reserved | | Valid | Valid |
| 40 | reg<517:512> | Matrix OUT | IN0 of LUT2_2 or Clock Input of DFF2 | Valid | Valid |
| | reg<519:518> | Reserved | | Valid | Valid |
| 41 | reg<525:520> | Matrix OUT | IN1 of LUT2_2 or Data Input of DFF2 | Valid | Valid |
| | reg<527:526> | Reserved | | Valid | Valid |
| 42 | reg<533:528> | Matrix OUT | IN0 of LUT2_3 or Clock Input of PGEN | Valid | Valid |
| | reg<535:534> | Reserved | | Valid | Valid |
| 43 | reg<541:536> | Matrix OUT | IN1 of LUT2_3 or RSTB of PGEN | Valid | Valid |
| | reg<543:542> | Reserved | | Valid | Valid |
| 44 | reg<549:544> | Matrix OUT | IN0 of LUT3_0 or Clock Input of DFF3 | Valid | Valid |
| | reg<551:550> | Reserved | | Valid | Valid |
| 45 | reg<557:552> | Matrix OUT | IN1 of LUT3_0 or Data Input of DFF3 | Valid | Valid |
| | reg<559:558> | Reserved | | Valid | Valid |
| 46 | reg<565:560> | Matrix OUT | IN2 of LUT3_0 or RSTB (SETB) of DFF3 | Valid | Valid |
| | reg<567:566> | Reserved | | Valid | Valid |
| 47 | reg<573:568> | Matrix OUT | IN0 of LUT3_1 or Clock Input of DFF4 | Valid | Valid |
| | reg<575:574> | Reserved | | Valid | Valid |
| 48 | reg<581:576> | Matrix OUT | IN1 of LUT3_1 or Data Input of DFF4 | Valid | Valid |
| | reg<583:582> | Reserved | | Valid | Valid |
| 49 | reg<589:584> | Matrix OUT | IN2 of LUT3_1 or RSTB (SETB) of DFF4 | Valid | Valid |
| | reg<591:590> | Reserved | | Valid | Valid |
| 4A | reg<597:592> | Matrix OUT | IN0 of LUT3_2 or Clock Input of DFF5 | Valid | Valid |
| | reg<599:598> | Reserved | | Valid | Valid |
| 4B | reg<605:600> | Matrix OUT | IN1 of LUT3_2 or Data Input of DFF5 | Valid | Valid |
| | reg<607:606> | Reserved | | Valid | Valid |
| 4C | reg<613:608> | Matrix OUT | IN2 of LUT3_2 or RSTB (SETB) of DFF5 | Valid | Valid |
| | reg<615:614> | Reserved | | Valid | Valid |
| 4D | reg<621:616> | Matrix OUT | IN0 of LUT3_3 or Clock Input of DFF6 | Valid | Valid |
| | reg<623:622> | Reserved | | Valid | Valid |
| 4E | reg<629:624> | Matrix OUT | IN1 of LUT3_3 or Data Input of DFF6 | Valid | Valid |
| | reg<631:630> | Reserved | | Valid | Valid |
| 4F | reg<637:632> | Matrix OUT | IN2 of LUT3_3 or RSTB (SETB) of DFF6 | Valid | Valid |
| | reg<639:638> | Reserved | | Valid | Valid |

| Address | | Signal Function | Register Bit Definition | I ² C Interface | |
|---------|--------------|-----------------|---|----------------------------|-------|
| Byte | Register Bit | | | Read | Write |
| 50 | reg<645:640> | Matrix OUT | IN0 of LUT3_4 or Clock Input of DFF7 | Valid | Valid |
| | reg<647:646> | Reserved | | Valid | Valid |
| 51 | reg<653:648> | Matrix OUT | IN1 of LUT3_4 or Data Input of DFF7 | Valid | Valid |
| | reg<655:654> | Reserved | | Valid | Valid |
| 52 | reg<661:656> | Matrix OUT | IN2 of LUT3_4 or RSTB (SETB) of DFF7 | Valid | Valid |
| | reg<663:662> | Reserved | | Valid | Valid |
| 53 | reg<669:664> | Matrix OUT | IN0 of LUT3_5 or Delay2 Input (or Counter2 RST Input) | Valid | Valid |
| | reg<671:670> | Reserved | | Valid | Valid |
| 54 | reg<677:672> | Matrix OUT | IN1 of LUT3_5 or External Clock Input of Delay2 (or Counter2) | Valid | Valid |
| | reg<679:678> | Reserved | | Valid | Valid |
| 55 | reg<685:680> | Matrix OUT | IN2 of LUT3_5 | Valid | Valid |
| | reg<687:686> | Reserved | | Valid | Valid |
| 56 | reg<693:688> | Matrix OUT | IN0 of LUT3_6 or Delay3 Input (or Counter3 RST Input) | Valid | Valid |
| | reg<695:694> | Reserved | | Valid | Valid |
| 57 | reg<701:696> | Matrix OUT | IN1 of LUT3_6 or External Clock Input of Delay3 (or Counter3) | Valid | Valid |
| | reg<703:702> | Reserved | | Valid | Valid |
| 58 | reg 709:704> | Matrix OUT | IN2 of LUT3_6 | Valid | Valid |
| | reg<711:710> | Reserved | | Valid | Valid |
| 59 | reg<717:712> | Matrix OUT | IN0 of LUT3_7 or Delay4 Input (or Counter4 RST Input) | Valid | Valid |
| | reg<719:718> | Reserved | | Valid | Valid |
| 5A | reg<725:720> | Matrix OUT | IN1 of LUT3_7 or External Clock Input of Delay4 (or Counter4) | Valid | Valid |
| | reg<727:726> | Reserved | | Valid | Valid |
| 5B | reg<733:728> | Matrix OUT | IN2 of LUT3_7 | Valid | Valid |
| | reg<735:734> | Reserved | | Valid | Valid |
| 5C | reg<741:736> | Matrix OUT | IN0 of LUT3_8 or Delay5 Input (or Counter5 RST Input) | Valid | Valid |
| | reg<743:742> | Reserved | | Valid | Valid |
| 5D | reg<749:744> | Matrix OUT | IN1 of LUT3_8 or External Clock Input of Delay5 (or Counter5) | Valid | Valid |
| | reg<751:750> | Reserved | | Valid | Valid |
| 5E | reg<757:752> | Matrix OUT | IN2 of LUT3_8 | Valid | Valid |
| | reg<759:758> | Reserved | | Valid | Valid |
| 5F | reg<765:760> | Matrix OUT | IN0 of LUT3_9 or Delay6 Input (or Counter6 RST Input) | Valid | Valid |
| | reg<767:766> | Reserved | | Valid | Valid |
| 60 | reg<773:768> | Matrix OUT | IN1 of LUT3_9 or External Clock Input of Delay6 (or Counter6) | Valid | Valid |
| | reg<775:774> | Reserved | | Valid | Valid |

| Address | | Signal Function | Register Bit Definition | I ² C Interface | |
|---------|--------------|-----------------|---|----------------------------|-------|
| Byte | Register Bit | | | Read | Write |
| 61 | reg<781:776> | Matrix OUT | IN2 of LUT3_9 | Valid | Valid |
| | reg<783:782> | Reserved | | Valid | Valid |
| 62 | reg<789:784> | Matrix OUT | IN0 of LUT3_10 or Input of Pipe Delay | Valid | Valid |
| | reg<791:790> | Reserved | | Valid | Valid |
| 63 | reg<797:792> | Matrix OUT | IN1 of LUT3_10 or RSTB of Pipe Delay | Valid | Valid |
| | reg<799:798> | Reserved | | Valid | Valid |
| 64 | reg<805:800> | Matrix OUT | IN2 of LUT3_10 or Clock of Pipe Delay | Valid | Valid |
| | reg<807:806> | Reserved | | Valid | Valid |
| 65 | reg<813:808> | Matrix OUT | IN0 of LUT4_0 or Delay0 Input (or Counter0 RST/SET Input) | Valid | Valid |
| | reg<815:814> | Reserved | | Valid | Valid |
| 66 | reg<821:816> | Matrix OUT | IN1 of LUT4_0 or External Clock Input of Delay0 (or Counter0) | Valid | Valid |
| | reg<823:822> | Reserved | | Valid | Valid |
| 67 | reg<829:824> | Matrix OUT | IN2 of LUT4_0 or UP Input of FSM0 | Valid | Valid |
| | reg<831:830> | Reserved | | Valid | Valid |
| 68 | reg<837:832> | Matrix OUT | IN3 of LUT4_0 or KEEP Input of FSM0 | Valid | Valid |
| | reg<839:838> | Reserved | | Valid | Valid |
| 69 | reg<845:840> | Matrix OUT | IN0 of LUT4_1 or Delay1 Input (or Counter1 RST/SET Input) | Valid | Valid |
| | reg<847:846> | Reserved | | Valid | Valid |
| 6A | reg<853:848> | Matrix OUT | IN1 of LUT4_1 or External Clock Input of Delay1 (or Counter1) | Valid | Valid |
| | reg<855:854> | Reserved | | Valid | Valid |
| 6B | reg<861:856> | Matrix OUT | IN2 of LUT4_1 or UP Input of FSM1 | Valid | Valid |
| | reg<863:862> | Reserved | | Valid | Valid |
| 6C | reg<869:864> | Matrix OUT | IN3 of LUT4_1 or KEEP Input of FSM1 | Valid | Valid |
| | reg<871:870> | Reserved | | Valid | Valid |
| 6D | reg<877:872> | Matrix OUT | PD of crystal oscillator by reg<1268> | Valid | Valid |
| | reg<879:878> | Reserved | | Valid | Valid |
| 6E | reg<887:880> | Reserved | | Valid | Valid |
| 6F | reg<895:888> | Reserved | | Valid | Valid |
| 70 | reg<903:896> | Reserved | | Valid | Valid |
| 71 | reg<911:904> | Reserved | | Valid | Valid |
| 72 | reg<919:912> | Reserved | | Valid | Valid |
| 73 | reg<927:920> | Reserved | | Valid | Valid |
| 74 | reg<935:928> | Reserved | | Valid | Valid |
| 75 | reg<943:936> | Reserved | | Valid | Valid |
| 76 | reg<951:944> | Reserved | | Valid | Valid |
| 77 | reg<959:952> | Reserved | | Valid | Valid |
| 78 | reg<967:960> | Reserved | | Valid | Valid |
| 79 | reg<975:968> | Reserved | | Valid | Valid |
| 7A | reg<983:976> | Reserved | | Valid | Valid |
| 7B | reg<991:984> | Reserved | | Valid | Valid |

| Address | | Signal Function | Register Bit Definition | I ² C Interface | |
|-----------------|----------------|--|--|----------------------------|-------|
| Byte | Register Bit | | | Read | Write |
| 7C | reg<999:992> | Reserved | | Valid | Valid |
| 7D | reg<1007:1000> | Reserved | | Valid | Valid |
| 7E | reg<1015:1008> | Reserved | | Valid | Valid |
| 7F | reg<1023:1016> | Reserved | | Valid | Valid |
| PIN 2 | | | | | |
| 80 | reg<1024> | Reserved | | Valid | Valid |
| | reg<1025> | Reserved | | Valid | Valid |
| | reg<1027:1026> | Reserved | | Valid | Valid |
| | reg<1029:1028> | PIN2 Pull Down Resistor Value Selection | 00: Floating 01: 10 K 10: 100 K 11: 1 M | Valid | Valid |
| | reg<1031:1030> | PIN2 Mode Control | 00: Digital Input without Schmitt Trigger 01: Digital Input with Schmitt Trigger 10: Low Voltage Digital Input 11: Reserved | Valid | Valid |
| Reserved | | | | | |
| 81 | reg<1032> | Reserved | | | |
| | reg<1033> | Reserved | | | |
| | reg<1035:1034> | Reserved | | | |
| | reg<1037:1036> | Reserved | | | |
| | reg<1039:1038> | Reserved | | | |
| PIN 3 | | | | | |
| 82 | reg<1040> | Reserved | | Valid | Valid |
| | reg<1041> | PIN3 Driver Strength Selection | 0: 1X 1: 2X | Valid | Valid |
| | reg<1042> | PIN3 Pull Up/Down Resistor Selection | 0: Pull Down Resistor 1: Pull Up Resistor | Valid | Valid |
| | reg<1044:1043> | PIN3 Pull Up/Down Resistor Value Selection | 00: Floating 01: 10 K 10: 100 K 11: 1 M | Valid | Valid |
| | reg<1047:1045> | PIN3 Mode Control | 000: Digital Input without Schmitt Trigger 001: Digital Input with Schmitt Trigger 010: Low Voltage Digital Input 011: Reserved 100: Push Pull 101: Open Drain NMOS 110: Open Drain PMOS 111: Reserved | Valid | Valid |
| Reserved | | | | | |
| 83 | reg<1048> | Reserved | | | |
| | reg<1049> | Reserved | | | |
| | reg<1051:1050> | Reserved | | | |
| | reg<1053:1052> | Reserved | | | |
| | reg<1055:1054> | Reserved | | | |

| Address | | Signal Function | Register Bit Definition | I ² C Interface | |
|--------------|----------------|--|---|----------------------------|-------|
| Byte | Register Bit | | | Read | Write |
| PIN 4 | | | | | |
| 84 | reg<1056> | Reserved | | Valid | Valid |
| | reg<1057> | PIN4 Driver Strength Selection | 0: 1X 1: 2X | Valid | Valid |
| | reg<1058> | PIN4 Pull Up/Down Resistor Selection | 0: Pull Down Resistor 1: Pull Up Resistor | Valid | Valid |
| | reg<1060:1059> | PIN4 Pull Up/Down Resistor Value Selection | 00: Floating 01: 10 K 10: 100 K 11: 1 M | Valid | Valid |
| | reg<1063:1061> | PIN4 Mode Control | 000: Digital Input without Schmitt Trigger 001: Digital Input with Schmitt Trigger 010: Low Voltage Digital Input 011: Analog Input/Output 100: Push Pull 101: Open Drain NMOS 110: Open Drain PMOS 111: Analog Input & Open Drain | Valid | Valid |
| PIN 5 | | | | | |
| 85 | reg<1064> | Reserved | | Valid | Valid |
| | reg<1065> | PIN5 Pull Up/Down Resistor Selection | 0: Pull Down Resistor 1: Pull Up Resistor | Valid | Valid |
| | reg<1067:1066> | PIN5 Pull Up/Down Resistor Value Selection | 00: Floating 01: 10 K 10: 100 K 11: 1 M | Valid | Valid |
| | reg<1069:1068> | PIN5 Mode Control (sig_pin5_oe = 0) | 00: Digital Input without Schmitt Trigger 01: Digital Input with Schmitt Trigger 10: Low Voltage Digital Input 11: Analog Input/Output | Valid | Valid |
| | reg<1071:1070> | PIN5 Mode Control (sig_pin5_oe = 1) | 00: Push Pull 1X 01: Push Pull 2X 10: Open Drain NMOS 1X 11: Open Drain NMOS 2X | Valid | Valid |
| PIN 6 | | | | | |
| 86 | reg<1072> | Reserved | | Valid | Valid |
| | reg<1073> | IO6 Driver Strength Selection | 0: 1X 1: 2X | Valid | Valid |
| | reg<1074> | Select SCL & Virtual Input 0 or PIN6 | 0: SCL & Virtual Input 0 1: PIN6 | Valid | Valid |
| | reg<1076:1075> | PIN6 Pull Down Resistor Value Selection | 00: Floating 01: 10 K 10: 100 K 11: 1 M | Valid | Valid |
| 86 | reg<1079:1077> | PIN6 (or SCL) Mode Control | 000: Digital Input without Schmitt Trigger 001: Digital Input with Schmitt Trigger, 010: Low Voltage Digital Input 011: Reserved 100: Reserved 101: Open Drain NMOS 110: Reserved 111: Reserved | Valid | Valid |

| Address | | Signal Function | Register Bit Definition | I ² C Interface | |
|--------------|----------------|---|---|----------------------------|-------|
| Byte | Register Bit | | | Read | Write |
| PIN 7 | | | | | |
| 87 | reg<1080> | Reserved | | Valid | Valid |
| | reg<1081> | PIN7 (or SDA) Driver Strength Selection | 0: 1X (I ² C up to 400 KHz) 1: 2X (I ² C up to 1 MHz) | Valid | Valid |
| | reg<1082> | Select SDA & Virtual Input 1 or PIN7 | 0: SDA & Virtual Input 1 1: PIN7 | Valid | Valid |
| | reg<1084:1083> | PIN7 Pull Down Resistor Value Selection | 00: Floating 01: 10 K 10: 100 K 11: 1 M | Valid | Valid |
| | reg<1087:1085> | PIN7 (or SDA) Mode Control (input mode is selected by register at SDA, output mode is fixed as OD at SDA) | 000: Digital Input without Schmitt Trigger 001: Digital Input with Schmitt Trigger 010: Low Voltage Digital Input 011: Reserved 100: Reserved 101: Open Drain NMOS 110: Reserved 111: Reserved | Valid | Valid |
| PIN 8 | | | | | |
| 88 | reg<1088> | PIN8 4X Drive (4X, NMOS Open Drain) Selection | 0: 4X Drive OFF 1: 4X Drive ON (if sig_pin8_oe = '1' & PIN8 Mode Control = '1X') | Valid | Valid |
| | reg<1089> | PIN8 Pull Up/Down Resistor Selection | 0: Pull Down Resistor 1: Pull Up Resistor | Valid | Valid |
| | reg<1091:1090> | PIN8 Pull Up/Down Resistor Value Selection | 00: Floating 01: 10 K 10: 100 K 11: 1 M | Valid | Valid |
| | reg<1093:1092> | PIN8 Mode Control (sig_pin8_oe = 0) | 00: Digital Input without Schmitt Trigger 01: Digital Input with Schmitt Trigger 10: Low Voltage Digital Input 11: Analog Input/Output | Valid | Valid |
| | reg<1095:1094> | PIN8 Mode Control (sig_pin8_oe = 1) | 00: Push Pull 1X 01: Push Pull 2X 10: Open Drain NMOS 1X 11: Open Drain NMOS 2X | Valid | Valid |

| Address | | Signal Function | Register Bit Definition | I ² C Interface | |
|-----------------|----------------|--|---|----------------------------|-------|
| Byte | Register Bit | | | Read | Write |
| PIN 10 | | | | | |
| 89 | reg<1096> | PIN10 4X Drive (4X, NMOS Open Drain) Selection | 0: 4X Drive OFF (Default) 1: 4X Drive ON (if PIN10 Mode Control = '101') | Valid | Valid |
| | reg<1097> | PIN10 Driver Strength Selection | 0: 1X 1: 2X | Valid | Valid |
| | reg<1098> | PIN10 Pull Up/Down Resistor Selection | 0: Pull Down Resistor 1: Pull Up Resistor | Valid | Valid |
| | reg<1100:1099> | PIN10 Pull Up/Down Resistor Value Selection | 00: Floating 01: 10 K 10: 100 K 11: 1 M | Valid | Valid |
| | reg<1103:1101> | PIN10 Mode Control | 000: Digital Input without Schmitt Trigger 001: Digital Input with Schmitt Trigger 010: Low Voltage Digital Input 011: Analog Input/Output 100: Push Pull 101: Open Drain NMOS 110: Open Drain PMOS 111: Analog Input & Open Drain | Valid | Valid |
| Reserved | | | | | |
| 8A | reg<1104> | Reserved | | | |
| | reg<1105> | Reserved | | | |
| | reg<1107:1106> | Reserved | | | |
| | reg<1109:1108> | Reserved | | | |
| | reg<1111:1110> | Reserved | | | |
| PIN 11 | | | | | |
| 8B | reg<1112> | Reserved | | Valid | Valid |
| | reg<1113> | PIN11 Pull Up/Down Resistor Selection | 0: Pull Down Resistor 1: Pull Up Resistor | Valid | Valid |
| | reg<1115:1114> | PIN11 Pull Up/Down Resistor Value Selection | 00: Floating 01: 10 K 10: 100 K 11: 1 M | Valid | Valid |
| | reg<1117:1116> | PIN11 Mode Control (sig_pin11_oe = 0) | 00: Digital Input without Schmitt Trigger 01: Digital Input with Schmitt Trigger 10: Low Voltage Digital Input 11: Reserved | Valid | Valid |
| | reg<1119:1118> | PIN11 Mode Control (sig_pin11_oe = 1) | 00: Push Pull 1X 01: Push Pull 2X 10: Reserved 11: Reserved | Valid | Valid |
| Reserved | | | | | |
| 8C | reg<1120> | Reserved | | | |
| | reg<1121> | Reserved | | | |
| | reg<1122> | Reserved | | | |
| | reg<1124:1123> | Reserved | | | |
| | reg<1127:1125> | Reserved | | | |

| Address | | Signal Function | Register Bit Definition | I ² C Interface | |
|-----------------|----------------|---|--|----------------------------|-------|
| Byte | Register Bit | | | Read | Write |
| PIN 12 | | | | | |
| 8D | reg<1128> | Reserved | | Valid | Valid |
| | reg<1129> | PIN12 Pull Up/Down Resistor Selection | 0: Pull Down Resistor 1: Pull Up Resistor | Valid | Valid |
| | reg<1131:1130> | PIN12 Pull Up/Down Resistor Value Selection | 00: Floating 01: 10 K 10: 100 K 11: 1 M | Valid | Valid |
| | reg<1133:1132> | PIN12 Mode Control (sig_pin12_oe = 0) | 00: Digital Input without Schmitt Trigger 01: Digital Input with Schmitt Trigger 10: Low Voltage Digital Input 11: Reserved | Valid | Valid |
| | reg<1135:1134> | PIN12 Mode Control (sig_pin12_oe = 1) | 00: Push Pull 1X 01: Push Pull 2X 10: Open Drain NMOS 1X 11: Open Drain NMOS 2X | Valid | Valid |
| PIN 13 | | | | | |
| 8E | reg<1136> | X1 & X2 for crystal OSC enable | 0: Disable 1: Enable | Valid | Valid |
| | reg<1137> | PIN13 Driver Strength Selection | 0: 1X 1: 2X | Valid | Valid |
| | reg<1138> | PIN13 Pull Up/Down Resistor Selection | 0: Pull Down Resistor 1: Pull Up Resistor | Valid | Valid |
| | reg<1140:1139> | PIN13 Pull Up/Down Resistor Value Selection | 00: Floating 01: 10 K 10: 100 K 11: 1 M | Valid | Valid |
| | reg<1143:1141> | PIN13 Mode Control | 000: Digital Input without Schmitt Trigger 001: Digital Input with Schmitt Trigger 010: Low Voltage Digital Input 011: Sel for XOSC (X1) 100: Push Pull 101: Open Drain NMOS 110: Open Drain PMOS 111: Reserved | Valid | Valid |
| Reserved | | | | | |
| 8F | reg<1144> | Reserved | | | |
| | reg<1145> | Reserved | | | |
| | reg<1147:1146> | Reserved | | | |
| | reg<1149:1148> | Reserved | | | |
| | reg<1151:1150> | Reserved | | | |
| Reserved | | | | | |
| 90 | reg<1152> | Reserved | | | |
| | reg<1153> | Reserved | | | |
| | reg<1155:1154> | Reserved | | | |
| | reg<1157:1156> | Reserved | | | |
| | reg<1159:1158> | Reserved | | | |

| Address | | Signal Function | Register Bit Definition | I ² C Interface | |
|---|----------------|---|---|----------------------------|-------|
| Byte | Register Bit | | | Read | Write |
| PIN 14 | | | | | |
| 91 | reg<1160> | Reserved | | Valid | Valid |
| | reg<1161> | PIN14 Driver Strength Selection | 0: 1X 1: 2X | Valid | Valid |
| | reg<1162> | PIN14 Pull Up/Down Resistor Selection | 0: Pull Down Resistor 1: Pull Up Resistor | Valid | Valid |
| | reg<1164:1163> | PIN14 Pull Up/Down Resistor Value Selection | 00: Floating 01: 10 K 10: 100 K 11: 1 M | Valid | Valid |
| | reg<1167:1165> | PIN14 Mode Control | 000: Digital Input without Schmitt Trigger 001: Digital Input with Schmitt Trigger 010: Low Voltage Digital Input 011: Reserved 100: Push Pull 101: Open Drain NMOS 110: Open Drain PMOS 111: Reserved | Valid | Valid |
| ACMP1 | | | | | |
| 92 | reg<1168> | ACMP1 Positive Input Source Select | 0: IO8 1: ACMP0 IN+ source | Valid | Valid |
| | reg<1169> | ACMP1 Analog Buffer Enable (Max. BW 1MHz) | 0: Disable analog buffer 1: Enable analog buffer | Valid | Valid |
| | reg<1171:1170> | ACMP1 Hysteresis Enable | 00: 0 mV 01: 25 mV 10: 50 mV 11: 200 mV | Valid | Valid |
| ACMP0 | | | | | |
| 92 | reg<1172> | ACMP0 Positive Input Source Select | 0: IO4 1: V _{DD} | Valid | Valid |
| | reg<1173> | ACMP0 Analog Buffer Enable (Max. BW 1 MHz) | 0: Disable analog buffer 1: Enable analog buffer | Valid | Valid |
| | reg<1175:1174> | ACMP0 Hysteresis Enable | 00: 0 mV 01: 25 mV 10: 50 mV 11: 200 mV | Valid | Valid |
| Reserved | | | | | |
| 93 | reg<1177:1176> | Reserved | | | |
| | reg<1179:1178> | Reserved | | | |
| ACMP2 | | | | | |
| 93 | reg<1180> | Reserved | | | |
| | reg<1182:1181> | ACMP2 Hysteresis Enable | 00: 0 mV 01: 25 mV 10: 50 mV 11: 200 mV | Valid | Valid |
| ACMP1 100 uA Current Source Enable | | | | | |
| 93 | reg<1183> | ACMP1 100 uA Current Source Enable | 0: Disable 1: Enable | Valid | Valid |

| Address | | Signal Function | Register Bit Definition | I ² C Interface | |
|-------------------------------|--------------|--|--------------------------------------|----------------------------|-------|
| Byte | Register Bit | | | Read | Write |
| LUT3_x Function Select | | | | | |
| 94 | reg<1184> | LUT3_3 or DFF6 with RSTB/SETB Select | 0: LUT3_3 1: DFF6 with RSTB/SETB | Valid | Valid |
| | reg<1185> | LUT3_2 or DFF5 with RSTB/SETB Select | 0: LUT3_2 1: DFF5 with RSTB/SETB | Valid | Valid |
| | reg<1186> | LUT3_1 or DFF4 with RSTB/SETB Select | 0: LUT3_1 1: DFF4 with RSTB/SETB | Valid | Valid |
| | reg<1187> | LUT3_0 or DFF3 with RSTB/SETB Select (Two consecutive DFFs if reg<1471> = 1 for SM) | 0: LUT3_0 1: DFF3 with RSTB/SETB | Valid | Valid |
| LUT2_x Function Select | | | | | |
| 94 | reg<1188> | LUT2_3 or PGEN Select | 0: LUT2_3 1: PGEN | Valid | Valid |
| | reg<1189> | LUT2_2 or DFF2 Select | 0: LUT2_2 1: DFF2 | Valid | Valid |
| | reg<1190> | LUT2_1 or DFF1 Select | 0: LUT2_1 1: DFF1 | Valid | Valid |
| | reg<1191> | LUT2_0 or DFF0 Select | 0: LUT2_0 1: DFF0 | Valid | Valid |
| LUT4_x Function Select | | | | | |
| 95 | reg<1192> | LUT4_1 or DLY/CNT1(16bits) Select | 0: LUT4_1 1: DLY/CNT1(16bits) | Valid | Valid |
| | reg<1193> | LUT4_0 or DLY/CNT0(16bits) Select | 0: LUT4_0 1: DLY/CNT0(16bits) | Valid | Valid |
| LUT3_x Function Select | | | | | |
| 95 | reg<1194> | LUT3_9 or DLY/CNT6(8bits) Select | 0: LUT3_9 1: DLY/CNT6(8bits) | Valid | Valid |
| | reg<1195> | LUT3_8 or DLY/CNT5(8bits) Select | 0: LUT3_8 1: DLY/CNT5(8bits) | Valid | Valid |
| | reg<1196> | LUT3_7 or DLY/CNT4(8bits) Select | 0: LUT3_7 1: DLY/CNT4(8bits) | Valid | Valid |
| | reg<1197> | LUT3_6 or DLY/CNT3(8bits) Select | 0: LUT3_6 1: DLY/CNT3(8bits) | Valid | Valid |
| | reg<1198> | LUT3_5 or DLY/CNT2(8bits) Select | 0: LUT3_5 1: DLY/CNT2(8bits) | Valid | Valid |
| | reg<1199> | LUT3_4 or DFF7 with RSTB/SETB Select | 0: LUT3_4 1: DFF7 with RSTB/SETB | Valid | Valid |
| LUT2_1 / DFF1 | | | | | |
| 96 | reg<1200> | LUT2_1 <0> | | Valid | Valid |
| | reg<1201> | LUT2_1 <1> / DFF1 Initial Polarity Select | 0: Low 1: High | Valid | Valid |
| | reg<1202> | LUT2_1 <2> / DFF1 Output Select | 0: Q output 1: QB output | Valid | Valid |
| | reg<1203> | LUT2_1 <3> / DFF1 or Latch Select | 0: DFF function 1: Latch function | Valid | Valid |
| LUT2_0 / DFF0 | | | | | |
| 96 | reg<1204> | LUT2_0 <0> | | Valid | Valid |

| Address | | Signal Function | Register Bit Definition | I ² C Interface | |
|----------------------|----------------|--|--|----------------------------|-------|
| Byte | Register Bit | | | Read | Write |
| 96 | reg<1205> | LUT2_0 <1> / DFF0 Initial Polarity Select | 0: Low 1: High | Valid | Valid |
| | reg<1206> | LUT2_0 <2> / DFF0 Output Select | 0: Q output 1: QB output | Valid | Valid |
| | reg<1207> | LUT2_0 <3> / DFF0 or Latch Select | 0: DFF function 1: Latch function | Valid | Valid |
| LUT2_3 / PGEN | | | | | |
| 97 | reg<1211:1208> | LUT2_3<3:0> or PGEN 4bit counter data<3:0> | | Valid | Valid |
| LUT2_2 / DFF2 | | | | | |
| 97 | reg<1212> | LUT2_2 <0> | | Valid | Valid |
| | reg<1213> | LUT2_2 <1> / DFF2 Initial Polarity Select | 0: Low 1: High | Valid | Valid |
| | reg<1214> | LUT2_2 <2> / DFF2 Output Select | 0: Q output 1: QB output | Valid | Valid |
| | reg<1215> | LUT2_2 <3> / DFF2 or Latch Select | 0: DFF function 1: Latch function | Valid | Valid |
| LUT3_0 / DFF3 | | | | | |
| 98 | reg<1219:1216> | LUT3_0 <3:0> | | Valid | Valid |
| | reg<1220> | LUT3_0 <4> / DFF3 Initial Polarity Select | 0: Low 1: High | Valid | Valid |
| | reg<1221> | LUT3_0 <5> / DFF3 RSTB or SETB Select | 0: RSTB from Matrix Output 1: SETB from Matrix Output | Valid | Valid |
| | reg<1222> | LUT3_0 <6> / DFF3 Output Select | 0: Q output 1: QB output | Valid | Valid |
| | reg<1223> | LUT3_0 <7> / DFF3 or Latch Select | 0: DFF function 1: Latch function | Valid | Valid |
| LUT3_1 / DFF4 | | | | | |
| 99 | reg<1227:1224> | LUT3_1 <3:0> | | Valid | Valid |
| | reg<1228> | LUT3_1 <4> / DFF4 Initial Polarity Select | 0: Low 1: High | Valid | Valid |
| | reg<1229> | LUT3_1 <5> / DFF4 RSTB or SETB Select | 0: RSTB from Matrix Output 1: SETB from Matrix Output | Valid | Valid |
| | reg<1230> | LUT3_1 <6> / DFF4 Output Select | 0: Q output 1: QB output | Valid | Valid |
| | reg<1231> | LUT3_1 <7> / DFF4 or Latch Select | 0: DFF function 1: Latch function | Valid | Valid |
| LUT3_2 / DFF5 | | | | | |
| 9A | reg<1235:1232> | LUT3_2 <3:0> | | Valid | Valid |
| | reg<1236> | LUT3_2 <4> / DFF5 Initial Polarity Select | 0: Low 1: High | Valid | Valid |
| | reg<1237> | LUT3_2 <5> / DFF5 RSTB or SETB Select | 0: RSTB from Matrix Output 1: SETB from Matrix Output | Valid | Valid |
| | reg<1238> | LUT3_2 <6> / DFF5 Output Select | 0: Q output 1: QB output | Valid | Valid |
| 9A | reg<1239> | LUT3_2 <7> / DFF5 or Latch Select | 0: DFF function 1: Latch function | Valid | Valid |

| Address | | Signal Function | Register Bit Definition | I ² C Interface | |
|-----------------------------|----------------|--|--|----------------------------|-------|
| Byte | Register Bit | | | Read | Write |
| LUT3_3 / DFF6 | | | | | |
| 9B | reg<1243:1240> | LUT3_3 <3:0> | | Valid | Valid |
| | reg<1244> | LUT3_3 <4> / DFF6 Initial Polarity Select | 0: Low 1: High | Valid | Valid |
| | reg<1245> | LUT3_3 <5> / DFF6 RSTB or SETB Select | 0: RSTB from Matrix Output 1: SETB from Matrix Output | Valid | Valid |
| | reg<1246> | LUT3_3 <6> / DFF6 Output Select | 0: Q output 1: QB output | Valid | Valid |
| | reg<1247> | LUT3_3 <7> / DFF6 or Latch Select | 0: DFF function 1: Latch function | Valid | Valid |
| LUT3_4 / DFF7 | | | | | |
| 9C | reg<1251:1248> | LUT3_4 <3:0> | | Valid | Valid |
| | reg<1252> | LUT3_4 <4> / DFF7 Initial Polarity Select | 0: Low 1: High | Valid | Valid |
| | reg<1253> | LUT3_4 <5> / DFF7 RSTB or SETB Select | 0: RSTB from Matrix Output 1: SETB from Matrix Output | Valid | Valid |
| | reg<1254> | LUT3_4 <6> / DFF7 Output Select | 0: Q output 1: QB output | Valid | Valid |
| | reg<1255> | LUT3_4 <7> / DFF7 or Latch Select | 0: DFF function 1: Latch function | Valid | Valid |
| LUT3_10 / Pipe Delay | | | | | |
| 9D | reg<1259:1256> | LUT3_10 <3:0> / Pipe Delay OUT0 Select | | Valid | Valid |
| | reg<1263:1260> | LUT3_10 <7:4> / Pipe Delay OUT1 Select | | Valid | Valid |
| 9E | reg<1265:1264> | Select the Edge Mode of Programmable Delay & Edge Detector | 00: Rising Edge Detector 01: Falling Edge Detector 10: Both Edge Detector 11: Both Edge Delay | Valid | Valid |
| | reg<1267:1266> | Delay Value Select for Programmable Delay & Edge Detector (V _{DD} = 3.3 V, typical) | 00: 125 ns 01: 250 ns 10: 375 ns 11: 500 ns | Valid | Valid |
| | reg<1269:1268> | Crystal oscillator Power down enable | 00: No matrix PD 01: matrix PD for crystal oscillator 10: Reserved 11: Reserved | Valid | Valid |
| | reg<1270> | LUT3_10 or Pipe Delay Select | 0: LUT3_10 1: Pipe Delay | Valid | Valid |
| | reg<1271> | Pipe Delay OUT1 Polarity Select | 0: Non-inverted 1: Inverted | Valid | Valid |

| Address | | Signal Function | Register Bit Definition | I ² C Interface | |
|-----------------|----------------|--|--|----------------------------|-------|
| Byte | Register Bit | | | Read | Write |
| DLY/CNT2 | | | | | |
| 9F | reg<1273:1272> | DLY2 Mode Select or Asynchronous CNT2 Reset | 00: On both Falling and Rising Edges (for Delay & Counter Reset) 01: on Falling Edge only (for Delay & Counter Reset) 10: on Rising Edge only (for Delay & Counter Reset) 11: No Delay on either Falling or Rising Edges / High Level Reset | Valid | Valid |
| | reg<1276:1274> | DLY/CNT2 Clock Source Select | 000: Internal OSC clock 001: OSC/4 010: OSC/12 011: OSC/24 100: OSC/64 101: 25 MHz OSC clock 110: External Clock 111: Counter1 Overflow | Valid | Valid |
| | reg<1277> | DLY/CNT2 Output Selection if DLY/CNT2 Mode Selection is "11" | 0: Default Output 1: Edge Detector Output | Valid | Valid |
| | reg<1279:1278> | DLY/CNT2 Mode Selection | 00: Delay mode 01: One Shot 10: Freq. Detect 11: Counter mode | Valid | Valid |
| DLY/CNT3 | | | | | |
| A0 | reg<1281:1280> | DLY3 Mode Select or Asynchronous CNT3 Reset | 00: On both Falling and Rising Edges (for Delay & Counter Reset) 01: on Falling Edge only (for Delay & Counter Reset) 10: on Rising Edge only (for Delay & Counter Reset) 11: No Delay on either Falling or Rising Edges / High Level Reset | Valid | Valid |
| | reg<1284:1282> | DLY/CNT3 Clock Source Select | 000: Internal OSC clock 001: OSC/4 010: OSC/12 011: OSC/24 100: OSC/64 101: 25 MHz OSC clock 110: External Clock 111: Counter2 Overflow | Valid | Valid |
| | reg<1285> | DLY/CNT3 Output Selection if DLY/CNT3 Mode Selection is "11" | 0: Default Output 1: Edge Detector Output | Valid | Valid |
| | reg<1287:1286> | DLY/CNT3 Mode Selection | 00: Delay mode 01: One Shot 10: Freq. Detect 11: Counter mode | Valid | Valid |

| Address | | Signal Function | Register Bit Definition | I ² C Interface | |
|-----------------|----------------|--|--|----------------------------|-------|
| Byte | Register Bit | | | Read | Write |
| DLY/CNT4 | | | | | |
| A1 | reg<1289:1288> | DLY4 Mode Select or Asynchronous CNT4 Reset | 00: On both Falling and Rising Edges (for Delay & Counter Reset) 01: on Falling Edge only (for Delay & Counter Reset) 10: on Rising Edge only (for Delay & Counter Reset) 11: No Delay on either Falling or Rising Edges / High Level Reset | Valid | Valid |
| | reg<1292:1290> | DLY/CNT4 Clock Source Select | 000: Internal OSC clock 001: OSC/4 010: OSC/12 011: OSC/24 100: OSC/64 101: 25MHz OSC clock 110: External Clock 111: Counter3 Overflow | Valid | Valid |
| | reg<1293> | DLY/CNT4 Output Selection if DLY/CNT4 Mode Selection is "11" | 0: Default Output 1: Edge Detector Output | Valid | Valid |
| | reg<1295:1294> | DLY/CNT4 Mode Selection | 00: Delay mode 01: One Shot 10: Freq. Detect 11: Counter mode | Valid | Valid |
| DLY/CNT5 | | | | | |
| A2 | reg<1297:1296> | DLY5 Mode Select or Asynchronous CNT5 Reset | 00: On both Falling and Rising Edges (for Delay & Counter Reset) 01: on Falling Edge only (for Delay & Counter Reset) 10: on Rising Edge only (for Delay & Counter Reset) 11: No Delay on either Falling or Rising Edges / High Level Reset | Valid | Valid |
| | reg<1300:1298> | DLY/CNT5 Clock Source Select | 000: Internal OSC clock 001: OSC/4 010: OSC/12 011: OSC/24 100: OSC/64 101: 25MHz OSC clock 110: External Clock 111: Counter4 Overflow | Valid | Valid |
| | reg<1301> | DLY/CNT5 Output Selection if DLY/CNT5 Mode Selection is "11" | 0: Default Output 1: Edge Detector Output | Valid | Valid |
| | reg<1303:1302> | DLY/CNT5 Mode Selection | 00: Delay mode 01: One Shot 10: Freq. Detect 11: Counter mode | Valid | Valid |

| Address | | Signal Function | Register Bit Definition | I ² C Interface | |
|-----------------|----------------|---|---|----------------------------|-------|
| Byte | Register Bit | | | Read | Write |
| DLY/CNT6 | | | | | |
| A3 | reg<1305:1304> | DLY6 Mode Select or Asynchronous CNT6 Reset | 00: On both Falling and Rising Edges (for Delay & Counter Reset) 01: on Falling Edge only (for Delay & Counter Reset) 10: on Rising Edge only (for Delay & Counter Reset) 11: No Delay on either Falling or Rising Edges / High Level Reset | Valid | Valid |
| | reg<1308:1306> | DLY/CNT6 Clock Source Select | 000: Internal OSC clock 001: OSC/4 010: OSC/12, 011: OSC/24 100: OSC/64 101: 25MHz OSC clock 110: External Clock 111: Counter5 Overflow | Valid | Valid |
| | reg<1309> | DLY/CNT6 Output Selection if DLY/CNT6 Mode Selection is "11" | 0: Default Output 1: Edge Detector Output | Valid | Valid |
| | reg<1311:1310> | DLY/CNT6 Mode Selection | 00: Delay mode 01: One Shot 10: Freq. Detect 11: Counter mode | Valid | Valid |
| DLY/CNT0 | | | | | |
| A4 | reg<1313:1312> | DLY0 Mode Select or Asynchronous CNT0 Reset (16bits) | 00: On both Falling and Rising Edges (for Delay & Counter Reset) 01: on Falling Edge only (for Delay & Counter Reset) 10: on Rising Edge only (for Delay & Counter Reset) 11: No Delay on either Falling or Rising Edges / High Level Reset or Set | Valid | Valid |
| | reg<1316:1314> | DLY/CNT0 Clock Source Select (16bits) | 000: Internal OSC clock 001: OSC/4 010: OSC/12 011: OSC/24 100: OSC/64 101: 25MHz OSC clock 110: External Clock 111: Counter6 Overflow | Valid | Valid |
| | reg<1317> | CNT0/FSM0's Q are Set to data or Reset to 0s Selection (16bits) | 0: Reset to 0s 1: Set to data (Reg<1583:1576, 1591:1584>) | Valid | Valid |
| | reg<1319:1318> | DLY/CNT0 Mode Selection (16bits) | 00: Delay mode 01: One Shot 10: Freq. Detect 11: Counter mode | Valid | Valid |

| Address | | Signal Function | Register Bit Definition | I ² C Interface | |
|---|----------------|---|---|----------------------------|-------|
| Byte | Register Bit | | | Read | Write |
| DLY/CNT1 | | | | | |
| A5 | reg<1321:1320> | DLY1 Mode Select or Asynchronous CNT1 Reset (16bits) | 00: On both Falling and Rising Edges (for Delay & Counter Reset) 01: on Falling Edge only (for Delay & Counter Reset) 10: on Rising Edge only (for Delay & Counter Reset) 11: No Delay on either Falling or Rising Edges / High Level Reset or Set | Valid | Valid |
| | reg<1324:1322> | DLY/CNT1 Clock Source Select (16bits) | 000: Internal OSC clock 001: OSC/4 010: OSC/12 011: OSC/24 100: OSC/64 101: 25MHz OSC clock 110: External Clock 111: Counter0 Overflow | Valid | Valid |
| | reg<1325> | CNT1/FSM1's Q are Set to data or Reset to 0s Selection (16bits) | 0: Reset to 0s 1: Set to data (Reg<1599:1592, 1607:1600>) | Valid | Valid |
| | reg<1327:1326> | DLY/CNT1 Mode Selection (16bits) | 00: Delay mode 01: One Shot 10: Freq. Detect 11: Counter mode | Valid | Valid |
| DLY/CNTx One-Shot / Freq. Detect Output Polarity | | | | | |
| A6 | reg<1328> | DLY/CNT0 stop & restarting enable in CNT mode when new data is loaded | 0: Disable 1: Enable | Valid | Valid |
| | reg<1329> | Select the Polarity of DLY/CNT6's One Shot / Freq. Detect Output | 0: Default Output 1: Inverted Output | Valid | Valid |
| | reg<1330> | Select the Polarity of DLY/CNT5's One Shot / Freq. Detect Output | 0: Default Output 1: Inverted Output | Valid | Valid |
| | reg<1331> | Select the Polarity of DLY/CNT4's One Shot / Freq. Detect Output | 0: Default Output 1: Inverted Output | Valid | Valid |
| | reg<1332> | Select the Polarity of DLY/CNT3's One Shot / Freq. Detect Output | 0: Default Output 1: Inverted Output | Valid | Valid |
| | reg<1333> | Select the Polarity of DLY/CNT2's One Shot / Freq. Detect Output | 0: Default Output 1: Inverted Output | Valid | Valid |
| | reg<1334> | Select the Polarity of DLY/CNT1's One Shot / Freq. Detect Output | 0: Default Output 1: Inverted Output | Valid | Valid |
| | reg<1335> | Select the Polarity of DLY/CNT0's One Shot / Freq. Detect Output | 0: Default Output 1: Inverted Output | Valid | Valid |
| Oscillator | | | | | |
| A7 | reg<1337:1336> | OSC Clock Pre-divider for 25 MHz | 00: Div1 01: Div2 10: Div4 11: Div8 | Valid | Valid |
| | reg<1338> | OSC Fast Start-Up Enable for 25 KHz/2 MHz | 0: Disable 1: Enable | Valid | Valid |
| | reg<1340:1339> | OSC Clock Pre-divider for 25 KHz/2 MHz | 00: Div1 01: Div2 10: Div4 11: Div8 | Valid | Valid |

| Address | | Signal Function | Register Bit Definition | I ² C Interface | |
|-----------------------------------|----------------|---|---|----------------------------|-------|
| Byte | Register Bit | | | Read | Write |
| A7 | reg<1341> | Force 25 MHz Oscillator ON | 0: Auto Power ON (If any CNT/DLY use 25MHz source) 1: Force Power ON | Valid | Valid |
| | reg<1342> | Oscillator (25 KHz: Ring OSC, 2M: RC-OSC) Select | 0: 25 KHz Ring OSC 1: 2 MHz RC-OSC | Valid | Valid |
| | reg<1343> | Force 25 KHz/2MHz Oscillator ON | 0: Auto Power ON (if any CNT/DLY use 25K/2MHz source) 1: Force Power ON | Valid | Valid |
| A8 | reg<1346:1344> | Internal OSC 25 KHz/2 MHz Frequency Divider Control for matrix input <28> | 000: OSC/1 001: OSC/2 010: OSC/3 011: OSC/4 100: OSC/8 101: OSC/12 110: OSC/24 111: OSC/64 | Valid | Valid |
| | reg<1349:1347> | Internal OSC 25 KHz/2 MHz Frequency Divider Control for matrix input <27> | 000: OSC/1 001: OSC/2 010: OSC/3 011: OSC/4 100: OSC/8 101: OSC/12 110: OSC/24 111: OSC/64 | Valid | Valid |
| | reg<1350> | OSC Clock 25 KHz/2 MHz to matrix input <28> enable | 0: Disable 1: Enable | Valid | Valid |
| | reg<1351> | OSC Clock 25 KHz/2 MHz to matrix input <27> enable | 0: Disable 1: Enable | Valid | Valid |
| A9 | reg<1354:1352> | ASM_reg_init<2:0> for ASM state default setup bits | | Valid | Valid |
| | reg<1355> | Reserved | Reserved | Valid | Valid |
| | reg<1356> | OSC Clock 25 MHz to matrix input <29> enable | 0: Disable 1: Enable | Valid | Valid |
| | reg<1357> | External Clock Source Select instead of 25 MHz | 0: Internal Oscillator 1: External Clock from Pin13 | Valid | Valid |
| | reg<1358> | External Clock Source Select instead of 25 KHz/2 MHz | 0: Internal Oscillator 1: External Clock from Pin14 | Valid | Valid |
| | reg<1359> | DLY/CNT1 stop & restarting enable in CNT mode when new data is loaded | 0: Disable 1: Enable | Valid | Valid |
| ASM 8-to-1 MUX's 3 selection bits | | | | | |
| AA | reg<1362:1360> | ASM_state0_dec8x1_EN1 | | Valid | Valid |
| | reg<1363> | Reserved | | Valid | Valid |
| | reg<1366:1364> | ASM_state0_dec8x1_EN0 | | Valid | Valid |
| | reg<1367> | Reserved | | Valid | Valid |
| AB | reg<1370:1368> | ASM_state1_dec8x1_EN0 | | Valid | Valid |
| | reg<1371> | Reserved | | Valid | Valid |
| | reg<1374:1372> | ASM_state0_dec8x1_EN2 | | Valid | Valid |
| | reg<1375> | Reserved | | Valid | Valid |

| Address | | Signal Function | Register Bit Definition | I ² C Interface | |
|---------|----------------|-----------------------|-------------------------|----------------------------|-------|
| Byte | Register Bit | | | Read | Write |
| AC | reg<1378:1376> | ASM_state1_dec8x1_EN2 | | Valid | Valid |
| | reg<1379> | Reserved | | Valid | Valid |
| AC | reg<1382:1380> | ASM_state1_dec8x1_EN1 | | Valid | Valid |
| | reg<1383> | Reserved | | Valid | Valid |
| AD | reg<1386:1384> | ASM_state2_dec8x1_EN1 | | Valid | Valid |
| | reg<1387> | Reserved | | Valid | Valid |
| | reg<1390:1388> | ASM_state2_dec8x1_EN0 | | Valid | Valid |
| | reg<1391> | Reserved | | Valid | Valid |
| AE | reg<1394:1392> | ASM_state3_dec8x1_EN0 | | Valid | Valid |
| | reg<1395> | Reserved | | Valid | Valid |
| | reg<1398:1396> | ASM_state2_dec8x1_EN2 | | Valid | Valid |
| | reg<1399> | Reserved | | Valid | Valid |
| AF | reg<1402:1400> | ASM_state3_dec8x1_EN2 | | Valid | Valid |
| | reg<1403> | Reserved | | Valid | Valid |
| | reg<1406:1404> | ASM_state3_dec8x1_EN1 | | Valid | Valid |
| | reg<1407> | Reserved | | Valid | Valid |
| B0 | reg<1410:1408> | ASM_state4_dec8x1_EN1 | | Valid | Valid |
| | reg<1411> | Reserved | | Valid | Valid |
| | reg<1414:1412> | ASM_state4_dec8x1_EN0 | | Valid | Valid |
| | reg<1415> | Reserved | | Valid | Valid |
| B1 | reg<1418:1416> | ASM_state5_dec8x1_EN0 | | Valid | Valid |
| | reg<1419> | Reserved | | Valid | Valid |
| | reg<1422:1420> | ASM_state4_dec8x1_EN2 | | Valid | Valid |
| | reg<1423> | Reserved | | Valid | Valid |
| B2 | reg<1426:1424> | ASM_state5_dec8x1_EN2 | | Valid | Valid |
| | reg<1427> | Reserved | | Valid | Valid |
| | reg<1430:1428> | ASM_state5_dec8x1_EN1 | | Valid | Valid |
| | reg<1431> | Reserved | | Valid | Valid |
| B3 | reg<1434:1432> | ASM_state6_dec8x1_EN1 | | Valid | Valid |
| | reg<1435> | Reserved | | Valid | Valid |
| | reg<1438:1436> | ASM_state6_dec8x1_EN0 | | Valid | Valid |
| | reg<1439> | Reserved | | Valid | Valid |
| B4 | reg<1442:1440> | ASM_state7_dec8x1_EN0 | | Valid | Valid |
| | reg<1443> | Reserved | | Valid | Valid |
| | reg<1446:1444> | ASM_state6_dec8x1_EN2 | | Valid | Valid |
| | reg<1447> | Reserved | | Valid | Valid |
| B5 | reg<1450:1448> | ASM_state7_dec8x1_EN2 | | Valid | Valid |
| | reg<1451> | Reserved | | Valid | Valid |
| | reg<1454:1452> | ASM_state7_dec8x1_EN1 | | Valid | Valid |
| | reg<1455> | Reserved | | Valid | Valid |

| Address | | Signal Function | Register Bit Definition | I ² C Interface | |
|-------------------------------|------------------------------------|--|---|----------------------------|-------|
| Byte | Register Bit | | | Read | Write |
| Filter / Edge Detector | | | | | |
| B6 | reg<1457:1456> | Select the edge mode of Edge Detector_1 | 00: Rising Edge 01: Falling Edge 10: Both Edge 11: Delay | Valid | Valid |
| | reg<1458> | Filter_1/Edge Detector_1 output Polarity Select | 0: Filter_1 output 1: Filter_1 output inverted | Valid | Valid |
| | reg<1459> | Filter_1 or Edge Detector_1 Select (Typ. 30 ns @V _{DD} = 3.3 V) | 0: Filter_1 1: Edge Detector_1 | Valid | Valid |
| | reg<1461:1460> | Select the edge mode of Edge Detector_0 | 00: Rising Edge 01: Falling Edge 10: Both Edge 11: Delay | Valid | Valid |
| | reg<1462> | Filter_0/Edge Detector_0 output Polarity Select | 0: Filter_0 output 1: Filter_0 output inverted | Valid | Valid |
| | reg<1463> | Filter_0 or Edge Detector_0 Select (Typ. 47 ns @V _{DD} = 3.3 V) | 0: Filter_0 1: Edge Detector_0 | Valid | Valid |
| VREF / Bandgap | | | | | |
| B7 | [1464] | Reserved | | Valid | Valid |
| | [1466:1465] | Bandgap OK for ACMP Output Delay Time Select, the start Time is "Resetb_core go to High" | 00 or 10 with registers [1474:1472] = 100 (WideV _{DD} range, 1.7V~5.5V): Auto-delay mode, 550 uS for V _{DD} < 2.7V & 100 uS for 2.7 V < V _{DD} 00 or 10 with registers [1474:1472] = X10: Always 100 uS delay for 2.7 V < V _{DD} 00 or 10 with registers [1474:1472] = XX1: Always 550uS delay for V _{DD} < 2.7 V, 01: Always 550us delay regardless of registers [1474:1472] & V _{DD} , 11: Always 100 us delay with 2.7V < V _{DD} regardless of registers [1474:1472] | Valid | Valid |
| | reg<1467> | Reserved | | Valid | Valid |
| | reg<1468> | Reserved | | Valid | Valid |
| | reg<1469> | Reserved | | Valid | Valid |
| | reg<1470> | Reserved | | Valid | Valid |
| reg<1471> | Two consecutive DFFs enable for SM | 0: Disable 1: Enable | | Valid | Valid |

| Address | | Signal Function | Register Bit Definition | I ² C Interface | |
|-----------------------------------|----------------|---|--|----------------------------|-------|
| Byte | Register Bit | | | Read | Write |
| B8 | reg<1474:1472> | Power divider (V _{DD} /3, V _{DD} /4) ON/OFF | 0XX: Power divider off (if there is no use of V _{DD} /3, V _{DD} /4 @ ACMP negative in) 100: Reserved X10: Reserved XX1:Reserved | Valid | Valid |
| | reg<1475> | V _{DD} Bypass Enable when device power is 1.8 V | 0: Regulator Auto ON 1: Regulator OFF (V _{DD} Bypass) | Valid | Valid |
| | reg<1476> | Force Bandgap ON | 0: Auto-Mode 1: Enable (if chip is Power Down, the Bandgap will Power Down even if it is Set to 1). | Valid | Valid |
| | reg<1477> | NVM Power Down | 0: None (Or Programming Enable) 1: Power Down (Or Programming Disable) | Valid | Valid |
| | reg<1478> | Reserved | | Valid | Valid |
| | reg<1479> | GPIO Quick Charge Enable | 0: Disable 1: Enable | Valid | Valid |
| B9 | reg<1482:1480> | Reserved | | Valid | Valid |
| | reg<1483> | Reserved | | Valid | Valid |
| | reg<1486:1484> | Reserved | | Valid | Valid |
| | reg<1487> | Reserved | | Valid | Valid |
| BA | reg<1488> | Reserved | | Valid | Valid |
| | reg<1489> | Wake time Selection in Wake Sleep Mode | 0: short wake time 1: normal wake time | Valid | Valid |
| | reg<1490> | ACMP0 Wake & Sleep function Enable | 0: Disable 1: Enable | Valid | Valid |
| | reg<1491> | ACMP1 Wake & Sleep function Enable | 0: Disable 1: Enable | Valid | Valid |
| | reg<1492> | ACMP2 Wake & Sleep function Enable | 0: Disable 1: Enable | Valid | Valid |
| | reg<1493> | Reserved | | Valid | Valid |
| | reg<1494> | Wake Sleep Output State When WS Oscillator is Power Down if DLY/CNT0 Mode Selection is "11" | 0: Low 1: High | Valid | Valid |
| | reg<1495> | Wake Sleep Ratio Control Mode Selection if DLY/CNT0 Mode Selection is "11" | 0: Default Mode 1: Wake Sleep Ratio Control Mode | Valid | Valid |
| BB | reg<1503:1496> | Reserved | | Valid | Valid |
| BC | reg<1511:1504> | Reserved | | Valid | Valid |
| BD | reg<1519:1512> | Reserved | | Valid | Valid |
| BE | reg<1527:1520> | Reserved | | Valid | Valid |
| BF | reg<1535:1528> | Reserved | | Valid | Valid |
| LUT / DLY/CNT Control Data | | | | | |
| C0 | reg<1543:1536> | LUT3_5 <7:0> or DLY/CNT2 Control Data | 1 - 255 (Delay Time = [Counter Control Data + 1] / Freq) | Valid | Valid |
| C1 | reg<1551:1544> | LUT3_6 <7:0> or DLY/CNT3 Control Data | 1 - 255 (Delay Time = [Counter Control Data + 1] / Freq) | Valid | Valid |
| C2 | reg<1559:1552> | LUT3_7 <7:0> or DLY/CNT4 Control Data | 1 - 255 (Delay Time = [Counter Control Data + 1] / Freq) | Valid | Valid |
| C3 | reg<1567:1560> | LUT3_8 <7:0> or DLY/CNT5 Control Data | 1 - 255 (Delay Time = [Counter Control Data + 1] / Freq) | Valid | Valid |

| Address | | Signal Function | Register Bit Definition | I ² C Interface | |
|--------------|----------------|---|--|----------------------------|-------|
| Byte | Register Bit | | | Read | Write |
| C4 | reg<1575:1568> | LUT3_9 <7:0> or DLY/CNT6 Control Data | 1 - 255 (Delay Time = [Counter Control Data + 1] / Freq) | Valid | Valid |
| C5 | reg<1583:1576> | LUT4_0 <15:0> or DLY/CNT0 (16bits, <15:0> = <1591:1576>) Control Data | 1 - 65535 (Delay Time = [Counter Control Data + 2] / Freq) | Valid | Valid |
| C6 | reg<1591:1584> | | | Valid | Valid |
| C7 | reg<1599:1592> | LUT4_1 <15:0> or DLY/CNT1 (16bits, <15:0> = <1607:1592>) Control Data | 1 - 65535 (Delay Time = [Counter Control Data + 2] / Freq) | Valid | Valid |
| C8 | reg<1607:1600> | | | Valid | Valid |
| C9 | reg<1615:1608> | PGEN pattern data <15:0> = <1623:1608> | | Valid | Valid |
| CA | reg<1623:1616> | | | Valid | Valid |
| ACMP0 | | | | | |
| CB | reg<1628:1624> | ACMP0-IN Voltage Select | 00000: 50 mV 00001: 100 mV 00010: 150 mV 00011: 200 mV 00100: 250 mV 00101: 300 mV 00110: 350 mV 00111: 400 mV 01000: 450 mV 01001: 500 mV 01010: 550 mV 01011: 600 mV 01100: 650 mV 01101: 700 mV 01110: 750 mV 01111: 800 mV 10000: 850 mV 10001: 900 mV 10010: 950 mV 10011: 1 V 10100: 1.05 V 10101: 1.1 V 10110: 1.15 V 10111: 1.2 V 11000: V _{DD} /3 11001: V _{DD} /4 11010: PIN10: EXT_VREF 11011: PIN5: ACMP0- 11100: PIN10: EXT_VREF/2 11101: PIN5: ACMP0-/2 | Valid | Valid |
| | reg<1630:1629> | ACMP0 Positive Input Divider | 00: 1.0X 01: 0.5X 10: 0.33X 11: 0.25X | Valid | Valid |
| | reg<1631> | ACMP0 Low Bandwidth (MAX: 1MHz) Enable | 0: OFF 1: ON | Valid | Valid |

| Address | | Signal Function | Register Bit Definition | I ² C Interface | |
|-----------------|----------------|--|--|----------------------------|-------|
| Byte | Register Bit | | | Read | Write |
| ACMP1 | | | | | |
| CC | reg<1636:1632> | ACMP1-IN Voltage Select | 00000: 50 mV 00001: 100 mV 00010: 150 mV 00011: 200 mV 00100: 250 mV 00101: 300 mV 00110: 350 mV 00111: 400 mV 01000: 450 mV 01001: 500 mV 01010: 550 mV 01011: 600 mV 01100: 650 mV 01101: 700 mV 01110: 750 mV 01111: 800 mV 10000: 850 mV 10001: 900 mV 10010: 950 mV 10011: 1 V 10100: 1.05 V 10101: 1.1 V 10110: 1.15 V 10111: 1.2 V 11000: V _{DD} /3 11001: V _{DD} /4 11010: PIN10: EXT_VREF 11011: Reserved 11100: PIN10: EXT_VREF/2 11101: Reserved | Valid | Valid |
| | reg<1638:1637> | ACMP1 Positive Input Divider | 00: 1.0X 01: 0.5X 10: 0.33X 11: 0.25X | Valid | Valid |
| | reg<1639> | ACMP1 Low Bandwidth (MAX: 1MHz) Enable | 0: OFF 1: ON | Valid | Valid |
| ACMP2 | | | | | |
| CD | reg<1644:1640> | ACMP2-IN Voltage Select | 00000: 50 mV 00001: 100 mV 00010: 150 mV 00011: 200 mV 00100: 250 mV 00101: 300 mV 00110: 350 mV 00111: 400 mV 01000: 450 mV 01001: 500 mV 01010: 550 mV 01011: 600 mV 01100: 650 mV 01101: 700 mV 01110: 750 mV 01111: 800 mV 10000: 850 mV 10001: 900 mV 10010: 950 mV 10011: 1 V 10100: 1.05 V 10101: 1.1 V 10110: 1.15 V 10111: 1.2 V 11000: V _{DD} /3 11001: V _{DD} /4 11010: PIN10: EXT_VREF 11011: Reserved 11100: PIN10: EXT_VREF/2 11101: Reserved | Valid | Valid |
| | reg<1646:1645> | ACMP2 Positive Input Divider | 00: 1.0X 01: 0.5X 10: 0.33X 11: 0.25X | Valid | Valid |
| | reg<1647> | ACMP2 Low Bandwidth (MAX: 1MHz) Enable | 0: OFF 1: ON | Valid | Valid |
| Reserved | | | | | |
| CE | reg<1652:1648> | Reserved | | | |
| | reg<1654:1653> | Reserved | | | |
| | reg<1655> | Reserved | | | |

| Address | | Signal Function | Register Bit Definition | I ² C Interface | |
|--------------|----------------|--|--|----------------------------|---------|
| Byte | Register Bit | | | Read | Write |
| Misc. | | | | | |
| CF | reg<1656> | Reserved | | Valid | Valid |
| | reg<1657> | Switch from "Matrix OUT: OSC 25MHz PD" to "Matrix OUT: OSC 25MHz Force On" | 0: OSC PD 1: OSC Force On (Matrix Output <59>) | Valid | Valid |
| | reg<1658> | Switch from "Matrix OUT: OSC 25KHz/2MHz PD" to "Matrix OUT: OSC 25KHz/2MHz Force On" | 0: OSC PD 1: OSC Force On (Matrix Output <58>) | Valid | Valid |
| | reg<1659> | Reserved | | Valid | Valid |
| CF | reg<1660> | Reserved | | Valid | Valid |
| | reg<1661> | Reserved | | Valid | Valid |
| | reg<1662> | I ² C reset bit with reloading NVM into Data register | 0: Keep existing condition 1: Reset execution | Valid | Valid |
| | reg<1663> | Reserved | | Valid | Valid |
| D0 | reg<1671:1664> | RAM 8 outputs for ASM-state0 | | Valid | Valid |
| D1 | reg<1679:1672> | RAM 8 outputs for ASM-state1 | | Valid | Valid |
| D2 | reg<1687:1680> | RAM 8 outputs for ASM-state2 | | Valid | Valid |
| D3 | reg<1695:1688> | RAM 8 outputs for ASM-state3 | | Valid | Valid |
| D4 | reg<1703:1696> | RAM 8 outputs for ASM-state4 | | Valid | Valid |
| D5 | reg<1711:1704> | RAM 8 outputs for ASM-state5 | | Valid | Valid |
| D6 | reg<1719:1712> | RAM 8 outputs for ASM-state6 | | Valid | Valid |
| D7 | reg<1727:1720> | RAM 8 outputs for ASM-state7 | | Valid | Valid |
| D8 | reg<1735:1728> | User configurable RAM / OTP Byte 0 | | Valid | Valid |
| D9 | reg<1743:1736> | User configurable RAM / OTP Byte 1 | | Valid | Valid |
| DA | reg<1751:1744> | User configurable RAM / OTP Byte 2 | | Valid | Valid |
| DB | reg<1759:1752> | User configurable RAM / OTP Byte 3 | | Valid | Valid |
| DC | reg<1767:1760> | User configurable RAM / OTP Byte 4 | | Valid | Valid |
| DD | reg<1775:1768> | User configurable RAM / OTP Byte 5 | | Valid | Valid |
| DE | reg<1783:1776> | User configurable RAM / OTP Byte 6 | | Valid | Valid |
| DF | reg<1791:1784> | User configurable RAM / OTP Byte 7 | | Valid | Valid |
| E0 | reg<1799:1792> | Reserved | | Invalid | Invalid |
| E1 | reg<1807:1800> | Reserved | | Invalid | Invalid |
| E2 | reg<1815:1808> | Reserved | | Invalid | Invalid |
| E3 | reg<1823:1816> | Reserved | | Invalid | Invalid |
| E4 | reg<1831:1824> | Reserved | | Valid | Valid |
| E5 | reg<1832> | I ² C lock for read bits <1535:0> (Bank 0/1/2) | 0: Disable (Programmed data can be read.), 1: Enable (Programmed data can't be read.) | Valid | Invalid |
| | reg<1833> | Reserved | | Valid | Invalid |
| | reg<1835:1834> | Reserved | | Valid | Invalid |
| | reg<1839:1836> | Reserved | | Valid | Invalid |
| E6 | reg<1847:1840> | 16-bit Pattern ID Byte 0 (From NVM): ID[23:16] | | Valid | Valid |
| E7 | reg<1855:1848> | Reserved | | Valid | Invalid |
| E8 | reg<1863:1856> | Reserved | | Valid | Invalid |

| Address | | Signal Function | Register Bit Definition | I ² C Interface | |
|---------------------|----------------|--|---------------------------------|----------------------------|---------|
| Byte | Register Bit | | | Read | Write |
| E9 | reg<1867:1864> | I ² C Control Code Bit [3:0] | Value for slave address | Valid | Invalid |
| | reg<1868> | Reserved | | Valid | Valid |
| | reg<1869> | Reserved | | Valid | Valid |
| | reg<1870> | I ² C lock for write all bits (Bank 0/1/2/3) | 0: writable 1: Non-writable | Valid | Valid |
| | reg<1871> | I ² C lock for write bits <1535:0> (Bank 0/1/2) | 0: writable 1: Non-writable | Valid | Invalid |
| EA | reg<1879:1872> | CNT4 Counted Value | | Valid | Invalid |
| EB | reg<1887:1880> | CNT0 (16bits) = <1895:1880> Counted Value | | Valid | Invalid |
| EC | reg<1895:1888> | | | Valid | Invalid |
| ED | reg<1903:1896> | CNT6 Counted Value | | Valid | Invalid |
| EE | reg<1911:1904> | CNT1 (16bits) = <1919:1904> Counted Value | | Valid | Invalid |
| EF | reg<1919:1912> | | | Valid | Invalid |
| Matrix Input | | | | | |
| F0 | reg<1920> | Matrix Input 0 | GND | Valid | Invalid |
| | reg<1921> | Matrix Input 1 | Pin2 Digital Input | Valid | Invalid |
| | reg<1922> | Matrix Input 2 | GND | Valid | Invalid |
| | reg<1923> | Matrix Input 3 | Pin3 Digital Input | Valid | Invalid |
| | reg<1924> | Matrix Input 4 | GND | Valid | Invalid |
| | reg<1925> | Matrix Input 5 | Pin4 Digital Input | Valid | Invalid |
| | reg<1926> | Matrix Input 6 | Pin5 Digital Input | Valid | Invalid |
| | reg<1927> | Matrix Input 7 | PIN8 Digital Input | Valid | Invalid |
| F1 | reg<1928> | Matrix Input 8 | LUT2_0 / DFF0 Output | Valid | Invalid |
| | reg<1929> | Matrix Input 9 | LUT2_1 / DFF1 Output | Valid | Invalid |
| | reg<1930> | Matrix Input 10 | LUT2_2 / DFF2 Output | Valid | Invalid |
| | reg<1931> | Matrix Input 11 | LUT2_3 / PGEN Output | Valid | Invalid |
| | reg<1932> | Matrix Input 12 | LUT3_0 / DFF3 Output | Valid | Invalid |
| | reg<1933> | Matrix Input 13 | LUT3_1 / DFF4 Output | Valid | Invalid |
| | reg<1934> | Matrix Input 14 | LUT3_2 / DFF5 Output | Valid | Invalid |
| F2 | reg<1935> | Matrix Input 15 | LUT3_3 / DFF6 Output | Valid | Invalid |
| | reg<1936> | Matrix Input 16 | LUT3_4 / DFF7 Output | Valid | Invalid |
| | reg<1937> | Matrix Input 17 | LUT3_5 / CNT_DLY2(8bit) Output | Valid | Invalid |
| | reg<1938> | Matrix Input 18 | LUT3_6 / CNT_DLY3(8bit) Output | Valid | Invalid |
| | reg<1939> | Matrix Input 19 | LUT3_7 / CNT_DLY4(8bit) Output | Valid | Invalid |
| | reg<1940> | Matrix Input 20 | LUT3_8 / CNT_DLY5(8bit) Output | Valid | Invalid |
| | reg<1941> | Matrix Input 21 | LUT3_9 / CNT_DLY6(8bit) Output | Valid | Invalid |
| | reg<1942> | Matrix Input 22 | LUT4_0 / CNT_DLY0(16bit) Output | Valid | Invalid |
| | reg<1943> | Matrix Input 23 | LUT4_1 / CNT_DLY1(16bit) Output | Valid | Invalid |

| Address | | Signal Function | Register Bit Definition | I ² C Interface | |
|-----------------|----------------|-----------------|--|----------------------------|---------|
| Byte | Register Bit | | | Read | Write |
| F3 | reg<1944> | Matrix Input 24 | LUT3_10 / Pipe Delay (1st stage) Output | Valid | Invalid |
| | reg<1945> | Matrix Input 25 | Pipe Delay Output0 | Valid | Invalid |
| | reg<1946> | Matrix Input 26 | Pipe Delay Output1 | Valid | Invalid |
| | reg<1947> | Matrix Input 27 | Fixed "L" output because it is OSC clock. | Valid | Invalid |
| | reg<1948> | Matrix Input 28 | Fixed "L" output because it is OSC clock. | Valid | Invalid |
| | reg<1949> | Matrix Input 29 | Fixed "L" output because it is OSC clock. | Valid | Invalid |
| | reg<1950> | Matrix Input 30 | Filter0 / Edge Detect0 Output | Valid | Invalid |
| | reg<1951> | Matrix Input 31 | Filter1 / Edge Detect1 Output | Valid | Invalid |
| F4 | reg<1952> | Matrix Input 32 | Virtual Input <0> | Valid | Valid |
| | reg<1953> | Matrix Input 33 | Virtual Input <1> | Valid | Valid |
| | reg<1954> | Matrix Input 34 | Virtual Input <2> | Valid | Valid |
| F4 | reg<1955> | Matrix Input 35 | Virtual Input <3> | Valid | Valid |
| | reg<1956> | Matrix Input 36 | Virtual Input <4> | Valid | Valid |
| | reg<1957> | Matrix Input 37 | Virtual Input <5> | Valid | Valid |
| | reg<1958> | Matrix Input 38 | Virtual Input <6> | Valid | Valid |
| | reg<1959> | Matrix Input 39 | Virtual Input <7> | Valid | Valid |
| F5 | reg<1960> | Matrix Input 40 | RAM_0 Output for ASM-state | Valid | Invalid |
| | reg<1961> | Matrix Input 41 | RAM_1 Output for ASM-state | Valid | Invalid |
| | reg<1962> | Matrix Input 42 | RAM_2 Output for ASM-state | Valid | Invalid |
| | reg<1963> | Matrix Input 43 | RAM_3 Output for ASM-state | Valid | Invalid |
| | reg<1964> | Matrix Input 44 | RAM_4 Output for ASM-state | Valid | Invalid |
| | reg<1965> | Matrix Input 45 | RAM_5 Output for ASM-state | Valid | Invalid |
| | reg<1966> | Matrix Input 46 | RAM_6 Output for ASM-state | Valid | Invalid |
| | reg<1967> | Matrix Input 47 | RAM_7 Output for ASM-state | Valid | Invalid |
| F6 | reg<1968> | Matrix Input 48 | Pin10 Digital Input | Valid | Invalid |
| | reg<1969> | Matrix Input 49 | GND | Valid | Invalid |
| | reg<1970> | Matrix Input 50 | Pin11 Digital Input | Valid | Invalid |
| | reg<1971> | Matrix Input 51 | GND | Valid | Invalid |
| | reg<1972> | Matrix Input 52 | Pin12 Digital Input | Valid | Invalid |
| | reg<1973> | Matrix Input 53 | Pin13 Digital Input | Valid | Invalid |
| | reg<1974> | Matrix Input 54 | GND | Valid | Invalid |
| | reg<1975> | Matrix Input 55 | GND | Valid | Invalid |
| F7 | reg<1976> | Matrix Input 56 | Pin14 Digital Input | Valid | Invalid |
| | reg<1977> | Matrix Input 57 | ACMP_0 Output | Valid | Invalid |
| | reg<1978> | Matrix Input 58 | ACMP_1 Output | Valid | Invalid |
| | reg<1979> | Matrix Input 59 | ACMP_2 Output | Valid | Invalid |
| | reg<1980> | Reserved | | Valid | Invalid |
| | reg<1981> | Matrix Input 61 | Programmable Delay with Edge Detector Output | Valid | Invalid |
| | reg<1982> | Matrix Input 62 | Resetb_core | Valid | Invalid |
| | reg<1983> | Matrix Input 63 | V _{DD} | Valid | Invalid |
| Reserved | | | | | |
| F8 | reg<1991:1984> | Reserved | | Valid | Invalid |

| Address | | Signal Function | Register Bit Definition | I ² C Interface | |
|---------|----------------|-----------------|-------------------------|----------------------------|---------|
| Byte | Register Bit | | | Read | Write |
| F9 | reg<1999:1992> | Reserved | | Valid | Invalid |
| FA | reg<2007:2000> | Reserved | | Valid | Invalid |
| FB | reg<2015:2008> | Reserved | | Valid | Valid |
| FC | reg<2023:2016> | Reserved | | Valid | Invalid |
| FD | reg<2031:2024> | Reserved | | Valid | Invalid |
| FE | reg<2039:2032> | Reserved | | Valid | Valid |
| FF | reg<2047:2040> | Reserved | | Valid | Valid |

22.0 Package Top Marking System Definition

22.1 Before February 1, 2021

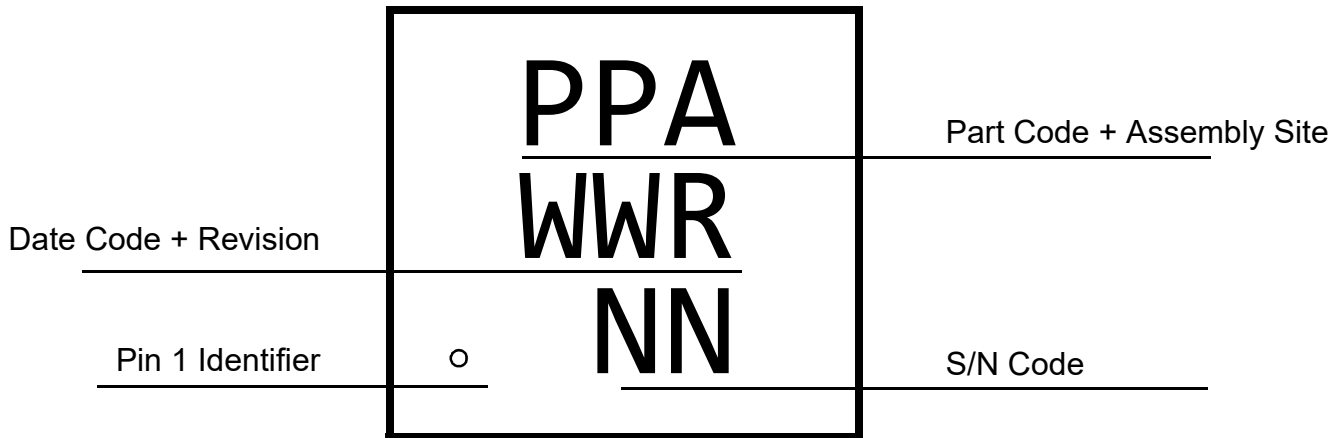

22.2 After February 1, 2021

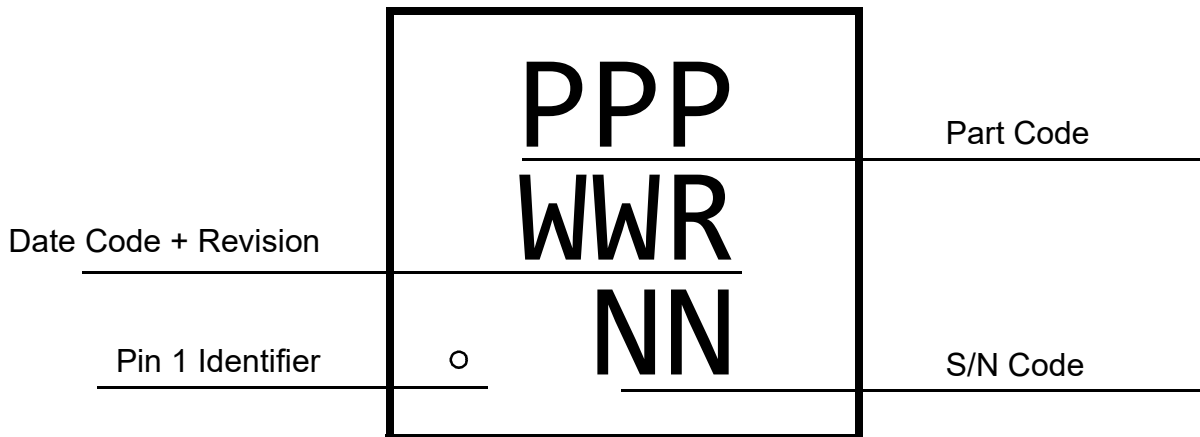

23.0 Package Drawing and Dimensions

STQFN 14L 2 x 2.2mm 0.4P COL Package
JEDEC MO-220, Variation WECE

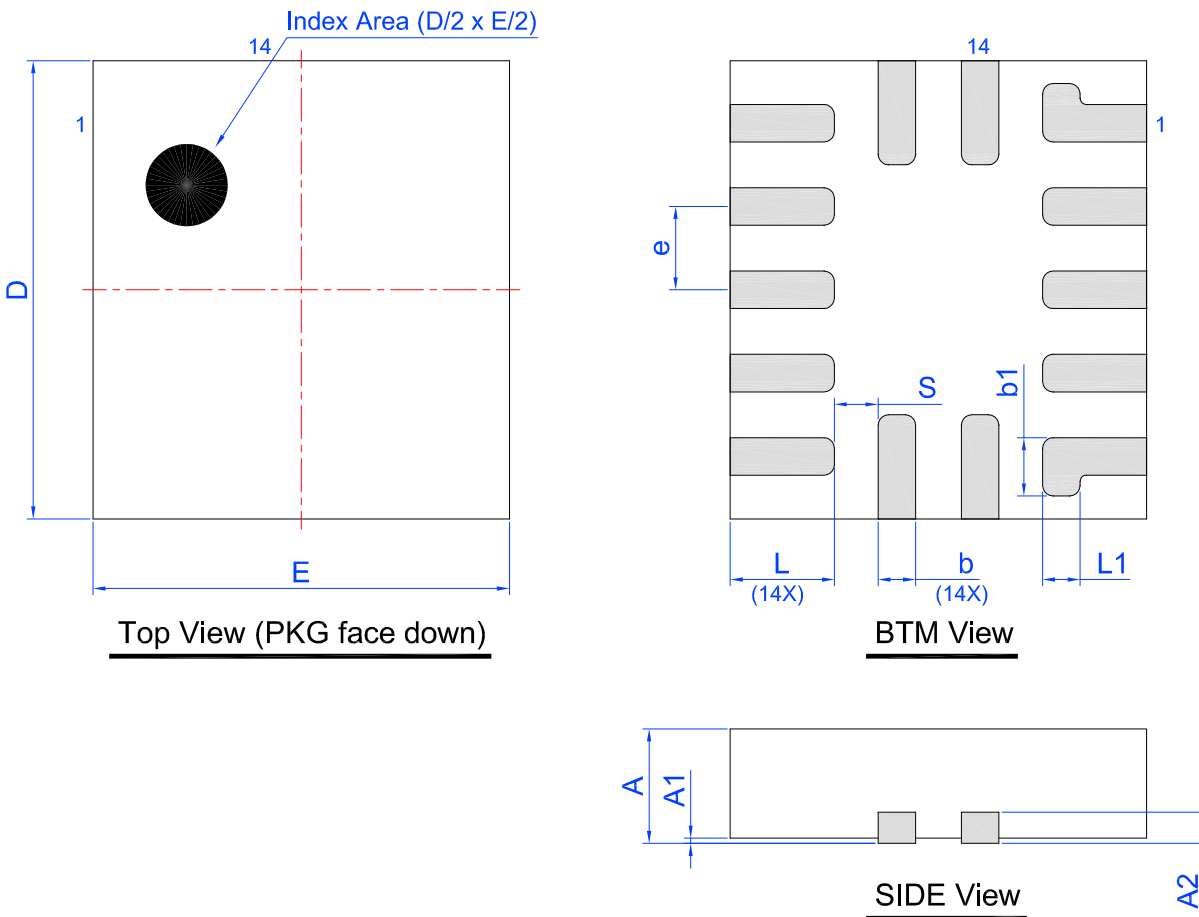

Unit: mm

| Symbol | Min | Nom. | Max | Symbol | Min | Nom. | Max |
|--------|----------|------|-------|--------|----------|------|------|
| A | 0.50 | 0.55 | 0.60 | D | 2.15 | 2.20 | 2.25 |
| A1 | 0.005 | - | 0.050 | E | 1.95 | 2.00 | 2.05 |
| A2 | 0.10 | 0.15 | 0.20 | L | 0.45 | 0.50 | 0.55 |
| b | 0.13 | 0.18 | 0.23 | S | 0.21 TYP | | |
| e | 0.40 BSC | | | b1 | 0.28 TYP | | |
| | | | | L1 | 0.18 TYP | | |

24.0 Tape and Reel Specifications

| Package Type | # of Pins | Nominal Package Size [mm] | Max Units | | Reel & Hub Size [mm] | Leader (min) | | Trailer (min) | | Tape Width [mm] | Part Pitch [mm] |
|-----------------------------|-----------|---------------------------|-----------|---------|----------------------|--------------|-------------|---------------|-------------|-----------------|-----------------|
| | | | per Reel | per Box | | Pockets | Length [mm] | Pockets | Length [mm] | | |
| STQFN 14L 2x2.2 mm 0.4P COL | 14 | 2 x 2.2 x 0.55 | 3,000 | 3,000 | 178 / 60 | 100 | 400 | 100 | 400 | 8 | 4 |

24.1 Carrier Tape Drawing and Dimensions

| Package Type | Pocket BTM Length | Pocket BTM Width | Pocket Depth | Index Hole Pitch | Pocket Pitch | Index Hole Diameter | Index Hole to Tape Edge | Index Hole to Pocket Center | Tape Width |
|-----------------------------|-------------------|------------------|--------------|------------------|--------------|---------------------|-------------------------|-----------------------------|------------|
| | A0 | B0 | K0 | P0 | P1 | D0 | E | F | W |
| STQFN 14L 2x2.2 mm 0.4P COL | 2.2 | 2.35 | 0.8 | 4 | 4 | 1.5 | 1.75 | 3.5 | 8 |

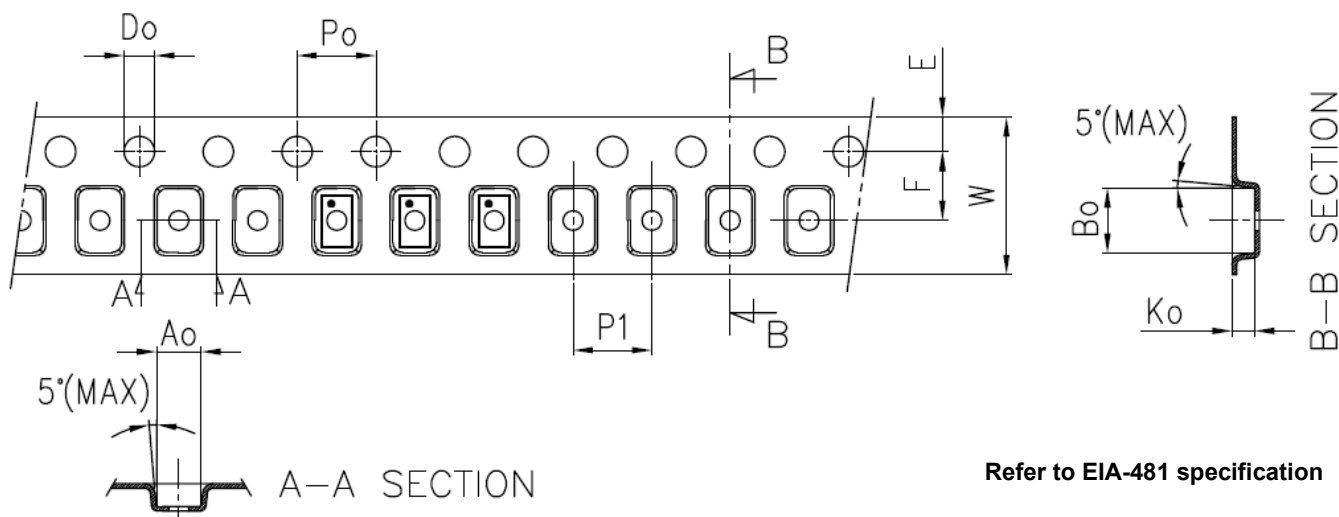

25.0 Recommended Landing Pattern

Exposed Pad
(PKG face down)

Recommended Land Pattern
(PKG face down)

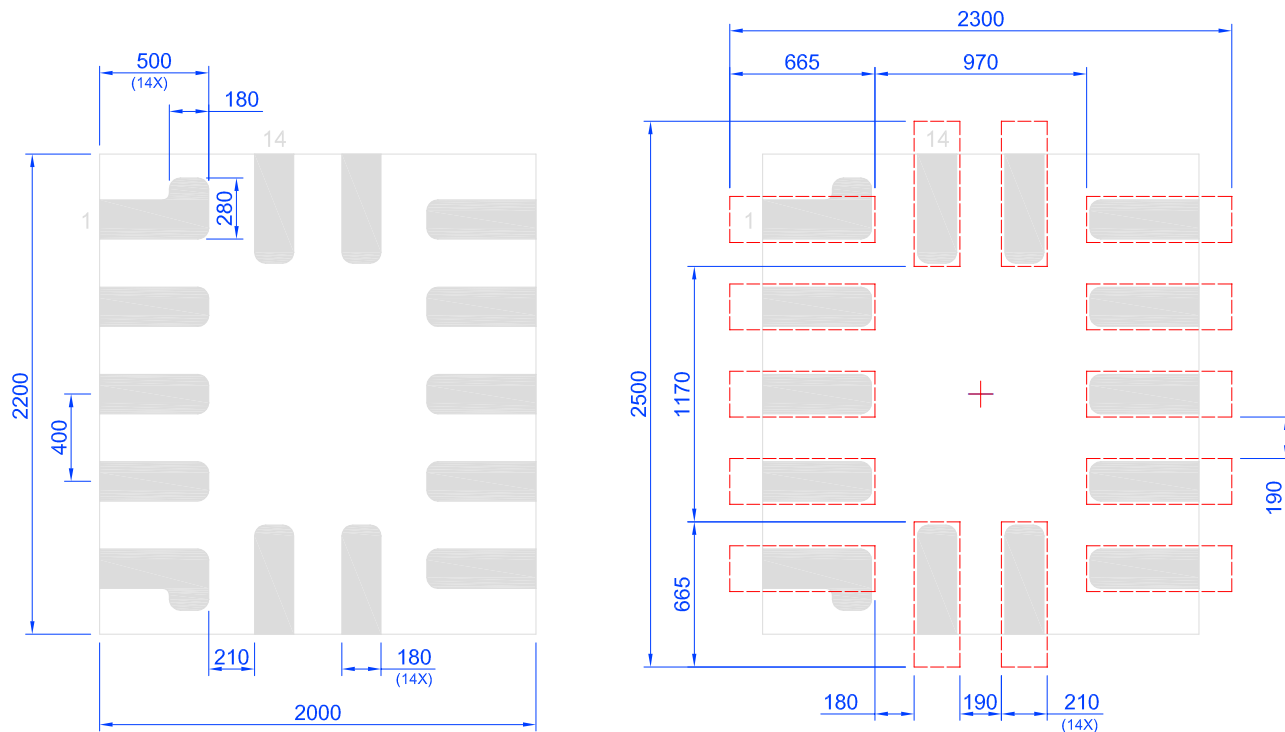

Unit:um

26.0 Recommended Reflow Soldering Profile

Please see IPC/JEDEC J-STD-020: latest revision for reflow profile based on package volume of 2.42 mm³ (nominal). More information can be found at www.jedec.org.

27.0 Revision History

| Date | Version | Change |
|------------|---------|---|
| 3/3/2023 | 1.18 | Added notes to section Ordering Information |
| 1/25/2023 | 1.17 | Corrected figure POR Sequence |
| 3/4/2022 | 1.16 | Updated R _{PUP} and R _{PDWN} in section Electrical Specifications Renesas rebranding Corrected registers [1076:1075], [1084:1083], [1087:1085] Updated Crystal Oscillator Description |
| 2/2/2021 | 1.15 | Updated section Package Top Marking System Definition |
| 8/18/2020 | 1.14 | Updated ACMP Spec Added note for CNTs Corrected Reset Command Timing figure Updated Pin Block Diagrams |
| 10/25/2019 | 1.13 | Updated disclaimer Updated register <1328> and register <1359> Corrected registers <1466:1464> Corrected 2-bit LUT2 or PGEN figure Updated registers <1047:1045>, <1143:1141>, <1167:1165>, <1636:1632> Corrected Table Read/Write Protection Options Fixed typos |
| 11/13/2018 | 1.12 | Updated to Dialog style Updated Oscillator Startup Diagram |
| 8/9/2018 | 1.11 | Updated reg<1079:1077>, reg<1087:1085> in Appendix A |
| 6/13/2018 | 1.10 | Updated I2C section Fixed typos |
| 4/17/2018 | 1.09 | Updated ASM Specifications Corrected CNT/FSM Timing Diagram Fixed typos |
| 12/26/2017 | 1.08 | Updated section RC Oscillator Updated Electrical Spec Fixed typos |
| 10/12/2017 | 1.07 | Updated Electrical Spec Fixed typos Updated I2C Specifications Updated subsection I2C Serial Reset Command Updated I2C Serial Command Register Protection Added Register Read/Write Protection subsection |
| 5/24/2017 | 1.06 | Fixed typos Updated reg<1831:1824> Updated Electrical Characteristics |
| 5/5/2017 | 1.05 | Updated Absolute Maximum Conditions Corrected table Typical Delay Estimated for Each Block at T = 25°C |
| 4/21/2017 | 1.04 | Fixed typos Updated POR section |
| 3/31/2017 | 1.03 | Fixed quality of CNT Timing Diagrams Updated Section Programmable Delay / Edge Detector Fixed typos |
| 12/20/2016 | 1.02 | Corrected Oscillator Electrical Spec Updated Silego Website & Support Fixed typos Corrected figure WS controller Added table DLY/CNTx One-Shot / Freq. Detect Output Polarity Added data to table Programmable Delay Register Settings Updated figure Deglitch Filter / Edge Detector |

| Date | Version | Change |
|------------|---------|--|
| 11/16/2016 | 1.01 | Fixed typos Corrected figure OSC1 Power On Delay Corrected table Typical Counter/Delay Offset Measurements Added subsection Difference in Counter Value for Counter, Delay, One-Shot and Frequency Detect Modes |
| 10/21/2016 | 1.00 | Production Release |

RoHS Compliance

Renesas Electronics Corporation's suppliers certify that its products are in compliance with the requirements of Directive 2011/65/EU of the European Parliament on the restriction of the use of certain hazardous substances in electrical and electronic equipment. RoHS certificates from our suppliers are available on request.