

# MIL-STD-1553 TRANSFORMERS

Low Profile, Stacked Dual THT & SMT Non-QPL Interface Transformers  
Ruggedized

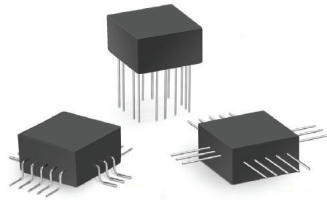

These Non-QPL interface transformers are built and tested in ISO 9001 approved facilities.

- ⊗ Through-Hole, Flat-pack and Surface Mount Configurations
- ⊗ Conform to all electrical and physical parameters of MIL-PRF-21038/27
- ⊗ Operating & Storage Temperature: -55°C to +130°C
- ⊗ Moisture Sensitivity Level:
  - ⊗ Through-Hole: 1
  - ⊗ Surface Mount: 3
- ⊗ Applicable Specifications:
  - ⊗ MIL-STD-1553B
  - ⊗ MIL-STD-202
  - ⊗ MIL-PRF-21038
  - ⊗ ISO 9001

Summary Performance Specifications	
Droop	20% MAX
Overshoot	±1V MAX
Common Mode Rejection (CMR)	45dB MIN
Frequency Range (no load)	75kHz - 1MHz
Insulation Resistance (MIN)	10K MΩ @ 250Vdc
Dielectric Withstanding Voltage	100Vrms
Prefix	SLQT (Through-Hole), SLQF (Flat-Pack), SLQG (Gull-Wing)

## Electrical Specifications

Part Number	Terminal Configuration	Ratio	RDC MAX	Impedance MIN
		(±3%)	(Ω)	(Ω)
(XXXX)1553-1	1-3:4-8 / 11-13:14-18 1-3:5-7 / 11-13:15-17	1CT:1CT 1.40CT:1CT	1-3, 11-13 = 3.5 4-8, 14-18 = 3.5	(1-3, 11-13) 4,000
(XXXX)1553-2	1-3:4-8 / 11-13:14-18 1-3:5-7 / 11-13:15-17	1.40CT:1CT 2CT:1CT	1-3, 11-13 = 3.5 4-8, 14-18 = 3.2	(1-3, 11-13) 7,200
(XXXX)1553-3	1-3:4-8 / 11-13:14-18 1-3:5-7 / 11-13:15-17	1.25CT:1CT 1.66CT:1CT	1-3, 11-13 = 3.2 4-8, 14-18 = 3.0	(1-3, 11-13) 4,000
(XXXX)1553-5	1-3:4-8 / 11-13:14-18 1-3:5-7 / 11-13:15-17	1CT:2.12CT 1CT:1.50CT	1-3, 11-13 = 1.0 4-8, 14-18 = 3.5	(4-8, 14-18) 4,000
(XXXX)1553-45	1-3:4-8 / 11-13:14-18 1-3:5-7 / 11-13:15-17	1CT:2.50CT 1CT:1.79CT	1-3, 11-13 = 1.0 4-8, 14-18 = 3.5	(4-8, 14-18) 4,000

### NOTES:

1. Replace (XXXX) from the part number in the table with the desired prefix: SLQT, SLQF, SLQG.

### Mechanicals

### Electrical Schematics

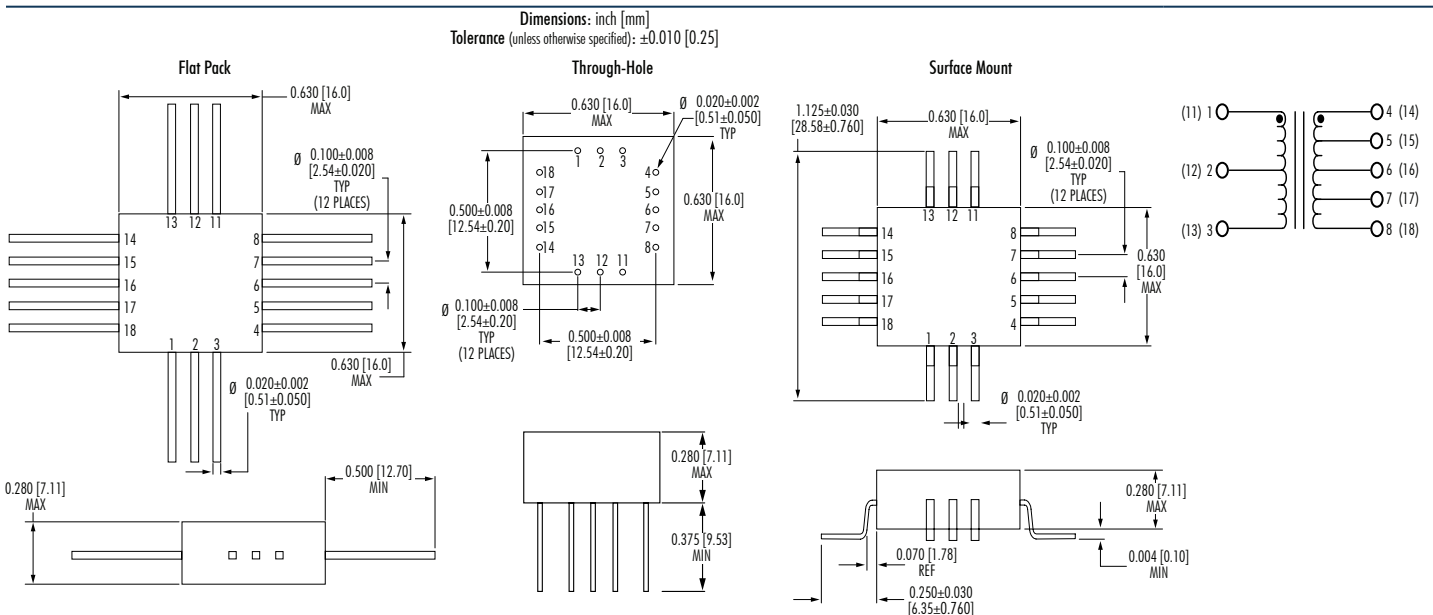

Performance warranty of products offered on this data sheet is limited to the parameters specified. Data is subject to change without notice. Other brand and product names mentioned herein may be trademarks or registered trademarks of their respective owners. © Copyright, 2020. iNRCORE, LLC. All rights reserved.

# MIL-STD-1553 TRANSFORMERS

Low Profile, Stacked Dual THT & SMT Non-QPL Interface Transformers  
Ruggedized



## MIL-PRF-21038/27 Inspection, Sampling, Testing

Table 1 - Group A Inspection					
Level "C" **		Level "M"		Level "T"	
Tests	Sampling Plan	Tests	Sampling Plan	Tests	Sampling Plan
N/A	N/A	Electrical Characteristics per MIL-PRF-21038/27	Sample per Table 3	Thermal Shock	100%
N/A	N/A	Visual & Mechanical Inspection	Sample per Table 3	Winding Continuity	100%
N/A	N/A	N/A	N/A	Electrical Characteristics per MIL-PRF-21038/27	100%
N/A	N/A	N/A	N/A	Impedance	Sample per Table 3
N/A	N/A	N/A	N/A	Visual & Mechanical Inspection	Sample per Table 3

Table 2 - Group B Inspection					
Level "C" **		Level "M"		Level "T"	
Tests	Sampling Plan	Tests	Sampling Plan	Tests	Sampling Plan
N/A	N/A	Dielectric Withstanding Voltage	Sample per Table 3	Dielectric Withstanding Voltage	Sample per Table 3
N/A	N/A	Insulation Resistance	Sample per Table 3	Insulation Resistance	Sample per Table 3

Table 3 - Sampling Plans for Group A and Group B Inspections		
Lot Size	Group A, Group II Inspections	Group B
1 to 5	All	All
6 to 13	All	5
14 to 50	13	5
51 to 90	13	7
91 to 150	13	11
151 to 280	20	13
281 to 500	29	16
501 to 1,200	34	19
1,201 to 3,200	42	23
3,201 to 10,000	50	29

\*\* Parts ordered to Level C are certified to comply with MIL-PRF-21038 Level C, however testing is performed per manufacturer's internal requirements and sampling rates.



iNRCORE, LLC  
311 Sinclair Road, Bristol, PA 19007-6812 USA  
Tel: +1.215.781.6400 Fax: +1.215.781.6430

[www.iNRCORE.com](http://www.iNRCORE.com)

M234.F (11/21)

Performance warranty of products offered on this data sheet is limited to the parameters specified. Data is subject to change without notice. Other brand and product names mentioned herein may be trademarks or registered trademarks of their respective owners. © Copyright, 2020. iNRCORE, LLC. All rights reserved.