

# Reference Manual

## BRD4502A (Rev. B00)



The EZR32LG family of Wireless MCUs deliver a high performance, low energy wireless solution integrated into a small form factor package. By combining a high performance sub-GHz RF transceiver with an energy efficient 32-bit MCU, the family provides designers the ultimate in flexibility with a family of pin-compatible devices that scale from 64/128/256 kB of flash and support Silicon Labs EZRadio or EZRadioPRO transceivers. The ultra-low power operating modes and fast wake-up times of the Silicon Labs energy friendly 32-bit MCUs, combined with the low transmit and receive power consumption of the sub-GHz radio, result in a solution optimized for battery powered applications.

To develop and/or evaluate the EZR32Leopard Gecko the EZR32LG Radio Board can be connected to the Wireless Starter Kit Mainboard to get access to display, buttons and additional features from Expansion Boards.

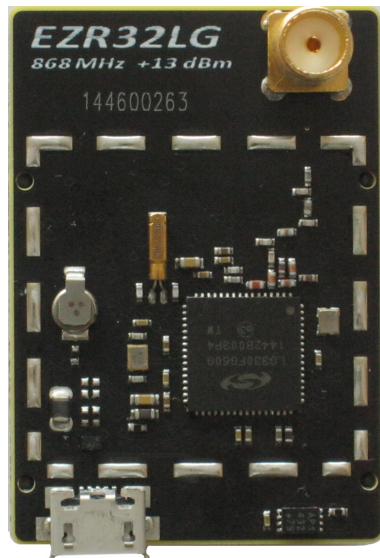

### RADIO BOARD FEATURES

- Wireless MCU: EZR32LG330F256R60G
- CPU core: ARM Cortex-M3
- Flash memory: 256 kB
- RAM: 32 kB
- Sub-GHz transceiver integrated in the Wireless MCU: EZRadioPRO
- Operation frequency: 868 MHz
- Transmit power: 13 dBm
- Single antenna connector both for transmit and receive
- Crystals for LFXO and HFXO: 32.768kHz and 48 MHz.
- Crystal for RF: 26 MHz
- Backup Power Domain Capacitor
- Full speed USB 2.0 (12 Mbps)

## Table of Contents

<b>1. Radio Board Connector Pin Associations.</b>	<b>1</b>
<b>2. EZR32LG330 System-on-Chip Summary</b>	<b>2</b>
2.1 EZR32 Wireless MCU	2
2.2 EZRadioPRO RF Transceiver	2
2.3 Communcation Between the MCU and the Radio	2
<b>3. EZR32LG Radio Board block description</b>	<b>4</b>
3.1 USB	4
3.2 RF Crystal Oscillator	4
3.3 LF Crystal Oscillator (LFXO)	4
3.4 HF Crystal Oscillator (HFXO).	4
3.5 Backup Power Domain Capacitor	4
3.6 RF Matching Network	5
3.7 SMA connector	5
3.8 Radio Board Connectors	5
<b>4. RF section</b>	<b>6</b>
4.1 Matching network.	6
<b>5. Mechanical details</b>	<b>8</b>
<b>6. RF performance</b>	<b>9</b>
6.1 Measurement setup	9
6.2 Conducted Power Measurements	9
6.3 Radiated Power Measurements	10
<b>7. Document Revision History</b>	<b>12</b>
<b>8. Errata</b>	<b>13</b>

## 1. Radio Board Connector Pin Associations

The board-to-board connector scheme allows access to all EZR32LG GPIO pins as well as the nRESET signal. The figure below shows the pin mapping on the connector to the radio pins, and their function on the Wireless Starter Kit Mainboard. For more information on the functions of the available pin functions, we refer you to the EZR32LG330 Datasheet.

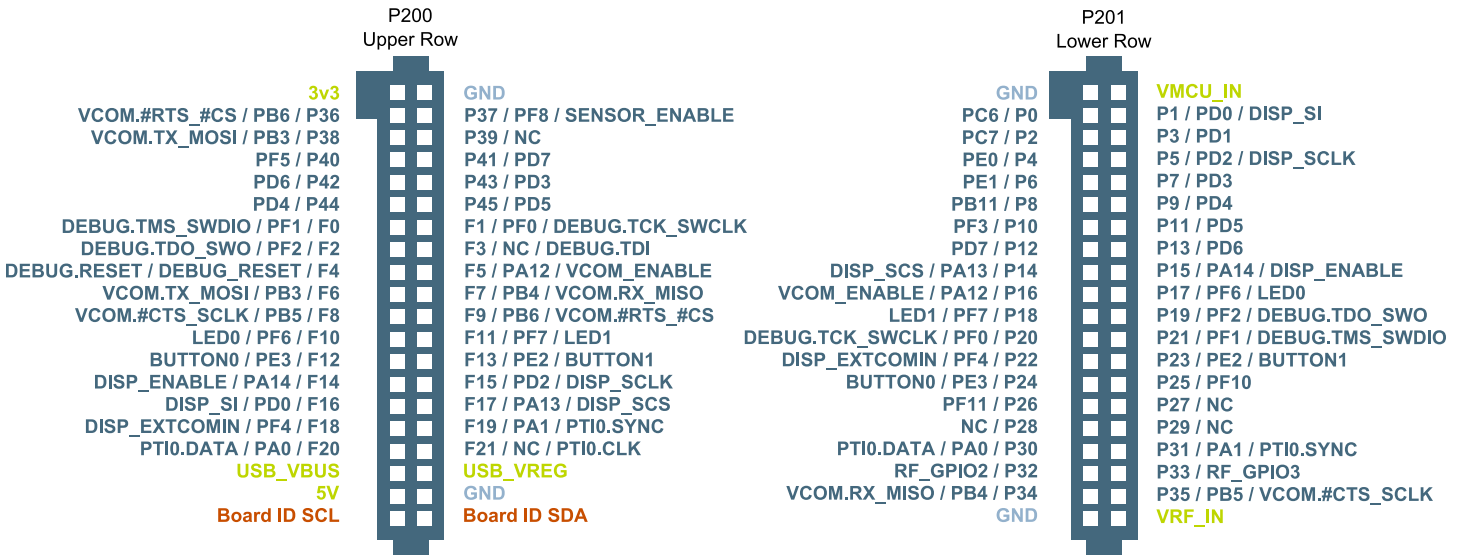

Figure 1.1. EZR32LG Radio Board Radio Board Connector pin mapping

## 2. EZR32LG330 System-on-Chip Summary

The EEZR32LG330 Wireless MCU is a single-chip solution that combines an Leopard Gecko family MCU solution with an integrated EZRadio or EZRadioPRO sub-GHz RF transceiver. These products are designed to address the specific requirements of low-power embedded systems requiring an RF bidirectional communication link.

The block diagram of the EZR32LG330 is shown in the figure below.

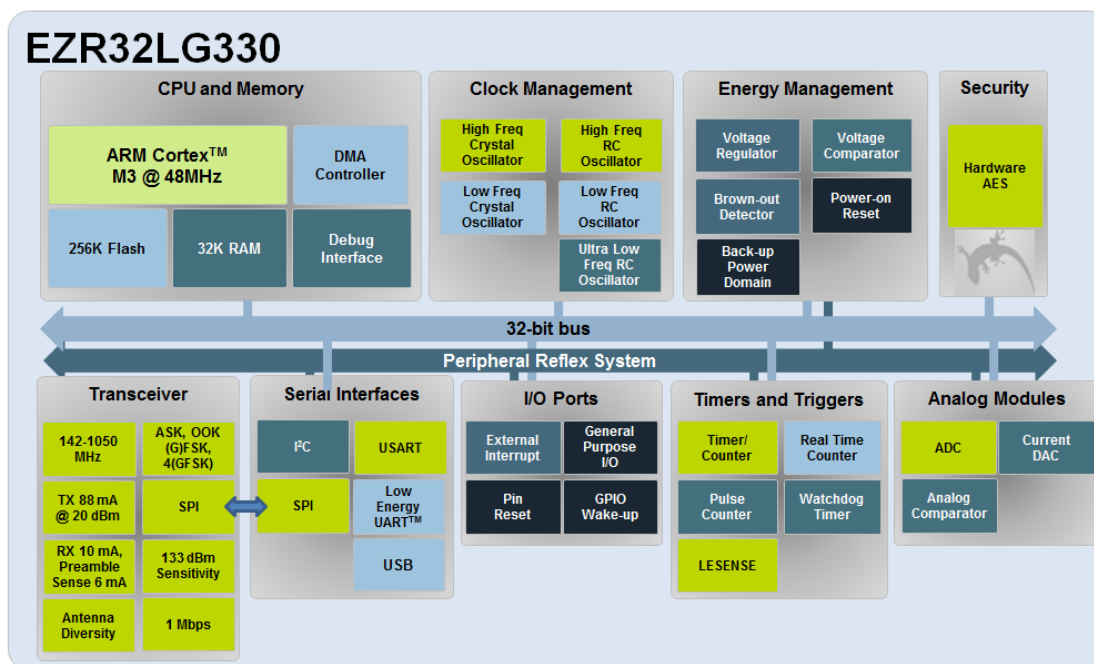

Figure 2.1. EZR32LG330 block diagram

For a complete feature set and in-depth information on the modules, the reader is referred to the EZR32LG330 Reference Manual

### 2.1 EZR32 Wireless MCU

The EZR32 Wireless MCU are the world's most energy friendly Wireless Microcontroller. With a unique combination of the powerful 32-bit ARM Cortex-M3, innovative low energy techniques, short wake-up time from energy saving modes, and a wide selection of peripherals, the EZR32 LG is well suited for any battery operated application as well as other systems requiring high performance and low-energy consumption.

### 2.2 EZRadioPRO RF Transceiver

The EZR32LG family of devices is built using high-performance, low-current EZRadio and EZRadioPRO RF transceivers covering the sub-GHz frequency bands from 142 to 1050 MHz. These devices offer outstanding sensitivity of up to  $-133$  dBm (using EZRadioPRO) while achieving extremely low active and standby current consumption. The EZR32LG devices using the transceiver offer frequency coverage in all major bands and include optimal phase noise, blocking, and selectivity performance for narrow band and licensed band applications, such as FCC Part 90 and 169 MHz wireless Mbus. The 69 dB adjacent channel selectivity with 12.5 kHz channel spacing ensures robust receive operation in harsh RF conditions, which is particularly important for narrow band operation. The active mode TX current consumption of 18 mA at +10 dBm and RX current of 10 mA coupled with extremely low standby current and fast wake times is optimized for extended battery life in the most demanding applications. The EZR32LG devices can achieve up to +27 dBm output power with built-in ramping control of a low-cost external FET. The devices can meet worldwide regulatory standards: FCC, ETSI, and ARIB. All devices are designed to be compliant with 802.15.4g and WMBus smart metering standards. The devices are highly flexible and can be programmed and configured via Simplicity Studio, available at [www.silabs.com](http://www.silabs.com).

For a complete feature set and in-depth information on the modules, the reader is referred to the Data Sheet "Si4463-61-60-C High-Performance, Low-Current Transceiver".

### 2.3 Communication Between the MCU and the Radio

Communication between the radio and MCU are done over USART, PRS and IRQ, which requires the pins to be configured in the following way:

**Table 2.1. Radio MCU Communication Configuration**

pin	Radio Assignment	pin function assignment
PE8	SDN	GPIO Output
PE9	nSEL	Bit-Banged SPI.CS (GPIO Output)
PE10	SDI	US0_TX #0
PE11	SDO	US0_RX #0
PE12	SCLK	US0_CLK #0
PE13	nIRQ	GPIO_EM4WU5 (GPIO Input with IRQ enabled)
PE14	GPIO1	PRS Input
PA15	GPIO0	PRS Input

### 3. EZR32LG Radio Board block description

The block diagram of the EZR32LG Radio Board is shown in the figure below.

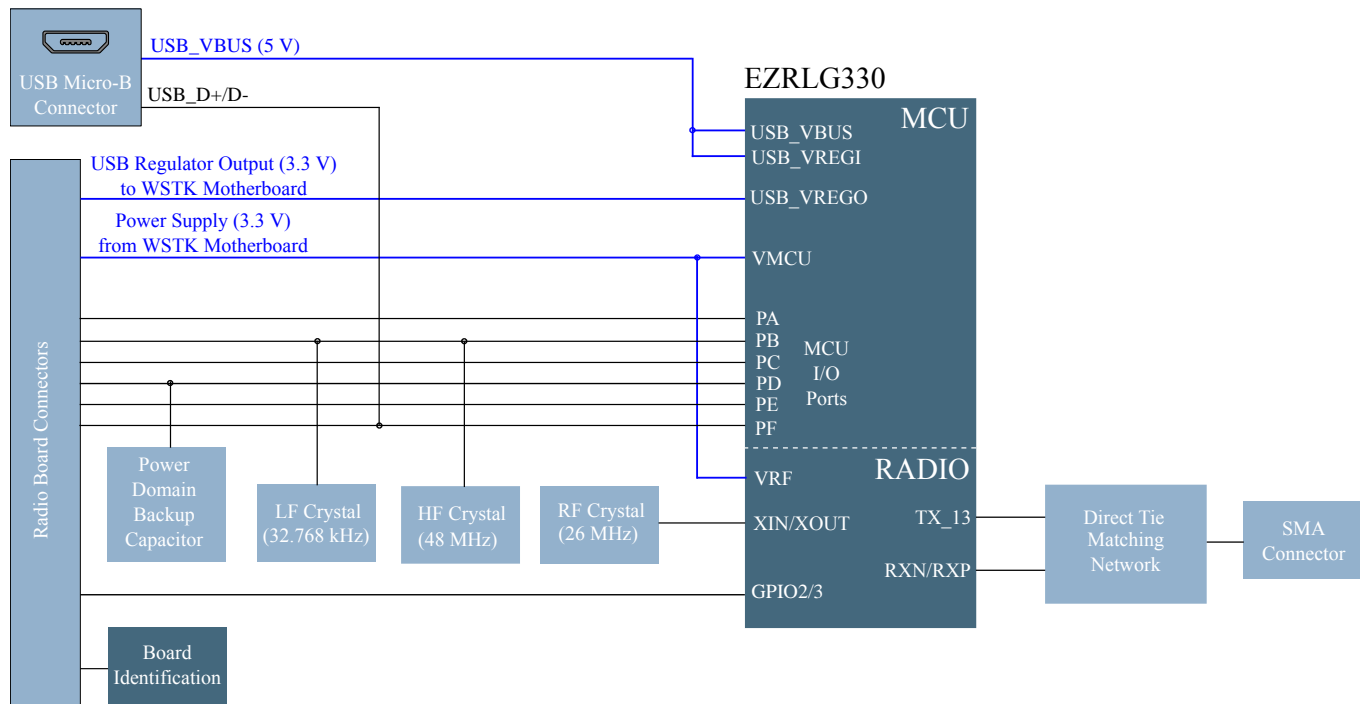

Figure 3.1. EZR32LG Radio Board block diagram

#### 3.1 USB

The EZR32LG Radio Board incorporates a micro USB connector (P/N: ZX62-B-5PA(11)). The 3.3V USB regulator output is routed back to the WSTK through the Radio Board Connector so the Radio Board can supply power to the Wireless Starter Kit Mainboard.

For additional information on EZR32LG USB, refer to the EZR32LG330 Data Sheet.

#### 3.2 RF Crystal Oscillator

The BRD4502A (Rev. B00) Radio Board has a 26 MHz crystal mounted (P/N: NX2016SA 26 MHz EXS00A-CS06236). For more details on crystal or TCXO selection for the RF part of the EZR32 devices refer to "AN785: Crystal Selection Guide for the Si4x6x RF ICs".

#### 3.3 LF Crystal Oscillator (LFXO)

The BRD4502A (Rev. B00) Radio Board has a 32.768kHz crystal mounted (P/N: MS3V-T1R, 32768Hz, 12.5pF, +/- 20ppm). For safe startup two 22 pF capacitors are also connected to the LFXTAL\_N and LFXTAL\_H pins. For details regarding the crystal configuration, the reader is referred to Application Note "AN0016: EFM32 Oscillator Design Consideration".

#### 3.4 HF Crystal Oscillator (HFXO)

The BRD4502A (Rev. B00) Radio Board has a 48 MHz crystal mounted (P/N: ABM11-48.000MHZ-D2X-T3). For safe startup two 10 pF capacitors are also connected to the HFXTAL\_N and HFXTAL\_H pins. For details regarding the crystal configuration, the reader is referred to Application Note "AN0016: EFM32 Oscillator Design Consideration".

#### 3.5 Backup Power Domain Capacitor

The BRD4502A (Rev. B00) Radio Board has a 30 mF super capacitor mounted (P/N: PAS311HR-VA6R), connected to the PD8 port of the EZR32LG.

For details regarding the Backup Power Domain, the reader is referred to the EZR32LG330 Data Sheet.

### 3.6 RF Matching Network

The BRD4502A (Rev. B00) Radio Board includes a Class E type matching network with Direct Tie TX and RX sides are connected together without an additional RF switch, to be able to use one antenna both for transmitting and receiveing. The component values were optimized for the 868 MHz band RF performace and current consumption with 13 dBm output power.

For more details on the matching network used on the BRD4502A (Rev. B00) see Chapter [4.1 Matching network](#)

### 3.7 SMA connector

To be able to perform conducted measurements or mount external antenna for radiated measurements, range tests etc., Silicon Labs added an SMA connector (P/N: 5-1814832-1) to the Radio Board. The connector allows an external 50 Ohm cable or antenna to be connected during design verification or testing.

### 3.8 Radio Board Connectors

Two dual-row, 0.05" pitch polarized connectors (P/N: SFC-120-T2-L-D-A-K-TR) make up the EZR32LG Radio Board interface to the Wireless Starter Kit Mainboard.

For more information on the pin mapping between the EZR32LG330F256R60G and the Radio Board Connector refer to Chapter [1. Radio Board Connector Pin Associations](#).

## 4. RF section

The BRD4502A (Rev. B00) Radio Board includes a Class E type TX matching network with the targeted output power of 13 dBm at 868 MHz.

The main advantage of the Class E matching types is their very high efficiency. They are proposed for applications where the current consumption is most critical, e.g., the typical total EZRadioPRO chip current with Class E type matching is ~17–19 mA at ~10 dBm and ~25 mA at ~13 dBm power levels (using the 13dBm PA output and assuming 3.3 V Vdd).

The main disadvantage of the Class E type matches is the high Vdd dependency (the power variation is proportional to the square of the Vdd change: i.e. the decrease in power can be ~6 dB in the 1.8–3.8 V range) and the inaccurate nonlinear power steps. Also their current consumption and the peak voltage on the TX pin are sensitive to the termination impedance variation, and they usually require slightly higher order filtering and thus higher bill of materials cost.

The matching network is constructed with a so-called Direct Tie configuration where the TX and RX sides are connected together without an additional RF switch, to be able to use one antenna both for transmitting and receiving. Careful design procedure was followed to ensure that the RX input circuitry does not load down the TX output path while in TX mode and that the TX output circuitry does not degrade receive performance while in RX mode.

For detailed explanation of the Class E type TX matching and the Direct Tie configuration matching procedure the reader is referred to "AN627: Si4060/Si4460/61/67 Low-Power PA Matching". For detailed description of the RX matching the reader is referred to "AN643: Si446x/Si4362 RX LNA Matching".

### 4.1 Matching network

The matching network structure used on the BRD4502A (Rev. B00) Radio Board is shown in the figure below.

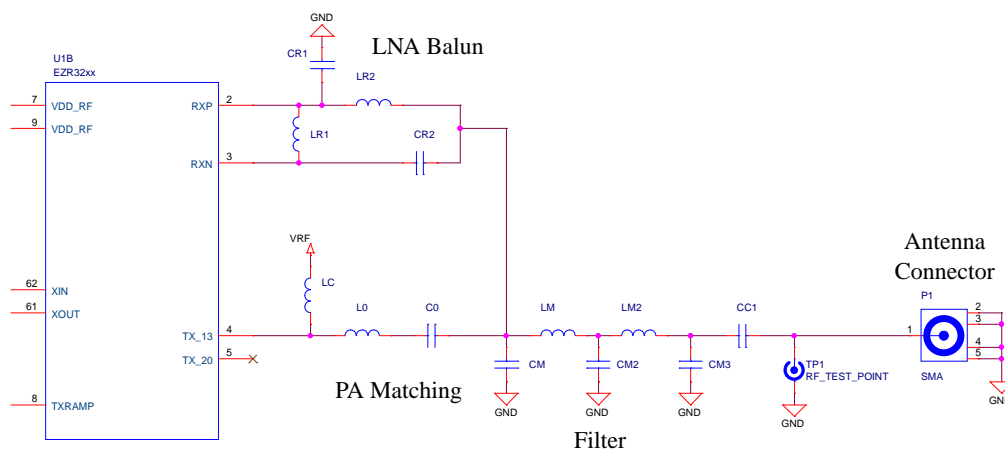

**Figure 4.1. RF section of the schematic of the EZR32 Leopard Gecko Radio Board (BRD4502A (Rev. B00))**

The matching network has a so-called Direct Tie configuration where the TX and RX sides are connected together, without an additional RF switch, to be able to use one antenna both for transmitting and receiving.

For detailed explanation of the TX matching process, see "AN627: Si4060/Si4460/61/67 Low-Power PA Matching". Due to the Direct Tie configuration of the matching, the RX matching should also taken into account during the TX matching procedure. The above Application Note contains component values and a shorter description for the RX matching as well. For detailed description of the RX matching refer to "AN643: Si446x/Si4362 RX LNA Matching".

The component values were optimized for the 868 MHz band RF performance and current consumption with 13 dBm output power. The resulting component values with part numbers are listed in the table below.



**Table 4.1. Bill of Materials for the BRD4502A (Rev. B00) RF matching network**

Component name	Value	Part Number
C0	3.6 pF	GRM1555C1H3R6C
CM	5.1 pF	GRM1555C1H5R1C
CM2	10 pF	GRM1555C1H100J
CM3	5.1 pF	GRM1555C1H5R1C
CR1	3 pF	GRM1555C1H3R0C
CR2	1 pF	GRM1555C1H1R0B
CC1	68 pF	GRM1555C1H680J
L0	19 nH	0402HP-19NXJL
LC	120 nH	0402HPH-R12XJL
LM	6.8 nH	0402HP-6N8XJL
LM2	6.8 nH	0402HP-6N8XJL
LR1	20 nH	0402HP-20NXJL
LR2	24 nH	0402HP-24NXJL

The Application Note "AN627: Si4060/Si4460/61/67 Low-Power PA Matching" contains component values for reference matching networks which were developed for the EZRadioPRO Pico Boards. For the WSTK radio boards some fine-tuning of the component values may be necessary due to different parasitic effects (bonding wire, layout etc.). For optimized RF performance the component values listed in the table above may differ from the ones listed in the referred Application Note.

For the reader's specific application and board layout the adjustment of the final matching values might be necessary. The above component values should be used as starting points and the values modified slightly to zero-in on the best filter response and impedance match to 50 ohm. To minimize the differences due to different layout parasitics Silicon Labs recommends copying the layout of the RF section of the radio board as is. If that is not possible, refer to "AN629: Si4460/61/63/64 RF ICs Layout Design Guide" for layout design recommendations.

## 5. Mechanical details

The EZR32 Leopard Gecko Radio Board (BRD4502A (Rev. B00)) is illustrated in the figures below.

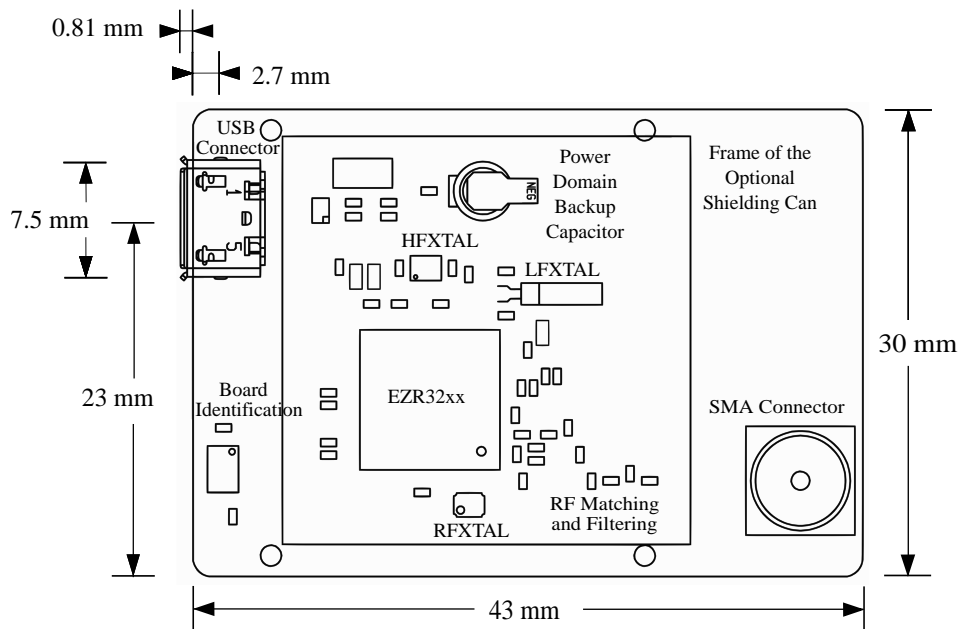

**Figure 5.1. BRD4502A (Rev. B00) top view**

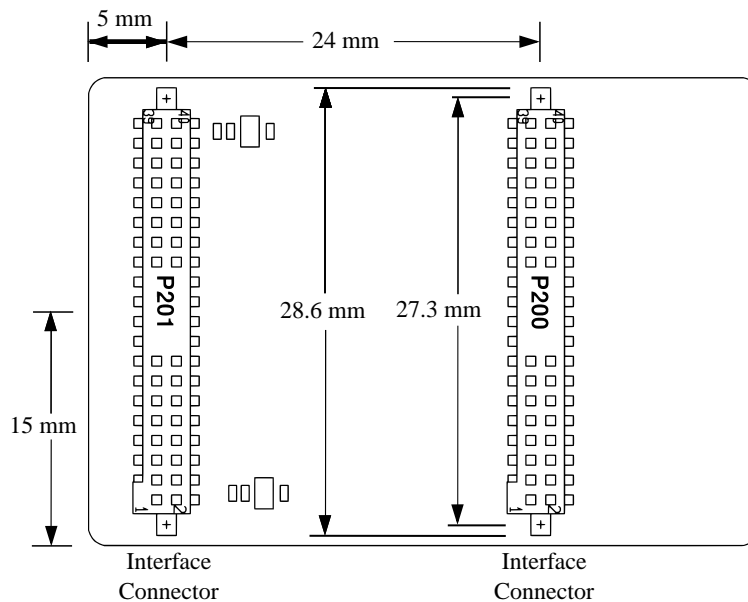

**Figure 5.2. BRD4502A (Rev. B00) bottom view**

## 6. RF performance

### 6.1 Measurement setup

The EZR32 Leopard Gecko Radio Board (BRD4502A (Rev. B00)) was attached to a Wireless Starter Kit Mainboard (BRD4001 (Rev. A02)) and its transceiver was operated in continuous carrier transmission mode. The output power of the radio was set to 13 dBm (DDAC = 3Fh).

### 6.2 Conducted Power Measurements

In case of the conducted measurements the output power was measured by connecting the EZR32LG Radio Board directly to a Spectrum Analyzer (P/N: MS2692A) through its on-board SMA connector. At 13 dBm output power and 3.3 V supply voltage the measured typical current consumption of the RF section of the board is 25.7 mA.

A typical output spectrum up to 10 GHz is shown in the figure below.

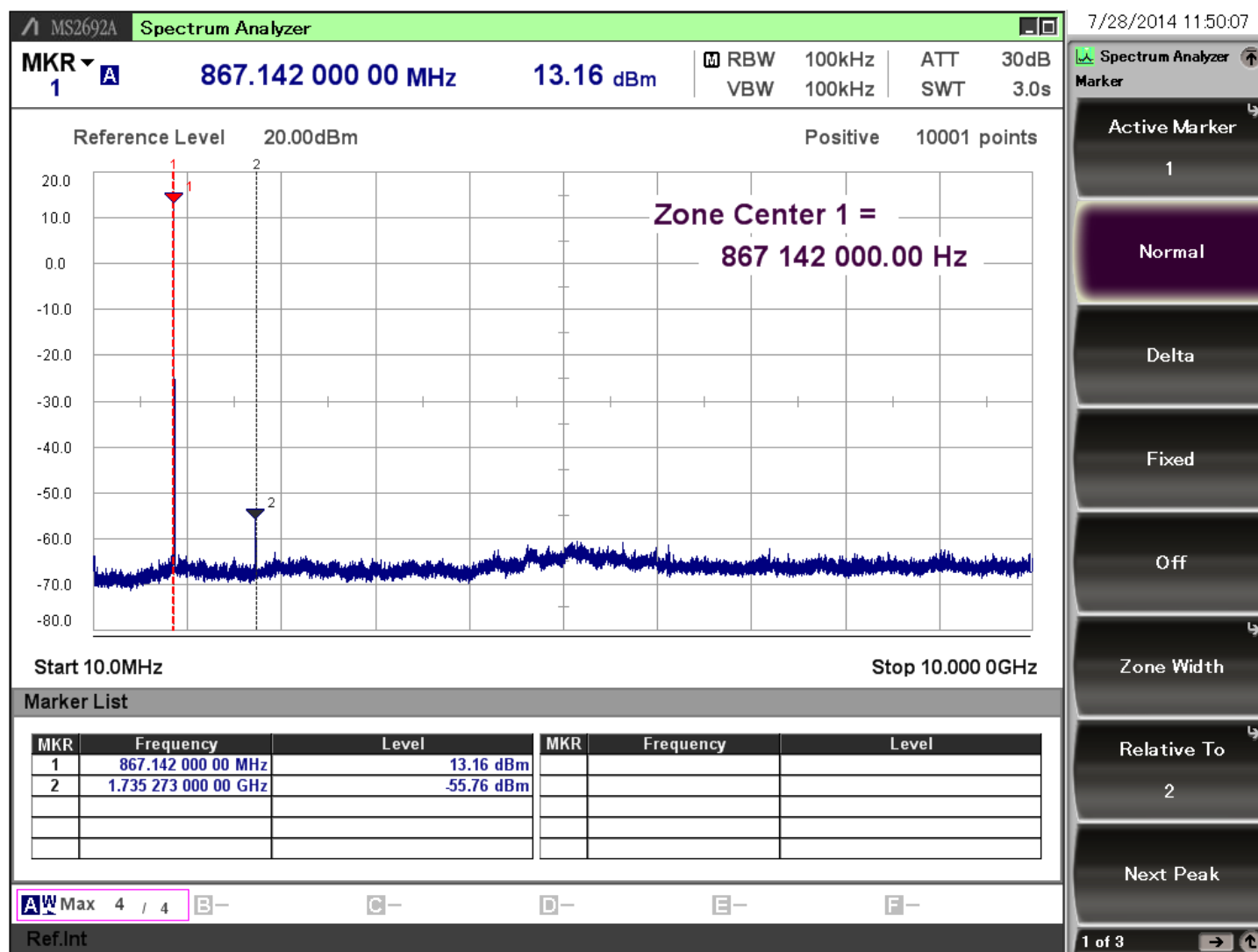

Figure 6.1. Typical output spectrum of the BRD4502A (Rev. B00) Radio Board; with DDAC=3Fh at Vdd=3.3 V

**Note:** In practice commercially available whip antennas usually have ~0-2 dB gain at the fundamental and < 0 dB gain at the harmonic frequencies so if the conducted levels are compliant with the emission limits with small margin it is likely that the margin on the harmonics radiated by an external whip antenna will be higher. Unfortunately in most cases, the PCB radiation (from traces or and/or components) is stronger so using shielding, applying larger duty cycle correction (if allowed) or reduction of the fundamental power could be necessary.

### 6.3 Radiated Power Measurements

For radiated measurements an external whip antenna (P/N: ANT-868-CW-HWR-SMA) was used. The power supply for the board were two AA batteries (3 V). The batteries were connected to the Wireless Starter Kit Mainboard through its External Power Supply connector with minimal wire length to minimize the wire radiation.

The DUT was rotated in 360 degree with horizontal and vertical reference antenna polarizations in the XY, XZ and YZ cuts. The measurement axes are as shown in the figure below.



**Figure 6.2. DUT: BRD4502A (Rev. B00) Radio Board with Wireless Starter Kit Mainboard**

The measured radiated powers are shown in the table below.

**Table 6.1. Results of the radiated power measurements**

868 MHz	Measured maximums of the radiated power in EIRP [dBm]						ETSI limit in EIRP [dBm]
	XY		XZ		YZ		
	H	V	H	V	H	V	
Fundamental	-6.9	+12.1	+9.2	-2.7	+9.0	-3.8	16.1
2nd harmonic	-56.9	53.5	-56.4	-56.8	-53.8	-56.8	-27.9
3rd harmonic	-*	-*	-*	-*	-60.0	-*	-27.9
4th harmonic	-53.0	-48.7	-48.7	-47.0	-45.7	-53.9	-27.9
5th harmonic	-*	-*	-53.4	-53.8	-51.0	-52.9	-27.9
6th harmonic	-52.7	-51.3	-47.0	-50.1	-46.7	-45.6	-27.9
7th harmonic	-51.3	-51.9	-44.6	-49.9	-46.3	-43.3	-27.9
8th harmonic	-49.1	-47.4	-41.9	-49.3	-45.0	-39.8	-27.9

868 MHz	Measured maximums of the radiated power in EIRP [dBm]						ETSI limit in EIRP [dBm]
	XY		XZ		YZ		
	H	V	H	V	H	V	
9th harmonic	-45.4	-40.8	-41.5	-44.4	-39.5	-35.6	-27.9
10th harmonic	-*	-45.5	-41.7	-*	-45.3	-37.8	-27.9

**Note:** \* Signal level is below the Spectrum Analyzer noise floor.

One may notice that the radiated harmonic levels are higher compared to the levels expected based on the conducted measurement. Investigations showed that this increase is due to the PCB radiations (components and PCB traces).

**Note:** The radiated measurement results presented in this document were recorded in an unlicensed antenna chamber. Also the radiated power levels may change depending on the actual application (PCB size, used antenna etc.) therefore the absolute levels and margins of the final application is recommended to be verified in a licensed EMC testhouse!

## 7. Document Revision History

Table 7.1. Document Revision History

Revision Number	Effective Date	Change Description
1.10	19.03.2015	Radio Board errata added.
1.00	23.02.2015	Major content update.
0.10	04.02.2015	Initial document version.

## 8. Errata

**Table 8.1. BRD4502A Radio Board Errata**

Radio Board Revision	Problem	Description
B00	USB functionality broken.	In this revision USB_VREGI and USB_VREGO pins have been swapped. This means that USB does not work on this revision of the BRD4502A radio board. If you require USB functionality, please contact support for a replacement.
	Missing MCU peripherals	Due to EZR32LG330F256R60G chip errata, UART peripherals are not available. UART functionality on USART peripherals remain unaffected.