



Features

- IEEE 802.3 Ethernet compatible
- Discrete transformers and common mode chokes for flexible PCB layout
- PoE+
- Pair with common mode choke SRF2012A-801Y for EMI reduction
- Expanded temperature range: -40 to +85 °C
- RoHS compliant*

SM453229-231N7Y - 10/100/1000 Base-T PoE+ Chip LAN Transformer

Electrical Specifications at 25 °C

Inductance
 @ 100 kHz, 0.1 V, 0 mADC
 (Pin 1-2 & 3-4 / short 6-7)
 230 μ H min.

Inductance – DC Bias
 @ 100 kHz, 0.1 V, 15 mA DC
 (Pin 1-2 & 3-4 / short 6-7)
 200 μ H min.

Turns Ratio ($\pm 3\%$)
 Pin 1-2 & 3-4 / short 6-7 1 : 1

Insertion Loss (1-100 MHz)
 -1.5 dB max.

Capacitance (Pin 3-4) 35 pF typ.

Hi-Pot (Pin 1 to 6, short 3-4)
 1500 VAC, 60 sec.

Operating Temperature -40 to +85 °C

Storage Temperature -40 to +85 °C

Packaging 2000 pcs. / reel

Electrical Schematic

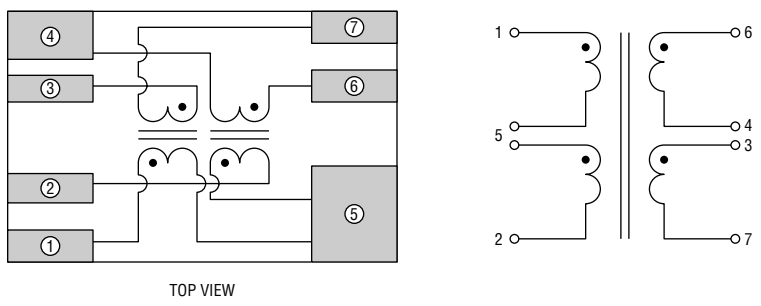

Product Dimensions

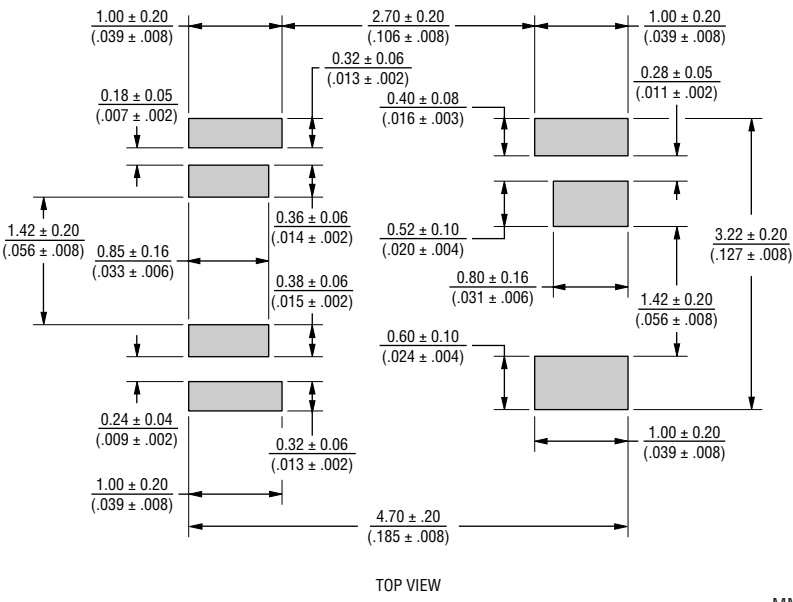
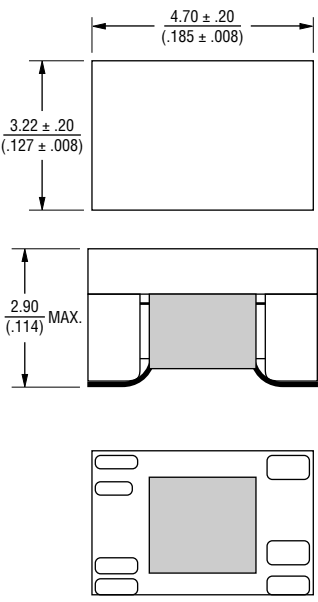

DIMENSIONS: $\frac{\text{MM}}{\text{(INCHES)}}$



WARNING Cancer and Reproductive Harm - www.P65Warnings.ca.gov

* RoHS Directive 2002/95/EC Jan. 27, 2003 including annex and RoHS Recast 2011/65/EU June 8, 2011.
 Specifications are subject to change without notice.
 Users should verify actual device performance in their specific applications.
 The products described herein and this document are subject to specific legal disclaimers as set forth on the last page of this document, and at www.bourns.com/docs/legal/disclaimer.pdf.

SM453229-231N7Y - 10/100/1000 Base-T PoE+ Chip LAN Transformer



Recommended Pad Layout

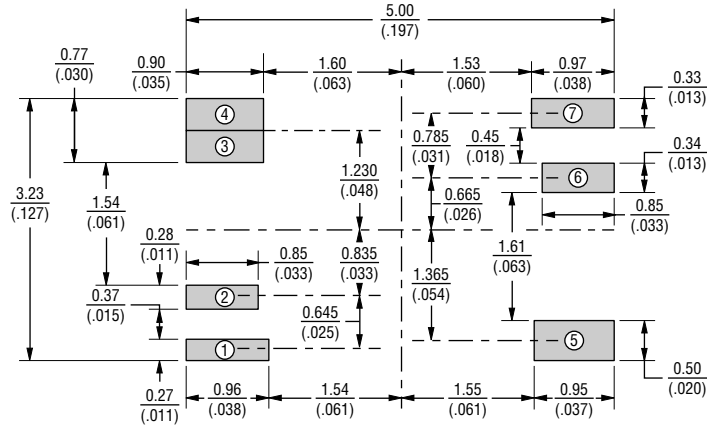

DIMENSIONS: $\frac{\text{MM}}{\text{(INCHES)}}$

Soldering Profile

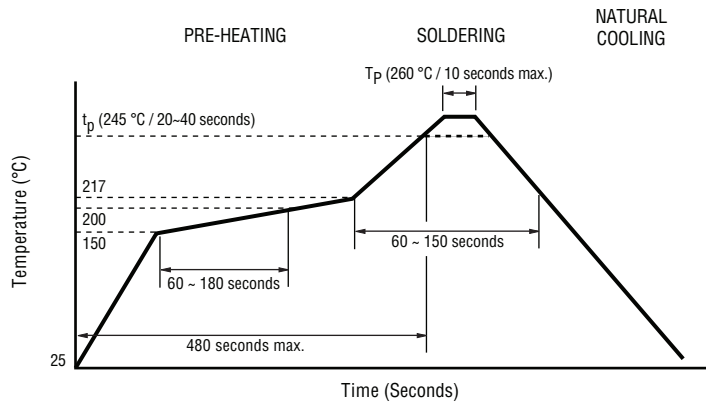

REFLOW TIMES: 3 MAX.

Specifications are subject to change without notice.

Users should verify actual device performance in their specific applications.

The products described herein and this document are subject to specific legal disclaimers as set forth on the last page of this document, and at www.bourns.com/docs/legal/disclaimer.pdf.

SM453229-231N7Y - 10/100/1000 Base-T PoE+ Chip LAN Transformer

BOURNS®

Packaging Specifications

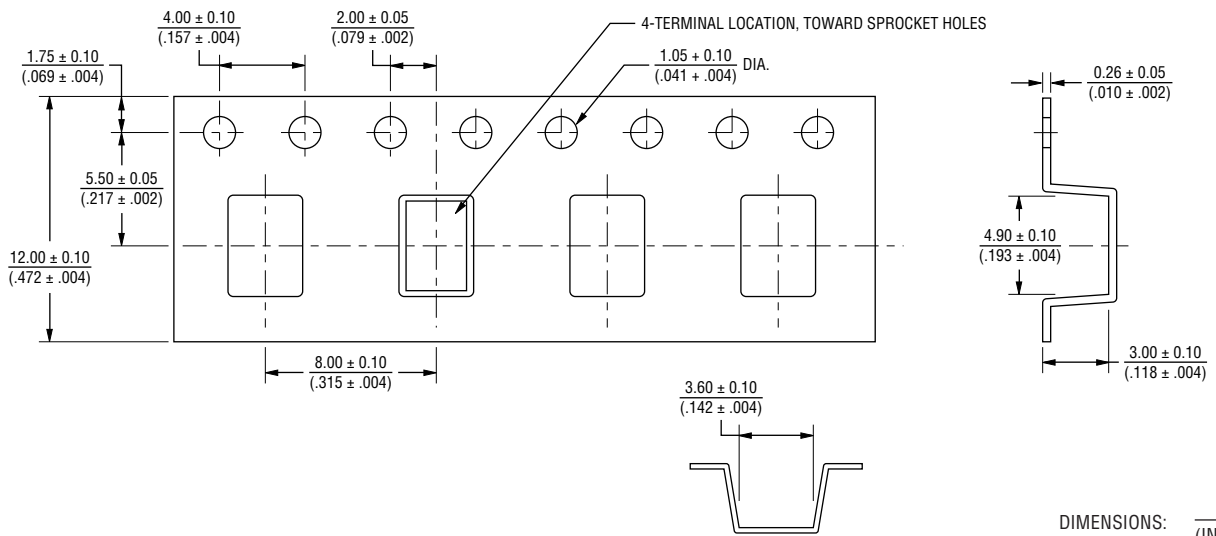
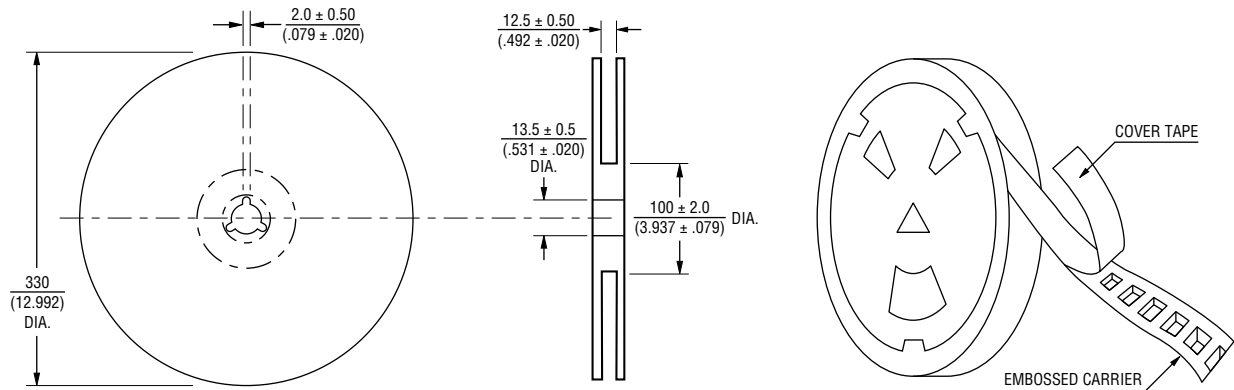

DIMENSIONS: $\frac{\text{MM}}{\text{(INCHES)}}$

BOURNS®

Asia-Pacific: Tel: +886-2 2562-4117 • Email: asiacus@bourns.com

EMEA: Tel: +36 88 885 877 • Email: eurocus@bourns.com

The Americas: Tel: +1-951 781-5500 • Email: americus@bourns.com

www.bourns.com

REV. 02/19

Specifications are subject to change without notice.

Users should verify actual device performance in their specific applications.

The products described herein and this document are subject to specific legal disclaimers as set forth on the last page of this document, and at www.bourns.com/docs/legal/disclaimer.pdf.