	<b>E480232</b>
---	----------------

**Features**

- AEC-Q101 Qualified
- Meet ISO7637-2 5a Surge Specification
- Low Leakage
- Glass Passivated Junction
- Polarity: Heatsink is Anode
- Excellent Clamping Capability
- Uni-directional Polarity
- Moisture Sensitivity Level 1
- Epoxy Meets UL 94 V-0 Flammability Rating
- Lead Free Finish/RoHS Compliant (Note1) ("P" Suffix Designates RoHS Compliant. See Ordering Information)

**Maximum Ratings**

- Operating Junction Temperature Range: -55°C to +175°C
- Storage Temperature Range: -55°C to +175°C

Peak Pulse Power Surge Current with a 10/1000µs Waveform	$I_{PPM}$	See the Table	Note 2
Peak Pulse Power Dissipation with a 10/1000µs Waveform	$P_{PPM}$	3600W	Note 2
Peak Pulse Power Dissipation with a 10/10000µs Waveform	$P_{PPM}$	2800W	Note 2
Power Dissipation On Infinite Heatsink	$P_D$	5.0W	$T_L=25^\circ C$
Peak forward surge current	$I_{FSM}$	500A	Note 3

Note: 1. High Temperature Solder Exemptions Applied, see EU Directive Annex 7a.  
 2. on-repetitive current pulse, per Fig.3 and derated above  $T_A=25^\circ C$  per Fig.2  
 3. Peak forward surge current 8.3 ms single half sine

**3600 Watt  
TVS  
10 to 43 Volts**

**DO-218AB**

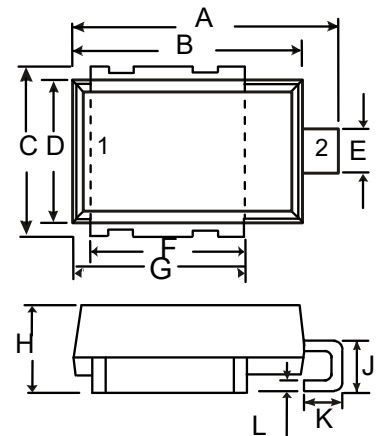

DIM	INCHES		MM		NOTE
	MIN	MAX	MIN	MAX	
A	0.590	0.630	15.00	16.00	
B	0.524	0.539	13.30	13.70	
C	0.374	0.413	9.50	10.50	
D	0.323	0.339	8.20	8.60	
E	0.091	0.114	2.30	2.90	
F	0.343	0.366	8.70	9.30	
G	0.382	0.406	9.70	10.30	
H	0.189	0.205	4.80	5.20	
J	0.098	0.138	2.50	3.50	
K	0.067	0.106	1.70	2.70	
L	0.020	0.028	0.50	0.70	

**SUGGESTED SOLDER PAD LAYOUT**



**Electrical Characteristics @ 25°C Unless Otherwise Specified**

MCC Part Number	Breakdown Voltage $V_{BR}$ @ $I_T$			Maximum Reverse Leakage $I_R$ @ $V_{RWM}$ ( $\mu A$ )	Maximum IR @ $V_{RWM}$ $T_J=175$ ( $\mu A$ )	Working Peak Reverse Voltage $V_{RWM}$ (V)	Maximum Reverse Surge Current IPP (A) <sup>(1)</sup>	Maximum Clamping Voltage $V_C$ @ $I_{PP}$ (V)
	Min (V)	Max (V)	$I_T$ (mA)					
SM5S10A	11.1	12.3	5	15	250	10	212.0	17.0
SM5S11A	12.2	13.5	5	10	150	11	198.0	18.2
SM5S12A	13.3	14.7	5	10	150	12	181.0	19.9
SM5S13A	14.4	15.9	5	10	150	13	167.0	21.5
SM5S14A	15.60	17.20	5	10	150	14	155.0	23.2
SM5S15A	16.70	18.50	5	10	150	15	148.0	24.4
SM5S16A	17.80	19.70	5	10	150	16	138.0	26.0
SM5S17A	18.90	20.90	5	10	150	17	130.0	27.6
SM5S18A	20.00	22.10	5	10	150	18	123.0	29.2
SM5S20A	22.20	24.50	5	10	150	20	111.0	32.4
SM5S22A	24.40	26.90	5	10	150	22	101.0	35.5
SM5S24A	26.70	29.50	5	10	150	24	93.0	38.9
SM5S26A	28.90	31.90	5	10	150	26	86.0	42.1
SM5S28A	31.10	34.40	5	10	150	28	79.0	45.4
SM5S30A	33.30	36.80	5	10	150	30	74.0	48.4
SM5S33A	36.70	40.60	5	10	150	33	68.0	53.3
SM5S36A	40.00	44.20	5	10	150	36	62.0	58.1
SM5S40A	44.40	49.10	5	10	150	40	56.0	64.5
SM5S43A	47.80	52.80	5	10	150	43	52.0	69.4

NOTE 1 : Surge current waveform is defined at 10/1000uS waveform

**Curve Characteristics**

Fig. 1 - Peak Pulse Power Rating Curve

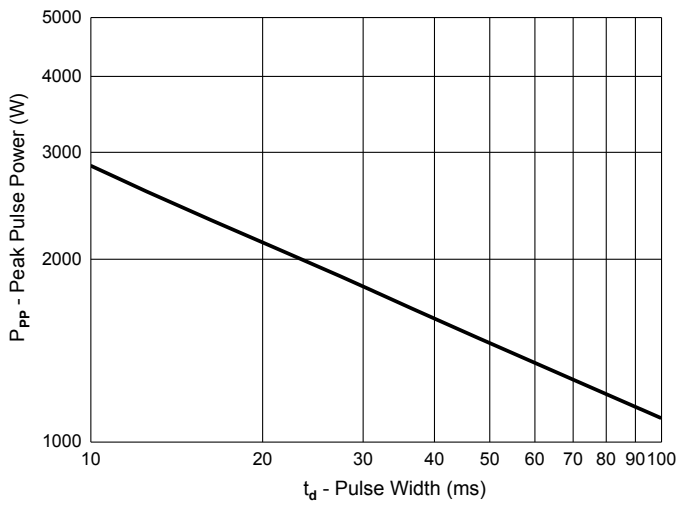

Fig. 2 - Pulse Derating Curve

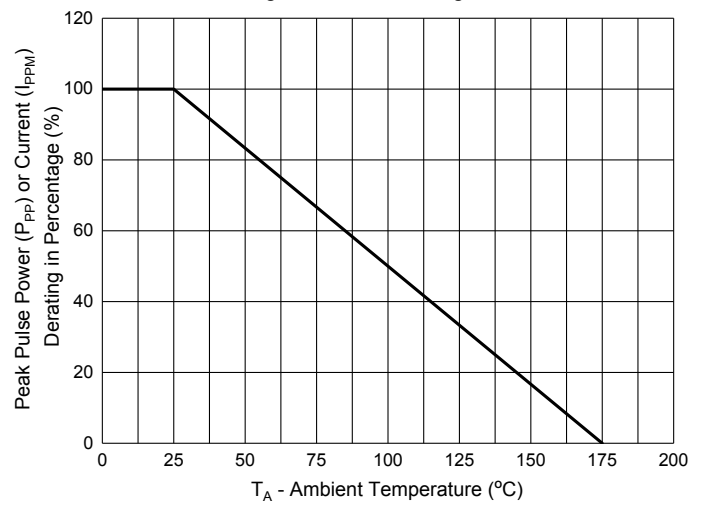

Fig. 3 - Pulse Waveform

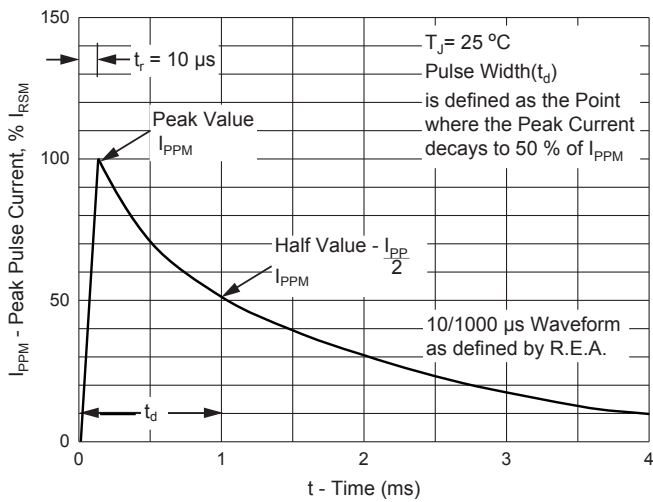

Fig. 4 - Steady State Power Derating Curve

