	E480232
---	----------------

Features

- AEC-Q101 Qualified
- Meet ISO7637-2 5a Surge Specification
- Low Leakage
- Glass Passivated Junction
- Polarity: Heatsink is Anode
- Excellent Clamping Capability
- Uni-directional Polarity
- Moisture Sensitivity Level 1
- Epoxy Meets UL 94 V-0 Flammability Rating
- Lead Free Finish/RoHS Compliant (Note1) ("P" Suffix Designates RoHS Compliant. See Ordering Information)

Maximum Ratings

- Operating Junction Temperature Range: -55°C to +175°C
- Storage Temperature Range: -55°C to +175°C

Peak Pulse Power Surge Current with a 10/1000µs Waveform	I_{PPM}	See the Table	Note 2
Peak Pulse Power Dissipation with a 10/1000µs Waveform	P_{PPM}	4600W	Note 2
Peak Pulse Power Dissipation with a 10/10000µs Waveform	P_{PPM}	3600W	
Power Dissipation On Infinite Heatsink	P_D	5.0W	$T_L=25^\circ C$
Peak forward surge current	I_{FSM}	600A	

Note: 1. High Temperature Solder Exemptions Applied, see EU Directive Annex 7a.
2. Non-repetitive current pulse, per Fig.3 and derated above $T_A=25^\circ C$ per Fig.4

**4600 Watt
TVS
10 to 43 Volts**

DO-218AB

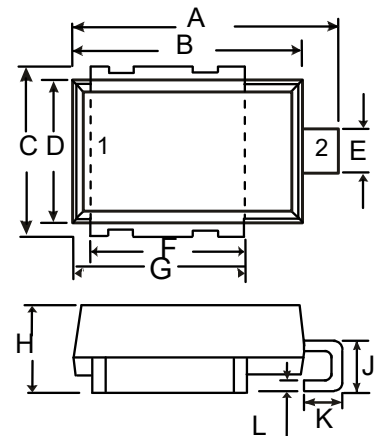

DIM	INCHES		MM		NOTE
	MIN	MAX	MIN	MAX	
A	0.590	0.630	15.00	16.00	
B	0.524	0.539	13.30	13.70	
C	0.374	0.413	9.50	10.50	
D	0.323	0.339	8.20	8.60	
E	0.091	0.114	2.30	2.90	
F	0.343	0.366	8.70	9.30	
G	0.382	0.406	9.70	10.30	
H	0.189	0.205	4.80	5.20	
J	0.098	0.138	2.50	3.50	
K	0.067	0.106	1.70	2.70	
L	0.020	0.028	0.50	0.70	

SUGGESTED SOLDER PAD LAYOUT

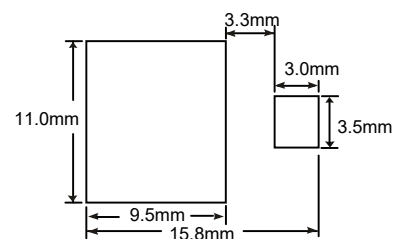

Electrical Characteristics @ 25°C Unless Otherwise Specified

MCC Part Number (Uni)	Breakdown Voltage V_{BR} @ I_T			Maximum Reverse Leakage I_R @ V_{RWM} (μA)	Maximum I_R @ V_{RWM} $T_J=175$ (μA)	Working Peak Reverse Voltage V_{RWM} (V)	Maximum Reverse Surge Current IPP (A) ⁽¹⁾	Maximum Clamping Voltage V_C @ I_{PP} (V)
	Min (V)	Max (V)	I_T (mA)					
SM6S10A	11.1	12.3	5.0	15	250	10	271	17.0
SM6S11A	12.2	13.5	5.0	10	150	11	253	18.2
SM6S12A	13.3	14.7	5.0	10	150	12	231	19.9
SM6S13A	14.4	15.9	5.0	10	150	13	214	21.5
SM6S14A	15.6	17.2	5.0	10	150	14	198	23.2
SM6S15A	16.7	18.5	5.0	10	150	15	189	24.4
SM6S16A	17.8	19.7	5.0	10	150	16	177	26.0
SM6S17A	18.9	20.9	5.0	10	150	17	167	27.6
SM6S18A	20.0	22.1	5.0	10	150	18	158	29.2
SM6S20A	22.2	24.5	5.0	10	150	20	142	32.4
SM6S22A	24.4	26.9	5.0	10	150	22	130	35.5
SM6S24A	26.7	29.5	5.0	10	150	24	118	38.9
SM6S26A	28.9	31.9	5.0	10	150	26	109	42.1
SM6S28A	31.1	34.4	5.0	10	150	28	101	45.4
SM6S30A	33.3	36.8	5.0	10	150	30	95	48.4
SM6S33A	36.7	40.6	5.0	10	150	33	86	53.3
SM6S36A	40.0	44.2	5.0	10	150	36	79	58.1
SM6S40A	44.4	49.1	5.0	10	150	40	71	64.5
SM6S43A	47.8	52.8	5.0	10	150	43	66	69.4

Note: 1.Surge current waveform is defined at 10/1000us waveform

 2.For all types maximum $V_F = 1.9V$ at $I_F = 100A$ measured on 8.3 ms single half sine-wave or equivalent square wave, duty cycle = 4 pulses per minute maximum

Curve Characteristics

Fig. 1 - Peak Pulse Power Rating Curve

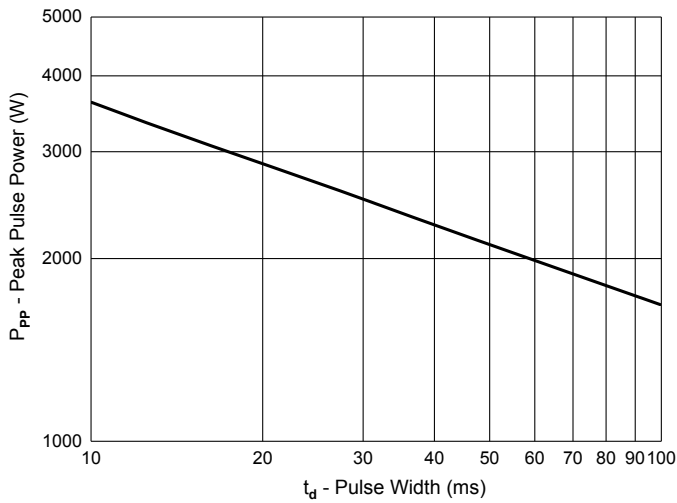

Fig. 2 - Steady State Power Derating Curve

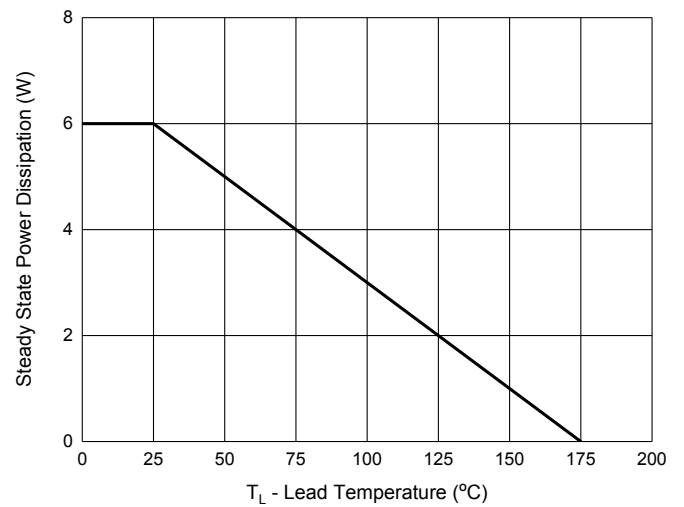

Fig. 3 - Pulse Waveform

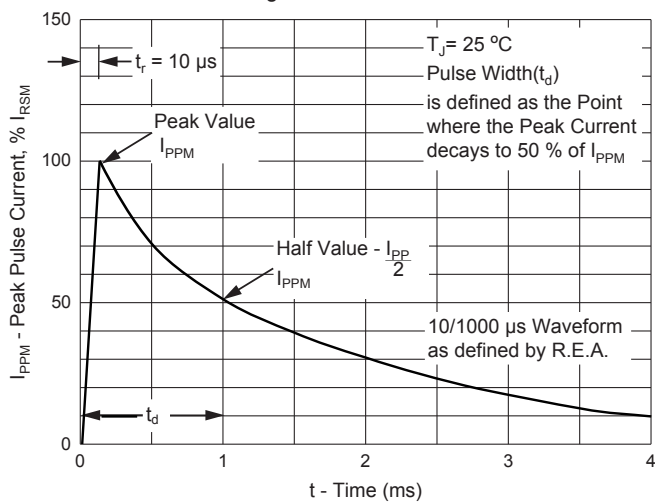

Fig. 4 - Pulse Derating Curve

