

400W, 12V - 60V Surface Mount Transient Voltage Suppressor

FEATURES

- AEC-Q101 qualified
- Glass passivated chip junction
- Maximum V_{BR} temperature coefficient: 0.095%/°C
- Moisture sensitivity level: level 1, per J-STD-020
- RoHS Compliant
- Halogen-free according to IEC 61249-2-21

APPLICATIONS

- Switching mode power supply (SMPS)
- Motor for BLDC
- Lighting application
- Battery Management System
- Automotive

MECHANICAL DATA

- Case: Thin SMA
- Molding compound meets UL 94V-0 flammability rating
- Terminal: Matte tin plated leads, solderable per J-STD-002
- Meet JESD 201 class 2 whisker test
- Polarity: Uni-directional
- Weight: 0.030g (approximately)

| KEY PARAMETERS | | |
|----------------|-------------|------|
| PARAMETER | VALUE | UNIT |
| V_{WM} | 12 - 60 | V |
| V_{BR} | 13.4 - 74.1 | V |
| P_{PPM} | 400 | W |
| T_{JMAX} | 175 | °C |
| Package | Thin SMA | |
| Configuration | Single die | |



Thin SMA



ABSOLUTE MAXIMUM RATINGS ($T_A = 25^\circ\text{C}$ unless otherwise noted)

| PARAMETER | SYMBOL | VALUE | UNIT |
|--|-----------|-------------|------|
| Non-repetitive peak impulse power dissipation with 10/1000us waveform ⁽¹⁾ | P_{PPM} | 400 | W |
| Steady state power dissipation at $T_L = 25^\circ\text{C}$ ⁽²⁾ | P_D | 7.5 | W |
| Forward Voltage @ $I_F = 25\text{A}$ for Uni-directional only ⁽³⁾ | V_F | 3.5 | V |
| Junction temperature | T_J | -55 to +175 | °C |
| Storage temperature | T_{STG} | -55 to +175 | °C |

Notes:

1. Non-repetitive current pulse per fig.3 and derated above $T_A = 25^\circ\text{C}$ per fig.1
2. Units mounted on PCB (5mm x 5mm Cu pad test board)
3. Pulse test with $PW = 0.3\text{ms}$

| THERMAL PERFORMANCE | | | |
|--|-----------------|------------|-------------|
| PARAMETER | SYMBOL | TYP | UNIT |
| Junction-to-lead thermal resistance | $R_{\theta JL}$ | 20 | °C/W |
| Junction-to-ambient thermal resistance | $R_{\theta JA}$ | 62 | °C/W |
| Junction-to-case thermal resistance | $R_{\theta JC}$ | 16 | °C/W |

Thermal Performance Note: Units mounted on PCB (5mm x 5mm Cu pad test board)

| ELECTRICAL SPECIFICATIONS ($T_A = 25^\circ\text{C}$ unless otherwise noted) | | | | | | | | |
|---|--------------|---|------|-------------------------|--|--|---|--|
| Part number | Marking code | Breakdown voltage $V_{BR}@I_T$ (V) (Note 1) | | Test current I_T (mA) | Working stand-off voltage V_{WM} (V) | Maximum blocking leakage current $I_R@V_{WM}$ (μA) (Note 1) | Maximum peak impulse current I_{PPM} (A) $t_p = 10/1000\mu\text{s}$ | Maximum clamping voltage $V_C@I_{PPM}$ (V) |
| | | Min | Max | | | | | |
| SMA4F12AH | 4F012 | 13.4 | 14.8 | 1 | 12 | 1 | 20.5 | 19.5 |
| SMA4F15AH | 4F015 | 16.8 | 18.5 | 1 | 15 | 1 | 16.4 | 24.4 |
| SMA4F18AH | 4F018 | 20.1 | 22.2 | 1 | 18 | 1 | 13.7 | 29.2 |
| SMA4F20AH | 4F020 | 22.4 | 24.7 | 1 | 20 | 1 | 12.3 | 32.5 |
| SMA4F21AH | 4F021 | 23.5 | 25.9 | 1 | 21 | 1 | 11.7 | 34.1 |
| SMA4F22AH | 4F022 | 24.6 | 27.2 | 1 | 22 | 1 | 11.2 | 35.7 |
| SMA4F24AH | 4F024 | 26.8 | 29.6 | 1 | 24 | 1 | 10.3 | 39.0 |
| SMA4F25AH | 4F025 | 27.9 | 30.9 | 1 | 25 | 1 | 9.9 | 40.6 |
| SMA4F26AH | 4F026 | 29.1 | 32.1 | 1 | 26 | 1 | 9.5 | 42.2 |
| SMA4F30AH | 4F030 | 33.5 | 37.1 | 1 | 30 | 1 | 8.2 | 48.7 |
| SMA4F33AH | 4F033 | 36.9 | 40.8 | 1 | 33 | 1 | 7.5 | 53.6 |
| SMA4F36AH | 4F036 | 40.2 | 44.5 | 1 | 36 | 1 | 6.8 | 58.4 |
| SMA4F39AH | 4F039 | 43.6 | 48.2 | 1 | 39 | 1 | 6.3 | 63.3 |
| SMA4F40AH | 4F040 | 44.7 | 49.4 | 1 | 40 | 1 | 6.2 | 64.9 |
| SMA4F43AH | 4F043 | 48.1 | 53.1 | 1 | 43 | 1 | 5.7 | 69.8 |
| SMA4F47AH | 4F047 | 52.5 | 58.1 | 1 | 47 | 1 | 5.2 | 76.3 |
| SMA4F51AH | 4F051 | 57.0 | 63.0 | 1 | 51 | 1 | 4.8 | 82.8 |
| SMA4F56AH | 4F056 | 62.6 | 69.2 | 1 | 56 | 1 | 4.4 | 90.9 |
| SMA4F60AH | 4F060 | 67.1 | 74.1 | 1 | 60 | 1 | 4.1 | 97.4 |

Note:

1. Pulse test with $PW = 30\text{ms}$

| ORDERING INFORMATION | | |
|------------------------------------|----------------|----------------------|
| ORDERING CODE⁽¹⁾ | PACKAGE | PACKING |
| SMA4FxxAH | Thin SMA | 14,000 / Tape & Reel |

Notes:

- (1) "xx" defines voltage from 12V (SMA4F12AH) to 60V (SMA4F60AH)

CHARACTERISTICS CURVES

($T_A = 25^\circ\text{C}$ unless otherwise noted)

Fig.1 Pulse Power or Current vs. Initial Junction Temperature

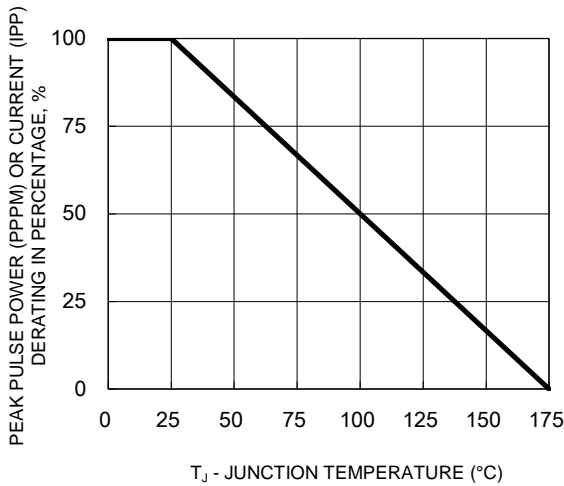

Fig.2 Steady State Power Derating

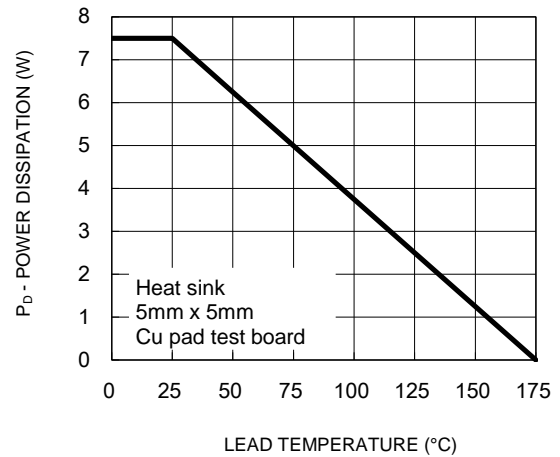

Fig.3 Clamping Power Pulse Waveform

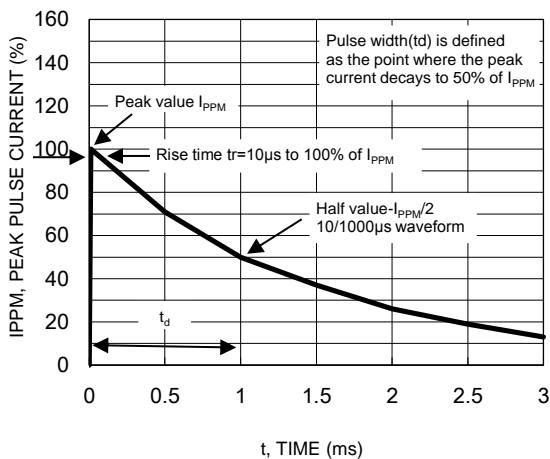

Fig.4 Typical Junction Capacitance

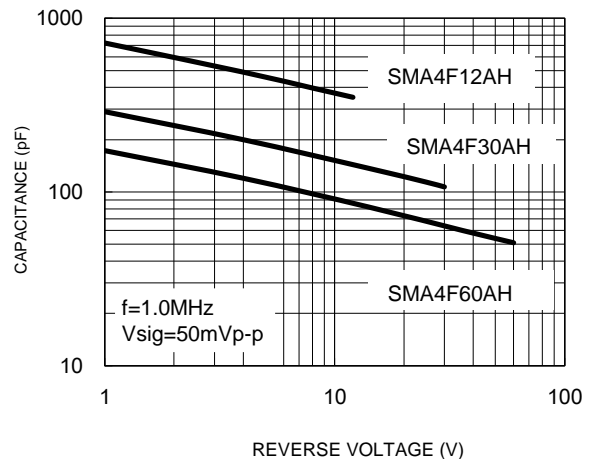
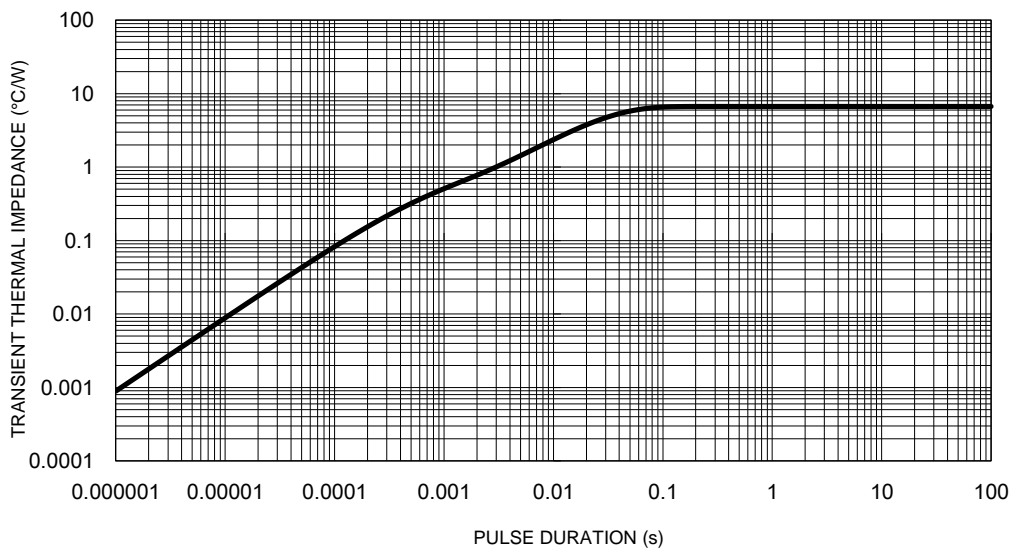
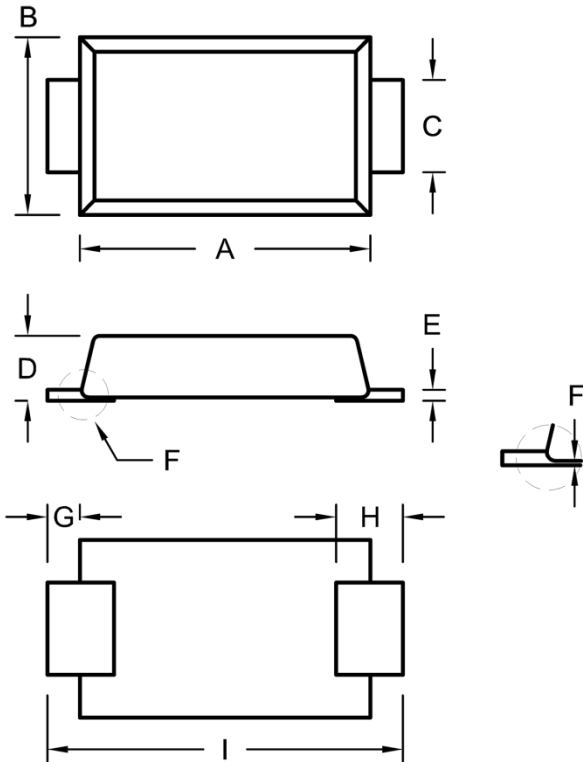

Fig.5 Typical Transient Thermal Impedance



PACKAGE OUTLINE DIMENSIONS

Thin SMA



| DIM. | Unit (mm) | | Unit (inch) | |
|------|-----------|------|-------------|-------|
| | Min. | Max. | Min. | Max. |
| A | 4.15 | 4.35 | 0.163 | 0.171 |
| B | 2.50 | 2.70 | 0.098 | 0.106 |
| C | 1.25 | 1.45 | 0.049 | 0.057 |
| D | 0.90 | 1.00 | 0.035 | 0.039 |
| E | 0.10 | 0.22 | 0.004 | 0.009 |
| F | 0.00 | 0.10 | 0.000 | 0.004 |
| G | 0.30 | 0.60 | 0.012 | 0.024 |
| H | 0.75 | 1.20 | 0.030 | 0.047 |
| I | 5.05 | 5.35 | 0.199 | 0.211 |

SUGGESTED PAD LAYOUT

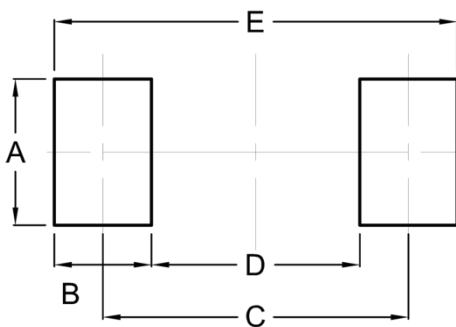

| Symbol | Unit (mm) | Unit (inch) |
|--------|-----------|-------------|
| A | 2.10 | 0.083 |
| B | 1.40 | 0.055 |
| C | 4.40 | 0.173 |
| D | 3.00 | 0.118 |
| E | 5.80 | 0.228 |

MARKING DIAGRAM

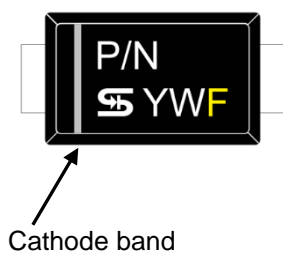

- P/N = Marking Code
- YW = Date Code
- F = Factory Code