

	E480232
---	----------------

Features

- IEC 61000-4-2 ESD 30kV(Air), 30kV (Contact)
- For Surface Mount Applications
- Unidirectional And Bidirectional
- High Surge Capability
- High Temp Soldering: 260°C / 10 Seconds At Terminals
- For Bidirectional Devices Add "C" To The Suffix of The Part Number: i.e.SMA6J9.0CA for 5% Tolerance
- Halogen Free. "Green" Device (Note 1)
- Moisture Sensitivity Level 1
- Epoxy Meets UL 94 V-0 Flammability Rating
- Lead Free Finish/RoHS Compliant (Note2) ("P" Suffix Designates RoHS Compliant. See Ordering Information)

Mechanical Data

- Polarity: Indicated by Cathode Band Except Bi-directional Types

Maximum Ratings

- Operating Junction Temperature Range: -55°C to +175°C
- Storage Temperature Range: -55°C to +175°C
- Typical Thermal Resistance: 33°C/W Junction to Lead

Peak Pulse Power Surge Current with a 10/1000µs Waveform	I_{PPM}	See the Table	Note 3
Peak Pulse Power Dissipation	P_{PPM}	600W(Min.)	Note 3,6
Steady State Power Dissipation	$P_{M(AV)}$	3.0 W	Note 5

Note:

1. Halogen free "Green" products are defined as those which contain <900ppm bromine, <900ppm chlorine (<1500ppm total Br + Cl) and <1000ppm antimony compounds.
2. High Temperature Solder Exemption Applied, see EU Directive Annex 7a.
3. Non-repetitive current pulse, per Fig.3 and derated above $T_A=25^\circ\text{C}$ per Fig.4.
4. Mounted on 5.0mm² copper pads to each terminal.
5. Lead temperature at $T_L = 75^\circ\text{C}$.
6. Peak pulse power waveform is 10/1000us.

Pin Configuration:



**600 Watt TVS
5.0 to 58 Volts**

**SMA (DO-214AC)
LEAD FRAME**

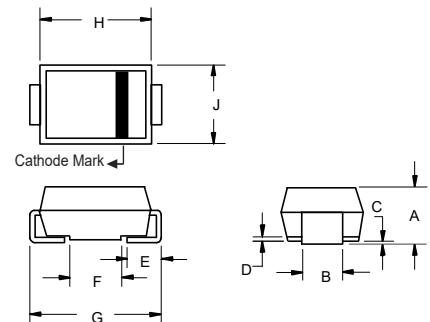

DIM	DIMENSIONS				NOTE
	INCHES		MM		
	MIN	MAX	MIN	MAX	
A	0.075	0.096	1.90	2.44	
B	0.050	0.064	1.27	1.63	
C	0.002	0.008	0.051	0.203	
D	---	0.020	---	0.51	
E	0.030	0.060	0.76	1.52	
F	0.065	0.091	1.65	2.32	
G	0.189	0.220	4.80	5.59	
H	0.157	0.187	4.00	4.75	
J	0.090	0.115	2.25	2.92	

SUGGESTED SOLDER PAD LAYOUT

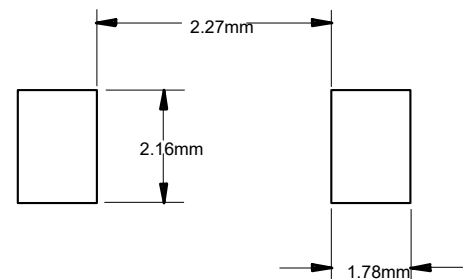

Electrical Characteristics @ 25°C Unless Otherwise Specified

MCC Part Number		Breakdown Voltage V_{BR} @ I_T			Maximum Reverse Leakage I_D (μ A) @ V_{WM}	Reverse Stand-Off Voltage V_{WM} (Volts)	Maximum Reverse Surge Current I_{pp} (A) @ 10x1000us sinewave	Maximum Clamping Voltage V_c (Volts) @ I_{pp}	Device Marking Code	
		Min. (V)	Max. (V)	I_T (mA)					Uni	Bi
SMA6J5.0A	SMA6J5.0CA	6.40	7.00	10	800	5.0	65.2	9.2	KE	TE
SMA6J6.0A	SMA6J6.0CA	6.67	7.37	10	800	6.0	58.3	10.3	KG	TG
SMA6J6.5A	SMA6J6.5CA	7.22	7.98	10	500	6.5	53.6	11.2	KK	TK
SMA6J7.0A	SMA6J7.0CA	7.78	8.60	10	200	7.0	50.0	12.0	KM	TM
SMA6J7.5A	SMA6J7.5CA	8.33	9.21	1	100	7.5	46.5	12.9	KP	TP
SMA6J8.0A	SMA6J8.0CA	8.89	9.83	1	50	8.0	44.1	13.6	KR	TR
SMA6J8.5A	SMA6J8.5CA	9.44	10.4	1	10	8.5	41.7	14.4	KT	TT
SMA6J9.0A	SMA6J9.0CA	10.0	11.1	1	5.0	9.0	39.0	15.4	KV	TV
SMA6J10A	SMA6J10CA	11.1	12.3	1	1.0	10	35.3	17.0	KX	TX
SMA6J11A	SMA6J11CA	12.2	13.5	1	1.0	11	33.0	18.2	KZ	TZ
SMA6J12A	SMA6J12CA	13.3	14.7	1	1.0	12	30.2	19.9	LE	UE
SMA6J13A	SMA6J13CA	14.4	15.9	1	1.0	13	27.9	21.5	LG	UG
SMA6J14A	SMA6J14CA	15.6	17.2	1	1.0	14	25.9	23.2	LK	UK
SMA6J15A	SMA6J15CA	16.7	18.5	1	1.0	15	24.6	24.4	LM	UM
SMA6J16A	SMA6J16CA	17.8	19.7	1	1.0	16	23.1	26.0	LP	UP
SMA6J17A	SMA6J17CA	18.9	20.9	1	1.0	17	21.7	27.6	LR	UR
SMA6J18A	SMA6J18CA	20.0	22.1	1	1.0	18	20.5	29.2	LT	UT
SMA6J19A	SMA6J19CA	21.1	23.3	1	1.0	19	19.5	30.8	LB	UB
SMA6J20A	SMA6J20CA	22.2	24.5	1	1.0	20	18.5	32.4	LV	UV
SMA6J22A	SMA6J22CA	24.4	26.9	1	1.0	22	16.9	35.5	LX	UX
SMA6J24A	SMA6J24CA	26.7	29.5	1	1.0	24	15.4	38.9	LZ	UZ
SMA6J26A	SMA6J26CA	28.9	31.9	1	1.0	26	14.3	42.1	ME	WE
SMA6J28A	SMA6J28CA	31.1	34.4	1	1.0	28	13.2	45.4	MG	WG
SMA6J30A	SMA6J30CA	33.3	36.8	1	1.0	30	12.4	48.4	MK	WK
SMA6J33A	SMA6J33CA	36.7	40.6	1	1.0	33	11.3	53.3	MM	WM
SMA6J36A	SMA6J36CA	40.0	44.2	1	1.0	36	10.3	58.1	MP	WP
SMA6J40A	SMA6J40CA	44.4	49.1	1	1.0	40	9.3	64.5	MR	WR
SMA6J43A	SMA6J43CA	47.8	52.8	1	1.0	43	8.65	69.4	MT	WT
SMA6J45A	SMA6J45CA	50.0	55.3	1	1.0	45	8.25	72.7	MV	WV
SMA6J48A	SMA6J48CA	53.3	58.9	1	1.0	48	7.75	77.4	MX	WX
SMA6J51A	SMA6J51CA	56.7	62.7	1	1.0	51	7.28	82.4	MZ	WZ
SMA6J54A	SMA6J54CA	60.0	66.3	1	1.0	54	6.89	87.1	NE	XE
SMA6J58A	SMA6J58CA	64.4	71.2	1	1.0	58	6.41	93.6	NG	XG

Note:

 *For Bi-Directional devices having V_R of 10 volts and under, the I_R limit is double .

Curve Characteristics

Fig. 1 - Peak Pulse Power Rating Curve

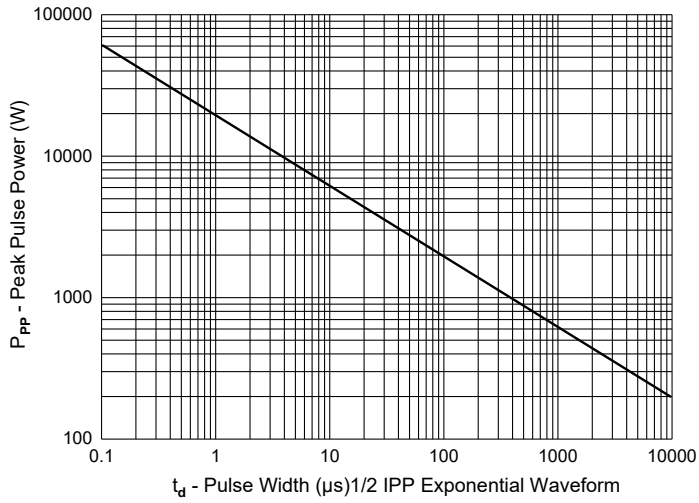

Fig. 2 - Typical Junction Capacitance

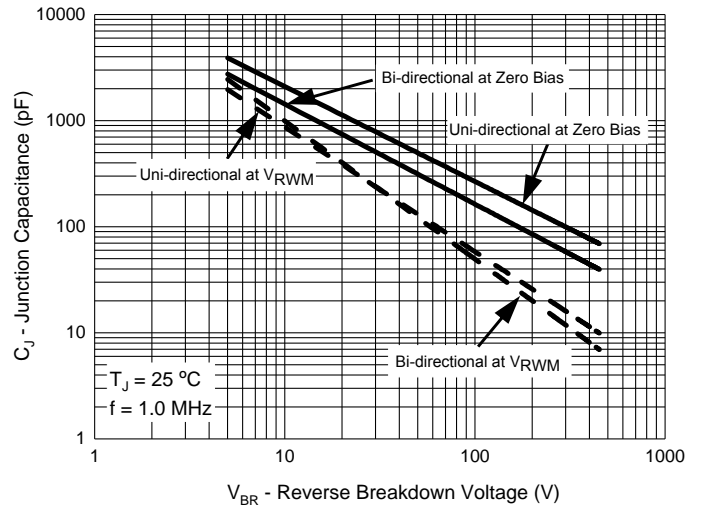

Fig. 3 - Pulse Waveform

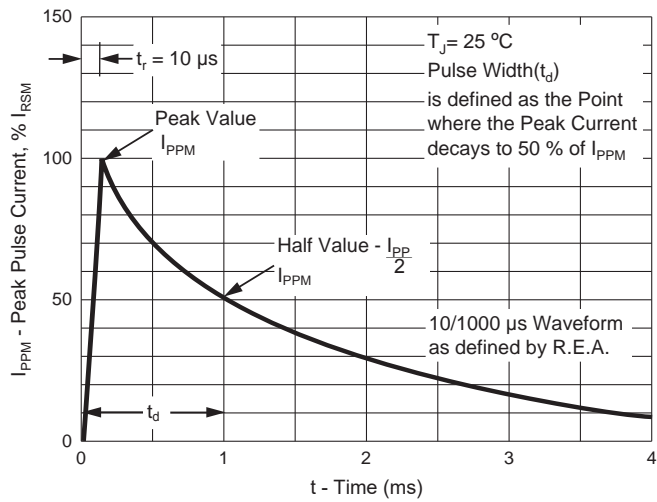

Fig. 4 - Pulse Derating Curve

