

- NOTES:**
- MOUNTING:** Mounts in a  $\phi .171 \pm .002$  [ $\phi 4.34\text{mm} \pm .05$ ] panel hole on .250 [6.35mm] centers. Panel thickness .031 [.8mm] to .094 [2.39mm]. Panel hole should be deburred, but not chamfered.
  - ASSEMBLY:** Insert lens through panel hole, slide RNG 132 retainer on back of lens. PCB mounted LEDs slide into lens when the panel cover is closed or the PCB card is inserted into the case.
  - MATERIAL:** Polycarbonate, UL 94-V2
  - U.S. & Foreign Pat. Issued & Pend.**

REVISIONS				
ECN#	REV.	DESCRIPTION	DATE	INITIALS
	001	REVISED PER ECR111009AZ01	4-23-10	SMU

RETAINER  
(ORDER SEPARATELY)

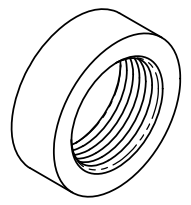

RNG 132

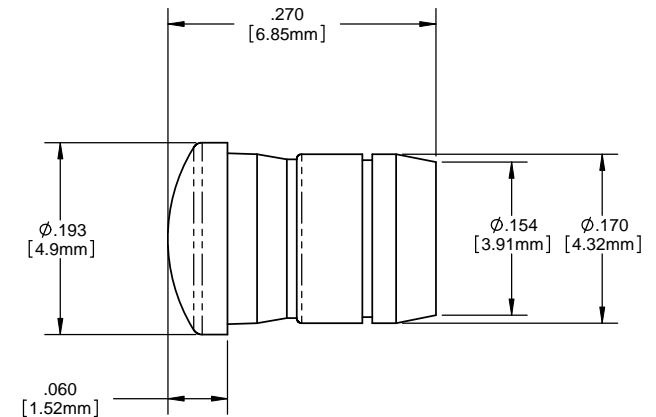
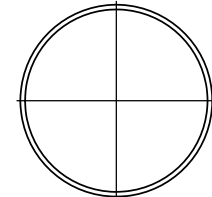
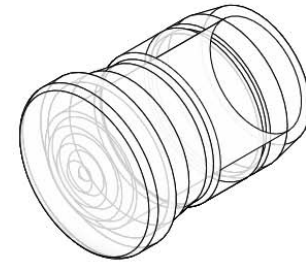

ORDERING CODE : **SMC 170 XXX**

MODEL

LENS COLOR	
RTP	RED TRANSPARENT
ATP	AMBER TRANSPARENT
GTP	GREEN TRANSPARENT
BTP	BLUE TRANSPARENT
YTP	YELLOW TRANSPARENT
CTP	CLEAR TRANSPARENT

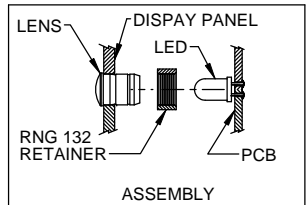

<small>UNLESS OTHERWISE SPECIFIED DIMENSIONS ARE IN INCHES</small> ANGLES DECIMALS ±1 .X ±.020 .XX ±.010 .XXX ±.005 FINISH BREAK ALL CORNERS AND SHARP EDGES (R) (R)	<b>MATERIAL</b> POLYCARBONATE, UL 94-V2	<b>VISUAL COMMUNICATIONS COMPANY, INC.</b> 190 Bosstick Boulevard, Suite 101 San Marcos, CA 92069 USA Phone (760) 560-1300 Fax (760) 560-1301 email vccsales@vccite.com															
	<b>FINISH</b> SEE NOTES	<b>TITLE: 3MM ROUND FRESNEL LOW PROFILE LENS</b>															
 <small>THIRD ANGLE PROJECTION</small>	<table border="1"> <tr> <th>APPROVAL</th> <th>DATE</th> </tr> <tr> <td>SMU</td> <td>4-23-10</td> </tr> </table>	APPROVAL	DATE	SMU	4-23-10	<table border="1"> <tr> <th>SIZE</th> <th>DWG. NO.</th> <th>REV</th> </tr> <tr> <td><b>B</b></td> <td><b>SMC 170 XXX</b></td> <td><b>001</b></td> </tr> </table>	SIZE	DWG. NO.	REV	<b>B</b>	<b>SMC 170 XXX</b>	<b>001</b>	<table border="1"> <tr> <th>SCALE:</th> <th>SHEET</th> </tr> <tr> <td>12:1</td> <td>1 OF 1</td> </tr> </table>	SCALE:	SHEET	12:1	1 OF 1
APPROVAL	DATE																
SMU	4-23-10																
SIZE	DWG. NO.	REV															
<b>B</b>	<b>SMC 170 XXX</b>	<b>001</b>															
SCALE:	SHEET																
12:1	1 OF 1																
<small>PROPRIETARY AND CONFIDENTIAL</small> <small>THE INFORMATION CONTAINED IN THIS DRAWING IS THE SOLE PROPERTY OF VISUAL COMMUNICATIONS COMPANY, INC. AND IS NOT TO BE REPRODUCED IN ANY MANNER WITHOUT THE WRITTEN CONSENT OF VISUAL COMMUNICATIONS COMPANY, INC.</small>	<table border="1"> <tr> <th>DRAWN:</th> <th>DATE</th> </tr> <tr> <td>DZ</td> <td>4-23-10</td> </tr> </table>	DRAWN:	DATE	DZ	4-23-10	<table border="1"> <tr> <th>CHECKED:</th> <th>DATE</th> </tr> <tr> <td>DZ</td> <td>4-23-10</td> </tr> </table>		CHECKED:	DATE	DZ	4-23-10						
DRAWN:	DATE																
DZ	4-23-10																
CHECKED:	DATE																
DZ	4-23-10																
<small>DO NOT SCALE DRAWING</small>		<small>SCALE: 12:1</small>															