

200W, 5V - 100V Surface Mount Transient Voltage Suppressor

FEATURES

- AEC-Q101 qualified
- Photo Glass passivated junction
- Low power loss, high efficiency
- Ideal for automated placement
- Excellent clamping capability
- Typical I_R less than $1\mu A$ above 10V
- Meets ISO 7637-2 (Pulse 1/2a/2b/3a/3b)
- 200 watts peak pulse power capability with a 10 / 1000 μs waveform ($V_{WM} \geq 60V$, $P_{PPM} = 175W$)
- Moisture sensitivity level: level 1, per J-STD-020
- RoHS Compliant
- Halogen-free according to IEC 61249-2-21

KEY PARAMETERS		
PARAMETER	VALUE	UNIT
V_{WM}	5 - 100	V
V_{BR} (uni-directional)	6.8 - 117	V
P_{PPM}	200	W
T_{JMAX}	175	°C
Package	SOD-123W	
Configuration	Single die	



APPLICATIONS

- Protect sensitive circuit from damage by high voltage transients
- Lighting, ESD transient voltage protection of IC, system
- Inductive switching load protection of IC, system
- Electrical Fast Transient Immunity protection of IC, system



SOD-123W

MECHANICAL DATA

- Case: SOD-123W
- Molding compound meets UL 94V-0 flammability rating
- Terminal: Matte tin plated leads, solderable per J-STD-002
- Meet JESD 201 class 2 whisker test
- Polarity: Indicated by cathode band
- Weight: 0.016g (approximately)



ABSOLUTE MAXIMUM RATINGS ($T_A = 25^\circ C$ unless otherwise noted)

PARAMETER	SYMBOL	VALUE	UNIT
Non-repetitive peak impulse power dissipation with 10/1000us waveform ⁽¹⁾	P_{PPM}	200	W
Steady state power dissipation at $T_L = 25^\circ C$ ⁽²⁾	P_{tot}	1	W
Forward Voltage @ $I_F = 12A$ for Uni-directional only ⁽³⁾	V_F	3.5	V
Junction temperature	T_J	-55 to +175	°C
Storage temperature	T_{STG}	-55 to +175	°C

Notes:

1. Non-repetitive Current Pulse Per Fig.3 and derated above $T_A = 25^\circ C$ Per Fig.2
2. Units mounted on PCB (5mm x 5mm Cu pad test board)
3. Pulse test with $PW = 0.3ms$

THERMAL PERFORMANCE			
PARAMETER	SYMBOL	TYP	UNIT
Junction-to-lead thermal resistance	$R_{\theta JL}$	33	°C/W
Junction-to-ambient thermal resistance	$R_{\theta JA}$	100	°C/W
Junction-to-case thermal resistance	$R_{\theta JC}$	34	°C/W

Thermal Performance Note: Units mounted on PCB (5mm x 5mm Cu pad test board)

ORDERING INFORMATION		
ORDERING CODE⁽¹⁾	PACKAGE	PACKING
SMFxAH	SOD-123W	10,000 / Tape & Reel

Notes:

1. “x” defines voltage from 5V (SMF5.0AH) to 100V (SMF100AH)

ELECTRICAL SPECIFICATIONS ($T_A = 25^\circ\text{C}$ unless otherwise noted)

Part number	Marking code	Breakdown voltage $V_{BR}@I_T$ (V) (Note 1)		Test current I_T (mA)	Working stand-off voltage V_{WM} (V)	Maximum reverse leakage current $I_R@V_{WM}$ (μA) (Note 1)	Maximum peak impulse current I_{PPM} (A) $t_p = 10/1000\mu\text{s}$	Maximum clamping voltage $V_C@I_{PPM}$ (V) $t_p = 10/1000\mu\text{s}$
		Min	Max					
SMF5.0AH	2W5P0	6.4	7.0	10	5	800	21.7	9.2
SMF6.0AH	2W6P0	6.67	7.37	10	6	800	19.4	10.3
SMF6.5AH	2W6P5	7.22	7.98	10	6.5	500	17.9	11.2
SMF7.0AH	2W7P0	7.78	8.6	10	7.0	200	16.7	12.0
SMF7.5AH	2W7P5	8.33	9.21	1	7.5	100	15.5	12.9
SMF8.0AH	2W8P0	8.89	9.83	1	8.0	50	14.7	13.6
SMF8.5AH	2W8P5	9.44	10.5	1	8.5	10	13.9	14.4
SMF9.0AH	2W9P0	10.0	11.1	1	9.0	5	13.0	15.4
SMF10AH	2W010	11.1	12.3	1	10	5	11.8	17.0
SMF11AH	2W011	12.2	13.5	1	11	1	11.0	18.2
SMF12AH	2W012	13.3	14.7	1	12	1	10.1	19.9
SMF13AH	2W013	14.4	15.9	1	13	1	9.3	21.5
SMF14AH	2W014	15.6	17.2	1	14	1	8.6	23.2
SMF15AH	2W015	16.7	18.5	1	15	1	8.2	24.4
SMF16AH	2W016	17.8	19.7	1	16	1	7.7	26.0
SMF17AH	2W017	18.9	20.9	1	17	1	7.2	27.6
SMF18AH	2W018	20.0	22.1	1	18	1	6.8	29.2
SMF20AH	2W020	22.2	24.5	1	20	1	6.2	32.4
SMF22AH	2W022	24.4	26.9	1	22	1	5.6	35.5
SMF24AH	2W024	26.7	29.5	1	24	1	5.1	38.9
SMF26AH	2W026	28.9	31.9	1	26	1	4.8	42.1
SMF28AH	2W028	31.1	34.4	1	28	1	4.4	45.4
SMF30AH	2W030	33.3	36.8	1	30	1	4.1	48.4
SMF33AH	2W033	36.7	40.6	1	33	1	3.8	53.3
SMF36AH	2W036	40.0	44.2	1	36	1	3.4	58.1
SMF40AH	2W040	44.4	49.1	1	40	1	3.1	64.5
SMF43AH	2W043	47.8	52.8	1	43	1	2.9	69.4
SMF45AH	2W045	50.0	55.3	1	45	1	2.8	72.7
SMF48AH	2W048	53.3	58.9	1	48	1	2.6	77.4
SMF51AH	2W051	56.7	62.7	1	51	1	2.4	82.4
SMF54AH	2W054	60.0	66.3	1	54	1	2.3	87.1
SMF58AH	2W058	64.4	71.2	1	58	1	2.1	95
SMF60AH	2W060	66.7	73.7	1	60	1	1.8	96.8
SMF64AH	2W064	71.1	78.6	1	64	1	1.7	103
SMF70AH	2W070	77.8	86	1	70	1	1.55	113
SMF75AH	2W075	83.3	92.1	1	75	1	1.45	121
SMF78AH	2W078	86.7	95.8	1	78	1	1.4	126
SMF85AH	2W085	94.4	104	1	85	1	1.3	137
SMF90AH	2W090	100	111	1	90	1	1.2	146
SMF100AH	2W100	111	123	1	100	1	1.08	162

Notes:

1. Pulse test with PW = 30ms

CHARACTERISTICS CURVES

($T_A = 25^\circ\text{C}$ unless otherwise noted)

Fig.1 Pulse Power or Current vs. Initial Junction Temperature

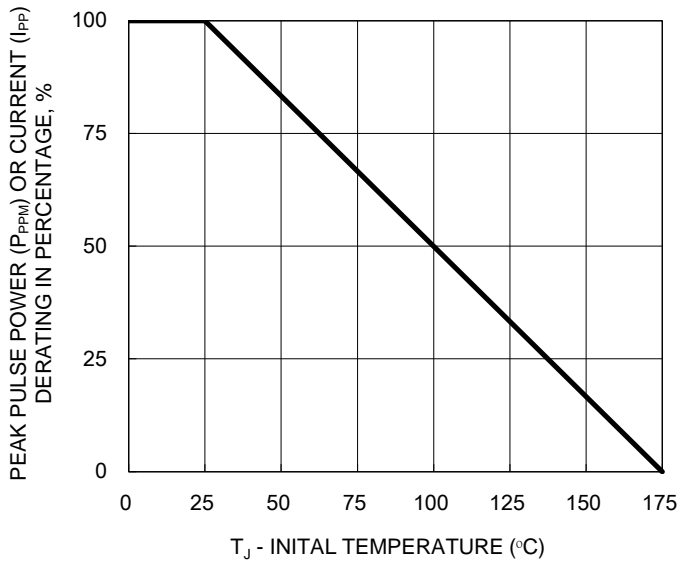

Fig.2 Steady State Power Derating

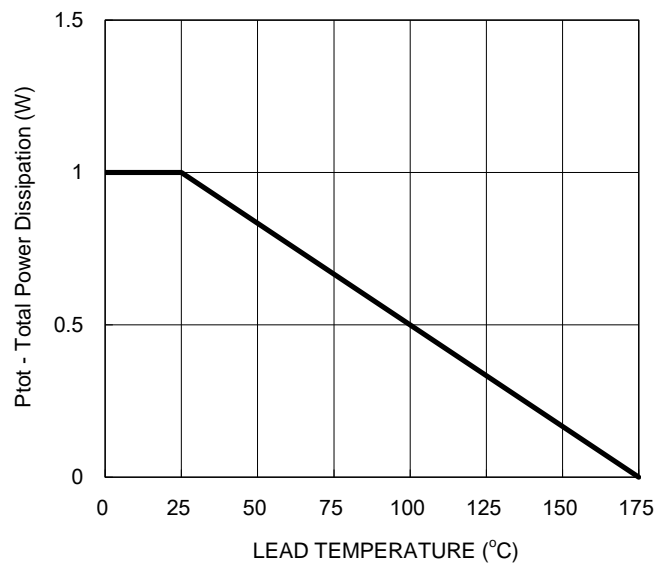

Fig.3 Clamping Power Pulse Waveform

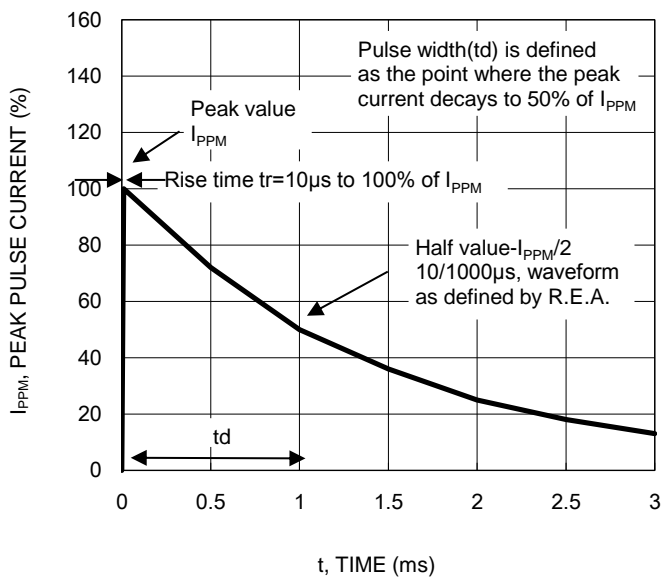
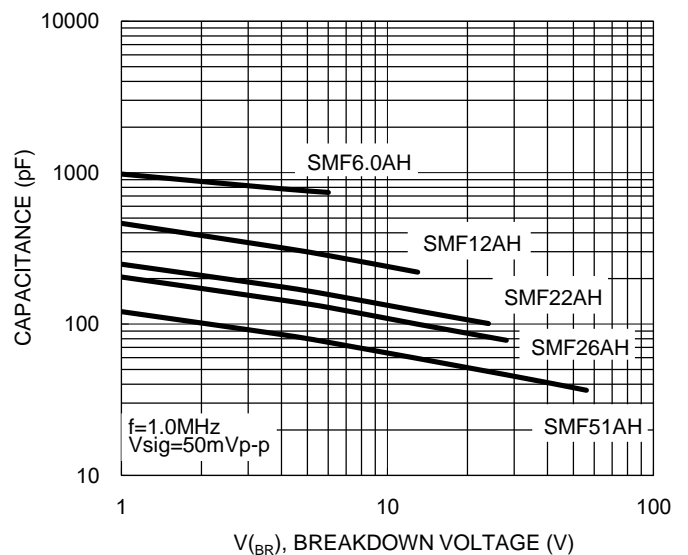
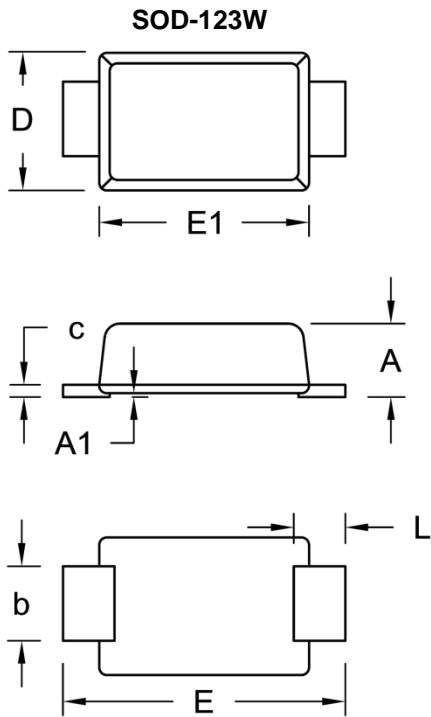

Fig.4 Typical Junction Capacitance



PACKAGE OUTLINE DIMENSIONS



DIM.	Unit (mm)		Unit (inch)	
	Min.	Max.	Min.	Max.
A	0.90	1.02	0.035	0.040
A1	0.00	0.10	0.000	0.004
b	0.90	1.05	0.035	0.041
c	0.10	0.22	0.004	0.009
D	1.70	1.90	0.067	0.075
E	3.60	3.80	0.142	0.150
E1	2.60	2.90	0.102	0.114
L	0.50	0.85	0.020	0.033

SUGGESTED PAD LAYOUT

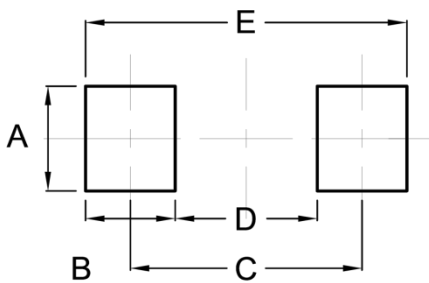

Symbol	Unit (mm)	Unit (inch)
A	1.40	0.055
B	1.20	0.047
C	3.10	0.122
D	1.90	0.075
E	4.30	0.169

MARKING DIAGRAM



P/N = Marking Code
 YW = Date Code
 F = Factory Code