

# SMI30 Series Sensor



## Datasheet

No revision without agency approval.

To view or download the latest technical information about this product, including specifications, dimensions, accessories, and wiring, go to [www.bannerengineering.com](http://www.bannerengineering.com).



- Designed for use with approved amplifiers and intrinsically safe barriers in explosive environments
- Very high excess gain; 350 foot range (standard 10 ms models)
- Fast 1 ms response models (152 foot range) available by special order
- Totally sealed, self-contained, threaded-barrel opposed mode sensor pairs in rugged 30 mm PBT housings
- Highly immune to noise: the best noise immunity of any self-contained emitter/receiver pair
- Internal alignment indicator LED may be viewed either from the side or from the front of the receiver through the lens
- Integral mini-type 3-pin "QD" (quick-disconnect) connector



### WARNING:

- **Do not use this device for personnel protection**
- Using this device for personnel protection could result in serious injury or death.
- This device does not include the self-checking redundant circuitry necessary to allow its use in personnel safety applications. A device failure or malfunction can cause either an energized (on) or de-energized (off) output condition.

## Models

Response Time		Models		
		Frequency "A" (standard)	Frequency "B" (special order)	Frequency "C" (special order)
Models with 10 ms response time		Repeatability: 1 ms	Repeatability: 1.6 ms	Repeatability: 2.3 ms
	Emitters	<b>SMI306EQ</b>	<b>SMI306EBQ</b>	<b>SMI306ECQ</b>
	Receivers (light operate)	<b>SMI30AN6RQ</b>	<b>SMI30AN6RBQ</b>	<b>SMI30AN6RCQ</b>
	Receivers (dark operate)	<b>SMI30RN6RQ</b>	<b>SMI30RN6RBQ</b>	<b>SMI30RN6RCQ</b>
Models with 1 ms response time		Repeatability: 360 $\mu$ s		Repeatability: 210 $\mu$ s
	Emitters	<b>SMI306EYQ</b>		<b>SMI306EYCQ</b>
	Receivers (light operate)	<b>SMI30AN6RYQ</b>		<b>SMI30AN6RYCQ</b>
	Receivers (dark operate)	<b>SMI30RN6RYQ</b>		<b>SMI30RN6RYCQ</b>

## Overview

Banner SMI30 Series intrinsically safe barrel sensors are extremely rugged and powerful opposed mode infrared sensor pairs designed for the most demanding industrial applications. Their high excess gain (350 foot range) provides enough sensing power to penetrate the heaviest contamination (see Excess Gain Curve). Electronics are fully epoxy-encapsulated for maximum resistance to mechanical shock and vibration. Positive sealing at both ends, with no exposed epoxy interfaces, eliminates all leak paths (including capillary leakage). Construction exceeds NEMA 6P (IEC IP 67) standards. Sensors are approximately 1.2 inches in diameter by 4 inches long. SMI30 series dc receivers operate from 10 to 30 V dc.

SMI30 Series sensors are certified as being intrinsically safe when used with approved intrinsic safety barriers. SMI30 Series sensors are suitable for intrinsically safe use in hazardous locations as listed in the Approvals table (see [SMI30 Specifications](#) on p. 4). SMI30 Series sensors are also certified as non-incendive devices when used in Class I, Division 2, Groups A, B, C, and D locations without intrinsic safety barriers.

SMI30 Series sensors may be wired for either two- or three-wire current-sinking operation. In the three-wire hookup, which requires two intrinsic-safety barriers (or one dual barrier), the sink current is 15 mA. The two-wire hookup, which requires one barrier, sinks  $\leq 10$  mA (OFF state) and  $\geq 20$  mA (ON state).

Intrinsic safety barriers and current trip point amplifier model CI3RC2 are also available (see [Accessories](#) on p. 5).

SMI30 Series receivers have a red LED alignment indicator that lights whenever the receiver "sees" its modulated light source. Emitters have a red LED to indicate "power on". All LED indicators are mounted internally to preserve the waterproof integrity of the sensor housing, and are visible from both the side and front of the sensor through the sensor's quad-ring sealed acrylic lens.

The innovative circuitry used in SMI30 Series emitters and receivers provides the best noise immunity of any self-contained opposed mode sensor pair. For applications where optical crosstalk between sensors might be a problem, SMI30 Series emitters and receivers are available with a choice of three modulation frequencies (frequency "A", frequency "B", or frequency "C"). This makes it possible to use high-powered sensor pairs of different frequencies in close proximity to each other without crosstalk. (NOTE: frequency "A" is standard; frequencies "B" and "C" are available by special order. An emitter and its receiver must be of the same modulation frequency.) See the models table for a summary of models.

Each unit is supplied with two hexagonal jam nuts. A 30 mm clearance hole is required for mounting, and mounting bracket models SMB30MM, SMB30S, and SMB30C are available. All models have a built-in standard quick-disconnect ("QD") connector. "QD" models mate with 12-foot long model SMICC-312 or 30-foot long model SMICC-330 mini-type QD cable (sold separately from sensor).



## Installation Instructions

### Ex/HazLoc Applications

**WARNING:**

- **Explosive Atmospheres/Hazardous Locations**
- It is the user's responsibility to ensure that all local, state, and national laws, rules, codes, or regulations relating to the installation and use of this device in any particular application are satisfied. This device must be installed by a Qualified Person<sup>†</sup>, in accordance with this document and applicable regulations.

**WARNING:**

- **Explosion Hazard**
- Do not disconnect equipment unless the power has been switched off or the area is known to be non-hazardous.

**CAUTION:**

- **Electrostatic Discharge (ESD) Special Conditions for Safe Use**
- Parts of the enclosure are non-conducting and can generate an ignition-capable level of ESD.
- Clean the equipment with only a damp cloth.

**General Notes and Conditions for Use:**

- See Specifications and Wiring Diagrams for important information concerning entity parameters, permissible locations, electrical connections and certifications.
- In addition to the warning above concerning user responsibility, the installation must comply with the following:
  - All installations must comply with all manufacturer's instructions.
  - U.S. Installations: The relevant requirements of the National Electrical Code<sup>®</sup> (ANSI/NFPA-70 (NEC<sup>®</sup>)) and when appropriate ANSI/ISA-RP12.06.01 Installation of Intrinsically Safe Systems for Hazardous (Classified) Locations.
  - Canadian Installations: The relevant requirements of the Canadian Electrical Code (CSA C22.1).
  - ATEX and IECEx Installations: The relevant requirements of EN 60079-14 and applicable National regulations.
  - For quick disconnect (QD) models only: Use Banner **SMICC9-3##** cordsets (see [Accessories](#) on p. 5) or suitable quick disconnect cordsets with threaded retaining nut (see [SMI30 Specifications](#) on p. 4). The cordset must be securely fastened using the QD retaining nut to prevent disconnection.
- Do not attempt any repairs to this device; it contains no field-replaceable parts or components. Tampering and/or replacement with non-factory components may adversely affect the safe use of the system.
- Barrier entity parameters must meet the following requirements:
  - $V_{oc} \text{ or } V_t \leq V_{max}$
  - $C_a \geq C_i + C_{cable}$
  - $I_{sc} \text{ or } I_t \leq I_{max}$
  - $L_a \geq L_i + L_{cable}$
- If barriers with Volt/Ohm parameters are used, the following parameters shall apply:
  - One Single-Channel Barrier Systems—one 28 V (max), 300  $\Omega$  (min)
  - Two Single-Channel Barrier or One Dual-Channel Systems
    - two 28 V (max), 600  $\Omega$  (min)
    - one 28 V (max), 300  $\Omega$  (min) and one 10 V (max), 50  $\Omega$  (min)
    - one 28 V (max), 300  $\Omega$  (min) and one 28 V diode return
- Sensor Entity Parameters
  - $V_{max} (U_i) \leq 30 \text{ V DC}$
  - $I_{max} (I_i) \leq 350 \text{ mA}$
  - $P_i \leq 750 \text{ mW}$
  - $C_i = 0 \mu\text{F}$
  - $L_i = 0 \text{ mH}$
- The ambient operating temperature range of the sensors is  $-40 \text{ }^\circ\text{C}$  to  $+70 \text{ }^\circ\text{C}$  ( $-40 \text{ }^\circ\text{F}$  to  $+158 \text{ }^\circ\text{F}$ ).
- The sensors are suitable for installation without barriers in Class I Div. 2 Groups A, B, C, D; Class II Div. 2 Group G; and Class III Div. 2, when installed in (or through the wall of) a suitable enclosure with provision for connection of rigid metal conduit per the National Electrical Code, as acceptable to the local inspection authority having jurisdiction. In Div. 2 installations (without barriers), observe Explosion Hazard warning at the beginning of this section.
- The sensors are suitable for installation without barriers in Class I Div. 2 Groups A, B, C, D when installed in (or through the wall of) a suitable enclosure with provision for connection of rigid metal conduit per the Canadian Electrical Code, as acceptable to the local inspection authority having jurisdiction. In Div. 2 installations (without barriers), observe Explosion Hazard warning at the beginning of this section.
- Maximum non-hazardous area voltage that the Intrinsically safe barrier is connected to must not exceed 250 V.
- Control (Installation) Drawing p/n 35392 has been replaced by this document.

### Wiring Connections

The SMI30 Series sensor is intrinsically safe ONLY when used with certified energy-limiting intrinsically safe barriers. Banner does not manufacture such barriers; however, our applications engineers can refer you to suppliers of certified barriers that will interface with Banner sensors. SMI30 Series sensors may be wired using Banner Current Amplifier Control Module C13RC2. Note from the wiring diagrams that the installation may be made with either a single barrier (2-wire hookup) or with a double barrier (3-wire hookup). Emitter-only units (SMI30EQD, ESRQD, and EFQD) use the 2-wire hookup; all other models use either 2- or 3-wire hookup.

In the 2-wire configuration, the sensor will act as a current sink, drawing less than 10 mA in the OFF state and more than 20 mA in the ON state. The user must provide a current sensing device ("current sensor" in the diagram) to convert the current to a logic level. In the 3-wire configuration, the output may be used directly to control loads of less than 15 mA.

In selecting the barrier, it is important to consider the barrier's resistance. The sensor must have at least 10 volts across the brown and blue power leads for proper operation, and the barrier will cause a voltage drop due to its resistance. The formula that determines how much resistance is allowed is:  **$R = 40$  (supply voltage – 10 volts).**

If the supply voltage is 24 V dc, then the maximum resistance is 560 ohms. If the supply voltage is 18 V dc, then the maximum resistance is 320 ohms. This includes the resistance of any current sensing device used (in the 2-wire configuration), so the barrier resistance must be further reduced by the current sensor resistance.

Note that, in the 3-wire hookup, the positive load barrier is in series with the load. This will result in an apparent saturation voltage of the output that is higher than the sensor output by the amount of  $I \times R$  (current times resistance) drop through the barrier.

<sup>†</sup> A Qualified Person is a person who, by possession of a recognized degree or certificate of professional training, or who, by extensive knowledge, training and experience, has successfully demonstrated the ability to solve problems relating to the subject matter and work.

A "positive input" barrier is required for both supply and for load. The sensor's blue (negative supply) lead is normally connected to the ground terminal of the barrier.

The user is responsible for proper installation and maintenance of this equipment, and must conform with the certification requirements relating to barriers and to maximum allowable capacitance and inductance of the field wiring. If in doubt about these requirements, our applications engineers can refer you to the appropriate authority.

Figure 1. Wiring for 3-Wire Connections

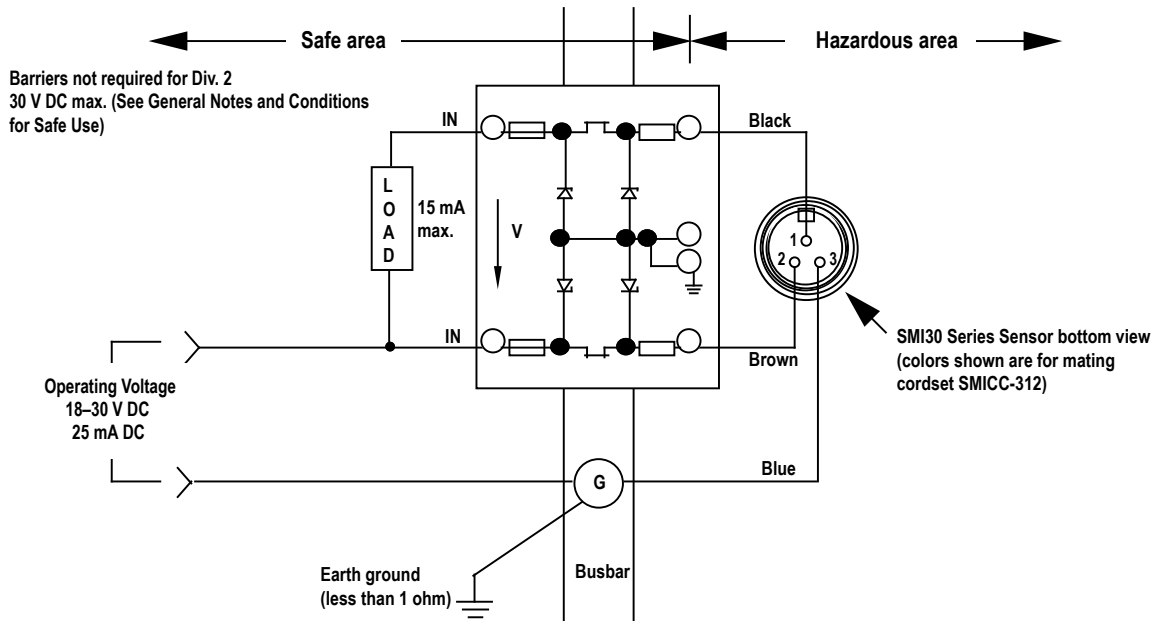

Note: Emitters have no output connection (no connection to black wire)

Figure 2. Wiring for 2-Wire Connections

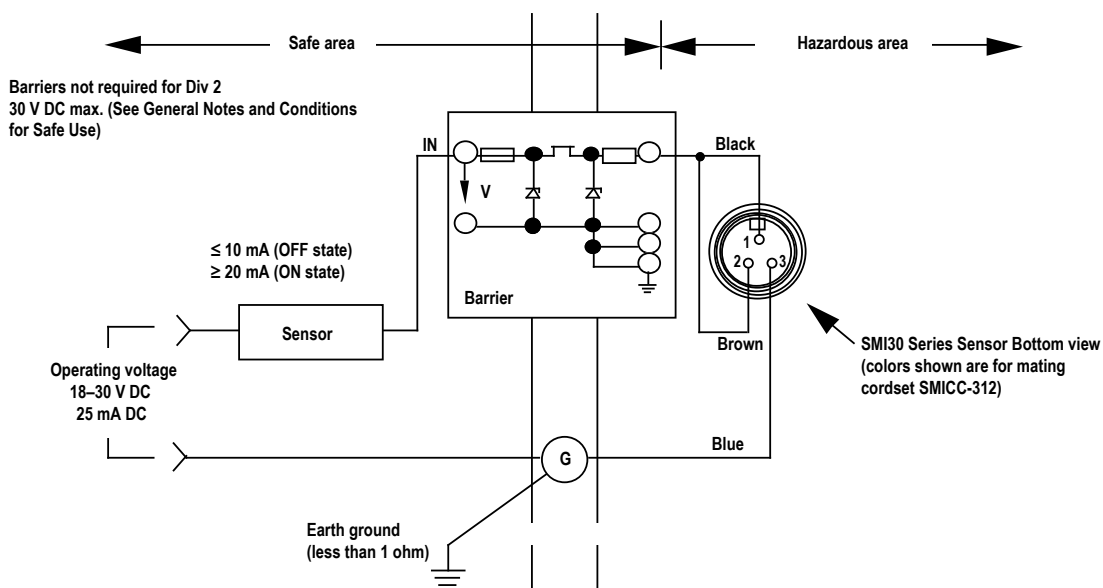

## SMI30 Specifications

### Supply Voltage and Current

Emitters: 10 to 30 V DC at 25 mA  
 Receivers: 10 to 30 V DC at 15 mA maximum Division 1 use, with barriers, requires minimum system supply voltage of 10 V. See [Wiring Connections](#) on p. 2.

### Sensing Beam

880 nanometers, infrared; effective beam size 0.75 inch diameter

### Indicator

Internal red LED lights whenever the receiver sees its modulated light source. Emitters have red "power on" indicator LED. All indicators are visible through the lens or from side of the sensor.

### Construction

Banner tested to NEMA 6P, IEC IP67  
 30 mm diameter tubular threaded PBT housing, positive sealing at both ends; quad-ring sealed acrylic lens. Electronics are fully epoxy encapsulated. Two PBT jam nuts are provided.

### Mounting Alternatives

30 mm clearance hole  
 SMB30C split clamp mounting bracket; SMB30MM two-axis mounting bracket;  
 SMB30S swivel mounting bracket. See [APG30S Aperture Kit](#) on p. 6

### Cable

Three-wire 7/8 in-16UNF QD cable (12 ft. long model SMICC-312 or 30 ft. long model SMICC-330)  
 Cable electrical properties: 40 pf/ft.; 0.20  $\mu$ H/ft  
 Order cable separately from sensor

### Connections

Connecting 3-pin 7/8-16 7/8 in-16UNF QD Cordsets (see [Cordsets](#) on p. 6): Female single-ended  
 Multiconductor cable (at minimum): UL Style 2517, 22 AWG wire, rated  $\geq 80^\circ\text{C}$   
 MINI QD connector: must have threaded 7/8-16 UN retaining nut

### Application Note

Special Conditions for Safe Use: Parts of the enclosure are non-conducting and may generate an ignition-capable level of ESD. Cleaning of the equipment must be done only with a damp cloth

### Output Rating

Receivers only: Current sinking NPN open-collector transistor. Three-wire hookup sinks 15 mA maximum continuous, 10 to 30 V DC. Two-wire hookup sinks  $\leq 10$  mA (OFF state) and  $\geq 20$  mA (ON state), 10 to 30 V DC. Outputs are short-circuit protected.

### Response Time

10 milliseconds on/off (models with 1 ms response are available by special order)

### Repeatability

See excess gain curve. Response Time and Repeatability specifications are independent of signal strength.

### Operating Temperature

$-40^\circ\text{C}$  to  $+70^\circ\text{C}$  ( $-40^\circ\text{F}$  to  $+158^\circ\text{F}$ )

### Certifications



**Banner Engineering Europe** Park Lane,  
 Culliganlaan 2F bus 3, Diegem B-1831  
 BELGIUM



**Turck Banner LTD** Blenheim House, Blenheim Court,  
 Wickford, Essex SS11 8YT, Great Britain



IEC IECEX FMG 14.0029X  
 ATEX FM12ATEX0094X  
 FM21UKEX0211X  
 FM CoC 0003046293 (US)  
 FM CoC 0003046293C (CAN)

Design Standards	
ATEX (European)	EN IEC 60079-0, EN 60079-11
Canada	CAN/CSA C22.2: No.0-M91, No.142-M1987, No.157-92, No.213-M1987, No.1010.1, E60079-0 and E60079-11
United States	FM Class 3600, 3610, and 3810; ANSI/ISA 61010-1 (82.02.01), 60079-0 and 60079-11
IECEX	IEC 60079-0, IEC 60079-11

Approvals	
<b>SMI30(a)</b>	a = 6EQ, 6EBQ, 6ECQ, 6EYQ, AN6RQ, AN6RBQ, AN6RCQ, RN6RQ, RN6RBQ, RN6RCQ, 6EYQ, AN6RYQ, AN6RYCQ, RN6RYQ, RN6RYCQ.
ATEX (European)	II 2 G Ex ib IIC T5 Gb Ta = $-40^\circ\text{C}$ to $70^\circ\text{C}$ - 35331; Entity Parameters: $U_i = 30$ V, $I_i = 350$ mA, $P_i = 750$ mW, $C_i = 0$ , $L_i = 0$ .
Canadian	I / 1 / Ex ib / IIC / T5 Ta = $-40^\circ\text{C}$ to $70^\circ\text{C}$ - 35331; Entity CL I, Zn 1 Ex ib IIC T5 $-40^\circ\text{C} \leq Ta \leq +70^\circ\text{C}$ ; Entity 35331 (Non-incendive) NI / I,II,III / 2 / ABCDG / T5 Entity Parameters: $V_{Max} = 30$ V, $I_{Max} = 350$ mA, $P_i = 750$ mW, $C_i = 0$ , $L_i = 0$ .
United States	I / 1 / AEx ib / IIC / T5 Ta = $-40^\circ\text{C}$ to $70^\circ\text{C}$ - 35331; Entity CL I, Zn 1 AEx ib IIC T5 Gb $-40^\circ\text{C} \leq Ta \leq +70^\circ\text{C}$ ; Entity 35331 (Non-incendive) NI / I,II,III / 2 / ABCDG / T5 Ta = $-40^\circ\text{C}$ to $70^\circ\text{C}$ Entity Parameters: $V_{Max} = 30$ V, $I_{Max} = 350$ mA, $P_i = 750$ mW, $C_i = 0$ , $L_i = 0$ .
IECEX	Ex ib IIC T5 Gb Ta = $-40^\circ\text{C}$ to $+70^\circ\text{C}$ - 35331; Entity Parameters: $V_{Max} = 30$ V, $I_{Max} = 350$ mA, $C_i = 0$ , $L_i = 0$

XXXXXXXXXXXXXXXXXXXX

Banner Engineering Corp.  
 Mpls, MN 55441 USA



10 to 30 V DC, 25 mA  
 INSTALL PER DRAWING 35331

EXIA



II 2 G Ex ib IIC T5 Gb  
 Ta =  $-40^\circ\text{C}$  to  $+70^\circ\text{C}$

FM12ATEX0094X IECEX FMG 14.0029X



FM21UKEX0211X  
 FM20US0068X  
 FM20CA0032X

UK  
 CA 1725

CLI, Zn 1 AEx ib IIC T5 Gb

## Performance Curves

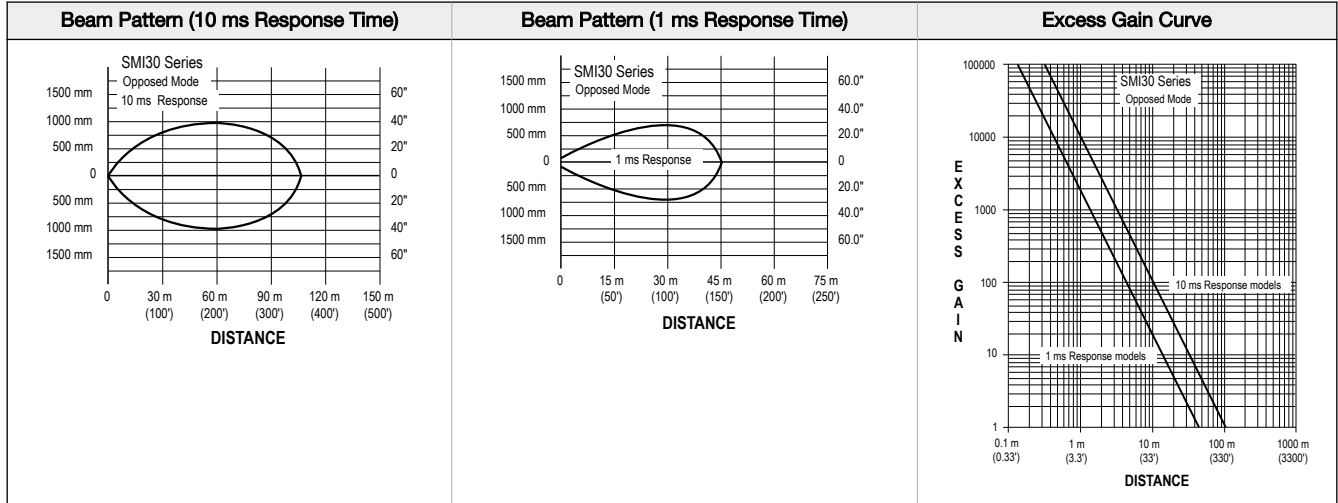

## Dimensions

All measurements are listed in millimeters [inches], unless noted otherwise. Connector not shown.

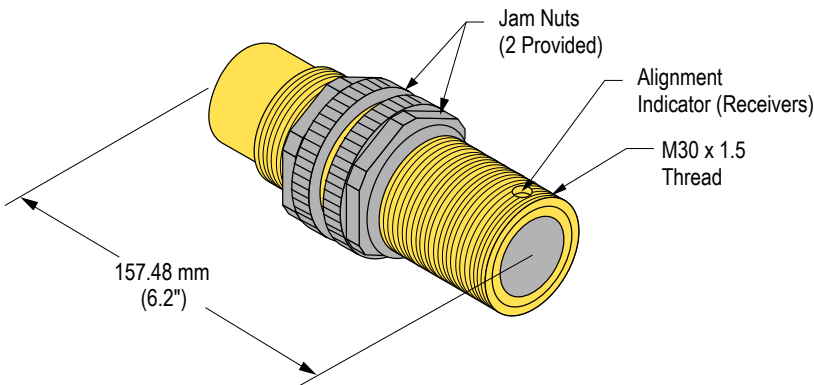

## Accessories

### Brackets

#### SMB30C

- 30 mm split clamp, black PBT bracket
- Stainless steel mounting hardware included
- Mounting hole for 30 mm sensor

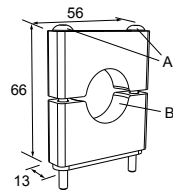

Hole center spacing: A =  $\phi$  45  
Hole size: B =  $\phi$  27.2

#### SMB30MM

- 12-ga. stainless steel bracket with curved mounting slots for versatile orientation
- Clearance for M6 (1/4 in) hardware
- Mounting hole for 30 mm sensor

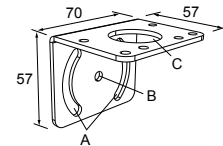

Hole center spacing: A = 51, A to B = 25.4  
Hole size: A = 42.6 x 7, B =  $\phi$  6.4, C =  $\phi$  30.1

#### SMB30S

- Swivel bracket with 30 mm mounting hole for sensor
- Adjustable captive swivel ball
- Black reinforced thermoplastic polyester
- Stainless steel mounting and swivel locking hardware included

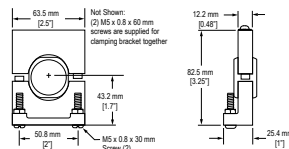

**Special Conditions for Safe Use.** Parts of the enclosure are non-conducting and may generate an ignition-capable level of ESD. Clean the equipment with a damp cloth only.

### APG30S Aperture Kit

These new water-tight apertures for SM30 Series sensors may be used to size and shape the effective beam or to limit excess gain for avoiding "burn-through" effects. Apertures are sold as a kit, which includes a thread-on stainless steel housing, a flat glass lens, two quad-ring seals, and 3 round and 3 slotted aperture disks.

The stainless steel aperture housing functions equally well with VALOX® and stainless steel sensor models. The glass lens is useful for protecting the SM30's acrylic lens against substances that are hostile to acrylics, such as concentrated acids and alkalis and industrial solvents.

Aperture sizes include the following:

- Round: .06", .12", and .70" diameter
- Slotted: .04", .10", and .20" wide

#### APG30S

Kit includes round apertures of 0.05 in, 0.12 in, and 0.70 in diameter; slotted widths of 1 mm (0.04 in), 0.10 in and 0.20 in. Used with SM30 and SMI30 models.



### Cordsets

3-pin 7/8-In Cordsets for Intrinsically Safe Sensors—Single Ended				
Model	Length	Style	Dimensions (mm)	Pinout (Female)
SMICC-306	2 m (6.56 ft)	Threaded, straight		<p>1 = Black 2 = Brown 3 = Blue</p>
SMICC-312	4 m (13.12 ft)			
SMICC-330	10 m (32.81 ft)			

### Intrinsic Safety Barriers

Model (Barrier Only)	Barrier Description	Kit Model	Kit Description
CI3B-1	Single-channel intrinsically safe barrier	CI2BK-1	Includes CI3RC2 current amplifier, one RS-11 socket, one DIN-rail mount, one single-channel intrinsically safe barrier
CI2B-1	Dual-channel intrinsically safe barrier (typically used in opposed-mode applications)	CI2BK-2	Includes CI3RC2 current amplifier, one RS-11 socket, one DIN-rail mount, one dual-channel intrinsically safe barrier

### MAXI-AMP CI3RC2 Current Amplifier Module

Banner MAXI-AMP module model CI3RC2 (part number 36606) is a self-contained module that converts the current output signal of an SMI30 Series sensor to a trip point switch.

Figure 3. Hookup Using Two Single-Channel Barriers

