

NOTES:

1. MATERIALS AND FINISHES:
 BODY, RETAINING RING, CONTACT - BERYLLIUM COPPER, GOLD PLATING
 HOUSING, COVER - BRASS, GOLD PLATING
 INSULATOR - PTFE, NATURAL
 SPACER - ULTEM, NATURAL
2. ELECTRICAL:
 A. IMPEDANCE: 50 OHM
 B. FREQUENCY RANGE: DC-12 GHz
 C. VSWR(RETURN LOSS): 1.10 MAX. @ DC-6 GHz
 1.30 MAX. @ 6-12 GHz
 D. DIELECTRIC WITHSTANDING VOLTAGE: 500 VRMS, MIN.
3. MECHANICAL:
 A. DURABILITY: 100 CYCLES MIN. WHEN MATED WITH FULL DETENT JACK
 500 CYCLES MIN. WHEN MATED WITH LIMITED DETENT JACK
 1000 CYCLES MIN. WHEN MATED WITH SMOOTH BORE JACK
 B. TEMPERATURE RANGE: -65°C TO 165°C
4. PACKAGING:
 A. QUANTITY: SINGLE PACK
 B. MARKING: PACKAGING TO BE MARKED
 "AMPHENOL RF, SMP-FR-C08-3-R & DATE CODE"
5. CABLE ASSEMBLY INSTRUCTIONS:
 A. TRIM CABLE AS SHOWN.
 B. SLIDE FERRULE AND SPACER ONTO CABLE.
 C. INSERT CABLE INTO BODY AND CRIMP BRAID OVER BODY USING .151" HEX.
 D. AFTER CRIMPING, SOLDER CABLE CENTER CONDUCTOR TO CONTACT,
 SOLDER MUST NOT PROTRUDE ABOVE CENTER CONTACT END SURFACE.
 E. PRESS REAR INSULATOR DISC INTO BODY UNTIL IT BOTTOMS.
 F. INSERT CAP UNTIL FLUSH WITH SURFACE OF HOUSING, INSERTION TOOLING
 MUST ENSURE THAT CAP SURFACE IS PARALLEL TO BODY SURFACE.

6 SHOWS CABLE ENTRY DIMENSIONS.

REVISIONS				
REV	DESCRIPTION	DATE	ECN	APPR
A	RELEASE TO MFG.	30-Apr-20	15041	S.HSIEH

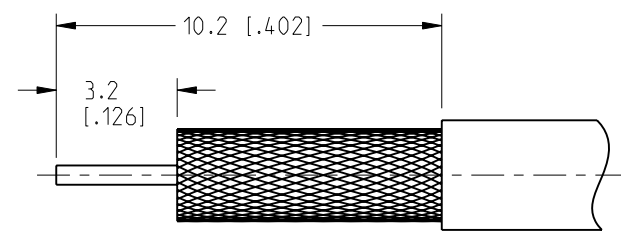
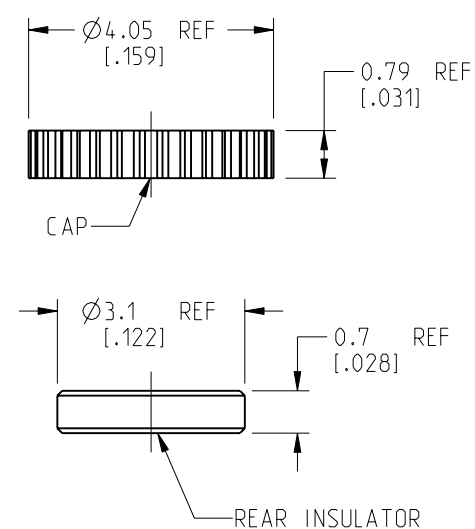
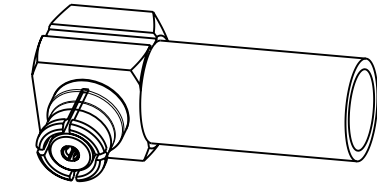

RECOMMENDED CABLE STRIPPING DIMENSIONS

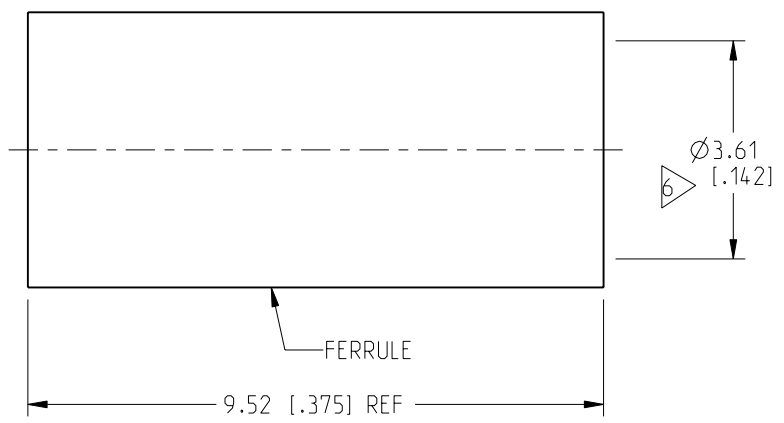
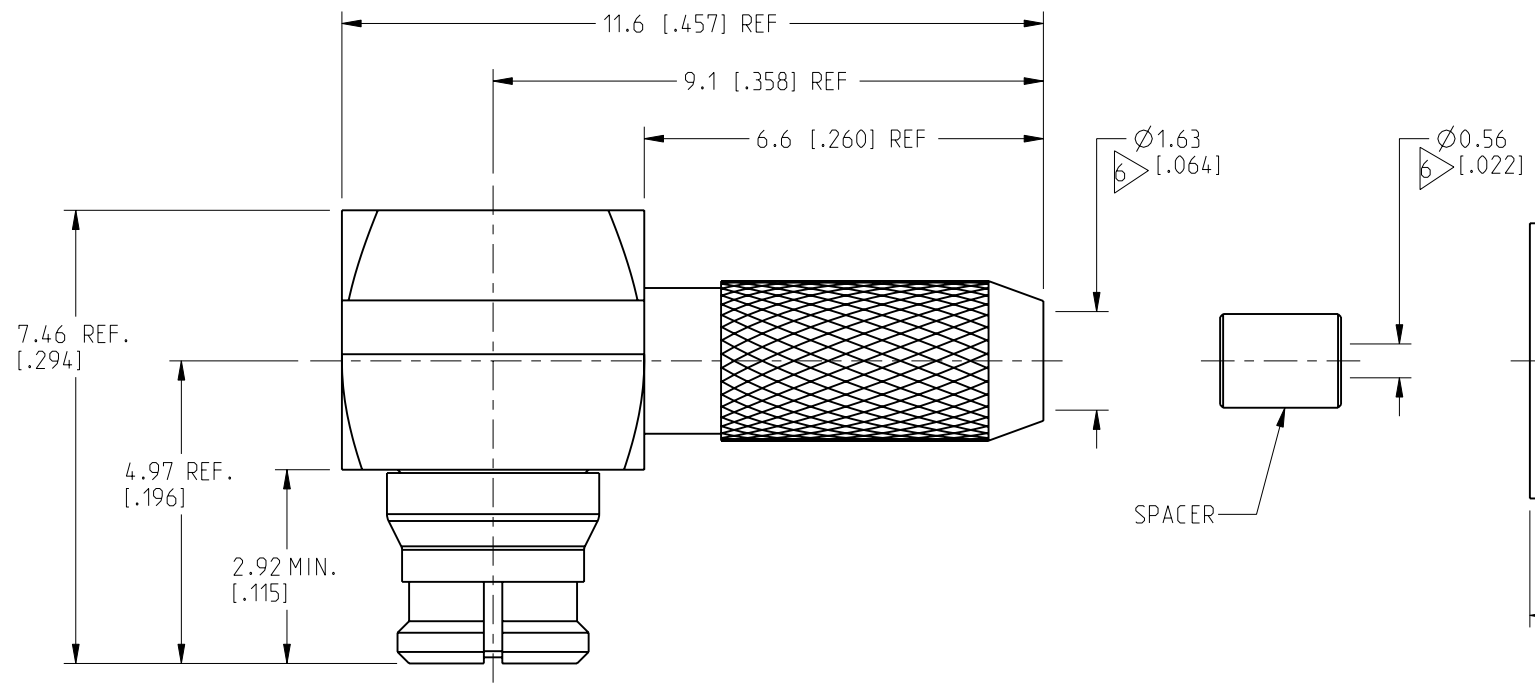
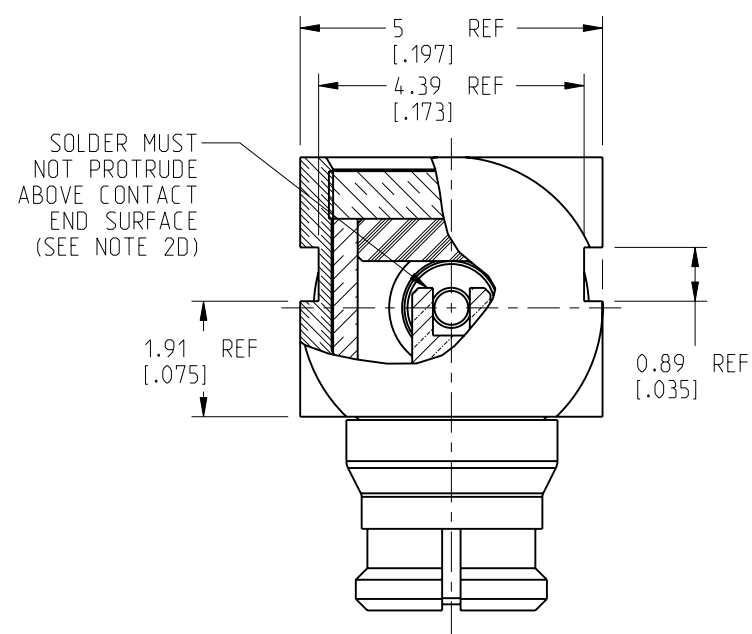

CUSTOMER OUTLINE DRAWING
 ALL OTHER SHEETS ARE FOR INTERNAL USE ONLY

NOTICE: These drawings, specifications, or other data (1) are, and remain the property of Amphenol corp. (2) must be returned upon request; and (3) are confidential and not to be disclosed to any person other than those to whom they are given by Amphenol Corp. The furnishing of these drawings, specifications, or other data by Amphenol Corp., or to any other person to anyone for any purpose is not to be regarded by implication or otherwise in any manner licensing, granting rights to permitting such holder or any other person to manufacture, use or sell any product, process or design, patented or otherwise, that may in any way be related to or disclosed by said drawings, specifications, or other data.		UNLESS OTHERWISE SPECIFIED DIMENSIONS ARE METRIC (INCHES) AND TOLERANCES ARE: <0.5mm = ±0.05mm [± 0.002] >0.5 - 6mm = ±0.1mm [$\pm 0.020 - 0.236 = \pm 0.004$] >6.00 - 30mm = ±0.2mm [$\pm 0.236 - 1.181 = \pm 0.008$] >30.00 - 120mm = ±0.3mm [$\pm 1.181 - 4.725 = \pm 0.012$] ANGLES = ±1°		MATERIAL: SEE NOTE 1 ENGINEER: M.ZHANG DATE: 30-Apr-20		TITLE: SMP R/A PLUG FOR RD-316 CABLE SHEET NO. 2 OF 2 SCALE: 8.0:1.0		Amphenol RF DRAWING NO. SMP-FR-C08-3-R ITEM NO. SMP-FR-C08-3-R PART NO. SMP-FR-C08-3-R		REV: A
THIRD ANGLE PROJ.		REFERENCE: SMP-FR-C08-2 EAR#: 8449								