

Data Sheet

SMS-1508MS-HT-R

PUI Audio's **High-Temp** line of products is designed to meet and exceed the needs of the automotive industry with ultra-wide operating temperatures. The **SMS-1508MS-HT-R** is designed for high output at 800Hz in a small package.

- Wide -40°C to +105°C operating temperature
- 92 dB output at 10cm with 0.8W input
- Wide 400Hz to 10,000 Hz frequency range

### Specifications

Parameters	Values	Units
Rated Input Power	0.8	Watts
Max Input Power	1.0	Watts
Impedance	8±20%	Ohms
Sensitivity @ 1k, 1.6k, 2.0k & 3.2kHz Ave	92±3	dB
Resonant Frequency	800±15%	Hz
Frequency Range	400 ~ 10,000	Hz
Weight	1.7	Grams
Acceptable Soldering Methods	Hand Solder, Reflow	See below for soldering information
Environmental Compliances	RoHS	-
Storage Temperature	-40 ~ +105	°C
Operating Temperature	-40 ~ +105	°C

### Measurement Method (0.8W sine sweep, microphone spaced at 10cm, speaker in 1cc enclosure)

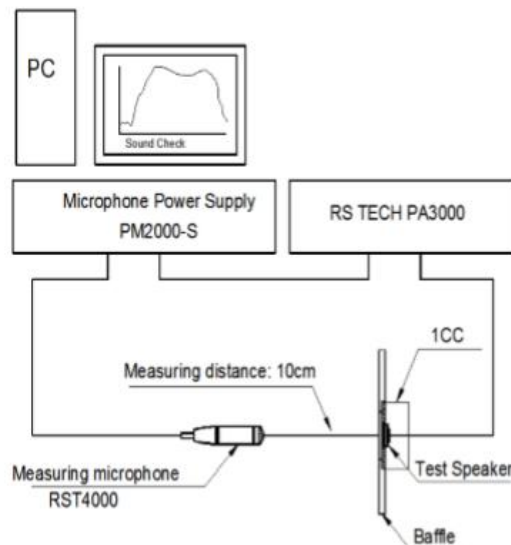

## Typical Frequency Response (0.8W sine-sweep with microphone spaced at 10cm)

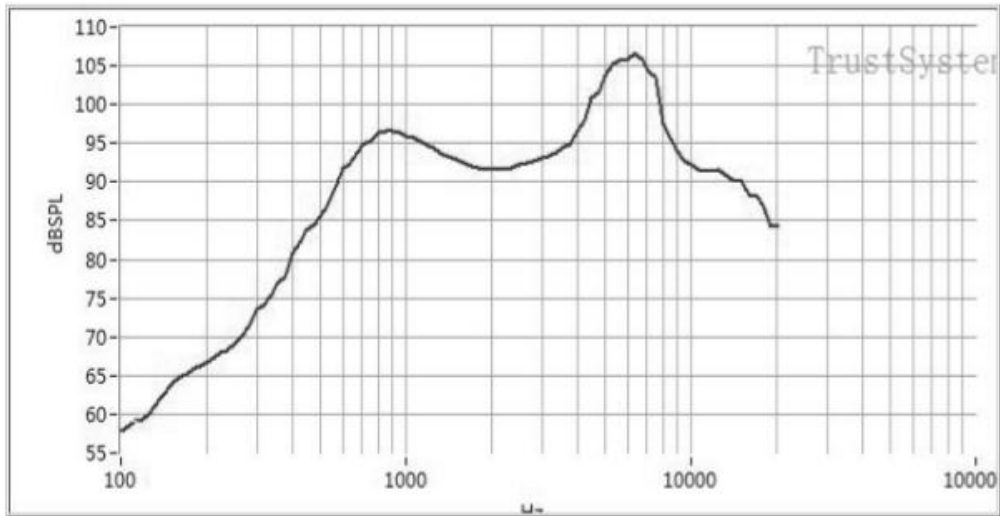

## Recommended Soldering Procedure

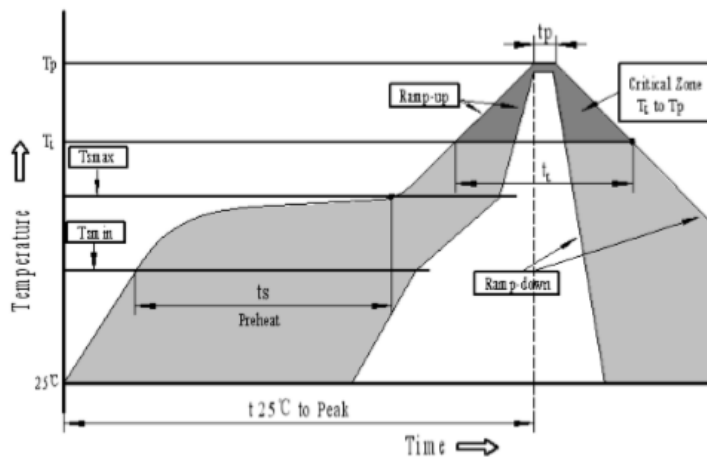

Profile Feature	Pb-Free Assembly
Average ramp-up rate( $T_L$ to $T_p$ )	3°C/second max.
Preheat	
-Temperature Min. ( $T_{smin}$ )	150°C
-Temperature Min. ( $T_{smax}$ )	200°C
-Temperature Min. ( $t_s$ )	60~180 seconds
$T_{smax}$ to $T_L$	
-Ramp-up Rate	3°C/second max.
Time maintained above:	
- Temperature( $T_L$ )	217°C
-Time( $T_L$ )	60~150 seconds
Peak temperature( $T_p$ )	245°C+0/-5°C
Time within 5°C of actual Peak temperature ( $t_p$ )	6 seconds max.
Ramp-down Rate	6°C/second max.
Time 25°C to Peak Temperature	8 minutes max.

## Reliability Testing

Type of Test	Test Specifications
High Temperature Test	Test part at +105°C for 120 hours
Low Temperature Test	Test part at -40°C for 120 hours
Humidity Test	40±2°C, 90 ~ 95% RH, 120 hours
Temperature Cycle Testing	Total 5 cycles, 1 cycle consisting of -40±2°C, 30 minutes 20±5°C 15 minutes 105±2°C, 30 minutes 20±5°C 15 minutes
Vibration Test	The part shall be subjected to a vibration cycle of 10Hz for a period of 1 minute. Total peak amplitude shall be 1.52mm (9.3g). The vibration test shall consist of 2 hours per plane in each three mutually perpendicular planes for a total time of 6 hours.
Shock Test	Sounder shall be measured after being applied a shock of 980m/s <sup>2</sup> for each three mutually perpendicular directions to each of 3 times by a half sine wave.
Drop Test	Drop from 700mm height onto the surface of a 10mm thick wooden board.

**All specifications must be satisfied after the test.**

## Dimensions (Tolerance: ±0.5mm unless otherwise specified)

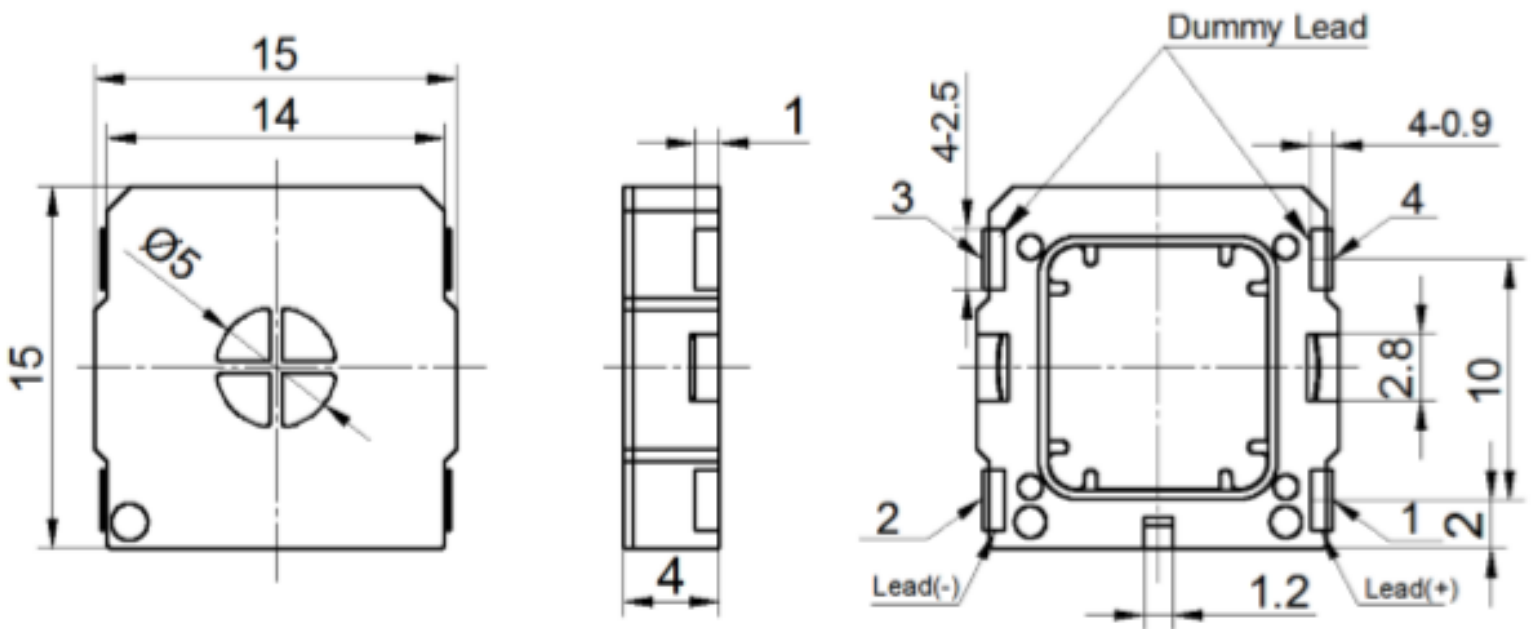



## Packaging (Cont'd)

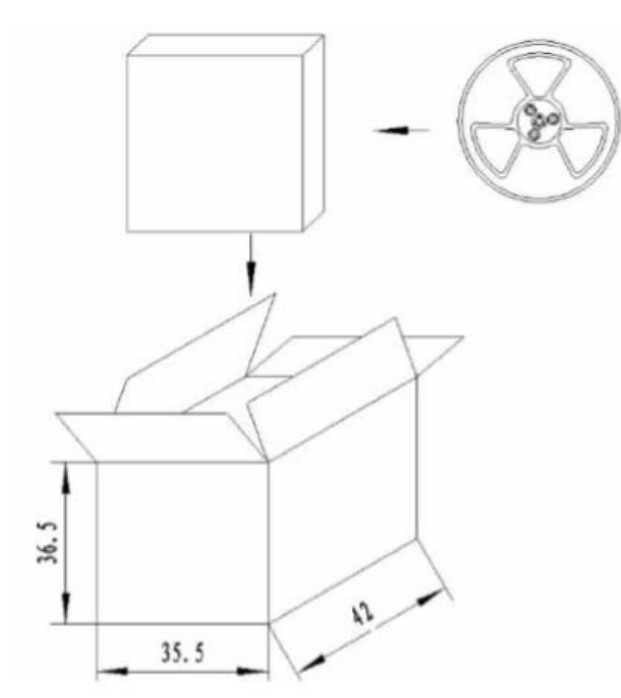

### NOTES:

- 1. 600 PCS per box
- 2. Total 10 boxes per carton
- 3. Total 6000 PCS carton
- 4. Volume:  $42 \times 35.5 \times 36.5$  cm