



Data Sheet	SMT-0440-S-EB-R
------------	-----------------

PUI Audio's 4x4mm **SMT-0440-S-R** features a side-firing sound hole for ultra-tight fitment in space-limited products.

The **SMT-0440-S-EB-R** makes it simple to test, or even integrate, this transducer without spinning-up your own PCB.

Specifications

Parameters	Values	Units
Rated Voltage	3	V0-p
Operating Voltage Range	2~4	V0-p
Current Draw at Rated Voltage*	90	mA
Coil Resistance	17 ±3	Ohms
Minimum SPL @ 10cm*	70	dBa
Resonant Frequency	4,000 ±500	Hz
Housing Material	LCP	-
Terminal Material	Tin-Plated Brass	-
Weight	0.1	Grams
Acceptable Soldering Methods	Hand Solder @ 350C for 5s, Reflow Solder	See page 3 for reflow solder information
Environmental Compliances	RoHS/REACH	-
Operating Temperature	-20 ~ +70	°C
Storage Temperature	-30 ~ +80	°C

*At rated voltage with 50% duty cycle 4 kHz positive biased square-wave

Recommended Drive Circuit (Transistor should have a $V_{ce} \leq 0.15V$ and $h_{FE} \geq 200$)

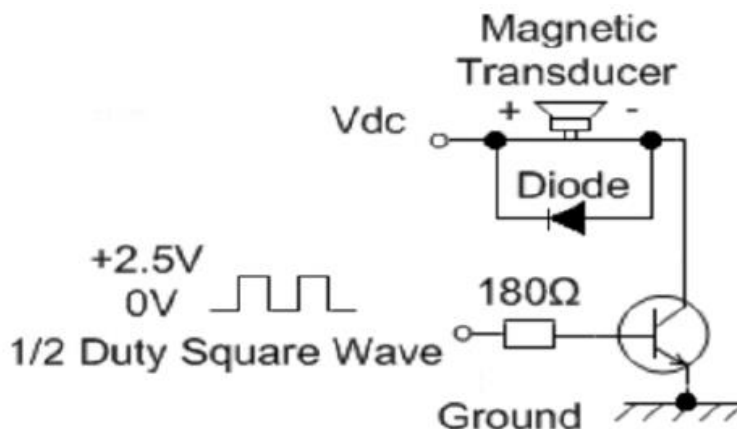

Typical Frequency Response (3V input measured at 10cm)

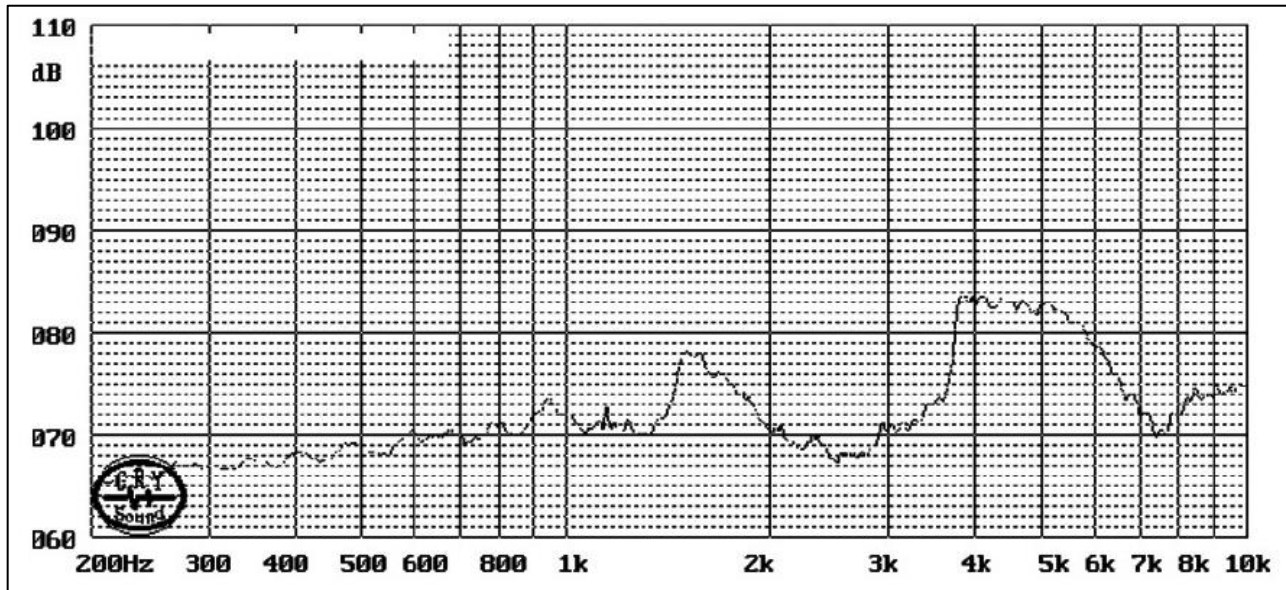

Reliability Testing

Type of Test	Test Specifications
High Temperature Test	The part shall be capable of withstanding a storage temperature is +80°C for 96 hours
Low Temperature Test	The part shall be capable of withstanding a storage temperature is -30°C for 96 hours
Humidity Test	40±2°C, 90~95% RH, 96 hours, then allowed to rest at room temperature for two hours
Temperature Cycle Testing	<p>Total 5 cycles of the following</p>
Vibration Test	<p>The part shall be subjected to a vibration cycle that is 10Hz in a period of 1 minute. Total peak amplitude shall be 1.52mm (9.3g).</p> <p>The vibration test shall consist of 2 hours per plane in each three mutually perpendicular planes for a total time of 6 hours.</p>
Drop Test	Drop from a height of 75cm onto 4 cm thick wood board six times.

After each test, part shall meet specifications with an SPL variance of no more than ±10 dB

Recommended Reflow Soldering Procedure for Transducer

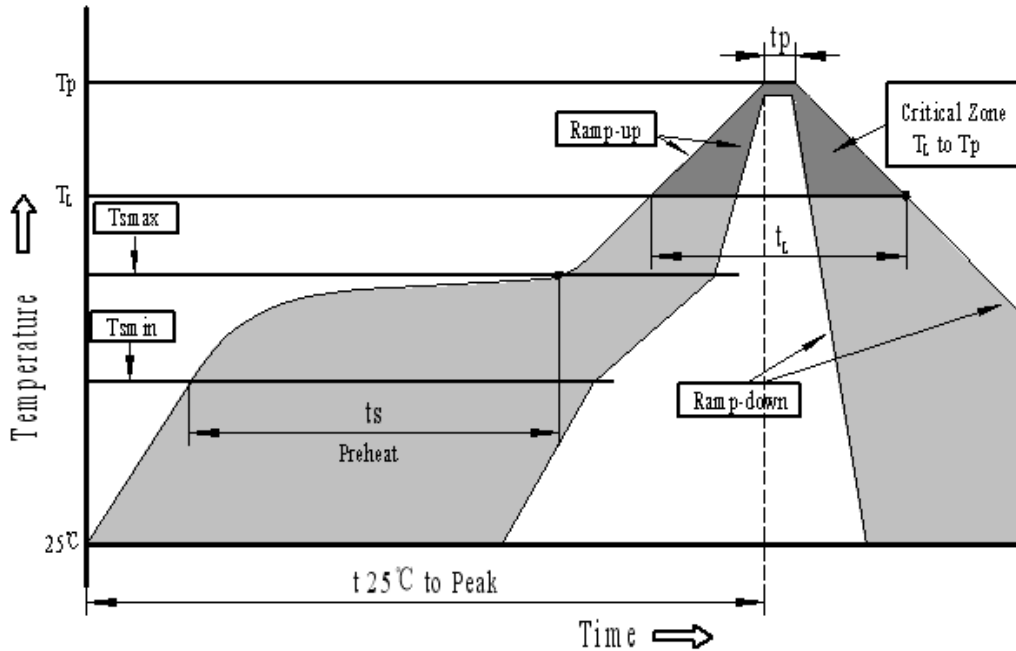

Profile Feature	Pb-Free Assembly
Average ramp-up rate (T_L to T_p)	3°C/second max.
Preheat	
-Temperature Min. (T_{smin})	150°C
-Temperature Min. (T_{smax})	200°C
-Temperature Min. (T_s)	60~180 seconds
T_{smax} to T_L	
-Ramp-up Rate	3°C/second max.
Reflow	
- Temperature (T_L)	217°C
-Time (T_L)	60~150 seconds
Peak temperature (T_p)	250°C+0/-5°C
Time within 5°C of actual Peak temperature (T_p)	6 seconds max.
Ramp-down Rate	6°C/second max.
Time 25°C to Peak Temperature	8 minutes max.

Transducer Dimensions and Suggested Land Pattern*

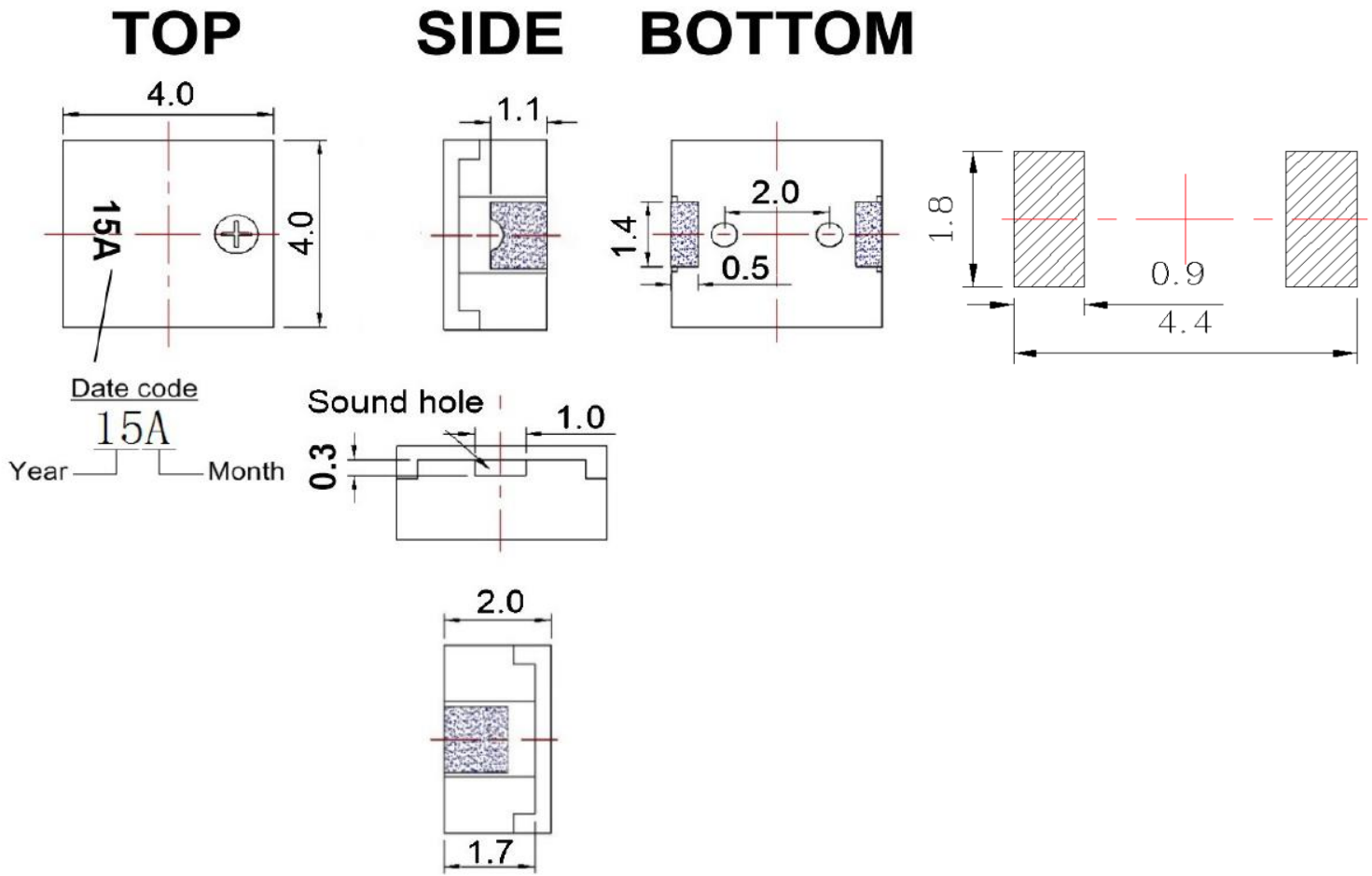

*This land pattern is advisory only and its use or adaptation is entirely voluntary. PUI Audio disclaims all liability of any kind associated with the use, application, or adaptation of this land pattern.

Evaluation Board Dimensions

