

Data Sheet

SMT-0540-T-9-R

Transducer Specifications

Parameters	Values	Units
Rated Voltage	3	V0-p
Operating Voltage Range	2~5	V0-p
Current Draw at Rated Voltage*	≤100	mA
Coil Resistance	12 ±2	Ohms
Minimum SPL @ 10cm*	≥80	dBA
Resonant Frequency	4,000 ±500	Hz
Housing Material	LCP	-
Terminal Material	Tin Plated Brass	-
Weight	0.12	Grams
Acceptable Soldering Methods	Hand Solder, Reflow Solder	See page 3 for soldering information
Environmental Compliances	RoHS/REACH	-
Operating Temperature	-40 ~ +105	°C
Storage Temperature	-40 ~ +120	°C

*At rated voltage with 50% duty cycle 4 kHz positive biased square-wave

Measurement Method (with 3V input)

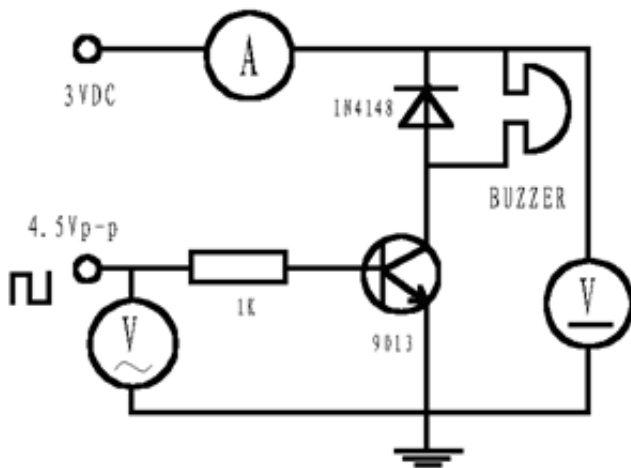

Test Circuit

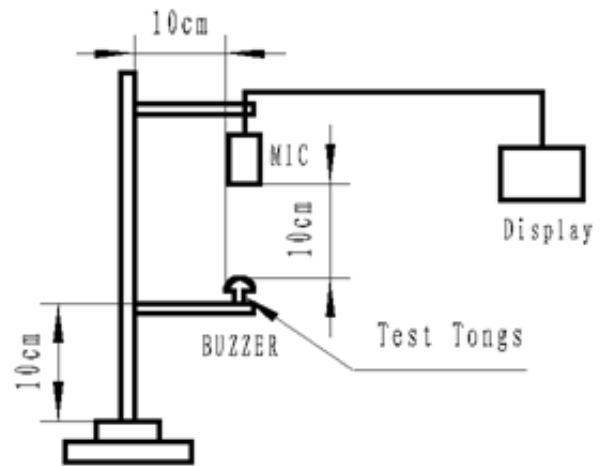

Test Equipis

Typical Frequency Response (3V input measured at 10cm)

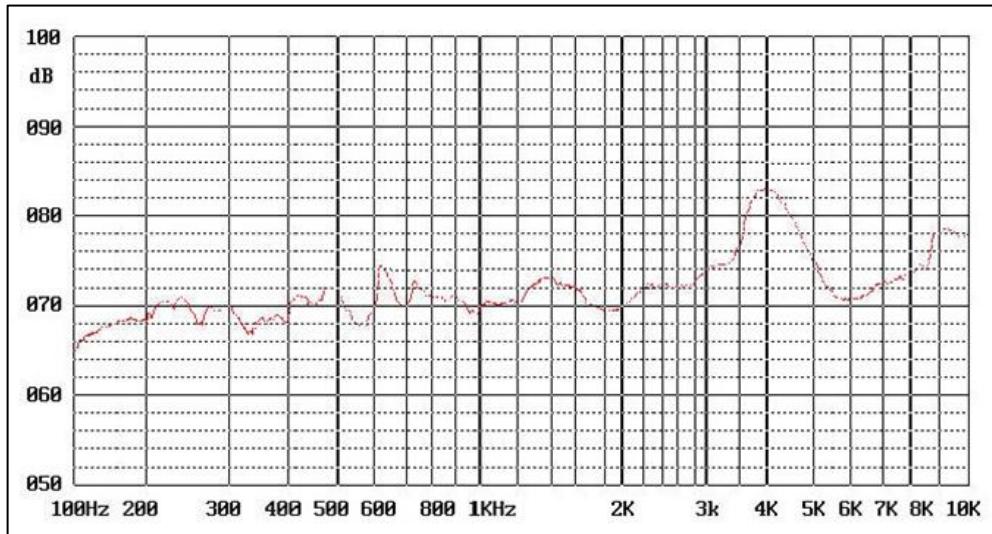

Reliability Testing

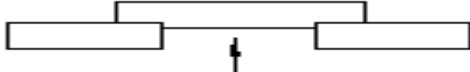
Type of Test	Test Specifications
High Temperature Test	The part shall be capable of withstanding a storage temperature is +120°C for 120 hours
Low Temperature Test	The part shall be capable of withstanding a storage temperature is -40°C for 120 hours
Humidity Test	40±2°C, 90~95% RH, 120 hours
Temperature Cycle Testing	Total 5 cycles, 1 cycle consisting of -40±2°C, 30 minutes 20±5°C, 15 minutes 120±2°C, 30 minutes 20±5°C, 15 minutes
Vibration Test	The part shall be subjected to a vibration cycle that is 10Hz in a period of 1 minute. Total peak amplitude shall be 1.52mm (9.3g). The vibration test shall consist of 2 hours per plane in each three mutually perpendicular planes for a total time of 6 hours.
Drop Test	Mount part to 170g fixture and drop from a height of 150cm onto cement floor for 10 cycles
Terminal Lead Pull Test	The part shall be pulled with a force of 9.8N for 10±1 second, axially, and shall not shows signs of damage. 

After each test, part shall meet specifications with an SPL variance of no more than ±10 dB

Recommended Reflow Soldering Procedure

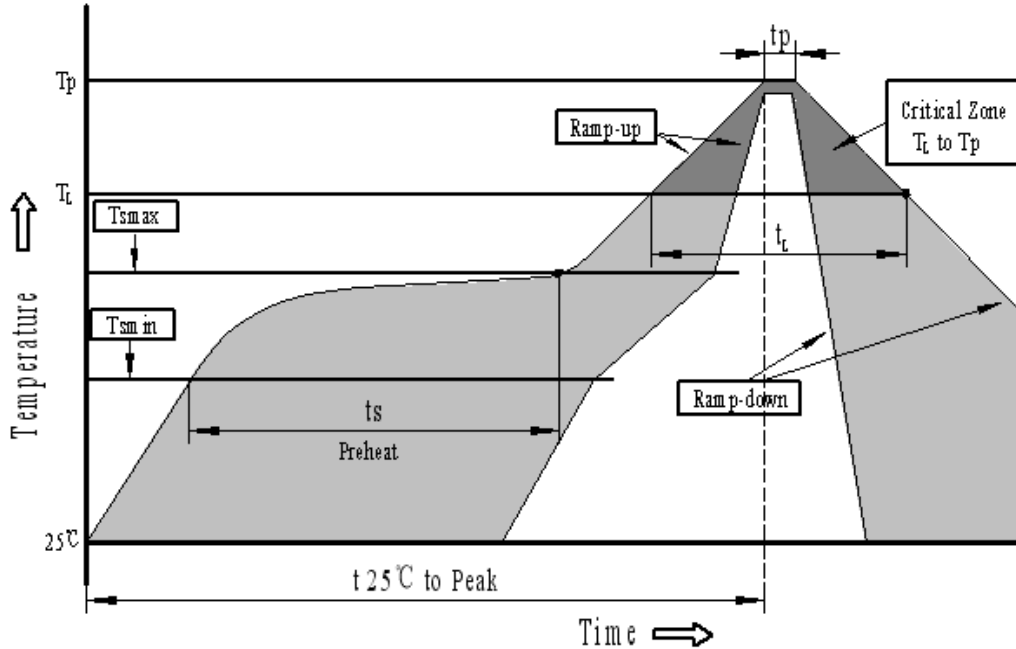

Profile Feature	Pb-Free Assembly
Average ramp-up rate(T_L to T_p)	3°C/second max.
Preheat	
-Temperature Min.(T_{smin})	150°C
-Temperature Min.(T_{smax})	200°C
-Temperature Min.(t_s)	60~180 seconds
T_{smax} to T_L	
-Ramp-up Rate	3°C/second max.
Reflow	
- Temperature(T_L)	217°C
-Time(T_L)	60~150 seconds
Peak temperature(T_p)	250°C+0/-5°C
Time within 5°C of actual Peak temperature (t_p)	6 seconds max.
Ramp-down Rate	6°C/second max.
Time 25°C to Peak Temperature	8 minutes max.

Dimensions and Suggest Land Pattern* (Positive pad is located to the left of the Date Code)

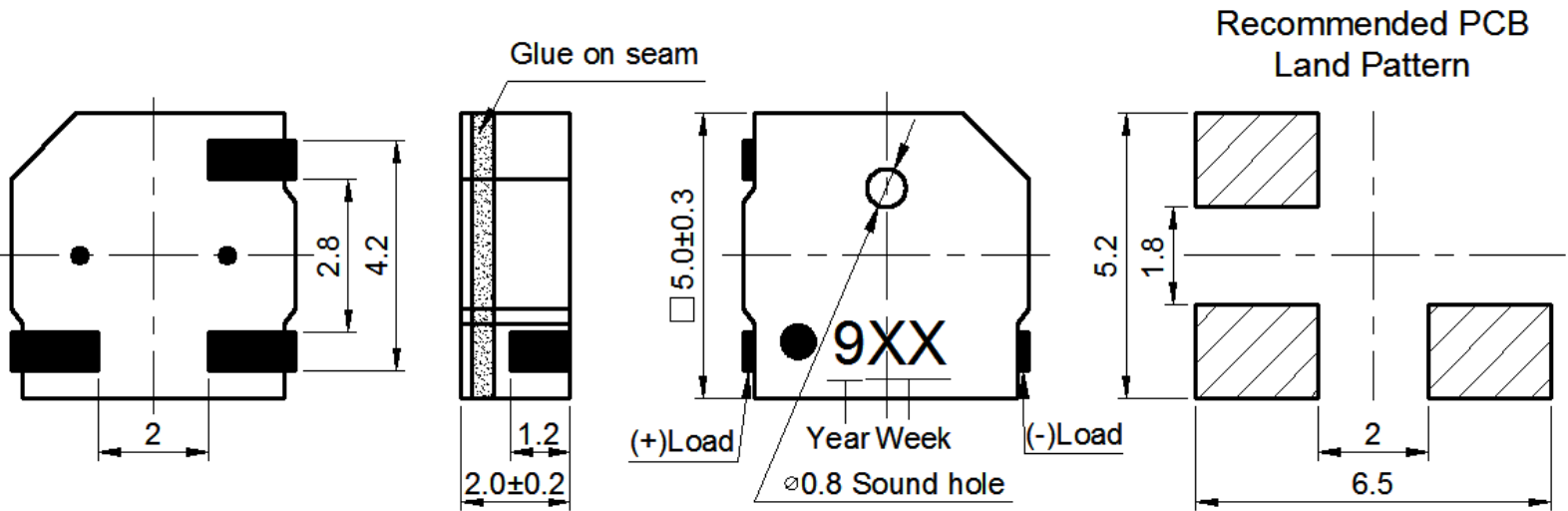

*This land pattern is advisory only and its use or adaptation is entirely voluntary. PUI Audio disclaims all liability of any kind associated with the use, application, or adaptation of this land pattern.

Packaging

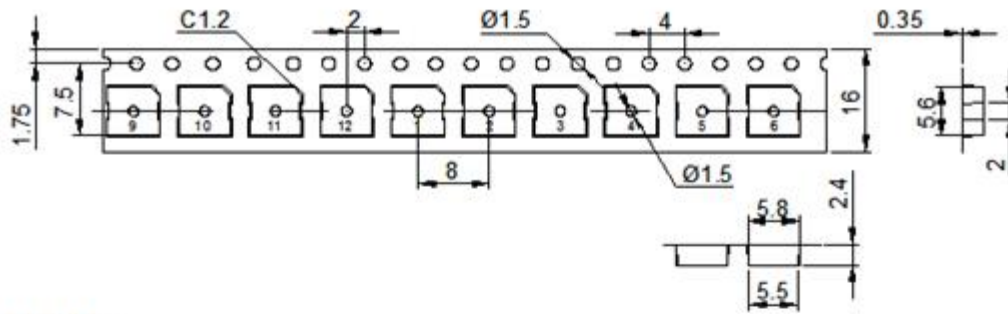

NOTE:

1. 1.10 sprocket hole pitch cumulative tolerance $\pm 0.20\text{mm}$.
2. All dimensions meet EIA-481-D requirements.
3. Thickness: $0.35 \pm 0.05\text{mm}$.
4. Component loaded per 13" reel: 2500pcs.

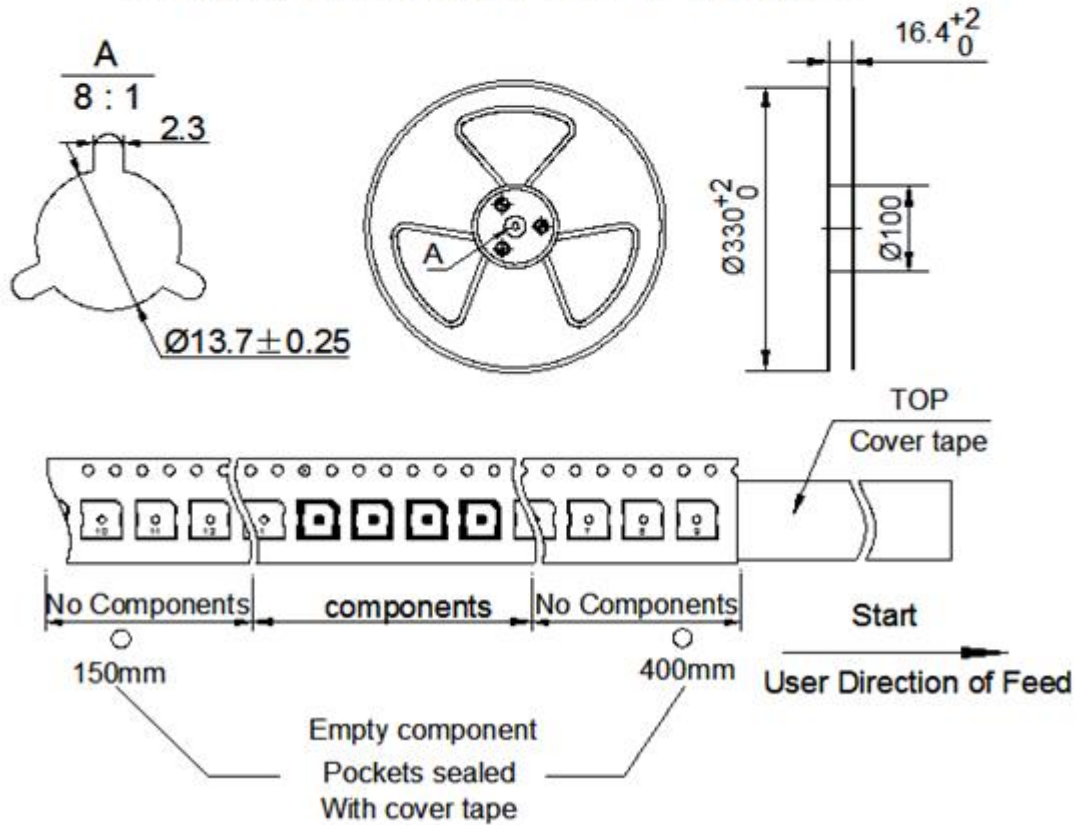

Packaging (cont'd)

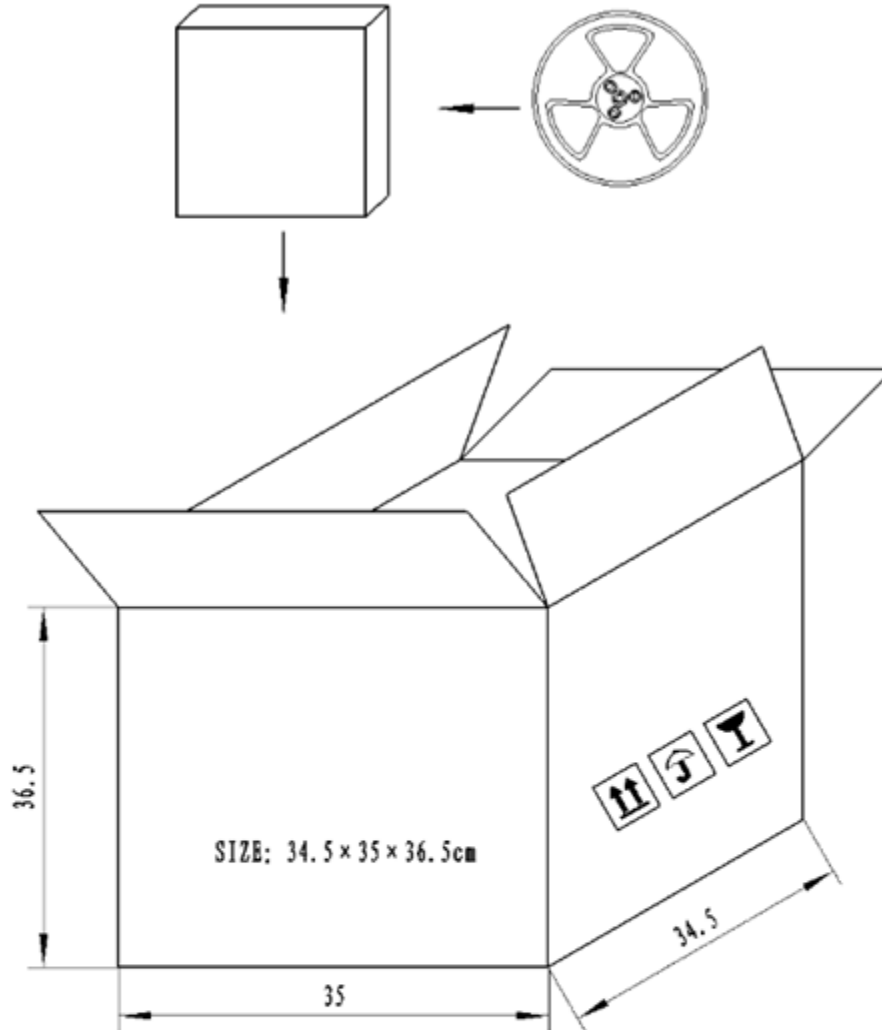

NOTES:

1. 2500 PCS per box
2. 10 boxes / carton 25000 PCS
3. 4 boxes / carton 10000 PCS