



Data Sheet

SMT-0827-S-10-R

### Specifications

Parameters	Values	Units
Rated Voltage	3.6	V
Operating Voltage Range	2.5 ~ 4.5	V
Current Draw at Rated Voltage	45	mA
Coil Resistance	52 ± 3.5	Ohms
Minimum SPL @ 10cm	82	dBA
Resonant Frequency	2,731	Hz
Weight	0.4	Grams
Environmental Compliances	<i>RoHS/REACH</i>	-
Storage Temperature	-40 ~ 85	°C
Operating Temperature	-30 ~ 70	°C

### Measurement Method (Temp: 5 ~ 35 °C; Humidity: 45 ~ 85%; Atmosphere: 860 ~ 1060hPa)

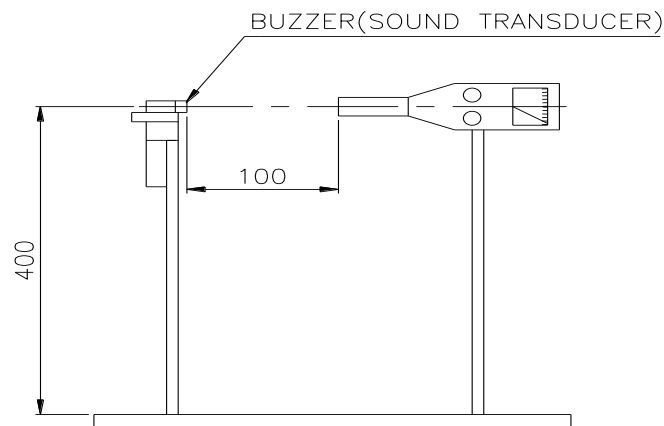

## Typical Frequency Response

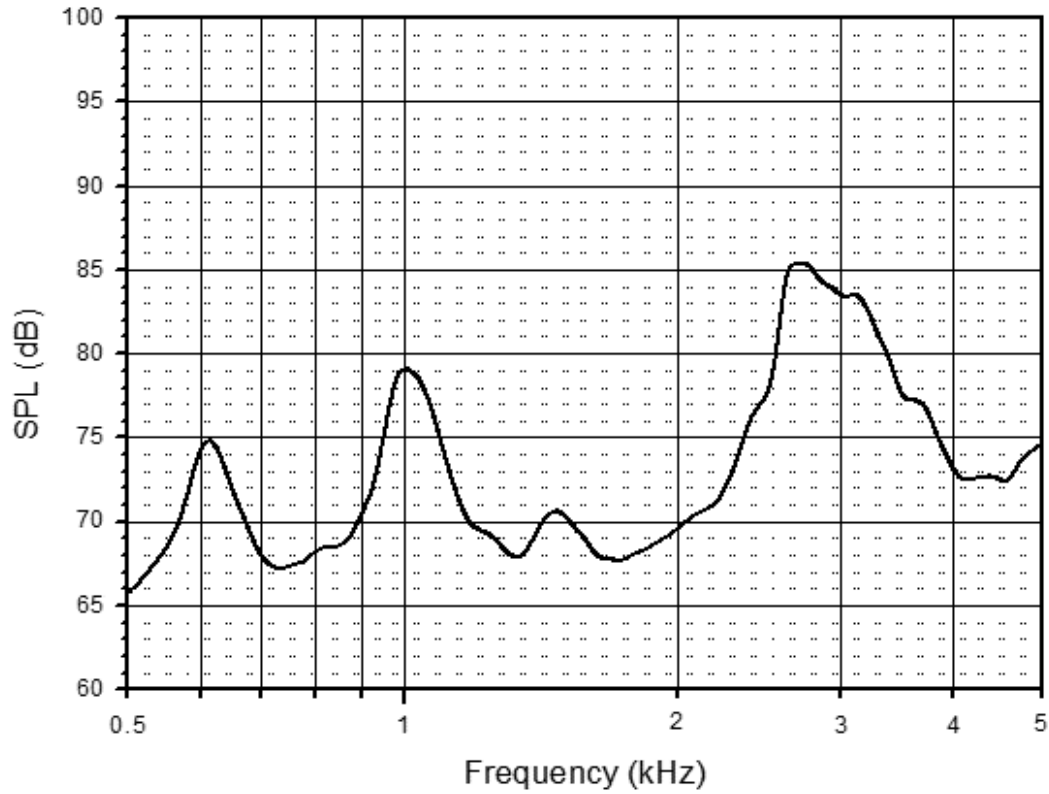

## Recommended Land Pattern

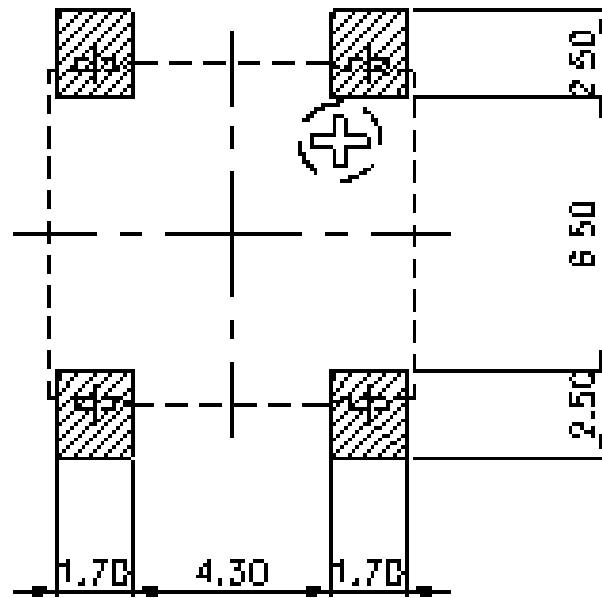

## Reliability Testing

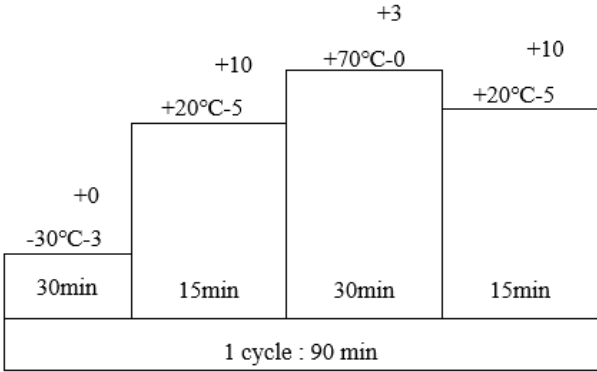
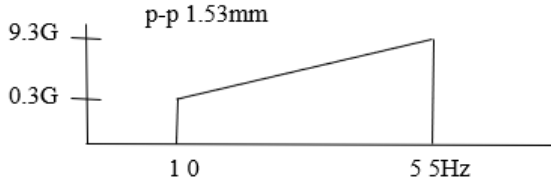
Type of Test	Test Specifications
High Temperature Test	96 hours at 85°C
Low Temperature Test	96 hours at -40°C
Humidity Test	12 hours at 60°C with relative humidity at 95%
Temperature Cycle Testing	<p>Run the test for 5 cycles, with each cycle consisting of:</p>  <p>1 cycle : 90 min</p>
Vibration Test	 <p>Make this test for the directions of X, Y and Z for 2 hours each (total 6 hours).</p>
Drop Test	Fix transducer on PCB with polyester film (t=0.2mm, gross weight: 100g) and the height of 120cm on each of the six surfaces 3 times each.

After reliability test, let rest for 2 hours before testing.

## Dimensions

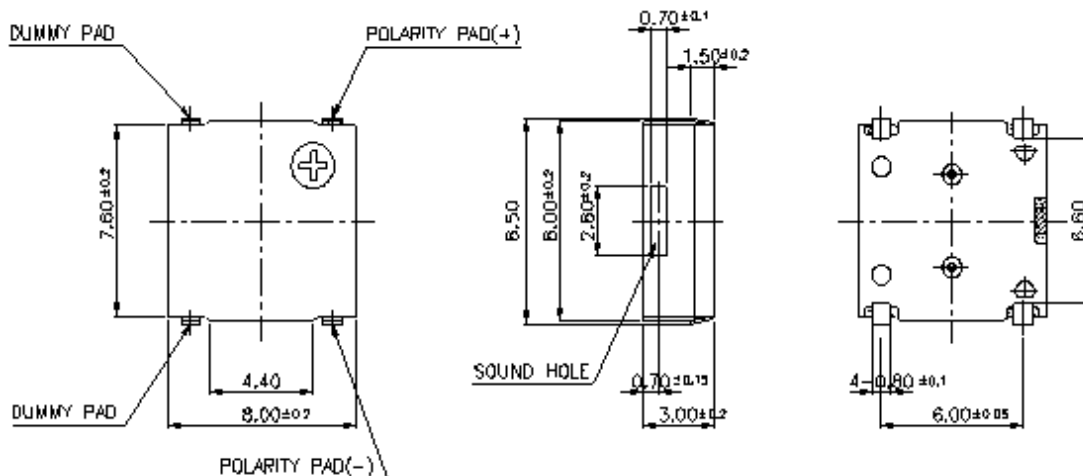

Tolerance:  $\pm 0.2\text{mm}$