

Data Sheet

SMT-0927-S-HT-R

PUI Audio's **High Temperature** line of products is designed to withstand ultra-wide operating temperatures. The **SMT-0927-S-HT-R** is designed for high output at 2700 Hz in a small package.

- Wide -40°C to +105°C operating temperature
- Weighs only 0.4 grams
- ≥95 dB output at 10cm with 3.6 V0-p input

Transducer Specifications

Parameters	Values	Units
Rated Voltage	3.6	V0-p
Operating Voltage Range	2 ~ 5	V0-p
Current Draw at Rated Voltage	≤100	mA
Coil Resistance	16 ± 3	Ohms
Minimum SPL @ 10cm	≥95	dBA
Resonant Frequency	2700 ± 500	Hz
Housing Material	LCP	-
Weight	0.4	Grams
Acceptable Soldering Methods	Hand Solder, Reflow Solder	See page 2 for soldering information
Environmental Compliances	RoHS	-
Storage Temperature	-40 ~ +120	°C
Operating Temperature	-40 ~ + 105	°C

Measurement Method (3.6 V0-p, 2700 Hz, square wave at 50% duty cycle)

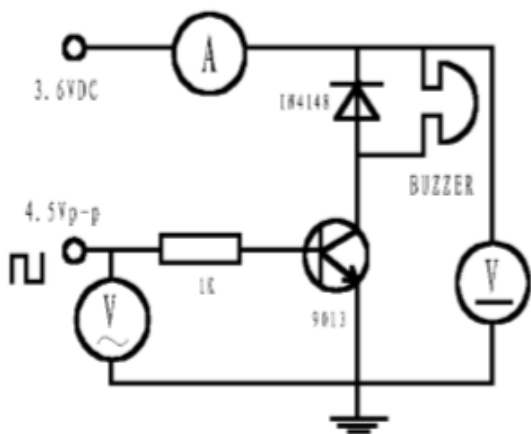

Test Circuit

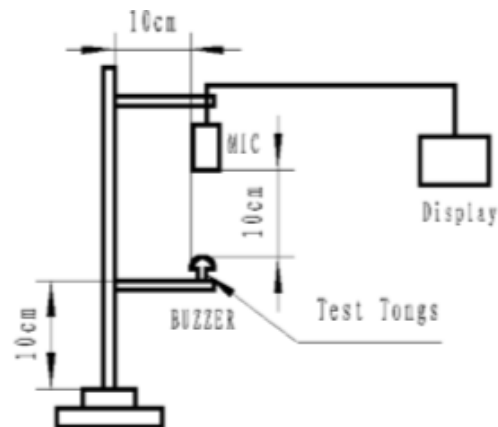

Test Equipis

Typical Frequency Response (3.6 V0-p sine-sweep with microphone spaced at 10cm)

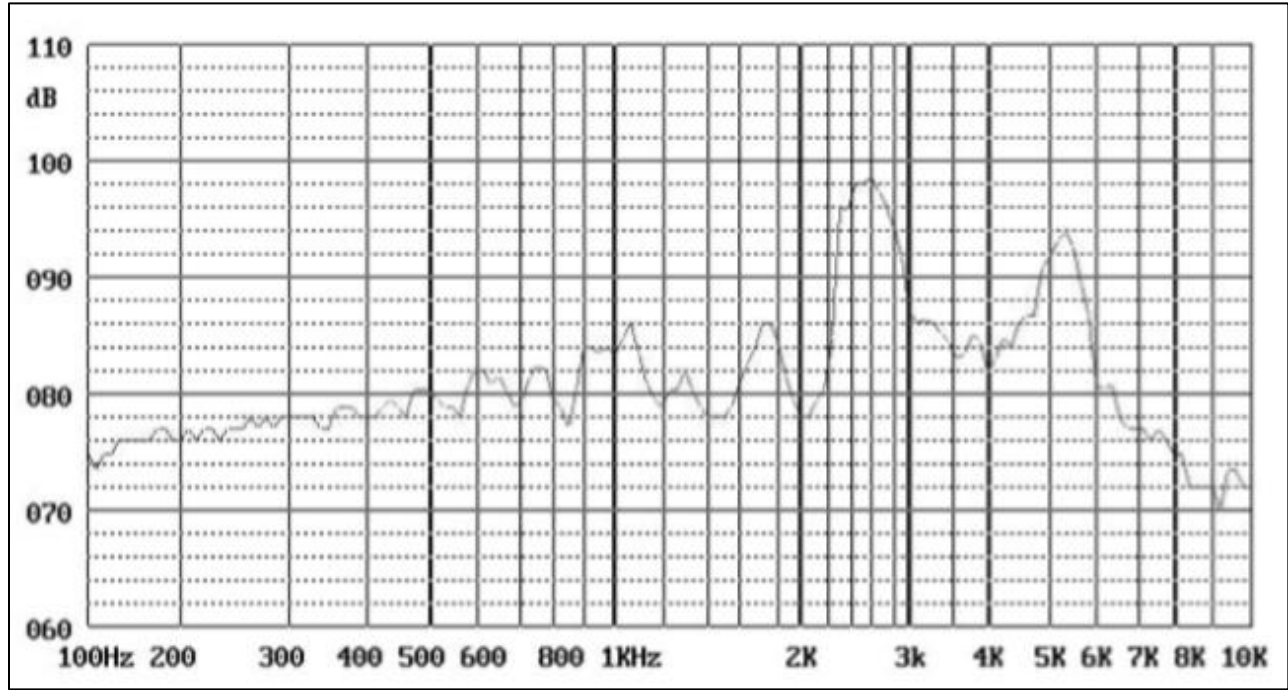

Recommended Soldering Procedure

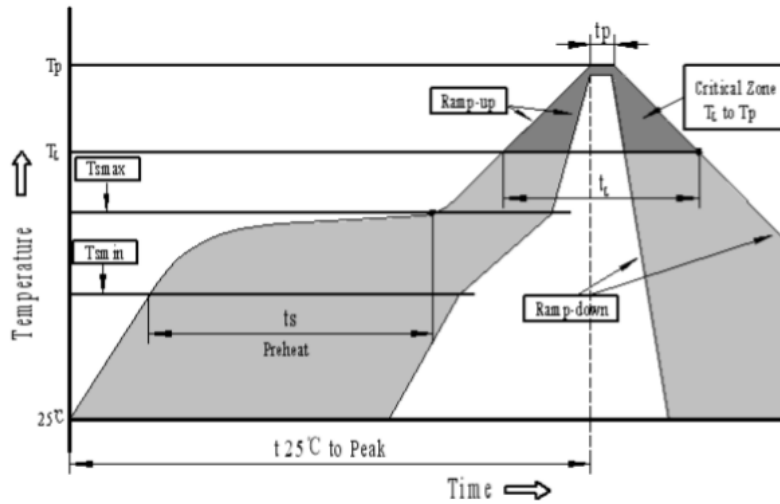

Profile Feature	Pb-Free Assembly
Average ramp-up rate(T_L to T_p)	3°C/second max.
Preheat	
-Temperature Min.(T_{smin})	150°C
-Temperature Min.(T_{smax})	200°C
-Temperature Min.(t_s)	60~180 seconds
T_{smax} to T_L	
-Ramp-up Rate	3°C/second max.
Time maintained above:	
- Temperature(T_L)	217°C
-Time(T_L)	60~150 seconds
Peak temperature(T_p)	250°C+0/-5°C
Time within 5°C of actual Peak temperature (t_p)	6 seconds max.
Ramp-down Rate	6°C/second max.
Time 25°C to Peak Temperature	8 minutes max.

Reliability Testing

Type of Test	Test Specifications
High Temperature Test	Test part at +120°C for 120 hours
Low Temperature Test	Test part at -40°C for 120 hours
Humidity Test	40±2°C, 90~95% RH, 120 hours
Temperature Cycle Testing	Total 5 cycles, 1 cycle consisting of -40±2°C, 30 minutes 20±5°C 15 minutes 120±2°C, 30 minutes 20±5°C 15 minutes
Vibration Test	The part shall be subjected to a vibration cycle is 10Hz in a period of 1 minute. Total peak amplitude shall be 1.52mm (9.3g). The vibration test shall consist of 2 hours per plane in each three mutually perpendicular planes for a total time of 6 hours.
Shock Test	Should be measured after being applied shock (980m/s ²) for each three mutually perpendicular directions to each of 3 times by half of a sine wave.
Drop Test	Drop from 70cm high onto the surface of a 10mm thick wooden board.

After the test the part shall meet specifications without any degradation in appearance and performance except SPL should be within ±10dB of the initial value. (The test should be administered 2 hours after the completion of the experiment.)

Dimensions

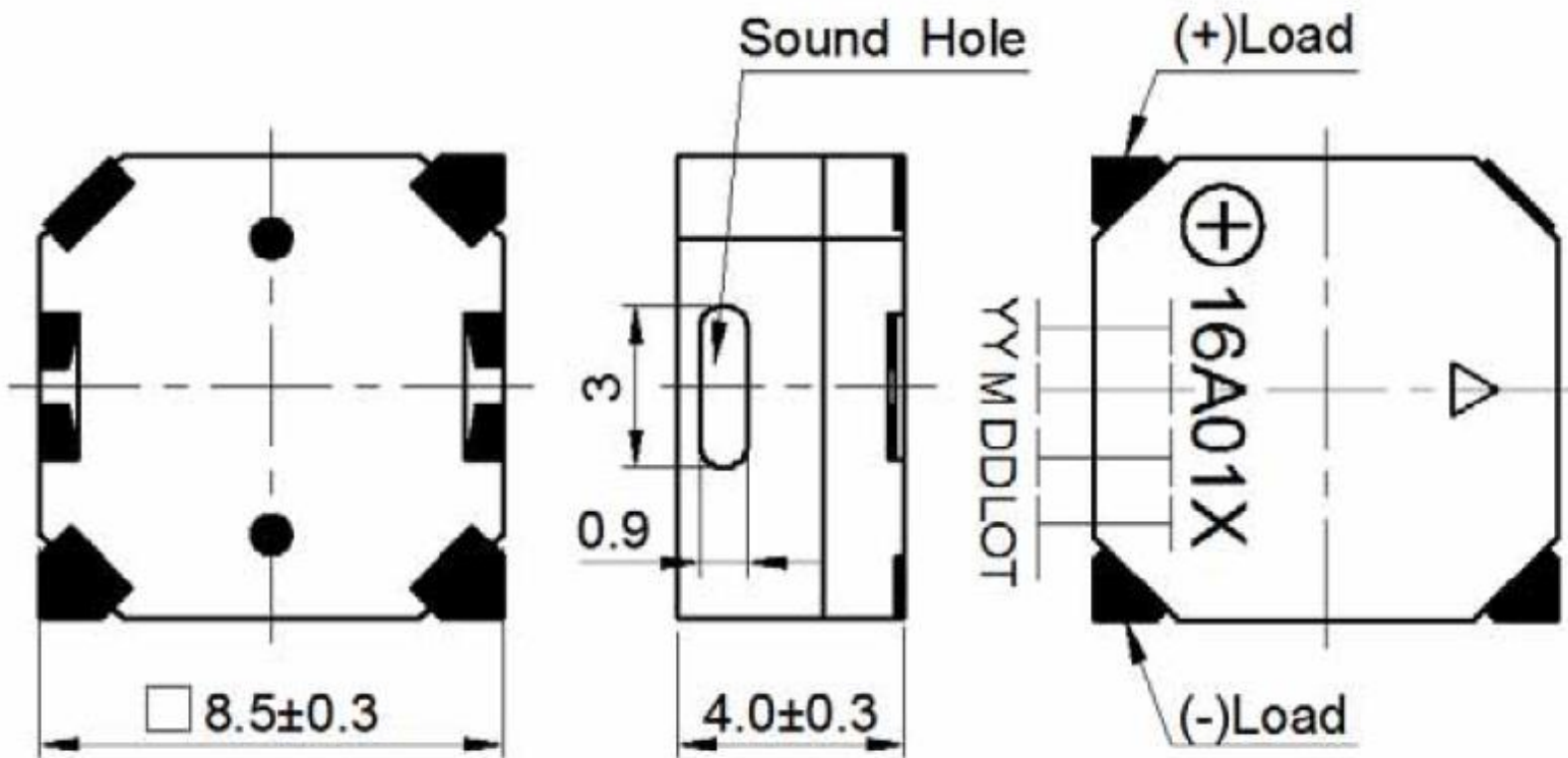

Suggested Land Pattern*

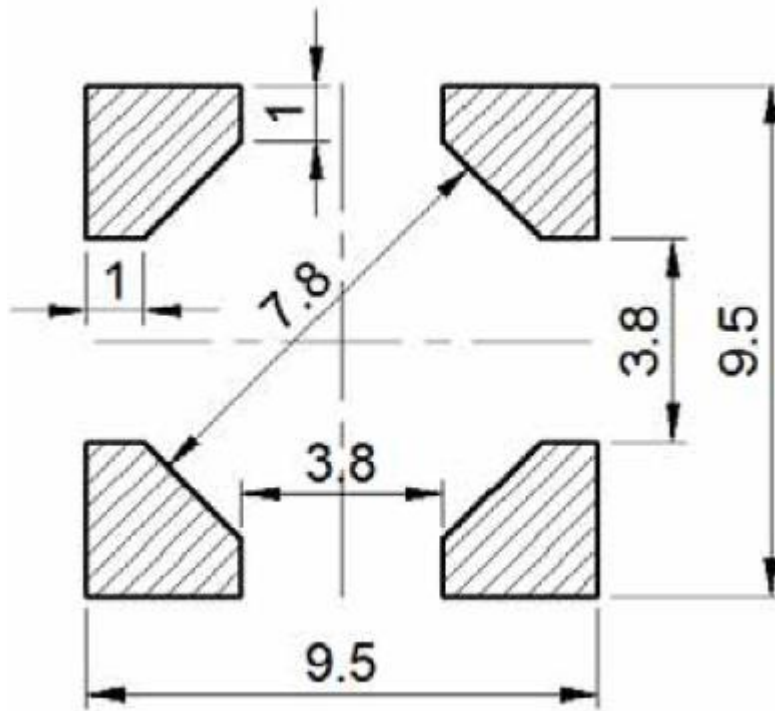

*This land pattern is advisory only and its use or adaptation is entirely voluntary. PUI Audio disclaims all liability of any kind associated with the use, application, or adaptation of this land pattern.

Packaging

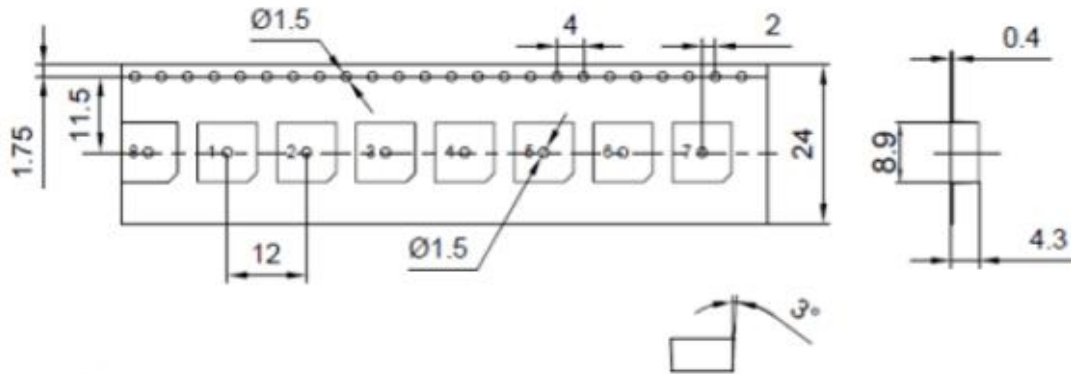

NOTE:

1. 10 sprocket hole pitch cumulative tolerance $\pm 0.20\text{mm}$.
2. All dimensions meet EIA-481-D requirements.
3. Thickness: $0.4 \pm 0.05\text{mm}$.
4. Component loaded per 13" reel: 1000 pcs.

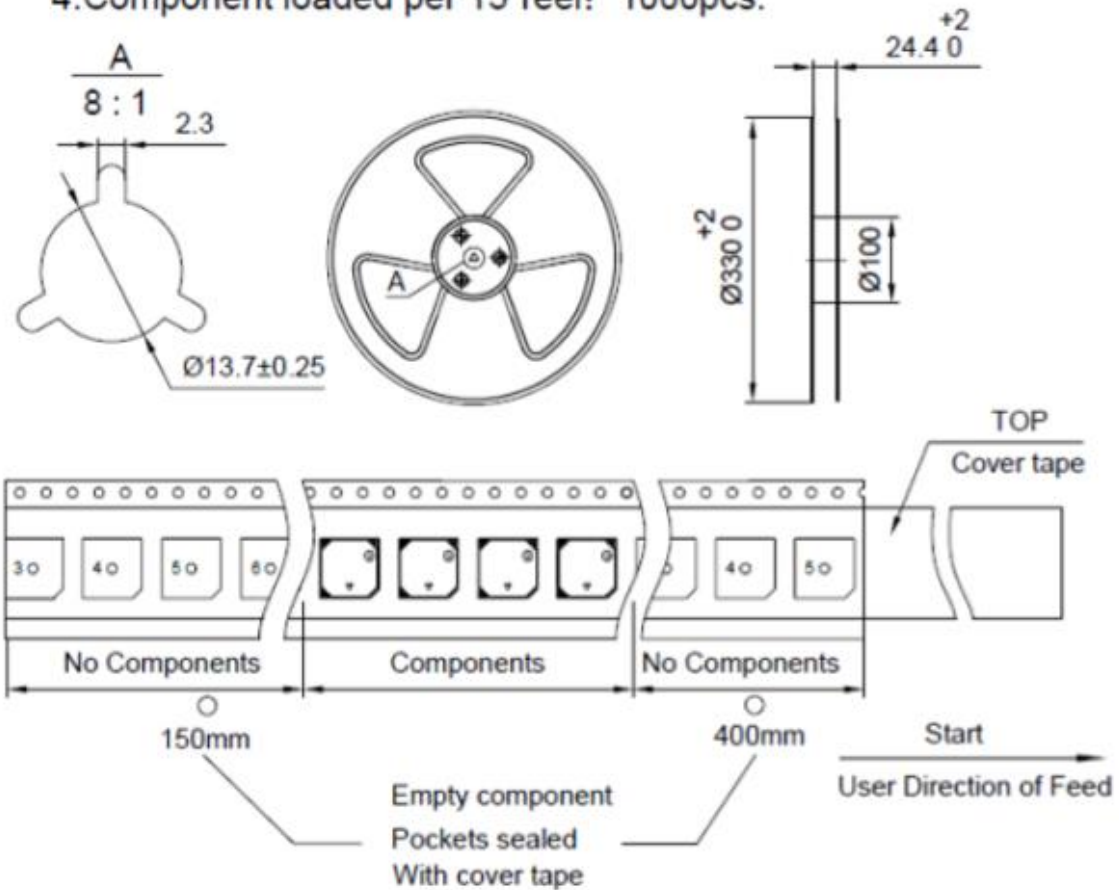

Packaging (Cont'd)

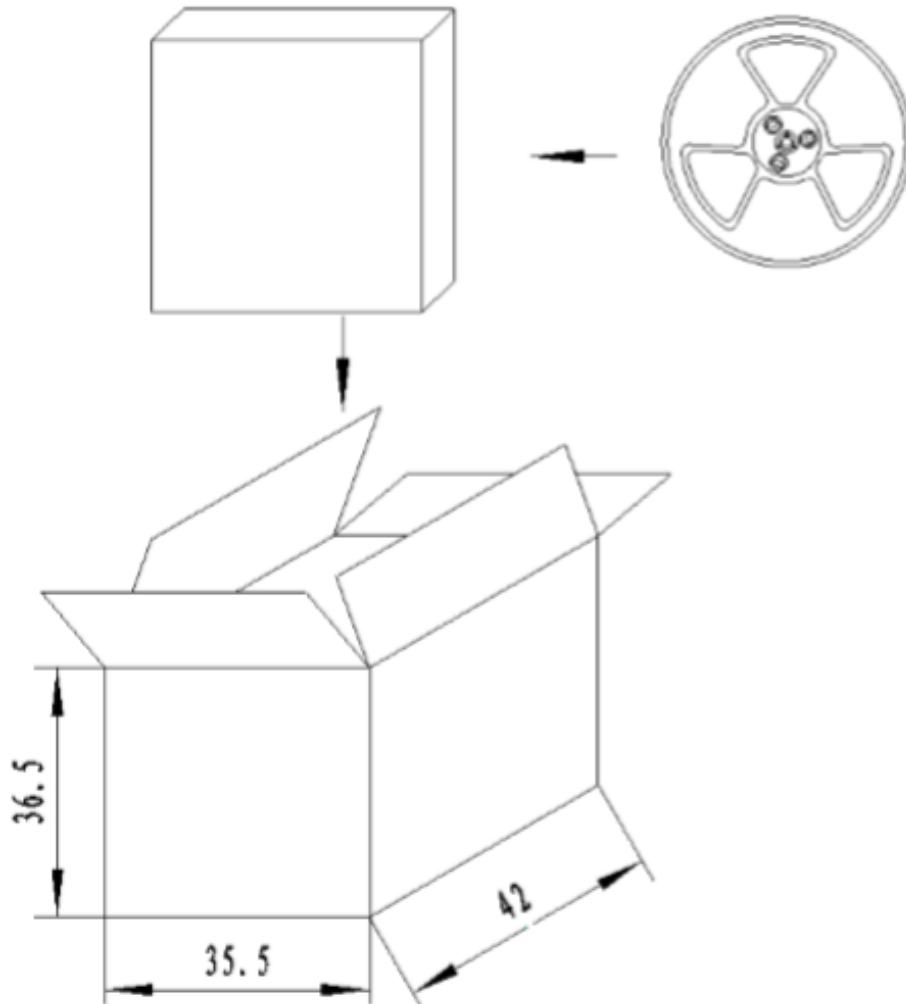

NOTES:

- 1.1000 PCS per box
- 2.Total 10 boxes per carton
- 3.Total 10000 PCS carton