

THIS DOCUMENT CONTAINS DATA PROPRIETARY TO PROJECTS UNLIMITED, INC. ANY USE OR REPRODUCTION, IN ANY FORM, WITHOUT PRIOR WRITTEN PERMISSION OF PROJECTS UNLIMITED, INC. IS PROHIBITED.
© 2005, Projects Unlimited Inc.

SPECIFICATIONS

PARAMETERS	VALUES	UNITS
RATED VOLTAGE	10	Vp-p
OPERATING VOLTAGE RANGE	1 ~ 30	Vp-p
RATED CURRENT (MAX)	7	mA
CAPACITANCE	20,000±30%	pF
MINIMUM SPL @ 10 CM	86	dBA
RESONANT FREQUENCY	3,000±500	Hz
OPERATING TEMPERATURE	-20 ~ +70	°C
STORAGE TEMPERATURE	-30 ~ +80	°C
HOUSING MATERIAL	LCP (WHITE)	-
TERMINAL MATERIAL	Sn PLATED BRASS	-
WEIGHT	4	grams

REVISIONS			
LTR	DESCRIPTION	DATE	APPROVED
-	RELEASED FROM ENGINEERING	11/11/11	
A	REVISED HEIGHT MEASUREMENT	2/1/12	M.L.

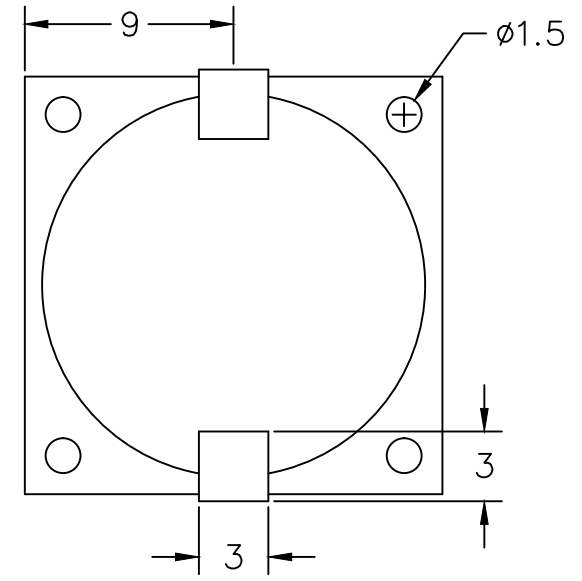
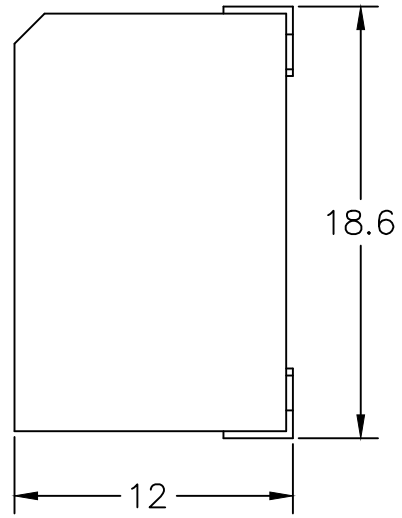
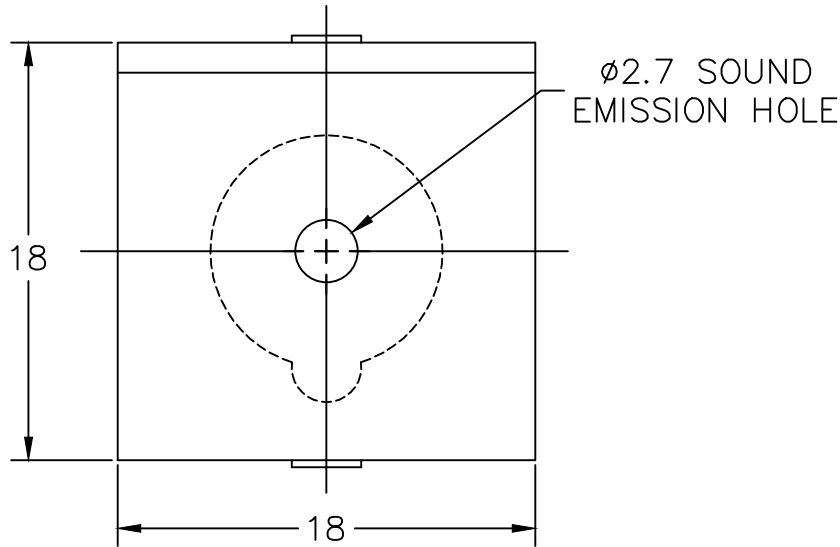

NOTES:

1. ALL DIMENSIONS ARE IN MILLIMETERS.
2. SPECIFICATION SUBJECT TO CHANGE OR WITHDRAWAL WITHOUT NOTICE.
3. THIS PART IS RoHS 2002/95/EC COMPLIANT.

FILE NAME
SMT-1830-TW-2-R.DWG

UNLESS OTHERWISE SPECIFIED: DIMENSIONS ARE IN MILLIMETERS, TOLERANCES ARE ±0.5 AND ANGLES ARE ±3°.		 3541 Stop Eight Road Dayton, Ohio 45414	
APPROVALS	DATE	TRANSDUCER (PIEZO)	
DRAWN J.D.	11/11	SIZE A	DRAWING NO. SMT-1830-TW-2-R
CHECKED M.L.	11/11		
APPROVED B.R.	11/11	SCALE: N.T.S.	SHEET 1 OF 1