

DATA SHEET

SMV1265-040LF: Hyperabrupt Junction Tuning Varactor

Applications

- Wideband RF and microwave VCOs
- Analog phase shifters
- Digital TV tuners

Features

- High tuning ratio
- Low series resistance
- Designed for high-volume, low-cost applications
- Small footprint package (MSL1, 260 °C per JEDEC J-STD-020)



Skyworks Green™ products are compliant with all applicable legislation and are halogen-free. For additional information, refer to *Skyworks Definition of Green™*, document number SQ04-0074.

Description

The SMV1265-040LF hyperabrupt junction tuning varactors is designed for very high capacitance tuning ratios with low series resistance, which makes this device especially attractive for wideband voltage controlled oscillator (VCO) applications.

The packaging and marking information is shown in Table 1. The absolute maximum ratings of the SMV1265-040LF are provided in Table 2. Electrical specifications are specified in Table 3. Figure 1 shows the typical performance of capacitance versus voltage. The SPICE model for the SMV1265-040LF is shown in Figure 2 and the associated model parameters are provided in Table 4. The relationship between voltage and capacitance for the SMV1265-040LF is shown in Table 5.

Table 1. Packaging and Marking

Single
SOD-882 Green™
SMV1265-040LF Marking: HD1
Ls = 0.45 nH



The Pb-free symbol or "LF" in the part number denotes a lead-free, RoHS-compliant package unless otherwise noted as Green™. Tin/lead (Sn/Pb) packaging is not recommended for new designs.

Table 2. SMV1265-040LF Absolute Maximum Ratings (Note 1)

Parameter	Symbol	Minimum	Typical	Maximum	Units
Power dissipation	P _{DIS}			250	mW
Forward current	I _F			20	mA
Operating temperature	T _{OP}	-55		+125	°C
Storage temperature	T _{STG}	-55		+150	°C

Note 1: Exposure to maximum rating conditions for extended periods may reduce device reliability. There is no damage to device with only one parameter set at the limit and all other parameters set at or below their nominal value. Exceeding any of the limits listed here may result in permanent damage to the device.

CAUTION: Although this device is designed to be as robust as possible, electrostatic discharge (ESD) can damage this device. These devices must be protected at all times from ESD. Static charges may easily produce potentials of several kilovolts on the human body or equipment, which can discharge without detection. Industry-standard ESD precautions should be used at all times.

Table 3. SMV1265-040LF Electrical Specifications (Note 1)
(T_{OP} = 25 °C, Unless Otherwise Noted)

Parameter	Symbol	Test Condition	Min	Typical	Max	Units
Reverse leakage current	I _R	V _R = 26 V			20	nA
Reverse breakdown voltage	V _{BR}	I _R = 10 μA	28			V
Capacitance	C _{T1}	V _R = 1 V, f = 1 MHz	12.5	13.8	14.7	pF
	C _{T26}	V _R = 26 V, f = 1 MHz	0.58	0.70	0.83	pF
Capacitance ratio	C _{T1} /C _{T26}	C _T (1 V)/C _T (26 V)	17.7	19.5		–
Series resistance	R _S	V _R = 1 V, f = 470 MHz		2.4		Ω

Note 1: Performance is guaranteed only under the conditions listed in this table.

Typical Performance Characteristics

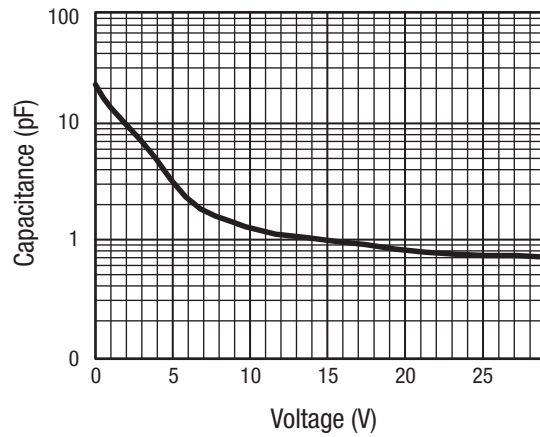

Figure 1. Capacitance vs Voltage @ 25 °C

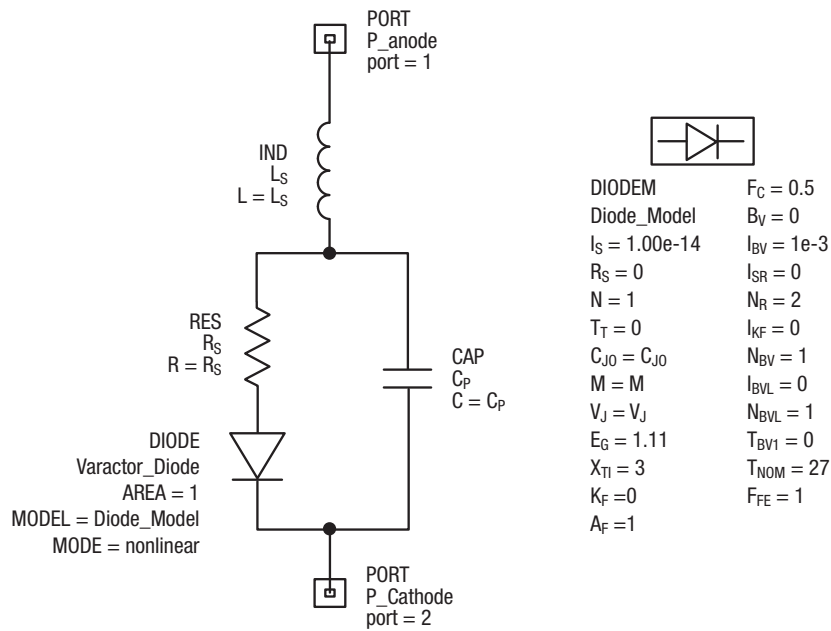

Figure 2. SPICE Model

Table 4. SPICE Model Parameters

Part Number	C _{J0} (pF)	V _J (V)	M	C _P (pF)	R _S (Ω)	L _S (nH)
SMV1265-040LF	22.5	30	13	0.71	2.4	0.45

Table 5. SMV1265-040LF Voltage vs Capacitance

Voltage (V _R) (V)	Typical Capacitance (C _T) (pF)
0	22.47
0.5	17.41
1.0	14.26
2.0	10.23
3.0	7.40
4.0	5.15
5.0	3.38
6.0	2.37
7.0	1.86
8.0	1.61
9.0	1.45
10	1.30
12	1.12
14	1.05
16	0.97
18	0.91
20	0.83
22	0.78
24	0.75
26	0.73
28	0.73
30	0.71

Package and Handling Information

The package dimensions and tape and reel dimensions are shown in Figure 3 and 4, respectively.

Instructions on the shipping container label regarding exposure to moisture after the container seal is broken must be followed. Otherwise, problems related to moisture absorption may occur when the part is subjected to high temperature during solder assembly.

The SMV1265-040LF is rated to Moisture Sensitivity Level 1 (MSL1) at 260 °C. They can be used for lead or lead-free

soldering. For additional information, refer to the Skyworks Application Note, *Solder Reflow Information*, document number 200164.

Care must be taken when attaching this product, whether it is done manually or in a production solder reflow environment. Production quantities of this product are shipped in a standard tape and reel format.

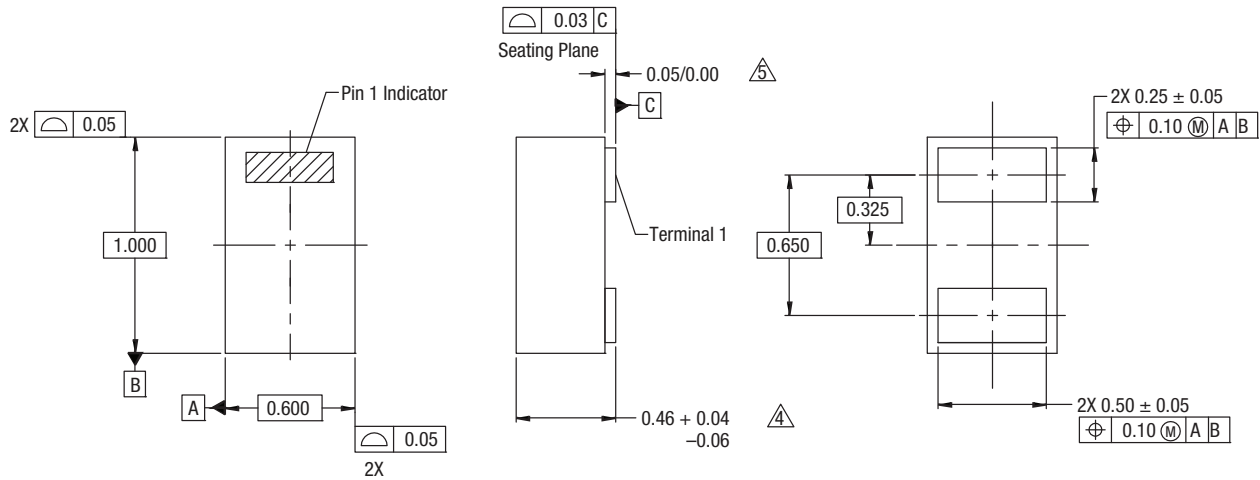

- NOTES:
1. All measurements are in millimeters.
 2. Dimensions and tolerances according to ASME Y14.5M-1994.
 3. These packages are used principally for discrete devices.
 4. This dimension includes stand-off height and package body thickness, but does not include attached features, e.g., external heatsink or chip capacitors. An integral heatslug is not considered an attached feature.
 5. This dimension is primarily terminal plating, but does not include small metal protrusion.

Y1410

Figure 3. SOD-882 Package Dimensions

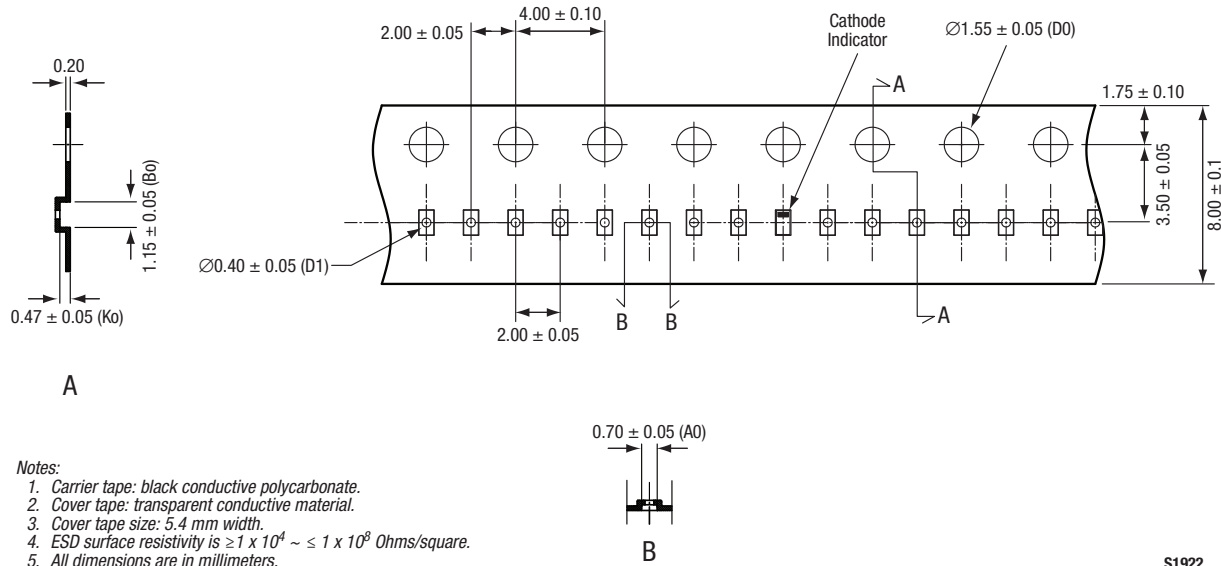

- Notes:
1. Carrier tape: black conductive polycarbonate.
 2. Cover tape: transparent conductive material.
 3. Cover tape size: 5.4 mm width.
 4. ESD surface resistivity is $\geq 1 \times 10^4 \sim \leq 1 \times 10^8$ Ohms/square.
 5. All dimensions are in millimeters.

S1922

Figure 4. SOD-882 Tape and Reel Dimensions