

### Features

- Low Series Resistance
- Low Capacitance
- Wide Dynamic Range
- Silicon Nitride / Glass Passivation
- SOT23 Surface Mount Package
- RoHS\* Compliant

### Description

These PIN diodes are specifically designed for commercial applications requiring devices in the SOT-23 surface mount package. The series in low profile has options for bulk or tape and reel. This series offers a wide range of specifications and package configurations to give the designer wide flexibility.

Typical applications of these PIN diodes are switches, phase shifters, pulse and amplitude modulators, limiters, leveling circuits and attenuators.

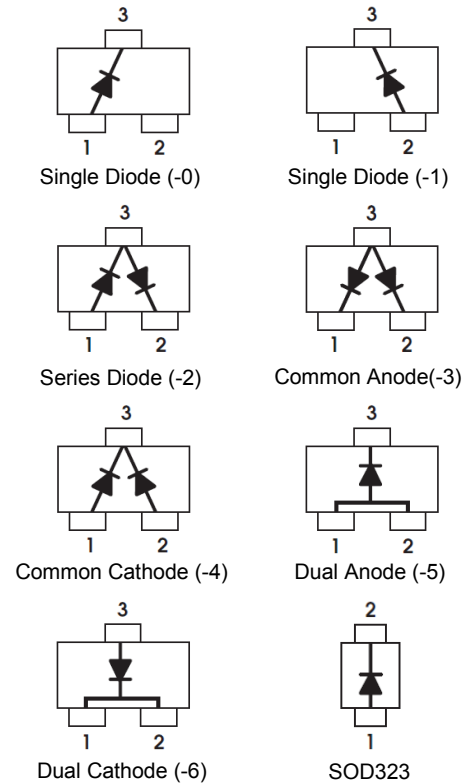

### Electrical Specifications: @ +25°C

Part Number	ID Code <sup>1</sup>	Total Capacitance $C_T$	Voltage Breakdown $V_B$	Series Resistance $R_S$		Carrier Lifetime $T_L$
		1 MHz	$I_R = 10 \mu A$	100 mA, 100 MHz	10 mA, 100 MHz	$I_F = 10 mA, I_R = 6 mA$
		pF	V	$\Omega$		ns
		Typical	Minimum	Typical		Typical

#### PIN Attenuator Diodes

SMPN7453-SOT23-	0S	0.35 @ 50 V	200	0.80	2.5	2500
	1S	0.35 @ 50 V				
	2ST	0.45 @ 50 V				
	3CA	0.45 @ 50 V				
	4CC	0.45 @ 50 V				
SMPN7380-SOT23-	0S	0.35 @ 50 V	200	1.0	3.0	1500
	1S	0.35 @ 50 V				
	2ST	0.45 @ 50 V				
	3CA	0.45 @ 50 V				
	4CC	0.45 @ 50 V				

(Continued next page)

<sup>1</sup> \* Restrictions on Hazardous Substances, European Union Directive 2011/65/EU.

## PIN Switching Diode

Rev. V1

### Electrical Specifications: @ +25°C

Part Number	ID Code <sup>1</sup>	Total Capacitance $C_T$	Voltage Breakdown $V_B$	Series Resistance $R_S$		Carrier Lifetime $T_L$
		1 MHz	$I_R = 10 \mu A$	100 mA, 100 MHz	10 mA, 100 MHz	$I_F = 10 \text{ mA},$ $I_R = 6 \text{ mA}$
		pF	V	$\Omega$		ns
		Typical	Minimum	Typical		Typical
<b>PIN Switching Diodes</b>						
SMPN7310-SOT23-	0S	0.30 @ 5 V	100	0.60	1.0	120
	1S	0.30 @ 5 V				
	2ST	0.40 @ 5 V				
	3CA	0.40 @ 5 V				
	4CC	0.40 @ 5 V				
SMPN7316-SOT 23-	0S	0.30 @ 5 V	100	0.60	1.0	200
	1S	0.30 @ 5 V				
	2ST	0.40 @ 5 V				
	3CA	0.40 @ 5 V				
	4CC	0.40 @ 5 V				
<b>PIN General Purpose Diodes</b>						
SMPN7335-SOT 23-	0S	0.30 @ 50 V	200	1.50	2.0	500
	1S	0.30 @ 50 V				
	2ST	0.40 @ 50 V				
	3CA	0.40 @ 50 V				
	4CC	0.40 @ 50 V				
<b>PIN Low Capacitance for High Frequency Applications</b>						
SMPN7320-SOT23-	0S	0.20 @ 10 V	100	2.0	4.0	170
	1S	0.20 @ 10 V				
	2ST	0.30 @ 10 V				
	3CA	0.30 @ 10 V				
	4CC	0.30 @ 10 V				

1. 0,1,S=Single; 2,ST=Series Tee; 3,CA=Common Anode; 4,CC=Common Cathode Also available in SOD323 package.

### Absolute Maximum Ratings

Parameter	Absolute Maximum
Forward Current	1 A, 1 $\mu s$ pulse
Peak Inverse Voltage	Same as $V_{BR}$
Power Dissipation	250 mW, derate linearly to 0 @ 150°C
Operating / Storage Temperature	-65°C to +150°C

2

MACOM Technology Solutions Inc. (MACOM) and its affiliates reserve the right to make changes to the product(s) or information contained herein without notice. Visit [www.macom.com](http://www.macom.com) for additional data sheets and product information.

For further information and support please visit:  
<https://www.macom.com/support>

### Typical Resistance Curves @ 100 MHz

**SMPN7335**

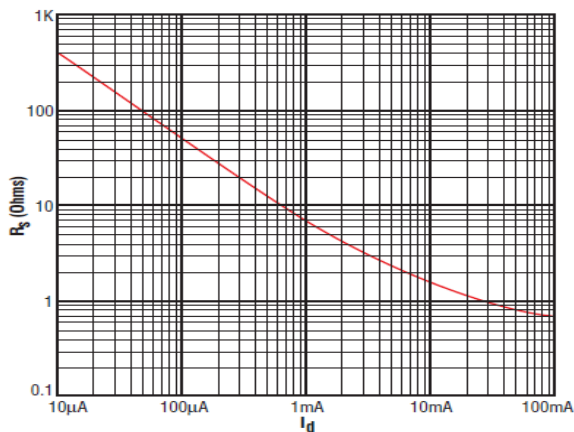

**SMPN7453**

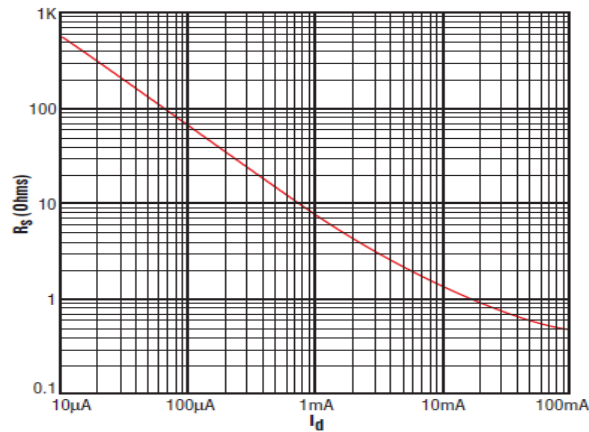

**SMPN7380**

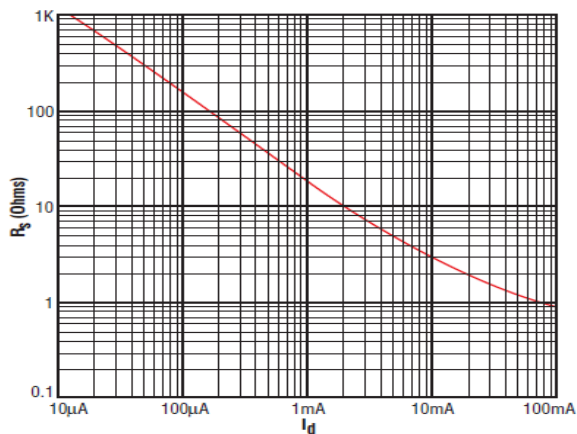

**SMPN7316**

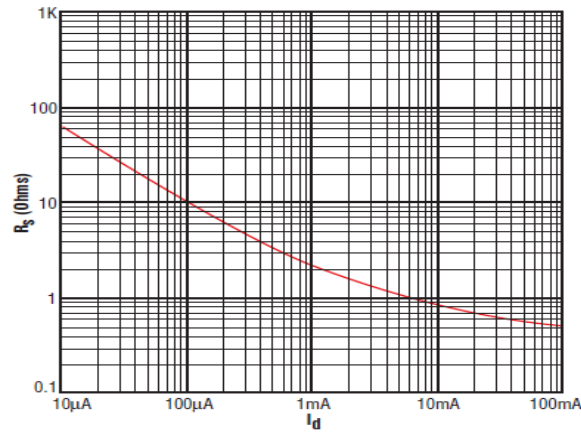

### Typical Resistance Curves

**SMPN7310, @ 1 GHz**

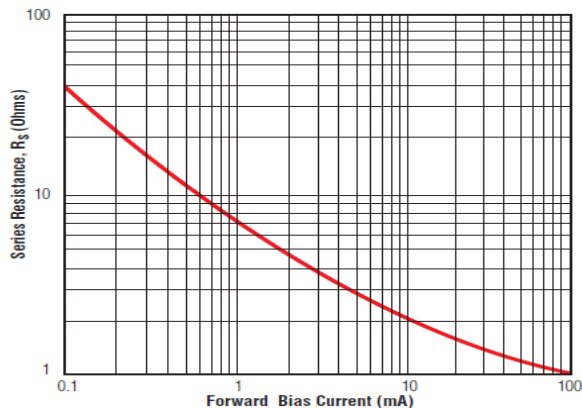

**SMPN7320, @ 1 GHz**

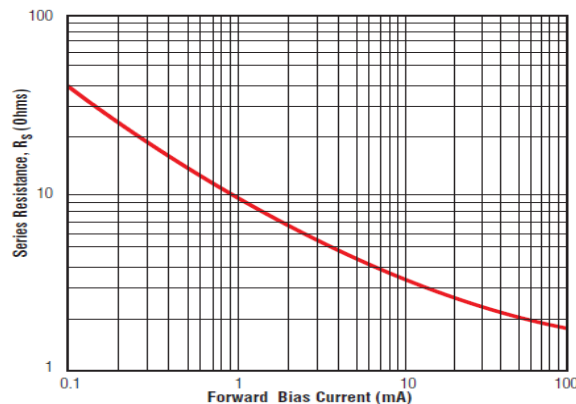

### Typical Resistance Curves @ 100 MHz

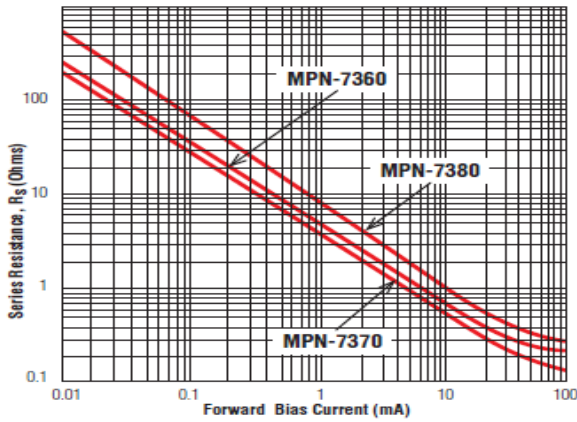
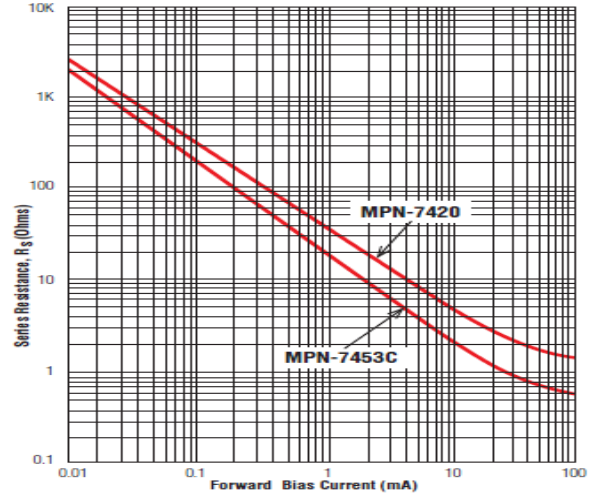
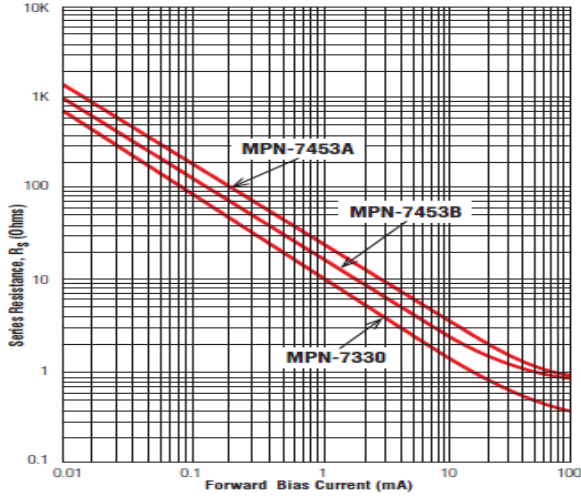

### Outline Drawing - SOT23

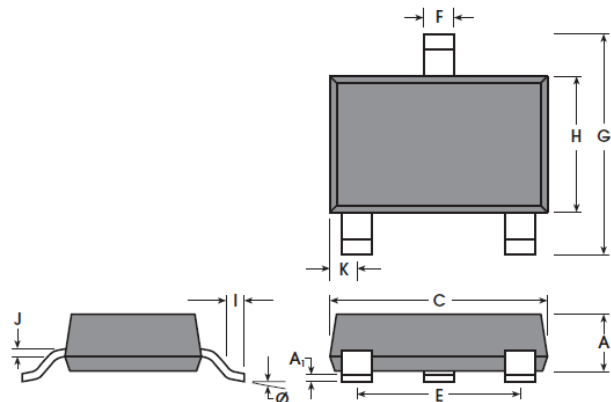

Dim.	Millimeters		Inches	
	Min.	Max.	Min.	Max.
A	0.79	1.02	0.031	0.040
A <sub>1</sub>	0.02	0.10	0.001	0.004
C	2.67	3.05	0.105	0.120
E	1.80	2.00	0.071	0.079
F	0.38	0.54	0.010	0.021
H	2.10	2.50	0.083	0.098
I	0.13	0.25	0.005	0.010
J	0.089	0.15	0.0035	0.059
K	0.44	0.55	0.017	0.022
∅	0.0	8.0	0.0	0.0

Lead Material = Alloy 42  
 Lead Finish = Tin-Lead, 60-40%  
 Maximum Soldering Temperature = 260°C for 5 sec.  
 Minimum Lead Strength = 2 pounds pull  
 Typical Package Inductance = 2 nH  
 Typical Package Capacitance = 0.10 pF (opposite leads)

### Outline Drawing - SOD323

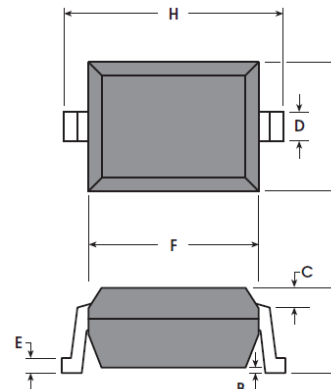

Dim.	Millimeters		Inches	
	Min.	Max.	Min.	Max.
A	—	1.10	0.034	0.043
B	—	0.10	0.003	0.004
C	—	0.20	0.006	0.010
D	0.25	0.40	0.010	0.016
E	0.08	0.15	0.003	0.006
F	1.60	1.90	0.063	0.075
G	1.15	1.45	0.045	0.057
H	2.30	2.70	0.094	0.106

### Ordering Information

Example Part: SMPN7453-SOT23-xx, replace -xx with desired case style suffix	
0S	Single
1S	Single
2ST	Series Tee
3CA	Common Anode
4CC	Common Cathode