

DATA SHEET

SMVA1248-079LF: Hyperabrupt Junction Tuning Varactor

Automotive Applications

- Low tuning voltage VCOs
- Infotainment
- Navigation
- Telematics
- Garage door openers
- Wireless control systems



Features

- AEC-Q101 qualified
- High capacitance ratio: $C_{0.3V}/C_{4.7V} = 12$ typical
- Packages rated MSL1, 260 °C per JEDEC J-STD-020



Skyworks Green™ products are compliant with all applicable legislation and are halogen-free. For additional information, refer to *Skyworks Definition of Green™*, document number SQ04-0074.

Description

The SMVA1248-079LF silicon hyperabrupt junction varactor diode is designed for use in voltage controlled oscillators (VCOs) with a low tuning voltage operation and is ideal for in-vehicle infotainment applications. This varactor is characterized for capacitance and resistance over temperature.

Table 1 describes the SMVA1248-079LF package and marking.

Table 1. Package and Marking

Single
SC-79 Green™
SMVA1248-079LF Marking: Cathode and CH
Ls = 0.7 nH



The Pb-free symbol or "LF" in the part number denotes a lead-free, RoHS-compliant package unless otherwise noted as Green™.

Electrical and Mechanical Specifications

The absolute maximum ratings of the SMVA1248-079LF varactor are provided in Table 2. Electrical specifications are provided in Table 3. Typical capacitance values are listed in Table 4. Typical performance characteristics of the SMVA1248-079LF varactor are illustrated in Figures 1 and 2.

The SPICE model for the SMVA1248-079LF varactor is shown in Figure 3, and the associated model parameters are provided in Table 5.

Table 2. SMVA1248-079LF Absolute Maximum Ratings¹

Parameter	Symbol	Minimum	Maximum	Units
Reverse voltage	V _R		15	V
Forward current	I _F		20	mA
Power dissipation	P _{DIS}		250	mW
Operating temperature	T _{OP}	-55	+125	°C
Storage temperature	T _{STG}	-55	+150	°C
Electrostatic discharge:	ESD			
Charged Device Model (CDM), Class 2			500	V
Human Body Model (HBM), Class 1A			500	V
Machine Model (MM), Class A			<50	V

¹ Exposure to maximum rating conditions for extended periods may reduce device reliability. There is no damage to device with only one parameter set at the limit and all other parameters set at or below their nominal value. Exceeding any of the limits listed here may result in permanent damage to the device.

ESD HANDLING: *Although this device is designed to be as robust as possible, electrostatic discharge (ESD) can damage this device. This device must be protected at all times from ESD when handling or transporting. Static charges may easily produce potentials of several kilovolts on the human body or equipment, which can discharge without detection. Industry-standard ESD handling precautions should be used at all times.*

Table 3. SMVA1248-079LF Electrical Specifications¹
(T_{OP} = 25 °C, Unless Otherwise Noted)

C _T @ 0.3 V (pF)		C _T @ 4.7 V (pF)		C _T @ 1 V (pF)	C _T @ 3 V (pF)	C _T @ 0.3 V C _T @ 4.7 V (Ratio)		C _T @ 1 V C _T @ 3 V (Ratio)	R _s @ 3 V, 500 MHz (Ω)	Q @ 3 V, 50 MHz
Min.	Typical	Typical	Max.	Typical	Typical	Min.	Typical	Typical	Max.	Typical
15.0	17	1.5	1.70	12.3	2.60	10.8	12.0	4.7	3.3	700

¹ Performance is guaranteed only under the conditions listed in this table.
Reverse voltage V_R (I_R = 10 μA) = 15 V minimum
Reverse current I_R (V_R = 12 V) = 20 nA maximum

Table 4. Capacitance vs Reverse Voltage

V_R (V)	C_T (pF)
0	22.62
0.5	16.32
1.0	12.33
1.5	9.12
2.0	6.27
2.5	3.93
3.0	2.57
3.5	1.95
4.0	1.71
4.5	1.59
5.0	1.49
5.5	1.44
6.0	1.40
6.5	1.36
7.0	1.33
7.5	1.31
8.0	1.30

Typical Performance Characteristics

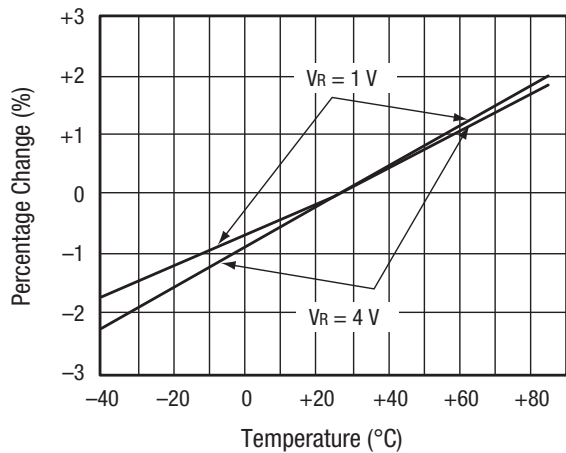

Figure 1. Relative Capacitance Change vs Temperature

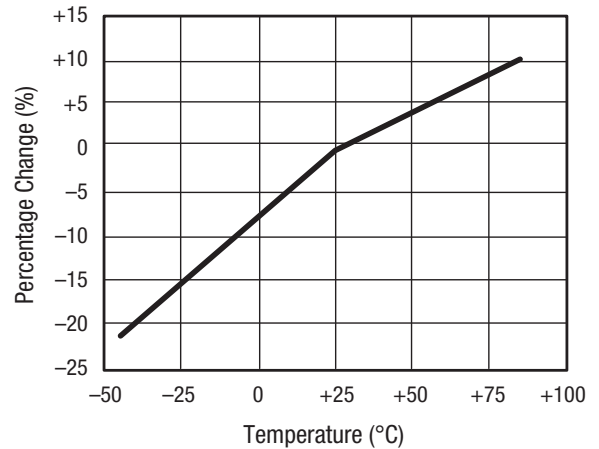

Figure 2. Relative Series Resistance Change vs Temperature @ 500 MHz

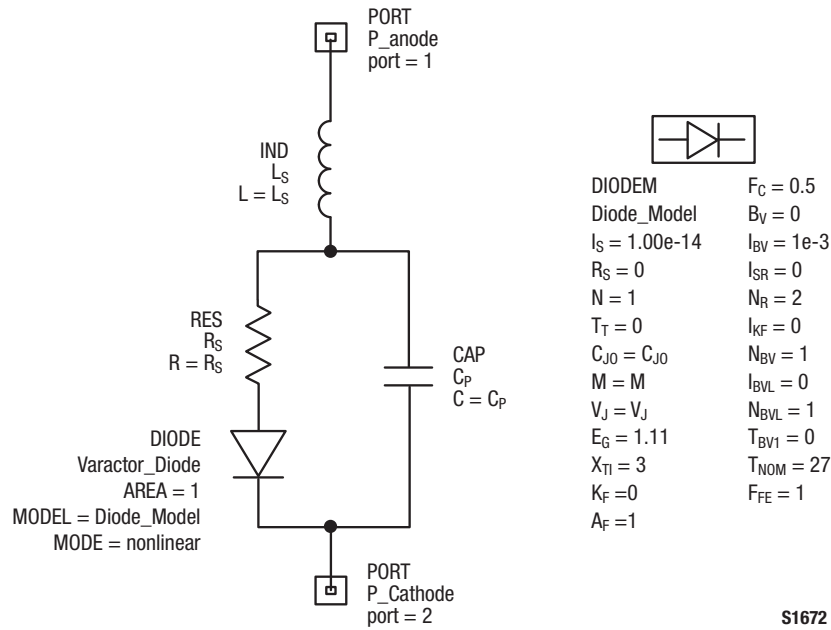

Figure 3. SPICE Model

Table 5. SPICE Model Parameters¹

C _{J0} (pF)	V _J (V)	M	C _P (pF)	R _S (Ω)
22.12	138	100	0.87	2.4

¹ Values extracted from measured performance.
 For package inductance (L_s), refer to Table 1.
 For more details, refer to the Skyworks Application Note, *Varactor SPICE Model for Approved RF VCO Applications*, document number 200315.

Package and Handling Information

Instructions on the shipping container label regarding exposure to moisture after the container seal is broken must be followed. Otherwise, problems related to moisture absorption may occur when the part is subjected to high temperature during solder assembly.

The SMVA1248-079LF varactor is rated to Moisture Sensitivity Level 1 (MSL1) at 260 °C. The device can be used for lead or lead-free soldering.

For additional information, refer to the Skyworks Application Note, *Solder Reflow Information*, document number 200164.

Care must be taken when attaching this product, whether it is done manually or in a production solder reflow environment. Production quantities of this product are shipped in a standard tape and reel format.

Package dimensions are shown in Figure 4, and tape and reel dimensions are provided in Figure 5.

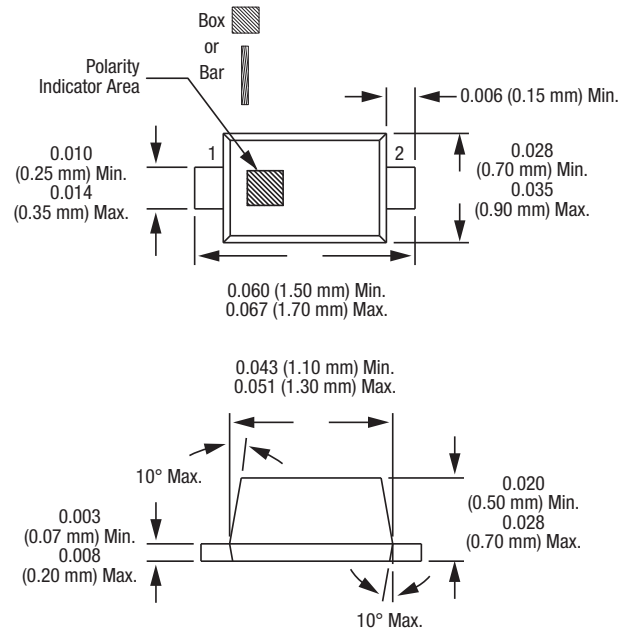

Dimensions are in inches (millimeters shown in parentheses)

S1652

Figure 4. SC-79 Package Dimensions

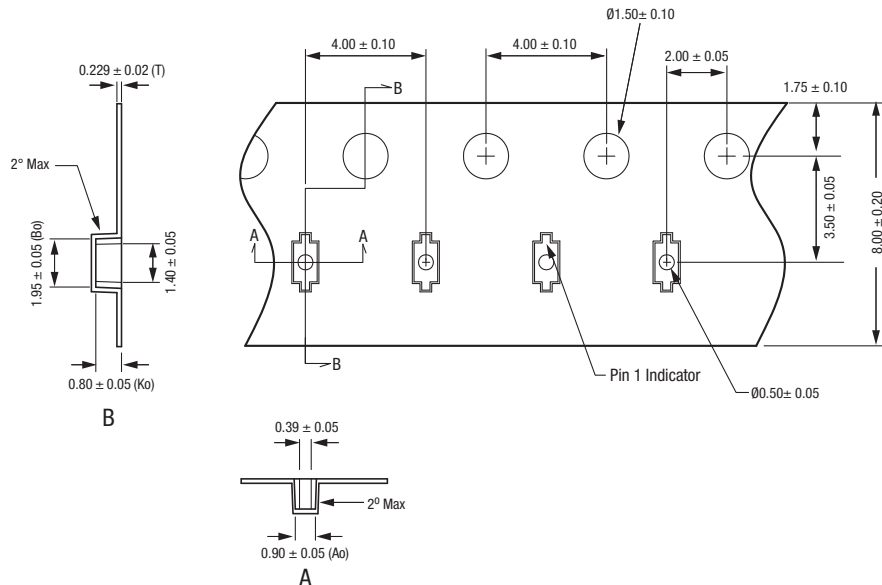

Notes:

1. Carrier tape: black conductive polycarbonate or polystyrene.
2. Cover tape material: transparent conductive PSA.
3. Cover tape size: 5.4 mm width.
4. ESD-surface resistivity is $\leq 1 \times 10^8$ Ohms/square per EIA, JEDEC TNR Specification.
4. All measurements are in millimeters.

S2929

Figure 5. SC-79 Tape and Reel Dimensions