

SNDH-H SERIES

005933
Issue 5

Speed Sensors

DESCRIPTION

The SNDH-H Series Hall-Effect Speed Sensors uses a magnetically biased Hall-effect integrated circuit to accurately sense movement of ferrous metal targets. The specially designed IC (integrated circuit) and a permanent magnet are sealed in rugged, probe-type packages. The flux density of the permanent magnet alters when approached by ferrous metal. This is detected by the Hall ICs. If the sensor is positioned at the circumference of a revolving gear wheel, for example, it detects the teeth and tooth spaces, supplying a digital pulse output with frequency proportional to gear wheel speed. Optimum performance is dependent upon variables which must be considered in combination: target material, geometry and speed, sensor/target gap, and environmental temperature.

POTENTIAL TRANSPORTATION APPLICATIONS

- Transmission speed sensing in heavy duty trucks, buses, agriculture and construction machines
- Wheel speed detection in material handling, agriculture, and construction machines
- Motor speed sensing in vehicle powertrain and hybrid engines in heavy duty trucks, buses, agriculture and construction machines

Not recommended for Aerospace or Defense applications.

FEATURES

- Solid state, non-contacting Hall-effect magnetic sensing allows the device the ability to sense through dust, dirt and debris, enhancing reliability and product life
- Air gap up to 2,5 mm allows the sensor to be located up to 2,5 mm away from the target
- High frequency switching capability (to 15 kHz) allows the device to handle high RPMs (SNDH-H3L-G01)
- O-ring seal allows device to be sealed into housings
- Two housing materials allow flexibility within the application: stainless steel (corrosion and rust resistant): SNDH-H3L-G01; plastic: SNDH-H3C-G04, SNDH-H3P-G01
- Various probe lengths (20,3 mm, 27,5 mm, and 40 mm) simplify use within the application
- High operating temperature of -40°C to 125°C (SNDH-H3P-G01 and SNDH-H3C-G04) allows the device to be used in high temperature applications (e.g., engines)
- Digital current sinking output (open collector) simplifies electrical interfacing to control systems.
- Multiple connector options (Bosch 928000453, Delphi-Packard Metripak 150.2 Type 101, Deutsch DT06-3S) simplify installation
- Omnidirectional capability eliminates the need to align the sensor to the target, allowing the user to simply bolt the device (SNDH-H3C-G0, SNDH-H3L-G01)



- Zero speed versions indicate that the rotation has stopped, allowing the device to work at extremely low RPMs (SNDH-H3L-G01, SNDH-H3C-G04, SNDH-H3P-G01)
- Stable performance over temperature range and air gap range



PORTFOLIO

The SNDH-H Series joins the SNG-S Series, the LCZ Series, and the ZH10 Series Hall-Effect Speed Sensors. For speed and direction sensors, see the SNG-Q Series and the SNDH-T Series To view the entire product portfolio, [click here](#).

Honeywell

SPEED SENSORS, SNDH-H SERIES

TABLE 1. SPECIFICATIONS

CHARACTERISTIC	SNDH-H3L-G01	SNDH-H3C-G04	SNDH-H3P-G01
Supply voltage range	4 Vdc to 24 Vdc	6.5 Vdc to 24 Vdc	
Output	digital current sinking (open collector)		
Supply current	6 mA max.	14 mA max.	
Output current	30 mA ¹	20 mA sinking	
Output leakage current		10 µA	
Reverse output voltage	-	-0.5 V	
Rise time (10% to 90%)	400 ns	1 µs	1 µs
Fall time (90% to 10%)	400 ns	0.6 µs	0.6 µs
Target orientation	omnidirectional	alignment required	
Zero speed		yes	
Operating frequency range	0 kHz to 15 kHz	0 kHz to 12 kHz	
Operating temp. range	-40°C to 100°C	-40°C to 125°C	
Dielectric	200 Vdc	-	
Housing material	stainless steel	plastic	
Sensing air gap		up to 2,5 mm [0.098 in]	
Target tooth width	2 mm	3 mm	
Target slot width	2 mm	>2 mm	
Tooth height	5 mm	>2 mm	
Target width	≥3 mm	>2 mm	
Sensor misposition to target		dependent on target geometry	
Probe length	40 mm	27,5 mm	20,3 mm
Probe diameter	9,53 mm	18,6 mm	15,37 mm
Connector	leaded ³	Delphi-Packard Metripak 150.2 Type 101	Deutsch DT06-3S

¹ Short circuit protected.

TABLE 2. ORDER GUIDE

CATALOG LISTING	DESCRIPTION
SNDH-H3L-G01	SNDH-H Series, Hall-effect speed sensor, zero speed, omnidirectional, stainless steel, 40 mm probe length, leaded connector
SNDH-H3C-G04	SNDH-H Series, Hall-effect speed sensor, zero speed, plastic, 27,5 mm probe length, Delphi-Packard Metripak 150.2 Type 101 connector
SNDH-H3P-G01	SNDH-H Series, Hall-effect speed sensor, zero speed, plastic, 20,3 mm probe length, Deutsch DT06-3S connector

SPEED SENSORS, SNDH-H SERIES

FIGURE 1. MOUNTING DIMENSIONS (FOR REFERENCE ONLY: MM.)

SNDH-H3L-G01

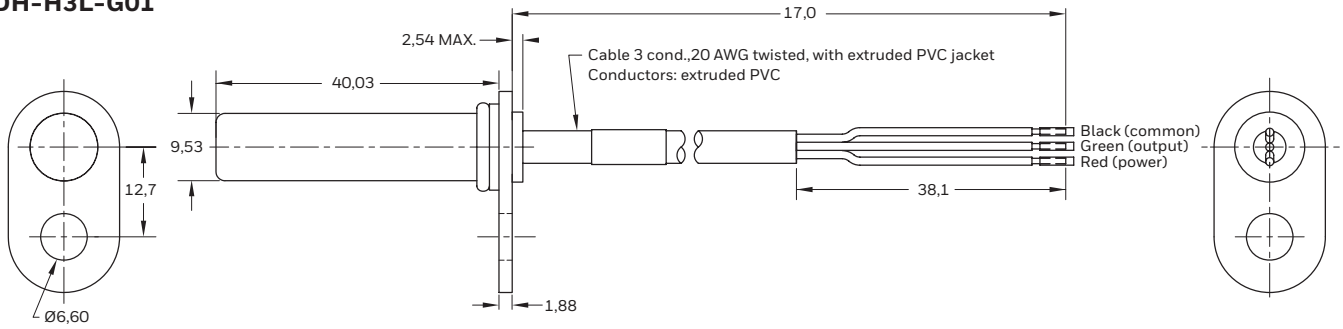

SNDH-H3C-G04

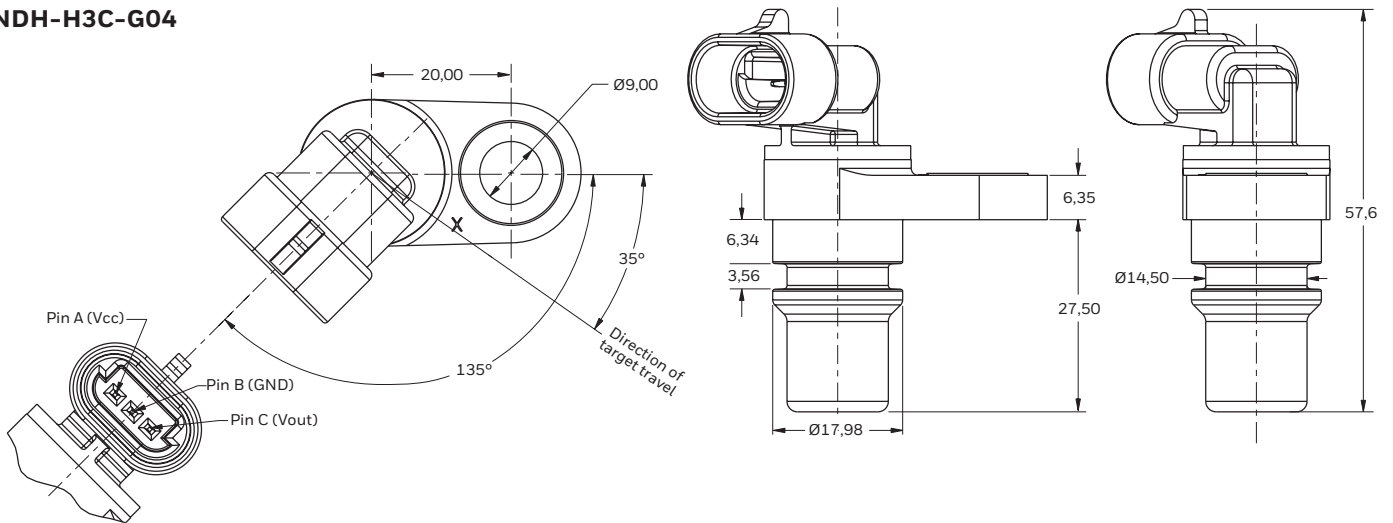

SNDH-H3P-G01

