

SNDH-T Series

Quadrature General Industrial Speed and Direction Sensors



DESCRIPTION

The SNDH-T Series is a dual differential hall sensor that provides speed and direction information using a quadrature output with signals 90° phase shifted from each other. Target direction is determined by output lead/lag phase shifting.

This product is designed for applications where extremely high resolution is required at wide frequency ranges, 1 kHz to 15 kHz, and large air gaps. BiCMOS (bipolar complementary metal-oxide-semiconductor) Hall-effect technology, using advanced digital signal processing for dynamic off-set cancellation, provides enhanced air gap performance and phase shift accuracy over most conditions.

FEATURES

- Hall-effect magnetic sensing technology
- Dual differential Hall provides enhanced target resolution
- Advanced performance dynamic offset self calibration
- Air gap up to 2 mm [0.08 in]
- Near zero speed
- Automotive under-the-hood packaging integrity
- EMI hardened
- High frequency switching capability (1 Hz to 15 kHz)
- -40 °C to 150 °C [-40 °F to 302 °F] continuous operating temperature
- Multiple connector options
- Short circuit protection
- Reverse voltage protection
- Open collector output
- Low jitter output
- O-ring seal

Unique patented (pending) IC (integrated circuit) packaging provides output phase shift tolerancing with enhanced accuracy.

The robust package is automotive under-the-hood grade for most environmental conditions as well as EMI (electromagnetic interference) hardened. Multiple connection options, including wire harness and integral connector versions using AMP super seal or AMP Jr. Timer connectors, are available. Package design includes an o-ring seal for pressure applications and a fixed mounting flange.

POTENTIAL APPLICATIONS

- Steering position
- Tachometers/counters
- Encoders
- Speed and direction of gears and shafts in transmissions, hydraulic motors, pumps, and gear boxes

SNDH-T Series

Table 1. Specifications

Characteristic	Parameter	Note
Sensing air gap	0 mm to 2,0 mm [0 in to 0.08 in]	may achieve larger gaps with testing of actual target
Target tooth width	2,0 mm [0.08 in] (recommended)	other geometry may be suitable
Target slot width	2,0 mm [0.08 in] (recommended)	other geometry may be suitable
Tooth height	>3,0 mm [0.12] (recommended)	shorter tooth heights may limit max. air gap performance
Target width	>5,0 mm [0.20] (recommended)	narrow targets may limit axial offsets
Sensor misposition to target	±1,5 mm [0.06]	dependent on target geometry
EMI radiated immunity	100 V/m peak	400 Hz to 2 GHz
EMI bulk current injection	60 mA	20 MHz to 400 MHz
EMI ESD	16/8 KV air/contact	against the connector (150 pF, 330 Ohm)
EMI fast transient burst	EN61000-4-4 Level 4	—
Operating temperature	-40 °C to 150 °C [-40 °F to 302 °F]	continuous
Thermoshock	-40 °C to 150 °C [-40 °F to 302 °F]	—
Humidity	168 hr	95% humidity at 90 °C [194 °F]
Salt fog	96 hr	DIN IEC 6872-11
Thermosaline dunk	5 dunks	105 °C to 0 °C [221 °F to 32 °F] air to liquid, 5% saline
High temp exposure with power	1000 hr at 150 °C [302 °F]	—
Mechanical shock	50 g	—
Vibration	30 g, 10 Hz to 2 kHz	—
Resistance to fluids	general automotive under the hood fluids	—
Supply voltage	4.5 V to 18 V	—
Max. continuous supply voltage	18 V	—
Reverse voltage	-18 V max.	continuous
Current (normal)	13.6 mA	all conditions
Current (max.)	18 mA	all conditions
Short circuit protection	80 mA	—
Output signal type	square wave	two channel, phase shifted by 90°, either channel can lead or lag, push/pull
Duty cycle	50% ±10%	—
Phase shift	90° ±20°	using recommended target tooth/slot
Output high	≥Vs -0.5 V	—
Output low	≤0.5 V	—
Load current	20 mA max.	each output at all conditions
Output low	≤0.5 V	—
Rise time	10 μs typ.	dependent on load resistor
Fall time	1 μs typ.	—
Frequency	1 Hz to 15 kHz	higher frequencies about 10 kHz may be dependent on target geometry and air gap

Figure 1. Wiring Diagram

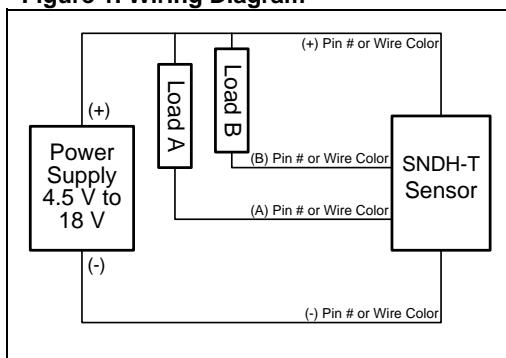

Figure 2. Sensor Output

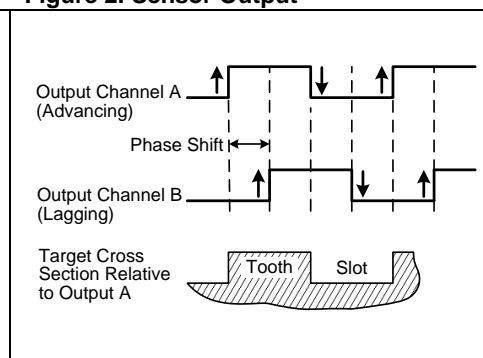
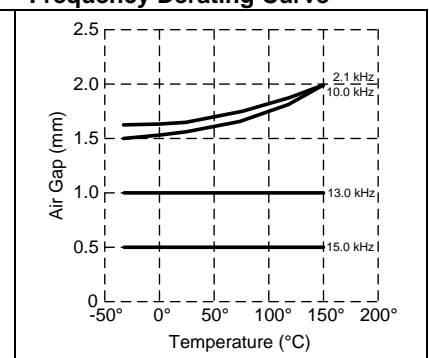

Figure 3. Temperature Air Gap Frequency Derating Curve



Quadrature Speed and Direction Sensors

Figure 4. Mounting Dimensions and General Mounting Geometry (For reference only: mm [in.])

