

# INSTALLATION INSTRUCTIONS FOR THE SPEED SENSORS, SNG-S SERIES

**32347440**

Issue A

## GENERAL SPECIFICATIONS

Honeywell's SNG-S Series Speed Sensors use a magnetically biased Hall-effect integrated circuit (IC) to accurately sense movement of ferrous metal targets. The specially designed IC and a permanent magnet are sealed in rugged, probe-type packages. The IC detects the alteration of the magnet's flux density when it is approached by ferrous metal. A sensor

positioned at the circumference of a revolving gear wheel detects the teeth and spaces, and supplies a digital pulse output with frequency proportional to gear wheel speed. Optimum performance is dependent upon a combination of variables such as target material, geometry and speed, sensor/target gap, and environmental temperature.

**TABLE 1. ELECTRICAL SPECIFICATIONS**

CHARACTERISTIC	CONDITION/COMMENT	PARAMETER			
		SNG-SPRF-002	SNG-SPRD-002 SNG-SPSC-001 SNG-SPRC-001	SNG-SPRD-003 SNG-SPRC-002	SNG-SPRD-004 SNG-SPRC-003
Supply voltage	regulated supply and 12 V battery ISO 16750-2	4.5 V to 24 V –	– 8 V to 16 V	– 4.8 V to 16 V	– 4.8 V to 24 V
Supply current	–	20 mA max.		15 mA	
Reverse voltage protection	– ISO 16750-2	-24 V –		– -14 Vdc	
Over voltage protection	– ISO 16750-2	26.5 V –		– 26 V	
Short circuit protection	– ISO 16750-2	16 V –		– 16 V	
Load dump	ISO 16750-2:2012 11 01 (US* = 40 V, UA 13.5 ±0.5 V)	5b –		– –	
Insulation resistance	ISO 16750-2:2012	>10 MOhm at 500 Vdc –		– –	

**TABLE 2. MECHANICAL SPECIFICATIONS**

CHARACTERISTIC	PARAMETER			
	SNG-SPRF-002	SNG-SPRD-002 SNG-SPSC-001 SNG-SPRC-001	SNG-SPRD-003 SNG-SPRC-002	SNG-SPRD-004 SNG-SPRC-003
Carrier material	PBT thermoplastic		PBT	
Bushing material	SS304		SSTL	
O-ring material	70 durometer fluorocarbon, PTFE coating, 17,17 mm ID x 1,78 CS		fluorocarbon, brown, 17,17 mm ID x 1,78 CS	
Housing material	PBT		PBT	
Connector: integral mating	Bosch 928000453 Bosch 1928403966		Amp Superseal 1.5 282087	
Mounting torque	8 ±0,5 N m with M6 screw		20 ±3 N m with M8 screw	
O-ring lubrication		mineral oil-based grease		

**TABLE 3. ENVIRONMENTAL SPECIFICATIONS**

CHARACTERISTIC	CONDITION/COMMENT	PARAMETER	
		SNG-SPRF-002	ALL OTHER CATALOG LISTINGS
Radiated immunity	ISO 11452-2: 2004 ISO 11452-2: 2004 IEC 61000-4-3: 2008 ISO 11452-2, 400 MHz to 2.5 GHz	10 kHz to MHz, 60 m/V 200 MHz to 2.7 GHz, 100 V/m 800 kHz MHz to 1000 MHz, 3 m/V –	– – – 100 V/m
Bulk current injection	ISO 11452-4, 1 MHz to 400 MHz	100 mA	
ESD	SAE J1113/13 ISO 10605	±4 kV contact, ±8 kV air –	– ±8 kV contact, ±15 kV air
Conductive transients	ISO 7637-2, for 12 V system ISO 7637-2, for 12 V system	TEST PULSE 1, 2a, 2b, 3a, 3b –	– PULSE 1, 2a, 3a, 3b, 5a
Conducted emissions	CISPR 25. 150 kHz to 108 MHz	–	Class 3
Radiated emissions	CISPR 25. 150 kHz to 12.5 GHz	–	Class 3
Thermal cycle	-40°C to 140°C	–	100 cycles
Humidity	–	10 %RH to 90 %RH at -40°C to 85°C, 150 cycles, 600 hr total	–
	95 %RH at 55°C	–	144 hr, EN/IEC 60068-2-30
Saline dunk	0°C to 110°C	–	10 cycles, ISO 16750-4
Salt fog	5% salt solution by mass at 35°C and 93% RH for 400 hr, tested to 2000 hr with no ingress in the sensor packaging area	5% salt solution by mass at 35°C and 93% RH for 2000 hr	–
	5% salt solution by mass at 35°C	–	96 hours
Combined temperature and vibration test	sinusoidal: 25 hr/axis, 3 perpendicular axes 30 g at 60 Hz to 1000 Hz and 15 g at 1000 Hz to 2000 Hz	sinusoidal: 25 hr/axis, 3 perpendicular axes 15 g at 5 Hz to 2000 Hz	–
	random: 25 hr/axis, 3 perpendicular axes 30 g at 25 rms Hz to 2000 Hz, -40°C to 125°C	random: 25 hr/axis, 3 perpendicular axes at 25 grms at 10 Hz to 2000 Hz	–
Vibration	3 perpendicular axes, 48 hr per axis	–	29.8 GRMS, 24 Hz to 2000 Hz, MIL-STD-202-214
Degree of protection	IEC 50629 IEC 60529	IPX6, IPX9K, IPX7 –	– IP69K, IP67
Resistance to fluids	–	–	general under-the-hood automotive fluids
Operating temperature	–	-40°C to 150°C	-40°C to 140°C
Storage temperature	–	-55°C to 70°C	-40°C to 140°C

**FIGURE 2. SCHEMATIC DIAGRAMS AND OUTPUT SPECIFICATIONS**

**SNG-SPRF-002**

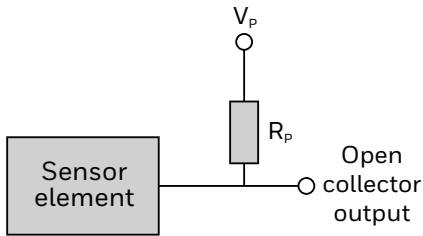

CHARACTERISTIC	CONDITION/COMMENT	PARAMETER
Signal type	open collector	square wave
Power on	–	default high and start from initial edge
Signal polarity	not dependent on target rotation	output low on teeth
Output signal: high low	– –	$\geq V_p - 0.5 V$ $\leq 0.6 V$
Load current	output leakage current -10 $\mu A$	10 mA max.
Frequency	–	0 kHz to 10 kHz

**SNG-SPRD-002**  
**SNG-SPSC-001**  
**SNG-SPRC-001**

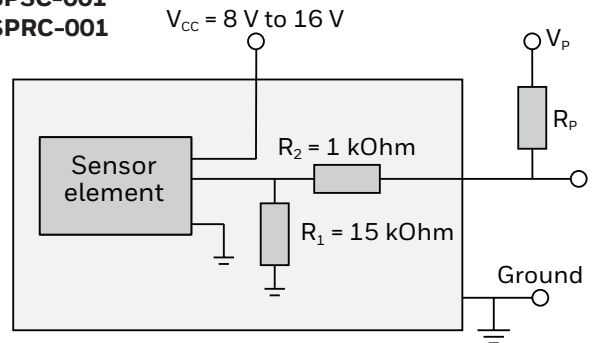

CHARACTERISTIC	CONDITION/COMMENT	PARAMETER
Signal type	open collector	square wave
Output signal: high low	dependent on target geometry and sensor-to-target orientation	$(V_p \times (16.5)) / (16.5 + R_p \text{ in kOhm})$ 0.3 V to 2.2 V $\leq ((V_p - 0.4) \times 1 k) / (1 k + R_p \text{ in kOhm}) + 0.4$
Load current	–	15 mA
Frequency	–	0 kHz to 10 kHz

**SNG-SPRD-003**  
**SNG-SPRC-002**

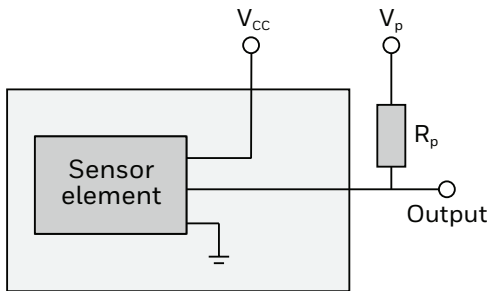

CHARACTERISTIC	CONDITION/COMMENT	PARAMETER
Signal type	open collector	square wave
Output signal: high low	dependent on the controller interface	$\geq V_{cc} - 0.5 V$ $\leq 0.5 V$
Load current	–	20 mA
Frequency	–	0 kHz to 10 kHz

**SNG-SPRD-004**  
**SNG-SPRC-003**

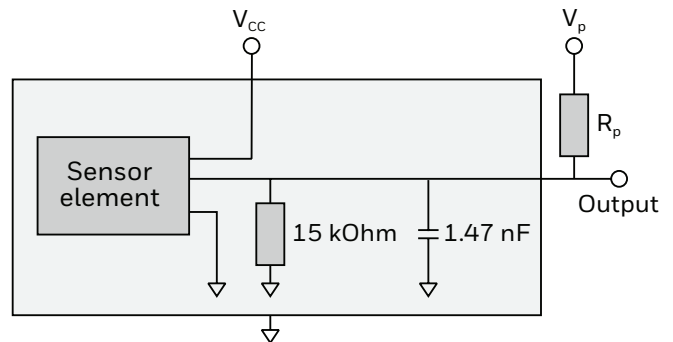

CHARACTERISTIC	CONDITION/COMMENT	PARAMETER
Signal type	open collector	square wave
Output signal: high low	dependent on the controller interface	$(V_p \times (16.5)) / (16.5 + R_p \text{ in kOhm})$ 0.5 V $< 0.5 V$
Load current	–	20 mA
Frequency	–	0 kHz to 10 kHz

**FIGURE 3. MOUNTING DIMENSIONS (FOR REFERENCE ONLY: MM/[IN.] )**

**24 mm, right angle:  
SNG-SPRF-002**

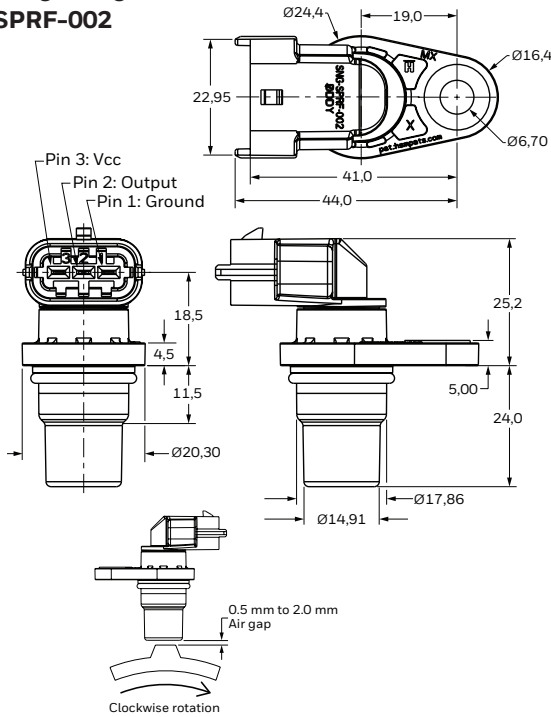

**46 mm, straight:  
SNG-SPSC-001**

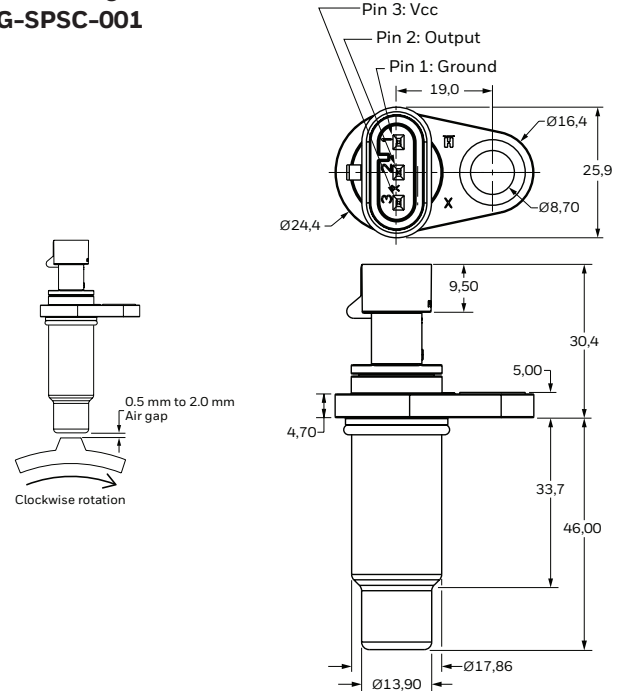

**46 mm, right angle:  
SNG-SPRC-001  
SNG-SPRC-002  
SNG-SPRC-003**

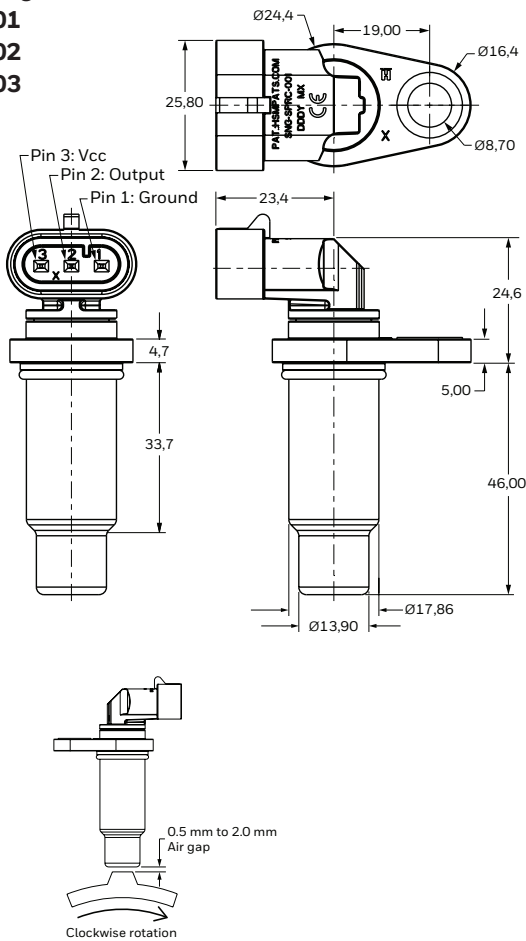

**67 mm, right angle:  
SNG-SPRD-002  
SNG-SPRD-003  
SNG-SPRD-004**

