



# TAOGLAS®



# Datasheet

**Globalstar 25mm 1615Mhz**

**Part No:**  
SP.1615.25.4.A.02

**Description:**  
25\*25\*4mm Globalstar 25mm 1615Mhz

**Features:**  
Embedded Ceramic Patch Antenna  
Globalstar 1615Mhz  
Dimensions: 25\*25\*4mm  
RoHS & Reach Compliant

1.	Introduction	3
2.	Specifications	4
3.	Antenna Characteristics	5
4.	Radiation Patterns	7
5.	Mechanical Drawing	10
6.	PCB Footprint Recommendation	11
7.	Antenna Integration Guide	13
8.	Mechanical Drawing - Evaluation Board	18
9.	Recommended Reflow Soldering Profile	19
10.	Packaging	20
	Changelog	22

Taoglas makes no warranties based on the accuracy or completeness of the contents of this document and reserves the right to make changes to specifications and product descriptions at any time without notice. Taoglas reserves all rights to this document and the information contained herein. Reproduction, use or disclosure to third parties without express permission is strictly prohibited. Copyright © Taoglas Ltd.



## 1. Introduction



This miniaturized 25mm square ceramic patch antenna is mounted via pin and double-sided adhesive and is the optimal embedded antenna solution for mobile Globalstar applications.

The antenna is tuned to a reference 60mm square ground-plane. With an efficiency of nearly 80% at 1615 MHz, the antenna exhibits excellent upper hemisphere radiation pattern stability. Axial ratio is less than 3 on antenna operational angles, with a minimum axial ratio of 0.54 at zenith. The SP.1615.25.4.A.02 gain and directivity characteristics have been analyzed and approved by Globalstar.

Different device ground-planes and housing environments may require a custom tuned antenna. Taoglas provides testing and support services to characterize this antenna in your device and determine whether a custom tuned solution is necessary. There is a minimum order quantity and possible NRE for a custom solution.

For further information or support with integrating this antenna into your device, please contact your regional Taoglas customer support team.

## 2. Specifications

Electrical		
Parameter	Specification	Notes
Range Of Receiving Frequency	1615.68 ± 4.1 MHz	
Center Frequency	1615 MHz ± 3 MHz	With 60×60mm GND Plane
Bandwidth	26 MHz min	Return Loss@-10 dB
VSWR	1.5 max	Center Frequency
Peak Gain	5 dBi	
Polarization	LHCP	Left Hand Circular Polarization
Axial Ratio	3 Max. @ Zenith	
Impedance	50 Ohm	

Mechanical	
Ceramic Dimension	25*25*5mm
Weight	5.8g

Enviorinmental	
Frequency Temperature Coefficient	-40°C to +105°C
Operating Temperature	-40°C to +105°C

### 3. Antenna Characteristics

#### 3.1 Return Loss

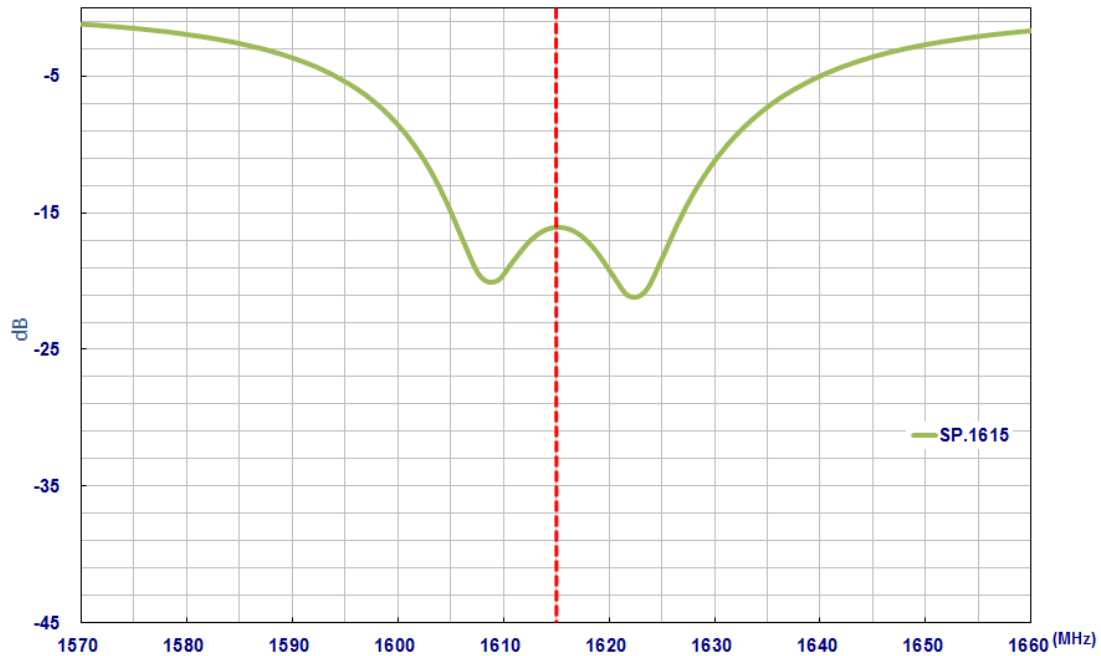

#### 3.2 Efficiency

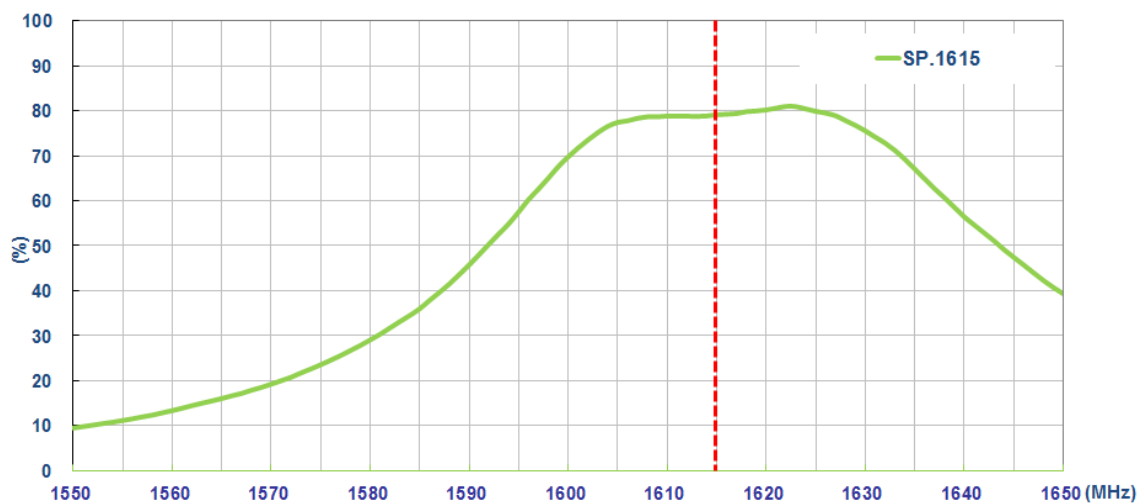

### 3.3 VSWR

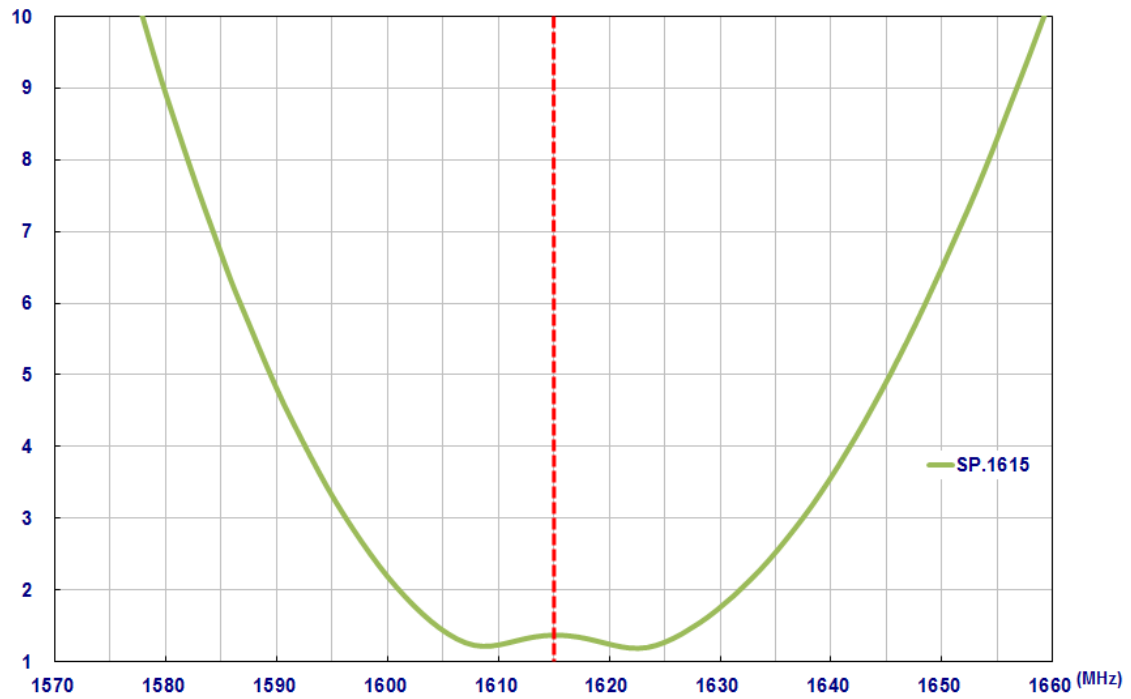

### 3.4 Peak Gain

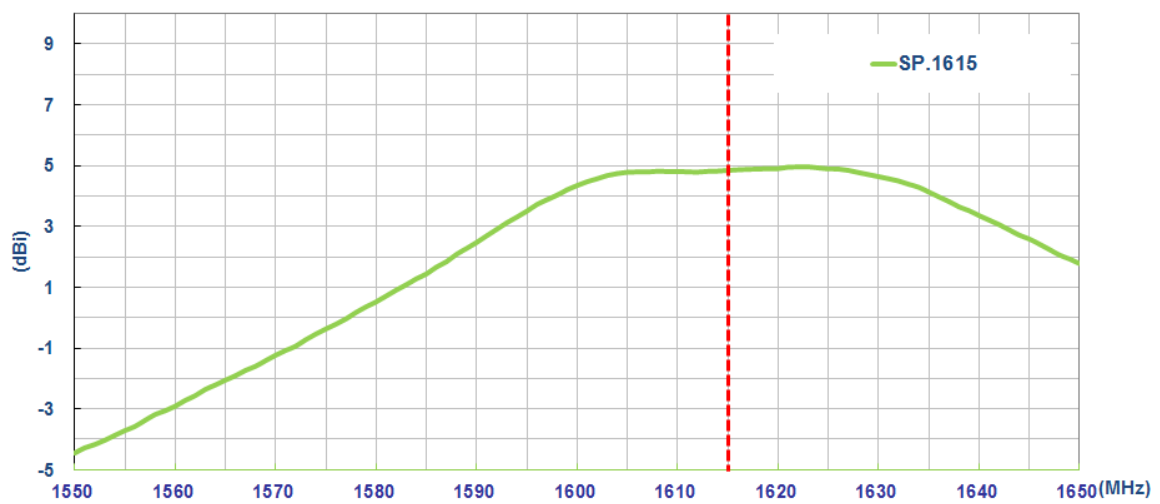

## 4. Radiation Patterns

### 4.1 Test Setup

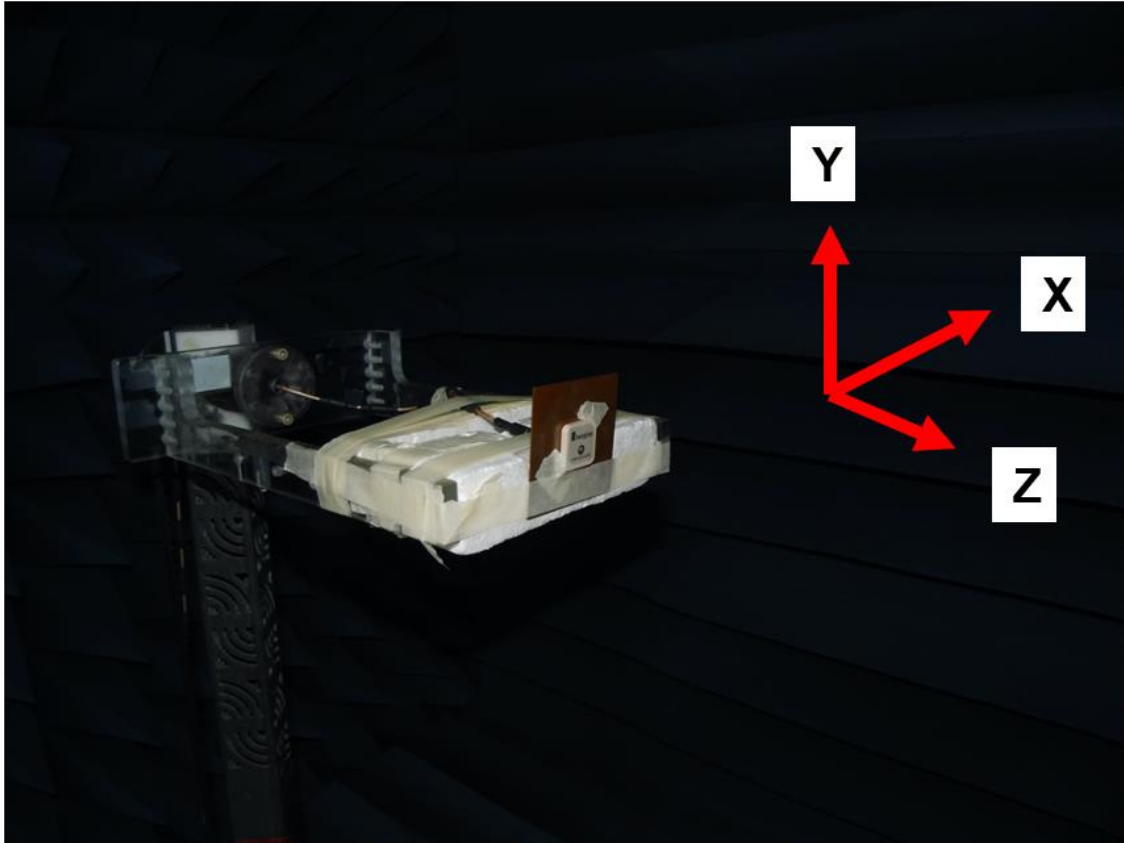

The antenna is tested in a CTIA certified ETS-Lindgren Anechoic Chamber

## 4.2 2D Radiation Patterns

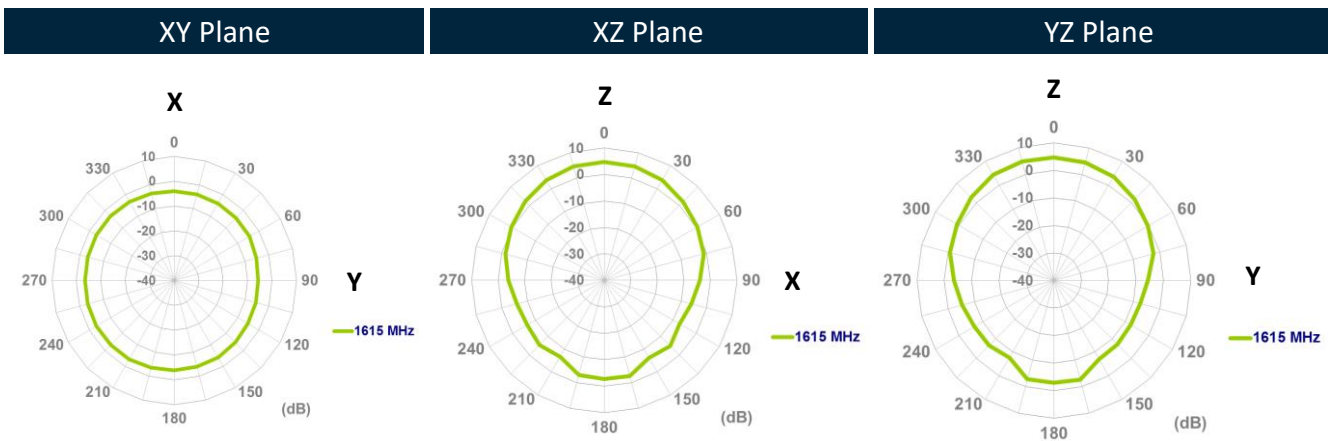



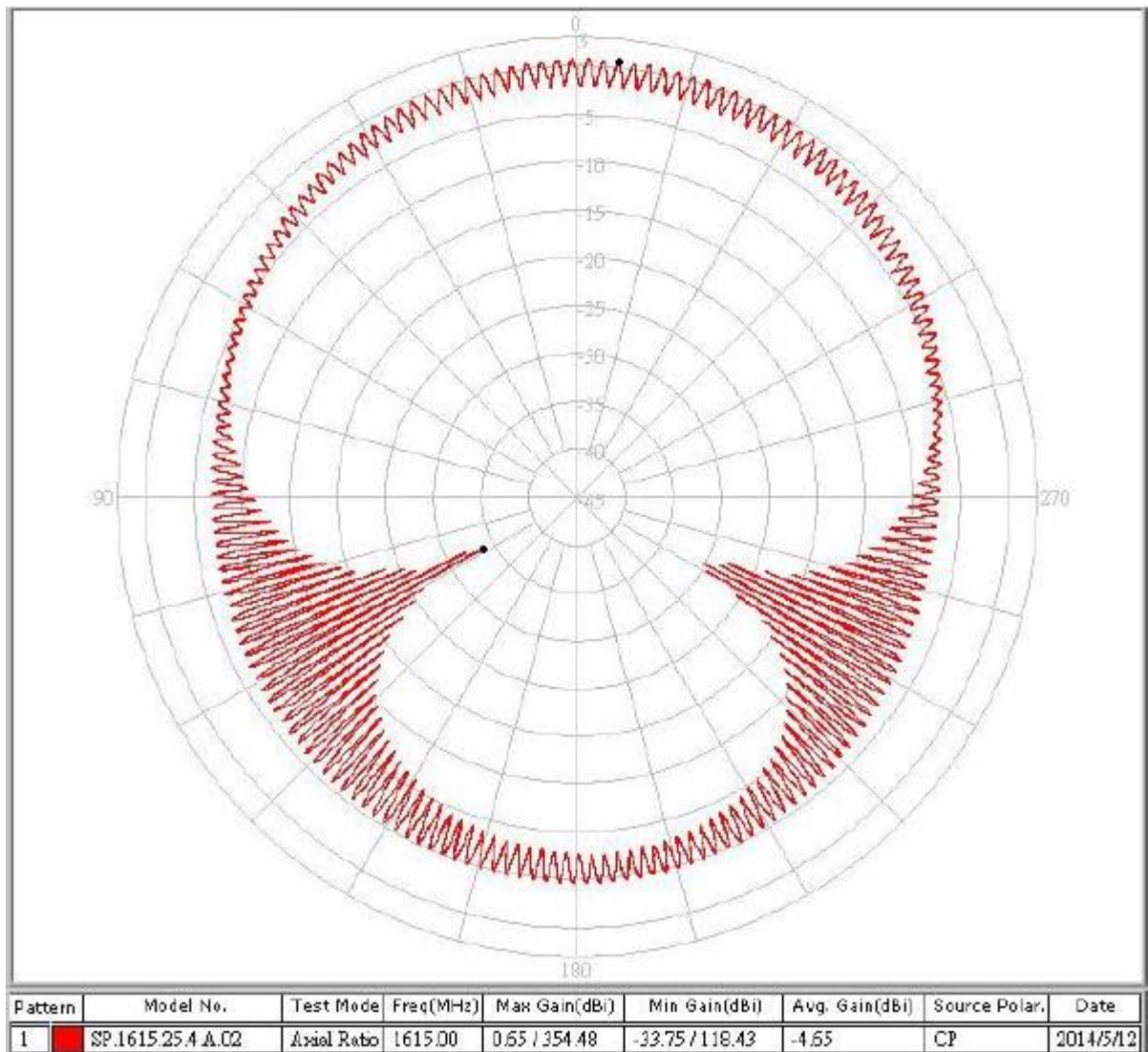

### 4.3 Axial Ration

## 1615MHz

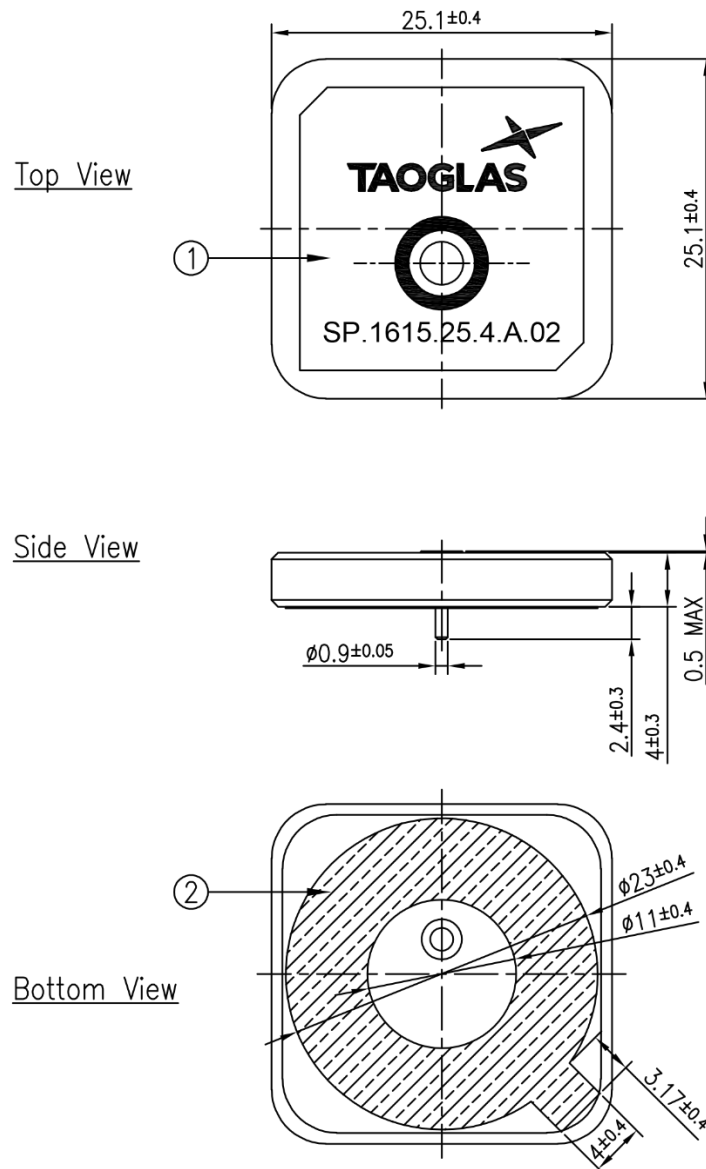

# 5. Mechanical Drawing (Units: mm)



NOTES: 1. Double Sided Adhesive Area.   
 2. Soldermask Area 

	Name	P/N	Material	Finish	QTY
1	Patch	001518A030000A	Ceramic	Clear	1
2	Double sided Adhesive	001518A030000A	NITTO 5015	White Linter	1

## 6. PCB Footprint Recommendation

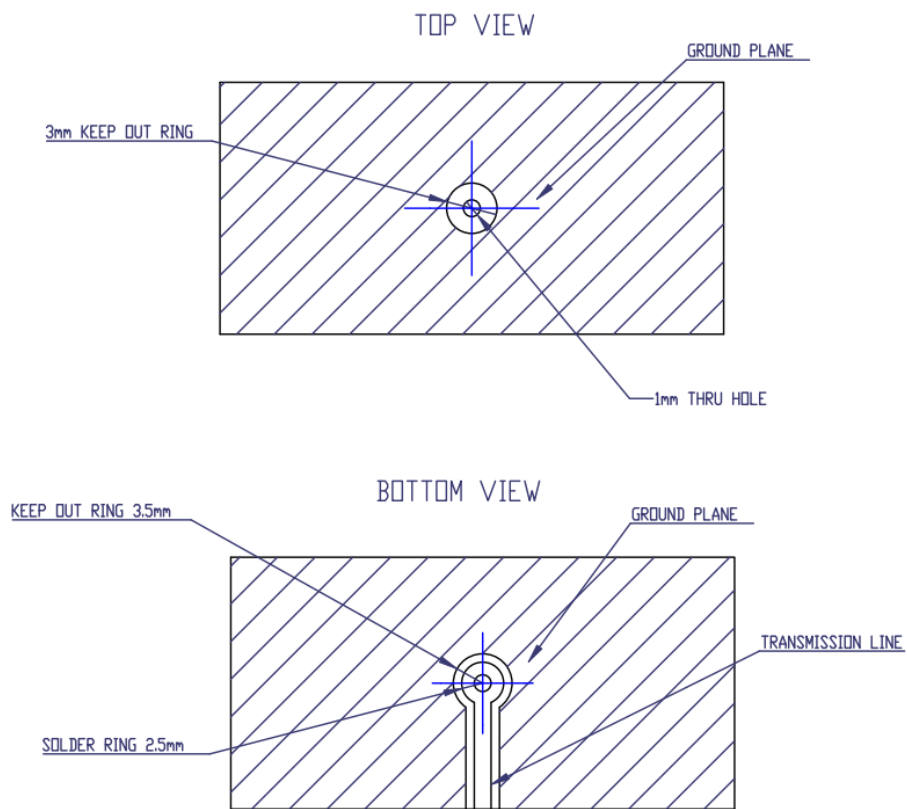

## 7. Antenna Integration Guide



## 7.1 Schematic Symbol and Pin Definition

The circuit symbol for the antenna is shown below. The antenna has 1 pin as indicated below.

Pin	Description
1	RF Feed

TAOGLAS\_SP.161525.4.A.02  
ANTI

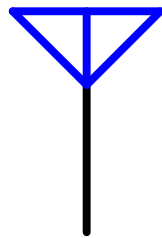

## 7.2 Antenna Integration

The antenna should be placed at the center of the ground plane with a length and width of 60mm. Maintaining a square symmetric ground plane shape and symmetric environment around the antenna is critical to maintaining the excellent axial ratio and phase center performance shown in this datasheet.

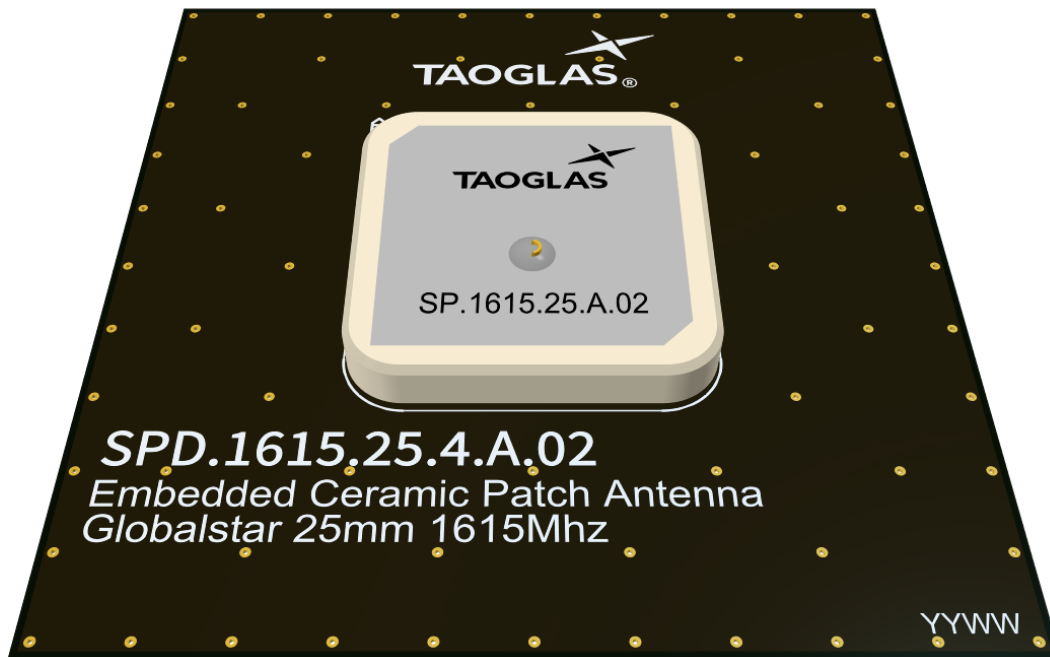

Top Side w/ Solder Mask



Top Side w/o Solder Mask

## 7.3 PCB Layout

The footprint and clearance on the PCB must comply with the antenna specification. The PCB layout shown in the diagram below demonstrates the antenna footprint.

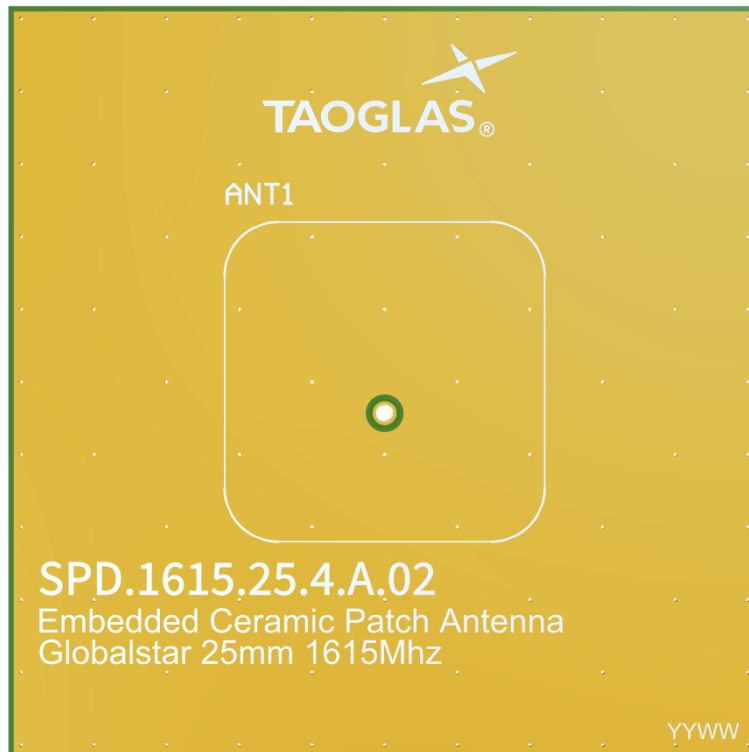

Topside

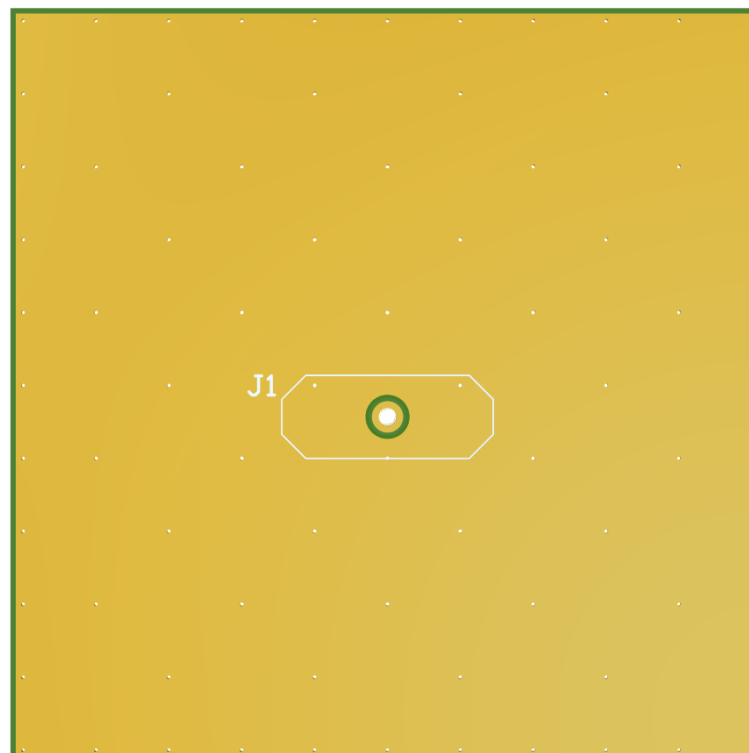

Bottom Side

7.4 Evaluation Board

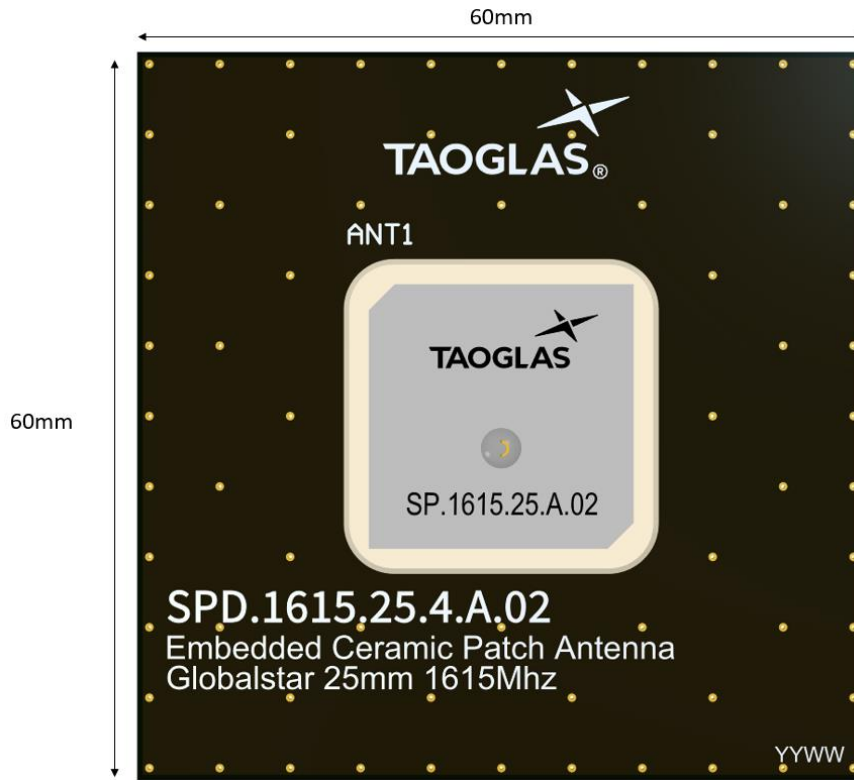

Topside

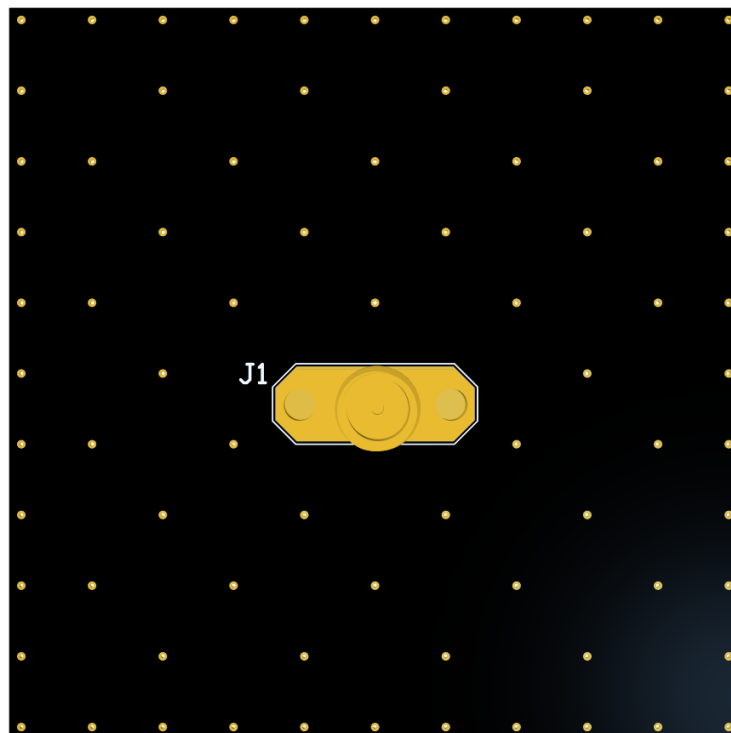

Bottom Side



# 8. Mechanical Drawing – Evaluation Board

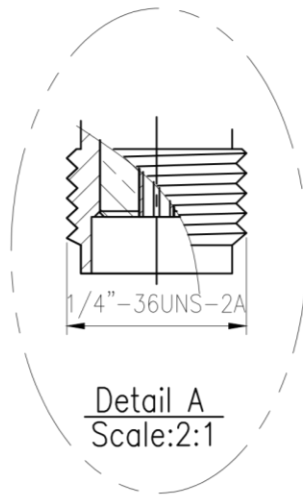

Top View

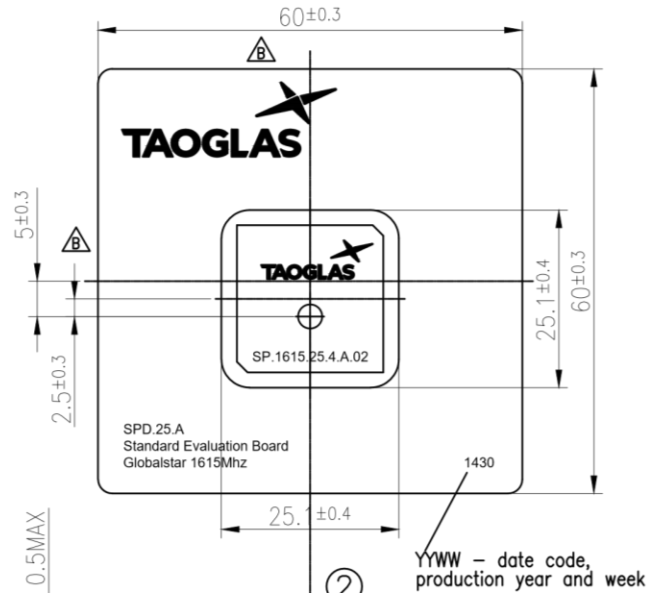

Side View

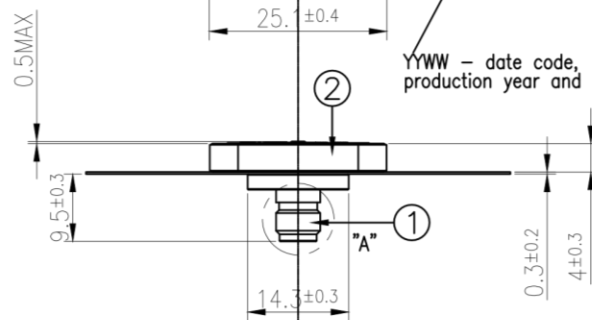

bottom View

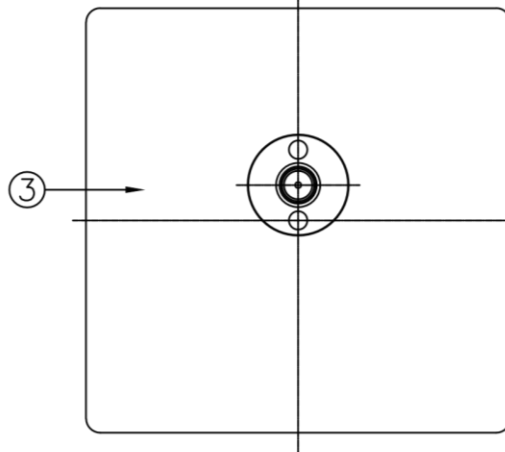

	Name	P/N	Material	Finish	QTY
1	SMA(F) ST	200413L000007A	Brass	Au Plated	1
2	SP.1615.25 Patch	001514F010007A	Ceramic	Clear	1
3	Brass Ground-Plane	000514F030007A	Brass	Silver	1

## 9. Recommended Reflow Soldering Profile

SGGP.12 can be assembled following Pb-free assembly. According to the Standard IPC/JEDEC J-STD-020C, the temperature profile suggested is as follows:

Phase	Profile Features	Pb-Free Assembly (SnAgCu)
Preheat	Temperature Min( $T_{smin}$ )	150°C
	Temperature Max( $T_{smax}$ )	200°C
	Time( $t_s$ ) from ( $T_{smin}$ to $T_{smax}$ )	60-120 seconds
Ramp-up	Avg. Ramp-up Rate ( $T_{smax}$ to $T_P$ )	3°C/second(max)
Reflow	Temperature( $T_L$ )	217°C
	Total Time above $T_L$ ( $t_L$ )	30-100 seconds
PEAK	Temperature( $T_P$ )	260°C
	Time( $t_p$ )	2-5 seconds
RAMP-DOWN	Rate	3°C/second(max)
Time from 25°C to Peak Temperature		8 minutes max.
Composition of solder paste		96.5Sn/3Ag/0.5Cu
Solder Paste Model		SHENMAO PF606-P26

The graphic shows temperature profile for component assembly process in reflow ovens

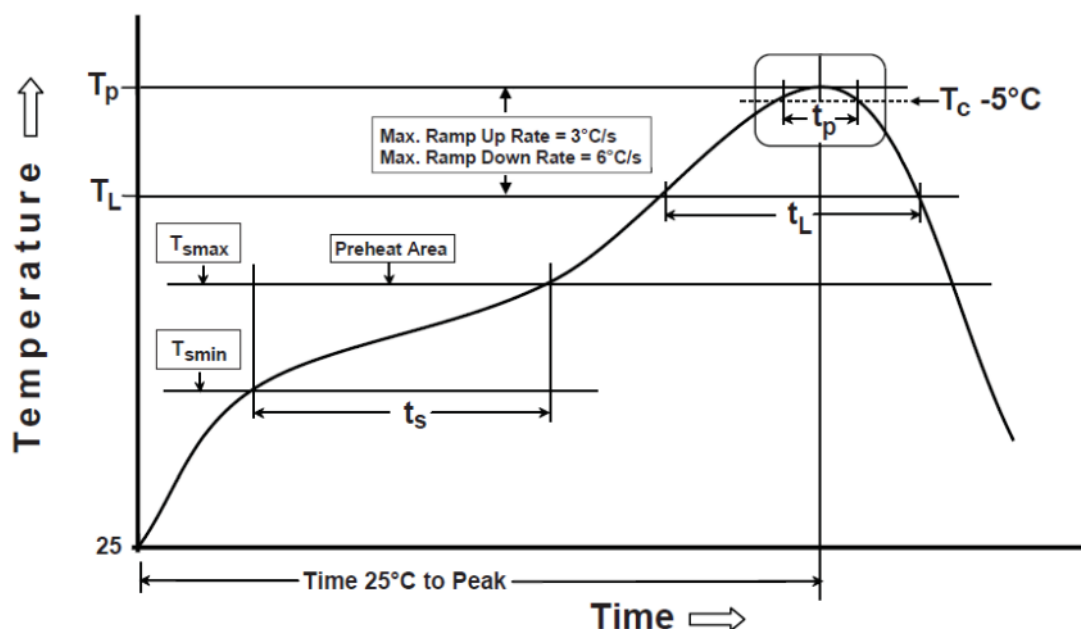

Soldering Iron condition: Soldering iron temperature  $270^\circ\text{C} \pm 10^\circ\text{C}$ .

Apply preheating at  $120^\circ\text{C}$  for 2-3 minutes. Finish soldering for each terminal within 3 seconds, if soldering iron temperature over  $270^\circ\text{C} \pm 10^\circ\text{C}$  for 3 seconds, it may cause component surface peeling or damage.

## 10. Packaging

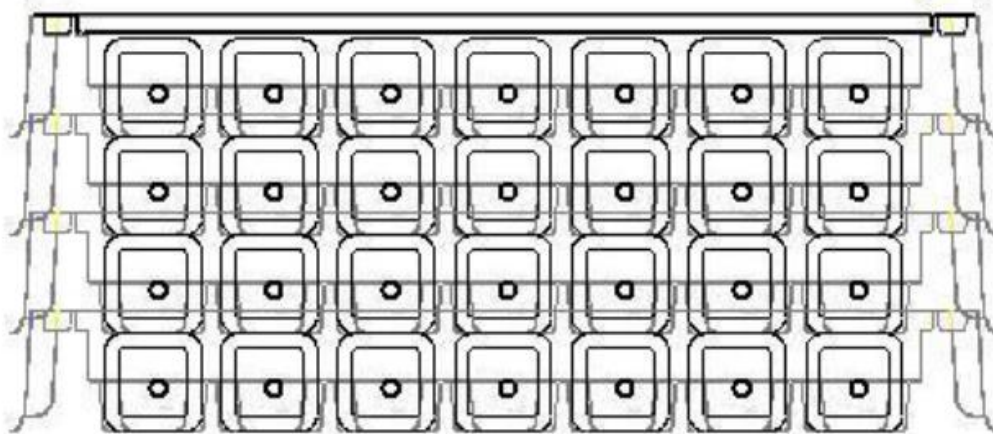
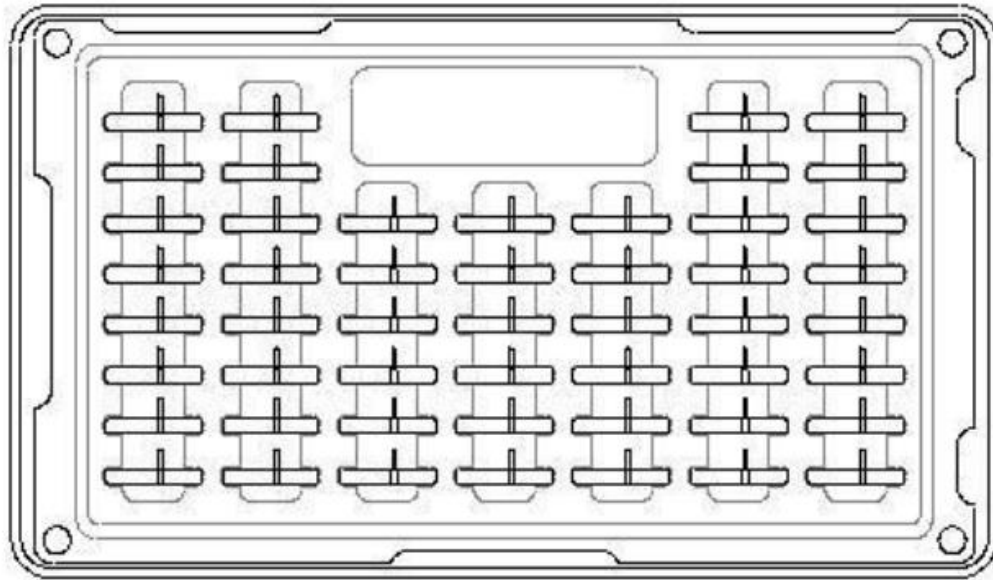

50 pieces per tray  
 200 pieces per inner carton  
 800 pieces per outer carton

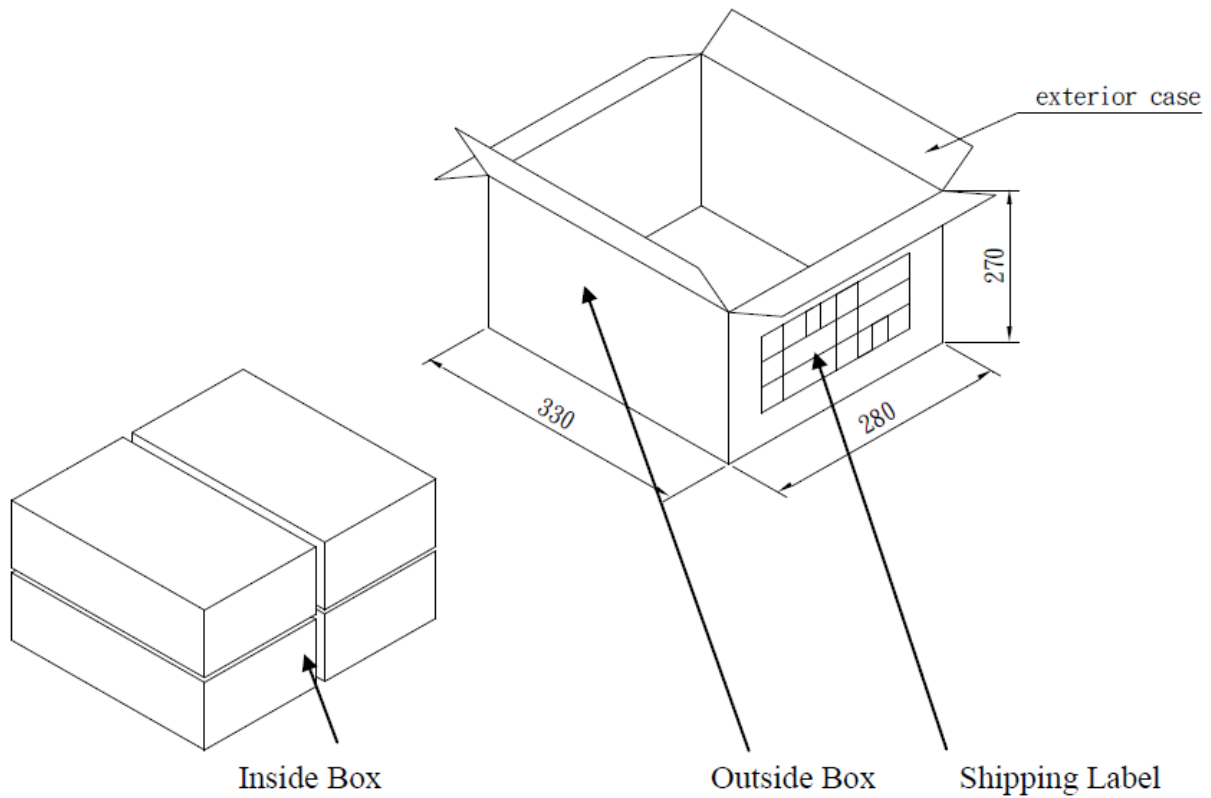
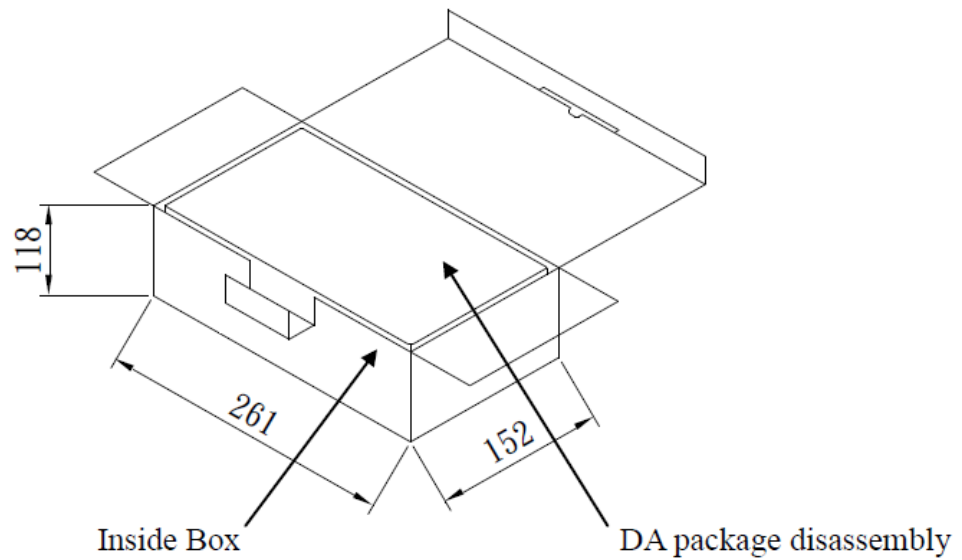

Taoglas makes no warranties based on the accuracy or completeness of the contents of this document and reserves the right to make changes to specifications and product descriptions at any time without notice. Taoglas reserves all rights to this document and the information contained herein.

Reproduction, use or disclosure to third parties without express permission is strictly prohibited.

Copyright © Taoglas Ltd

Changelog for the datasheet

**SPE-14-8-104-E- SP.1615.25.4.A.02**

Revision: C (Current Version)	
Date:	2023-03-16
Changes:	Antenna Integration Guide Added
Changes Made by:	Cesar Sousa

**Previous Revisions**

Revision: B	
Date:	2022-06-30
Changes:	Updated specification
Changes Made by:	Cesar Sousa

Revision: A (Original First Release)	
Date:	2016-05-01
Notes:	First Release
Author:	MC