

Enhanced RS-232 Line Drivers/Receivers

FEATURES

- Operates from a Single +5V Power Supply
- Meets all RS-232F and ITU V.28 Specifications
- Operates with 0.1 μ F Ceramic Capacitors
- No External Capacitors required (SP233A)
- Low Power Shutdown (SP310A, SP312A)
- High Data Rate - 120kbps under load
- Low power CMOS Operation
- +/-2kV Human Body Model ESD Protection
- Lead Free packaging available

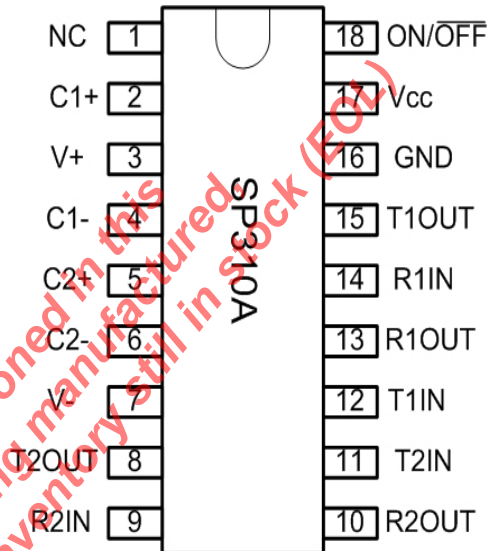

DESCRIPTION

The SP233A / SP310A / SP312A devices are a family of line driver and receiver pairs that meets the specifications of RS-232 and V.28 serial protocols. The devices are pin-to-pin compatible with popular industry standard pinouts. The SP233A / SP310A / SP312A offer 120kbps data rate under load, small ceramic type 0.1 μ F charge pump capacitors and overall ruggedness for commercial applications. Features include Exar's BiCMOS design allowing for low power operation without sacrificing performance. These devices are available in plastic DIP and SOIC Wide packages operating over the commercial and industrial temperature ranges.

SELECTION TABLE

Model	Number of RS-232		No. of RX active in Shutdown	No. of External 0.1 μ F Capacitors	Shutdown	WakeUp	TTL Tri-State
	Drivers	Receivers					
SP233A	2	2	N/A	0	No	No	No
SP310A	2	2	0	4	Yes	No	Yes
SP312A	2	2	2	4	Yes	Yes	Yes

SP310A and SP312A are obsolete

ABSOLUTE MAXIMUM RATINGS

These are stress ratings only and functional operation of the device at these ratings or any other above those indicated in the operation sections of the specifications below are not implied. Exposure to absolute maximum ratings conditions for extended periods of time may affect reliability.

Supply Voltage (V_{CC}).....+ 6V	Short Circuit duration
$V+$ ($V_{CC}-0.3V$) to +11.0V	T_{out}Continuous
$V-$-11.0V	Package Power Dissipation:
Input Voltages	Plastic DIP.....375mW
T_{in}-0.3V to ($V_{CC} + 0.3V$)	(derate 7mW/°C above +70°C)
R_{in}+/-30V	Small Outline.....375mW
Output Voltages	(derate 7mW/°C above +70°C)
T_{out}($V+$, +0.3V) to ($V-$, -0.3V)	Storage Temperature.....-65°C to +150°C
R_{out}-0.3V to ($V_{CC} + 0.3V$)	Lead Temperature (soldering, 10s)..... +300°C

ELECTRICAL CHARACTERISTICS

$V_{CC}=5V \pm 10\%$, 0.1 μF charge pump capacitors, T_{MIN} to T_{MAX} , unless otherwise noted. Typical values are $V_{CC}=5V$ and $T_A=25^\circ C$

PARAMETER	TEST CONDITIONS	MIN	TYP	MAX	UNIT
TTL INPUT					
Logic Threshold LOW	$T_{IN}, \overline{EN}, \overline{SD}, ON/OFF$			0.8	Volts
Logic Threshold HIGH	$T_{IN}, \overline{EN}, \overline{SD}, ON/OFF$	2.0			Volts
Logic Pull-Up Current	$T_{IN} = 0V$		15	200	μA
TTL OUTPUT					
Output Voltage LOW	$I_{OUT} = 3.2mA; V_{CC} = +5V$			0.4	Volts
Output Voltage HIGH	$I_{OUT} = -1.0mA$	3.5			Volts
Leakage Current; $T_A=25^\circ C$	$\overline{EN} = V_{CC}, 0V \leq V_{OUT} \leq V_{CC}$ SP310A and SP312A only		0.05	+/-10	μA
RS-232 OUTPUT					
Output Voltage Swing	All Transmitter outputs loaded with 3k ohms to GND	+/-5.0	+/-9V		Volts
Output Resistance	$V_{CC} = 0V, V_{out} = +/-2V$	300			Ohms
Output Short Circuit Current	Infinite Duration		+/-18		mA
Maximum Data Rate	$CL = 2500pF, RL = 3k\Omega$	120	240		kbps
RS-232 INPUT					
Voltage Range		-25		+25	Volts
Voltage Threshold LOW	$V_{CC} = 5V, T_A=25^\circ C$	0.8	1.2		Volts
Voltage Threshold HIGH	$V_{CC} = 5V, T_A=25^\circ C$		1.7	2.4	Volts
Hysteresis	$V_{CC} = 5V, T_A=25^\circ C$	0.2	0.5	1.0	Volts
Resistance	$T_A=25^\circ C, -25V \leq V_{IN} \leq +25V$	3	5	7	k Ω

ELECTRICAL CHARACTERISTICS

V_{cc}=5V ±10%, 0.1µF charge pump capacitors, T_{MIN} to T_{MAX}, unless otherwise noted, Typical values are V_{cc}=5V and T_A=25°C

Parameter	TEST CONDITIONS	MIN	TYP	MAX	Unit
DYNAMIC CHARACTERISTICS					
Driver Propagation Delay	TTL to RS_232; CL = 50pF		1.5	3.0	µs
Receiver Propagation Delay	RS-232 to TTL,		0.1	1.0	µs
Instantaneous Slew Rate	CL = 10pF, RL = 3-7kΩ			30	V/ µs
Transition Region Slew Rate	CL = 2500pF, RL = 3kΩ; Measured from +3V to -3V or -3V to +3V		10		V/ µs
Output Enable Time	SP310A and SP312A only		400		ns
Output Disable Time	SP310A and SP312A only		250		ns
POWER REQUIREMENTS					
V _{cc} Power Supply Current	No Load, V _{cc} = 5V, T _A =25°C		10	15	mA
V _{cc} Power Supply Current, Loaded	All Transmitters RL = 3kΩ, T _A =25°C		25		mA
Shutdown Supply Current SP310A and SP312A only	V _{cc} = 5V, T _A =25°C		1	10	µA

PIN ASSIGNMENTS

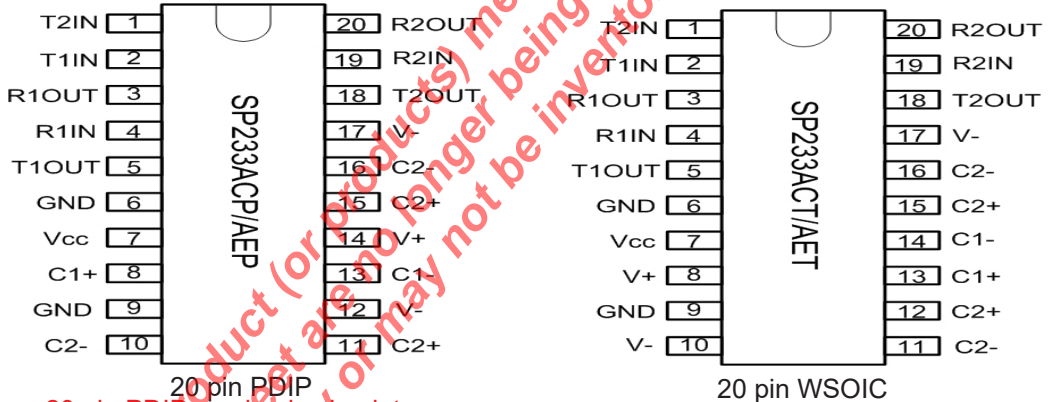

20 pin PDIP version is obsolete

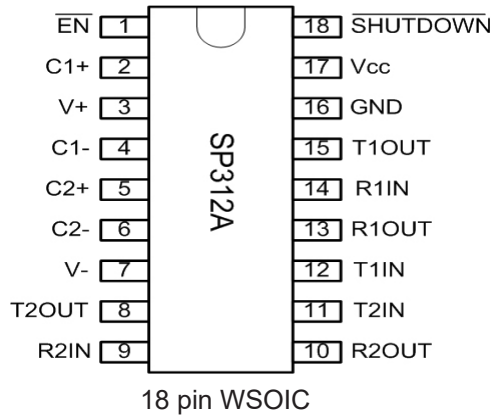
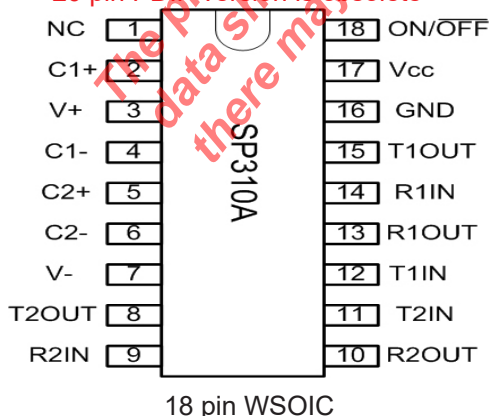

SP310A and SP312A are obsolete

DETAILED DESCRIPTION

The SP233A, SP310A and SP312A devices are a family of line driver and receiver pairs that meet the EIA/TIA-232 and V.28 serial communication protocols. These devices are pin-to-pin compatible with popular industry standards. The SP233A, SP310A and SP312A devices offer a 120kbps data rate, 10V/ μ s slew rate and an on-board charge pump that operates from a single 5V supply using 0.1 μ F ceramic capacitors. The ESD tolerance has been improved on these devices to +/-2kV Human Body Model.

The SP233A device provides internal charge pump capacitors. The SP310A provides an ON/OFF input that simultaneously disables the internal charge pump circuit and puts all transmitter and receiver outputs into a high impedance state. The SP312A is identical to the SP310 but with separate tri-state and shutdown inputs

Theory Of Operation

The SP233A, SP310A and SP312A devices are made up of three basic circuit blocks: 1. Drivers, 2. Receivers, and 3. charge pump.

Drivers

The drivers are inverting level transmitters that convert TTL or CMOS logic levels to EIA/TIA-232 levels with an inverted sense relative to the input logic levels. Typically, the driver output voltage swing is +/-9V. Even under worst case loading conditions of 3k ohms and 2500pF, the driver output is guaranteed to be +/-5.0V minimum, thus satisfying the RS-232 specification. The driver outputs are protected against infinite short-circuits to ground without degradation in reliability.

The drivers can guarantee output data rates of 120kbps under worst case loading of 3k ohms and 2500pF.

The Slew rate of the driver output is internally limited to 30V/ μ s in order to meet the EIA standards (EIA-232F). Additionally, the driver outputs LOW to HIGH transition meets the monotonic output requirements of the standard.

Receivers

The receivers convert EIA/TIA-232 signal levels to TTL or CMOS logic output levels. Since the input is usually from a transmission line, where long cable length and system interference can degrade the signal, the inputs have a typical hysteresis margin of 500mV. This ensures that the receiver is virtually immune to noisy transmission lines. Should an input be left unconnected, an internal 5kohm pull-down resistor to ground will commit the output of the receiver to a HIGH state.

Charge pump

The charge pump is a patented design and uses a unique approach compared to older less efficient designs. The charge pump requires 4 external capacitors and uses a four phase voltage shifting technique. The internal power supply consists of a dual charge pump that provides a driver output voltage swing of +/-9V. The internal oscillator controls the four phases of the voltage shifting. A description of each phase follows:

Phase 1

Vss charge store and double: The positive terminals of capacitors C1 and C2 are charged from Vcc with their negative terminals initially connected to ground. C1+ is then connected to ground and the stored charge from C1- is superimposed onto C2-. Since C2+ is still connected to Vcc the voltage potential across C2 is now 2 x Vcc.

Phase 2

Vss transfer and invert: Phase two connects the negative terminal of C2 to the Vss storage capacitor and the positive terminal of C2 to ground. This transfers the doubled and inverted (V-) voltage onto C4. Meanwhile, capacitor C1 is charged from Vcc to prepare it for its next phase.

Phase 3

Vdd charge store and double: Phase three is identical to the first phase. The positive terminals of C1 and C2 are charged from Vcc with their negative terminals initially connected to ground. C1+ is then connected to ground and the stored charge from C1- is superimposed onto C2-. Since C2+ is still connected to Vcc the voltage potential across capacitor C2 is now 2 x Vcc.

Phase 4

Vdd transfer: The fourth phase connects the negative terminal of C2 to ground and the positive terminal of C2 to the Vdd storage capacitor. This transfers the doubled (V+) voltage onto C3. Meanwhile, capacitor C1 is charged from Vcc to prepare it for its next phase.

The clock rate for the charge pump typically operates at greater than 15kHz allowing the pump to run efficiently with small 0.1uF capacitors. Efficient operation depends on rapid charging and discharging of C1 and C2, therefore capacitors should be mounted as close as possible to the IC and have low ESR (equivalent series resistance). Inexpensive surface mount, ceramic capacitors are ideal for using on charge pump. If polarized capacitors are used the positive and negative terminals should be connected as shown in the typical operating circuit. A diagram of the individual phases are shown in Figure 1.

Shutdown (\overline{SD}) and Enable (\overline{EN}) features for the SP310A and SP312A

Both the SP310A and SP312A have a shutdown / standby mode to conserve power in battery-powered applications. To activate the shutdown mode, which stops the operation of the charge pump, a logic "0" is applied to the appropriate control line. For the SP310A, this control line is the ON/OFF (pin 18) input. Activating the shutdown mode puts the SP310A transmitter and receiver outputs into a high impedance condition. For the SP312A, this control line is the SHUT-DOWN (pin18) input; this also puts the transmitter outputs in a tri-state mode. The receiver outputs can be tri-stated separately during normal operation or shutdown by applying a logic "1" on the \overline{EN} line (pin 1).

Wake-Up Feature for the SP312A

The SP312A has a wake-up feature that keeps the receivers active when the device is placed into shutdown. Table 1 defines the truth table for the Wake-Up function. When only the receivers are activated, the SP312A typically draws less than 5uA supply current. In the case of when a modem is interfaced to a computer in power down mode, the Ring Indicator (RI) signal from the modem would be used to "wake-up" the computer, allowing it to accept data transmission.

After the ring indicator has propagated through the SP312A receiver, it can be used to trigger the power management circuitry of the computer to power up the microprocessor, and bring the \overline{SD} pin of the SP312A to a logic high, taking it out of the shutdown mode. The receiver propagation delay is typically 1us. The enable time for V+ and V- is typically 2ms. After V+ and V- have settled to their final values, a signal can be sent back to the modem on the data terminal ready (DTR) pin signifying that the computer is ready to accept the transmit data.

\overline{SD}	\overline{EN}	Power Up/Down	Receiver outputs
0	0	Down	Enabled
0	1	Down	Tri-state
1	0	Up	Enabled
1	1	Up	Tri-state

Table 1. Wake-up Function truth table

Pin Strapping for the SP233ACT/ACP

The SP233A packaged in a 20 pin SOICW package (SP233ACT) has a slightly different pinout than the SP233A in PDIP packaging (SP233ACP). To operate properly, the following pairs of pins must be externally wired together as noted in table 2:

Pins Wired Together	SOICW	PDIP
Two V- pins	10 & 17	12 & 17
Two C2+ pins	12 & 15	11 & 15
Two C- pins	11 & 16	10 & 16
	No Connections for Pins 8, 13 and 14	
	Connect Pins 6 and 9 to GND	

Table 2. Pin Strapping table for SP233A

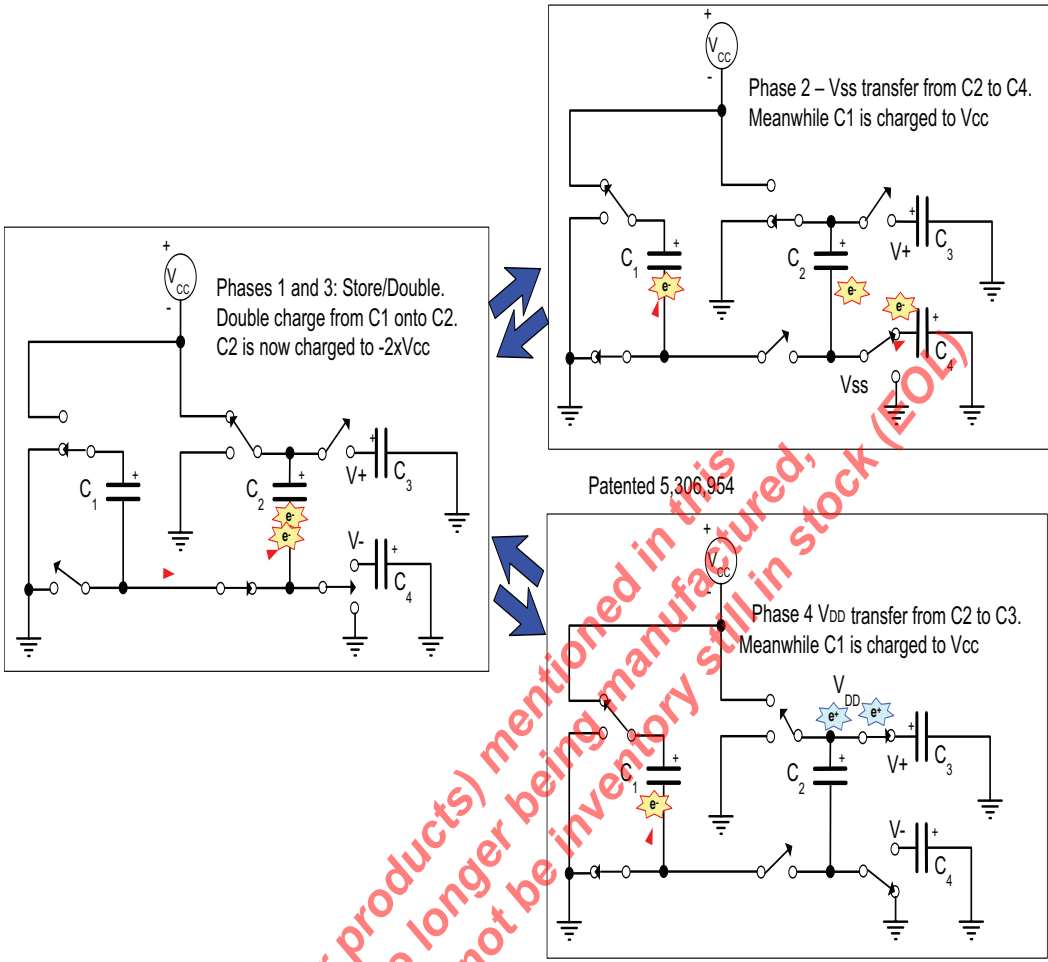

Figure 1. Charge pump phases

The product (or products) mentioned in this data sheet are no longer being manufactured, there may or may not be inventory still in stock (FOL)

TYPICAL PERFORMANCE CHARACTERISTICS

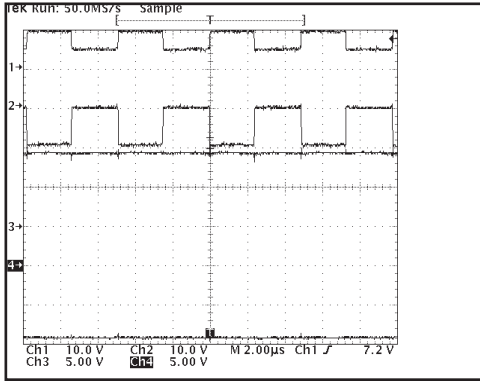

Figure 2, SP233A Charge pump waveforms-no load (1 = C1+, 2 = C2+, 3 = V+, 4 = V-).

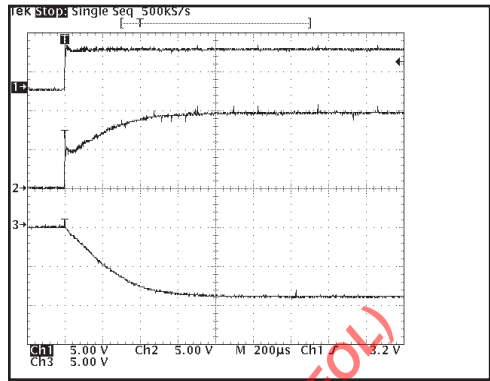

Figure 5, Charge pump outputs at start up (1 = Vcc, 2 = V+, 3 = V-).

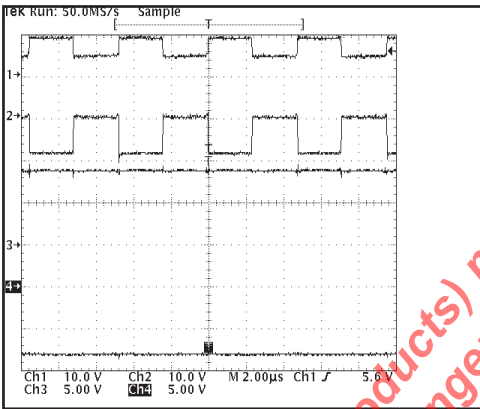

Figure 3, SP233A Charge pump waveforms when fully loaded with 3Kohms (1 = C1+, 2 = C2+, 3 = V+, 4 = V-).

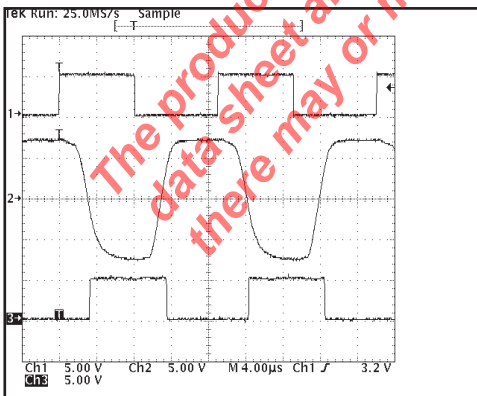

Figure 4, Loopback results at 60KHZ and 2500pF load (1 = TXin, 2 = TXout/RXin, 3 = RXout).

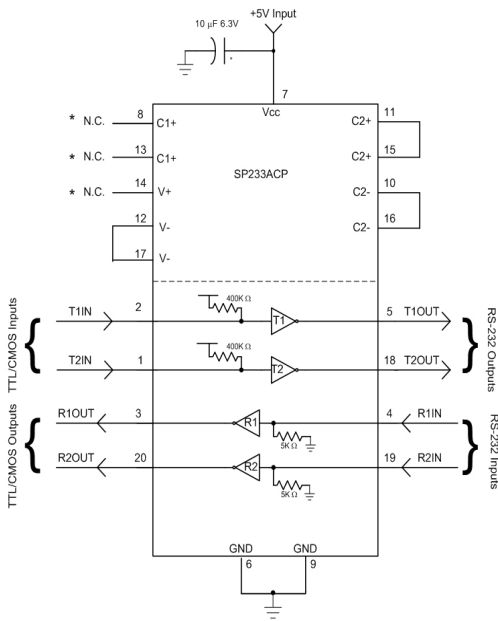

Figure 6, SP233ACP Typical Application circuit

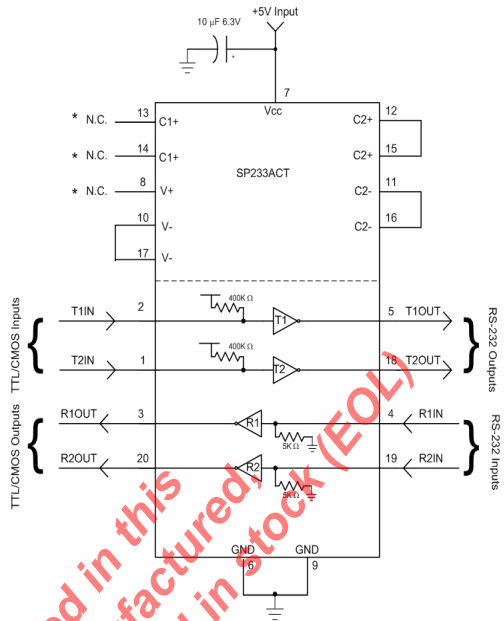

Figure 8, SP233ACT Typical Application circuit

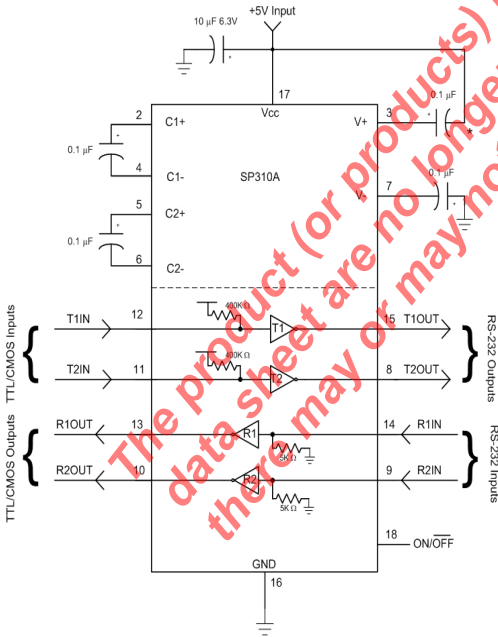

Figure 7, SP310A Typical Application circuit

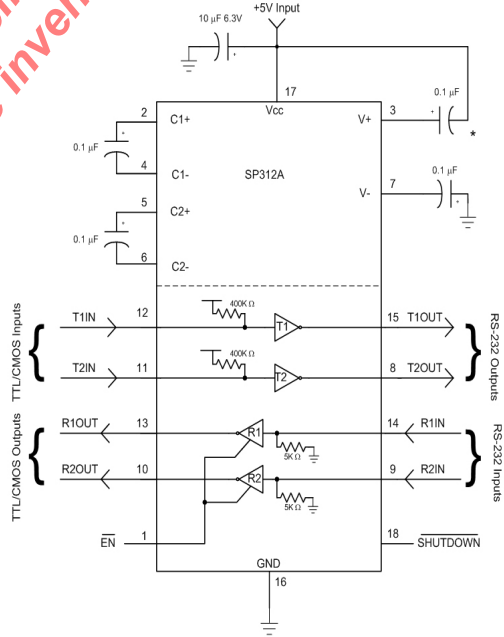
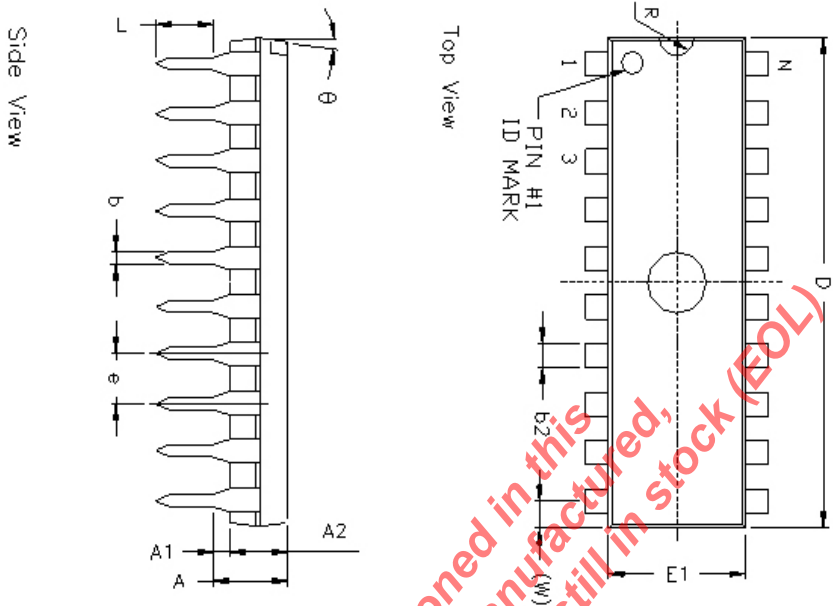

Figure 9, SP312A Typical Application circuit

20 pin PDIP version is obsolete



REMARKS:
FOR 8LD AND 16LD
ALL END LEADS (4X)
ARE HALF LEAD TYPES

The product (or products) mentioned in this data sheet are no longer being manufactured, there may or may not be inventory still in stock (FOL)

20 Pin PDIP JEDEC MS-001 Variation AD		REVISION HISTORY				
SYMBOLS	DIMENSIONS IN INCH (Control Unit)		DIMENSIONS IN MM (Reference Unit)		DATE	APPRO
	MIN	NOM	MIN	NOM		
A	—	0.210	—	—	5.33	—
A1	0.015	—	0.38	—	—	—
A2	0.115	0.130	0.195	2.92	3.30	4.95
b	0.014	0.018	0.022	0.36	0.46	0.56
b2	0.045	0.060	0.070	1.14	1.52	1.78
c	0.008	0.010	0.014	0.20	0.25	0.36
D1	0.030	—	0.060	0.76	—	1.52
E	0.300	0.310	0.325	7.62	7.62	8.26
E1	0.240	0.250	0.280	6.10	6.35	7.11
e	—	0.100 BSC	—	—	2.54 BSC	—
eA	—	0.300 BSC	—	—	7.62 BSC	—
eB	—	—	0.430	—	—	10.92
L	0.115	0.130	0.150	2.92	3.30	3.81
W	—	0.075 REF	—	—	1.91 REF	—
R	—	0.030 BSC	—	—	0.76 BSC	—
theta	4°	7°	10°	4°	7°	10°
D	0.980	1.030	1.060	24.89	26.16	26.92
N	20	20	20	20	20	20



EXAR CORPORATION
Precision Connectivity

Packaging Approval:		Drawing No:	
by JL	date 11/27/07	B	20-PIN PDIP
Revision: B		Sheet: 1 OF 1	

REVISION HISTORY			
REV.	DESCRIPTION	DATE	APP'D.
A	DRAWING ORIENTATION	04/24/06	JL
B	CHANGE DRAWING LOGO AND COMPANY NAME	11/28/07	JL

20 Pin SOICW JEDEC MS-013 Variation AC				
SYMBOLS	DIMENSIONS IN MM (Control Unit)		DIMENSIONS IN INCH (Reference Unit)	
	MIN	NOM	MIN	MAX
A	2.35	—	2.65	0.093
A1	0.10	—	0.30	0.004
A2	2.05	—	2.55	0.081
b	0.31	—	0.51	0.012
c	0.20	—	0.33	0.008
E	10.30	BSC	—	0.406 BSC
E1	7.50	BSC	—	0.295 BSC
e	0.25	—	0.75	0.010
L	0.40	—	1.27	0.016
L1	1.40	REF	—	0.055 REF
L2	0.25	BSC	—	0.010 BSC
R	0.07	—	0.0013	—
R1	0.07	—	0.003	—
θ	0°	—	8°	0°
θ1	5°	—	15°	5°
θ2	0°	—	0°	—
D	12.80	BSC	—	0.504 BSC
h	20	—	—	20

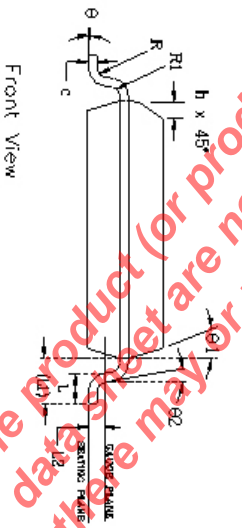
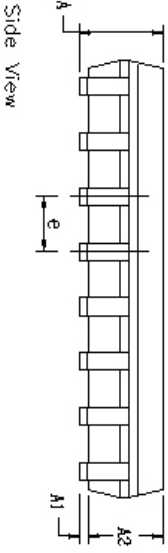
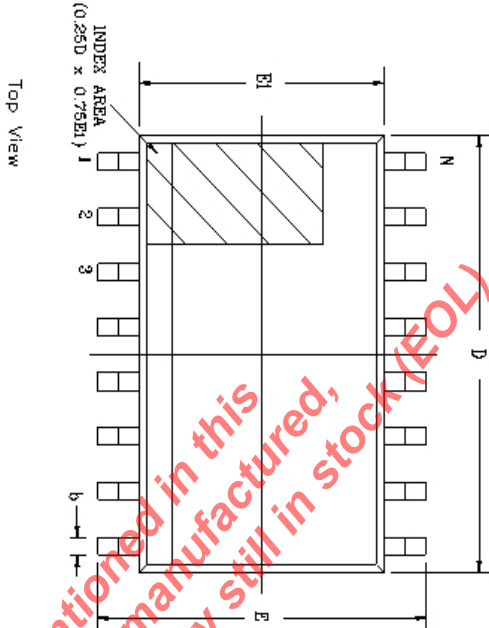

		EXAR CORPORATION	
		20 PIN SOICW PACKAGE OUTLINE	
Packaging Approval:	11/28/07	Drawing No:	20-PIN SOICW
By: JL	Date:	Revision:	B
		Sheet:	1 OF 1

The product (or products) mentioned in this drawing sheet are no longer being manufactured, the data in this sheet may or may not be inventory still in stock (EOL)

SP310A and SP312A WSOIC18 are obsolete

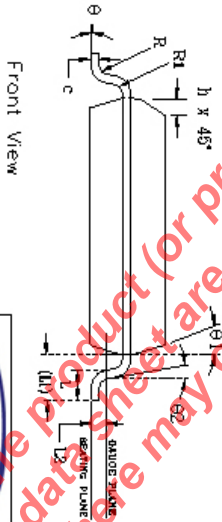
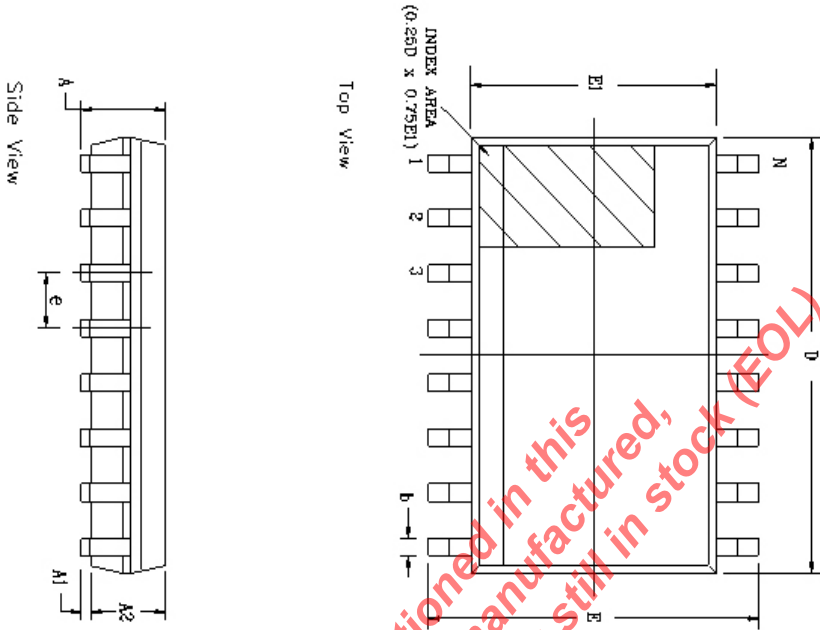

18 Pin SOICW		JEDEC MS-013		Version AB	
SYMBOLS	DIMENSIONS IN MM (Control Unit)		DIMENSIONS IN INCH (Reference Unit)		
	MIN	MAX	MIN	MAX	
A	2.35	2.65	0.093	0.104	
A1	0.10	0.30	0.004	0.012	
A2	2.05	2.55	0.081	0.100	
b	0.31	0.51	0.012	0.020	
c	0.20	0.33	0.008	0.013	
E	10.30	B9C	0.406	B9C	
E1	7.50	B9C	0.295	B9C	
b	1.27	B9C	0.050	B9C	
h	0.25	0.75	0.010	0.030	
L	0.40	1.27	0.016	0.050	
L1	1.40	REF	0.055	REF	
L2	0.25	B9C	0.010	B9C	
R	0.07	—	0.003	—	
R1	0.07	—	0.003	—	
theta	0°	8°	0°	8°	
theta1	5°	15°	5°	15°	
theta2	0°	—	0°	—	
D	11.55	B9C	0.455	B9C	
N	18		18		

REVISION HISTORY		DATE	APP'D
REV.	DESCRIPTION		
A	DRAWING ORIGINATOR	04/24/08	JL
B	CHANGE DRAWING LOGO AND COMPANY NAME	11/21/07	JL

EXAR CORPORATION

18 PIN SOICW PACKAGE OUTLINE

Packaging Approval:	Drawing No:	Revision:	Sheet:
By: JL Date: 11/21/07	18-PIN SOICW	B	1 OF 1

The product (or products) mentioned in this data sheet are no longer being manufactured, there may or may not be inventory still in stock (EOL)