

GENERAL DESCRIPTION

The SP336E is a monolithic serial multi-transceiver device that contains both RS-232 and RS-485/RS-422 line drivers and receivers. The configuration of the SP336E can be reconfigured into eight operating modes including RS-232 only (4TX/4RX), RS-485/RS-422 only (2TX/2RX) full or half duplex, two RS-232/RS-485 mixed modes, two shutdown modes and a diagnostic loop-back mode. Modes may be selected at any time by changing the logic state of the three MODE pins. The device can implement a dual-mode serial port, mixed mode ports or as an interface signal translator. The MaxLinear charge pumps deliver true RS-232 driver output voltages from a single power supply at either 3.3V or 5V. The SP336E requires only four 0.1 μ F capacitors for charge pump. A slew rate control pin configures driver outputs for either high data rate or slew-controlled data rates. Slew-controlled outputs minimize problems with reflections and ringing on long or un-terminated cables. All RS-485 receivers or transceivers feature high impedance which allow up to 256 transceivers on a shared bus. When configured in RS-485/RS-422 mode, each driver may be individually enabled or put into tri-state, simplifying use on shared buses or bidirectional communication. All receivers have advanced failsafe protection to prevent oscillation when inputs are un-connected. In RS-232 mode each receiver input has a 5k ohm pull-down to ground. Differential Receivers will default to output logic 1 if inputs are floating, shorted or open but terminated. All driver outputs and receiver inputs are protected against ESD strikes up to $\pm 15,000$ volts.

FEATURES

- 3.3V or 5V Single Supply Operation
- Robust ± 15 kV ESD Protection (IEC 61000-4-2 Air Gap)
- Software Selectable Mode Selection
- Up to 4 Drivers, 4 Receivers RS-232/V.28
- Up to 2 Drivers, 2 Receivers RS-485/RS-422
 - Full or Half Duplex Configurations
 - 1/8th Unit Load, up to 256 receivers on bus
- Mixed RS-232/RS-485 modes
- Pin Programmable Slew Rate for Reduced EMI
- RS-485 Advanced Failsafe on Open, Short or Terminated Lines
- Diagnostic Loop-Back Function
- 28 Pin SOIC or TSSOP Packaging

TYPICAL APPLICATIONS

- Factory Automation Equipment
- Security Networks
- Industrial/Process Control Networks
- Point-Of-Sales Equipment
- Gaming Machines
- Serial Protocol Translators (ex. RS-232 to RS-485/RS-422)
- Embedded Industrial PC's
- Building Environmental Control Systems (ex. HVAC)
- Cable Repeaters / Port Extenders / Hubs

FIGURE 1. TYPICAL RS-232 APPLICATION CIRCUIT

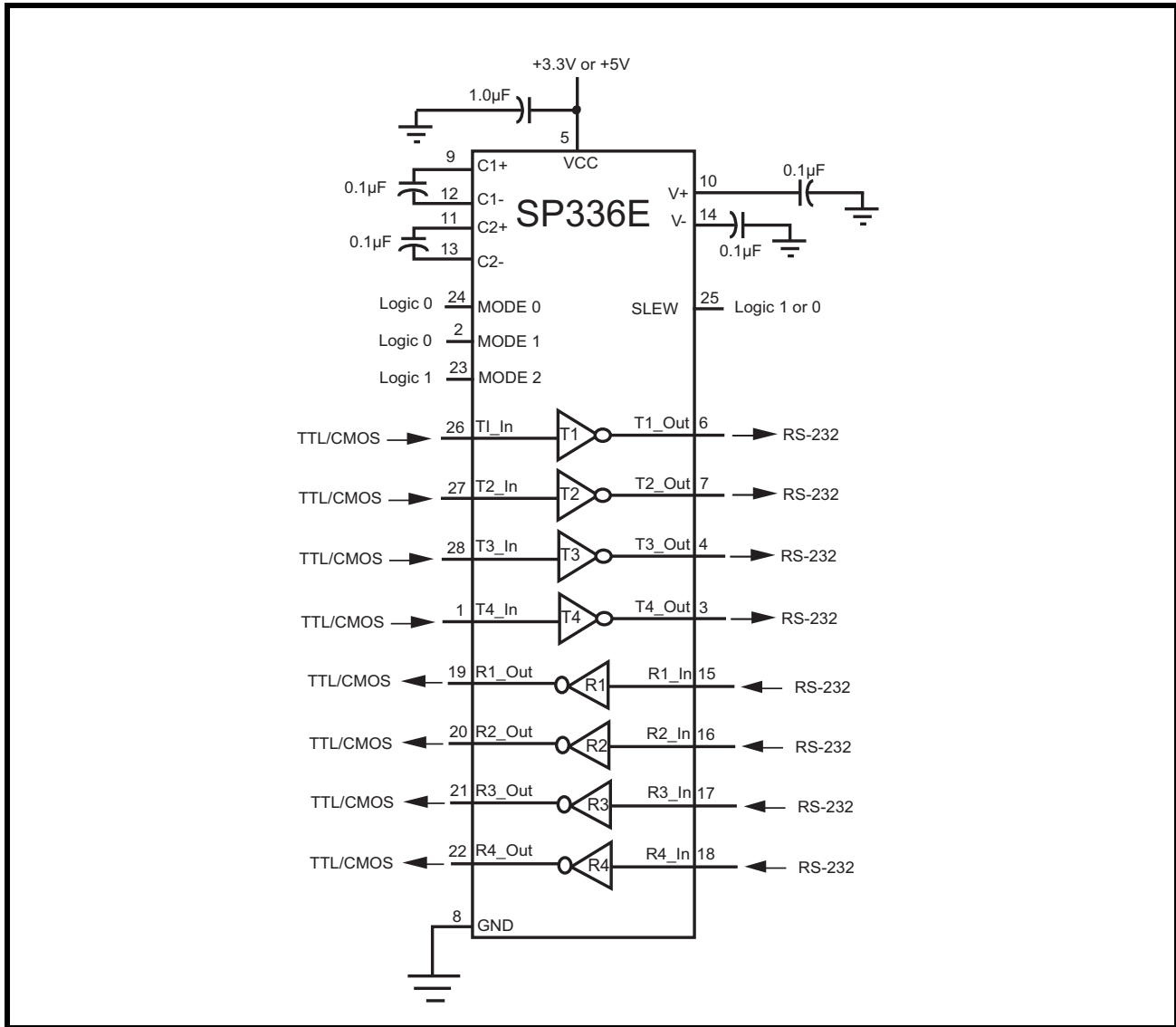
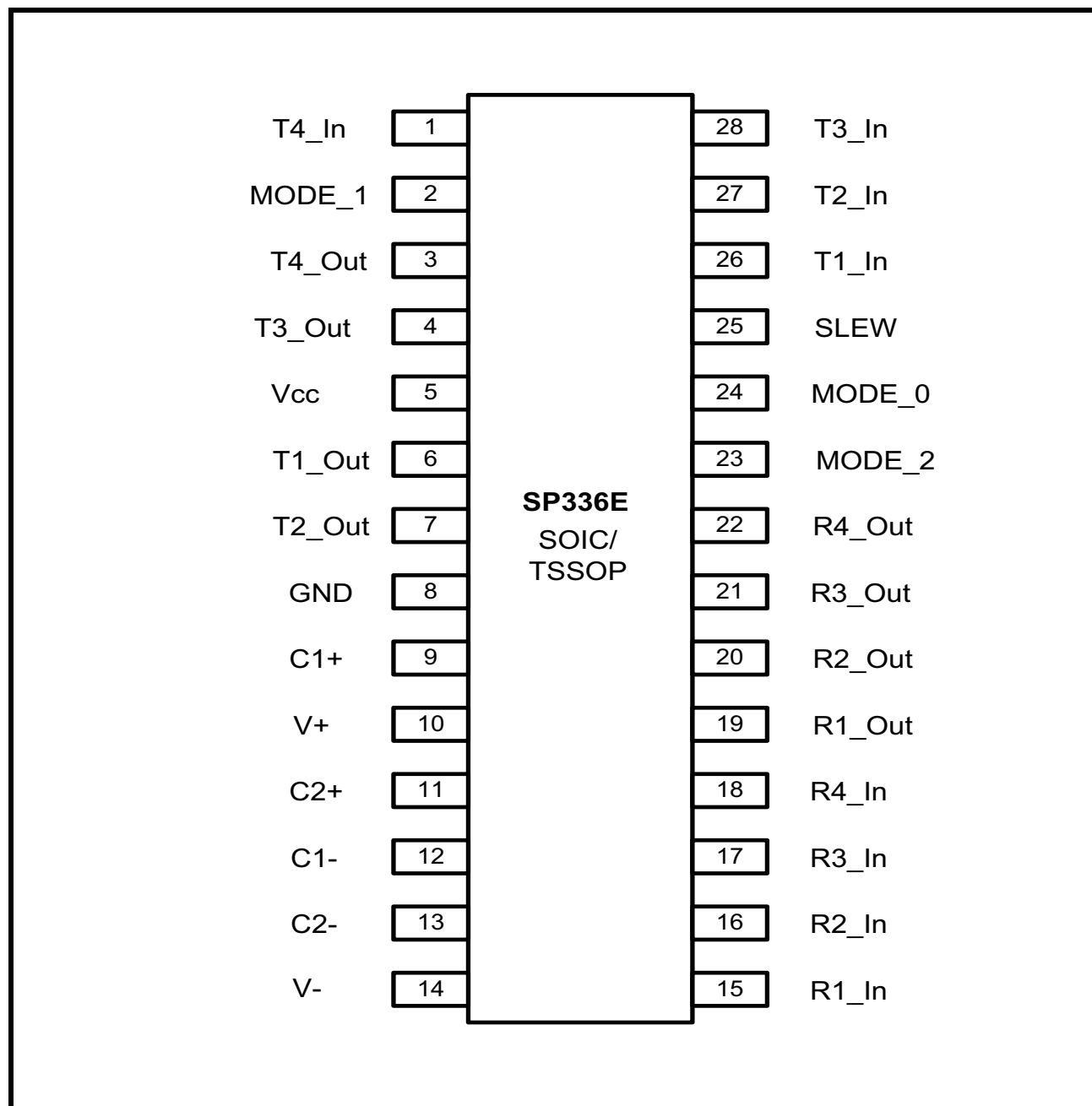

FIGURE 2. PIN OUT ASSIGNMENT

ORDERING INFORMATION⁽¹⁾

| PART NUMBER | OPERATING TEMPERATURE RANGE | LEAD-FREE | PACKAGE | PACKAGING METHOD |
|---------------|-----------------------------|--------------------|---------------|------------------|
| SP336ECT-L | 0°C to +70°C | Yes ⁽²⁾ | 28-pin SOIC-W | Tube |
| SP336ECY-L | 0°C to +70°C | | 28-pin TSSOP | Tube |
| SP336EET-L | -40°C to +85°C | | 28-pin SOIC-W | Tube |
| SP336EEY-L | -40°C to +85°C | | 28-pin TSSOP | Tube |
| SP336EEY-L/TR | | | | Tape and Reel |

NOTES:

1. Refer to www.exar.com/SP336E for most up-to-date Ordering Information.
2. Visit www.exar.com for additional information on Environmental Rating.

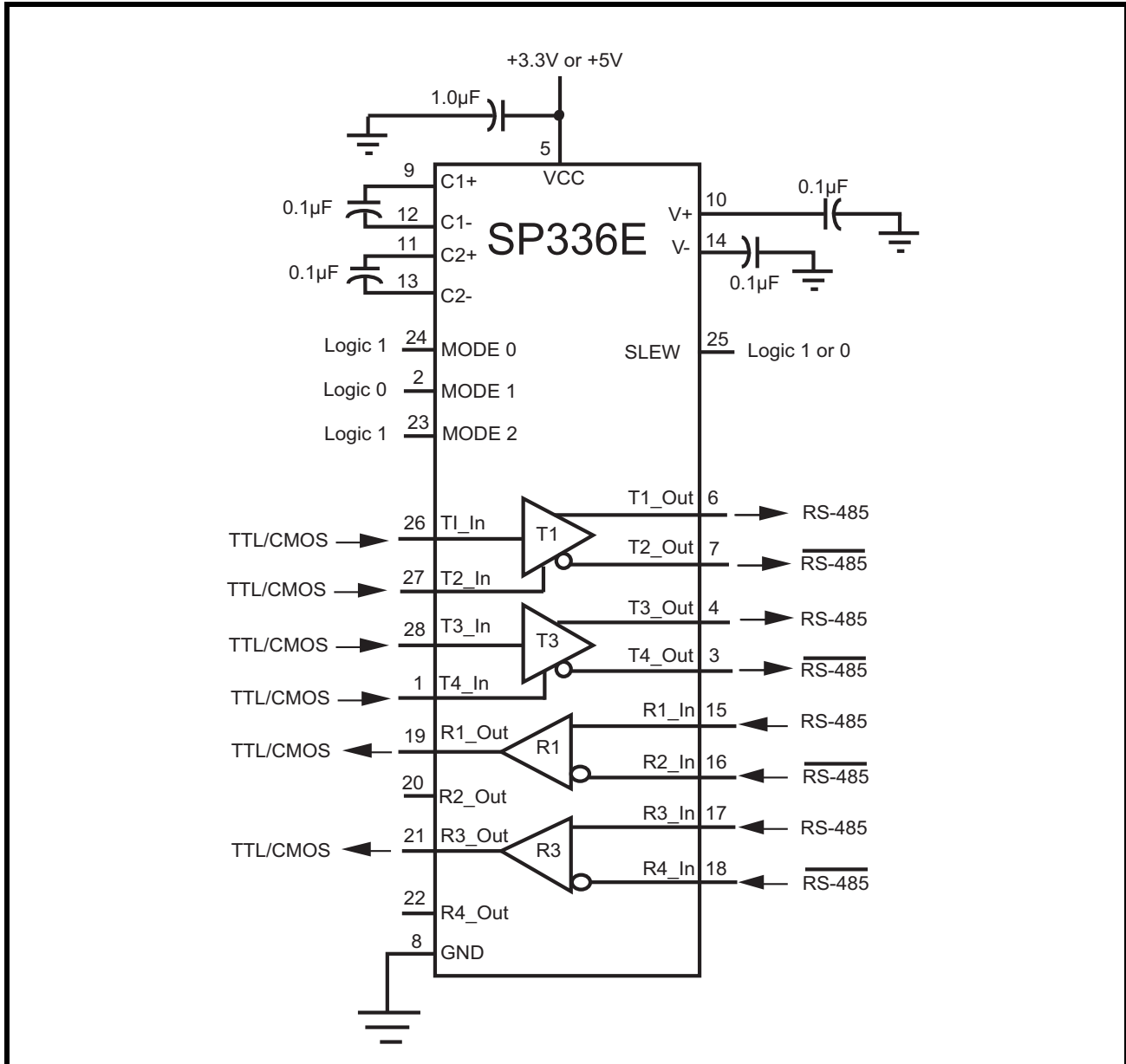
FIGURE 3. TYPICAL RS-485 APPLICATION CIRCUIT



PIN DESCRIPTIONS
Pin Assignments

| PIN NUMBER | PIN NAME | TYPE | DESCRIPTION | | |
|------------|----------|------|--|-------------------------------|---|
| | | | SINGLE ENDED | FULL-DUPLEX | HALF-DUPLEX |
| 1 | T4_In | I | T4 Driver TTL input. | T3 Driver Enable Active High. | T3 Driver Enable Active High, R3 Enable Active Low. |
| 2 | Mode_1 | I | Mode Configuration pin 1. | | |
| 3 | T4_Out | O | T4 Driver Output. | T3(B) Output. | T3(B) Output, R3(B) Input. |
| 4 | T3_Out | O | T3 Driver Output. | T3(A) Output. | T3(A) Output, R3(A) Input. |
| 5 | Vcc | Pwr | Power Supply Voltage. | | |
| 6 | T1_Out | O | T1 Driver Output. | T1(A) Output. | T1(A) Output, R1(A) Input. |
| 7 | T2_Out | O | T2 Driver Output. | T1(B) Output. | T1(B) Output, R1(B) Input. |
| 8 | GND | Pwr | Ground. | | |
| 9 | C1+ | Pmp | Positive terminal of positive flying capacitor. | | |
| 10 | V+ | Pmp | Vdd storage capacitor. | | |
| 11 | C2+ | Pmp | Positive terminal of negative flying capacitor. | | |
| 12 | C1- | Pmp | Negative terminal of positive flying capacitor. | | |
| 13 | C2- | Pmp | Negative terminal of negative flying capacitor. | | |
| 14 | V- | Pmp | Vss storage capacitor. | | |
| 15 | R1_In | I | R1 Receiver Input. | R1(A) Receiver Input. | High Impedance. |
| 16 | R2_In | I | R2 Receiver Input. | R1(B) Receiver Input. | R2 Receiver Input. |
| 17 | R3_In | I | R3 Receiver Input. | R3(A) Receiver Input. | High Impedance. |
| 18 | R4_In | I | R4 Receiver Input. | R3(B) Receiver Input. | R4 Receiver Input. |
| 19 | R1_Out | O | R1 Receiver Output. | | |
| 20 | R2_Out | O | R2 Receiver Output. | High Impedance. | R2 Receiver Output. |
| 21 | R3_Out | O | R3 Receiver Output. | | |
| 22 | R4_Out | O | R4 Receiver Output. | High Impedance. | R4 Receiver Output. |
| 23 | Mode_2 | I | Mode Configuration pin 2. | | |
| 24 | Mode_0 | I | Mode Configuration pin 0. | | |
| 25 | SLEW | I | Slew Rate Control. Logic Low input will limit driver slew from either RS-232 or RS-485 to 250kbps. | | |
| 26 | T1_In | I | T1 Driver Input. | | |

Pin Assignments

| PIN NUMBER | PIN NAME | TYPE | DESCRIPTION | | |
|------------|----------|------|------------------|-------------------------------|---|
| | | | SINGLE ENDED | FULL-DUPLEX | HALF-DUPLEX |
| 27 | T2_In | I | T2 Driver Input. | T1 Driver Enable Active High. | T1 Driver Enable Active High and R1 Receiver Enable Active Low. |
| 28 | T3_In | I | T3 Driver Input. | | |

Pin type: I=Input, O=Output, Pwr=Power supply, Pmp = Charge pump.

MODE CONFIGURATION

| OPERATION: | RS-232 MODE | MIXED-PROTOCOL FULL DUPLEX |
|-------------------|--------------|-----------------------------|
| | 4T/4R RS-232 | 2T/2R RS-232 & 1T/1R RS-485 |
| MODE (M0, M1, M2) | 001 | 011 |
| | | |

MODE CONFIGURATION (CONTINUED)

| OPERATION: | LOW POWER SHUTDOWN | RS-485/RS-422 FULL DUPLEX |
|-------------------|---------------------------|---------------------------|
| | ALL I/O AT HIGH IMPEDANCE | 2T/2R RS-485 |
| MODE (M0, M1, M2) | 111 | 101 |
| | | |

MODE CONFIGURATION (CONTINUED)

| OPERATION: | LOOP-BACK TXIN TO RXOUT | MIXED-PROTOCOL HALF DUPLEX |
|-------------------|-------------------------------|-----------------------------|
| | TXOUT AND RXIN HIGH IMPEDANCE | 2T/3R RS-232 & 1T/1R RS-485 |
| MODE (M0, M1, M2) | 000 | 010 |
| | | |

MODE CONFIGURATION (CONTINUED)

| OPERATION: | LOW POWER, 4 RX ACTIVE | RS-485/RS-422 HALF DUPLEX |
|-------------------|---------------------------|---------------------------|
| | DRIVERS AT HIGH IMPEDANCE | 2T/2R RS-485 & 2R RS-232 |
| MODE (M0, M1, M2) | 110 | 100 |
| | | |

ABSOLUTE MAXIMUM RATINGS

These are stress ratings only and functional operation of the device at these ratings or any other above those indicated in the operation sections to the specifications below is not implied. Exposure to absolute maximum rating conditions for extended periods of time may affect reliability and cause permanent damage to the device.

| | |
|---|--------------------------|
| Supply Voltage V_{CC} | +6.0V |
| Receiver Input V_{IN} (DC Input Voltage) | -15V to +15V |
| Input Voltage at TTL input Pins | -0.3V to $V_{CC} + 0.5V$ |
| Driver Output Voltage (from Ground) | -7.5V to +12.5V |
| Short Circuit Duration, TXout to GND | Continuous |
| Storage Temperature Range | -65°C to + 150°C |
| Lead Temperature (soldering, 10s) | +300°C |
| Power Dissipation 28-pin SOIC-W (derate 17mW/°C above +70°C) | 938mW |
| Power Dissipation 28-pin TSSOP (derate 12mW/°C above +70°C) | 657mW |
| ESD Ratings | |
| HBM - Human Body Model (Tx_Out & Rx_In Pins) | ±15kV |
| HBM - Human Body Model (all other pins) | ± 2kV |
| IEC 61000-4-2 Airgap Discharge (Tx_Out & Rx_In Pins) | ±15kV |
| IEC 61000-4-2 Contact Discharge (Tx_Out & Rx_In Pins) | ± 8kV |

CAUTION:

ESD (Electrostatic Discharge) sensitive device. Permanent damage may occur on unconnected devices subject to high energy electrostatic fields. Unused devices must be stored in conductive foam or shunts. Personnel should be properly grounded prior to handling this device. The protective foam should be discharged to the destination socket before devices are removed.

ELECTRICAL CHARACTERISTICS

UNLESS OTHERWISE NOTED: $V_{CC} = +3.3V \pm 5\%$ OR $+5.0V \pm 5\%$; $T_A = T_{MIN}$ TO T_{MAX} . TYPICAL VALUES ARE AT $V_{CC} = 3.3V$, $T_A = +25^\circ C$.

| SYMBOL | PARAMETERS | MIN. | TYP. | MAX. | UNITS | CONDITIONS |
|--|-----------------------------|------|------|------|-------|----------------------|
| DC CHARACTERISTICS | | | | | | |
| I_{CC} | Supply Current (RS-232) | | 2 | 30 | mA | No Load, MODE = 001. |
| I_{CC} | Supply Current (RS-485) | | 6.5 | 20 | mA | No Load, MODE = 101. |
| I_{CC} | V_{CC} Shutdown Current | | 1 | 20 | μA | MODE = 111. |
| TRANSMITTER and LOGIC INPUT PINS: Pins 1, 2, 23, 24, 25, 26, 27, 28 | | | | | | |
| V_{IH} | Logic Input Voltage HIGH | 2.0 | | | V | $V_{CC} = 3.3V$. |
| V_{IH} | Logic Input Voltage HIGH | 2.4 | | | V | $V_{CC} = 5.0V$. |
| V_{IL} | Logic Input Voltage LOW | | | 0.8 | V | |
| I_{IL} | Logic Input Pull-up Current | | | ±15 | μA | |
| V_{HYS} | Logic Input Hysteresis | | 0.5 | | V | |

UNLESS OTHERWISE NOTED: $V_{CC} = +3.3V \pm 5\%$ OR $+5.0V \pm 5\%$; $T_A = T_{MIN}$ TO T_{MAX} . TYPICAL VALUES ARE AT $V_{CC} = 3.3V$, $T_A = +25^{\circ}C$.

| SYMBOL | PARAMETERS | MIN. | TYP. | MAX. | UNITS | CONDITIONS |
|--|--|----------------|------------|-----------|-----------|---|
| RS-232 and RS-485/422 RECEIVER OUTPUTS: Pins 19, 20, 21, 22 | | | | | | |
| V_{OH} | Receiver Output Voltage HIGH | $V_{CC} - 0.6$ | | | V | $I_{OUT} = -1.5mA$. |
| V_{OL} | Receiver Output Voltage LOW | | | 0.4 | V | $I_{OUT} = 2.5mA$. |
| I_{OSS} | Receiver Output Short-Circuit Current | | ± 20 | ± 60 | mA | $0 < V_o < V_{CC}$. |
| I_{OZ} | Receiver Output Leakage Current | | ± 0.05 | ± 1 | μA | Receivers Disabled. |
| SINGLE-ENDED RECEIVER INPUTS (RS-232) | | | | | | |
| | Input Voltage Range | -15 | | +15 | V | |
| | Input Threshold Low | 0.6 | 1.2 | | V | $V_{CC} = 3.3V$. |
| | | 0.8 | 1.5 | | V | $V_{CC} = 5.0V$. |
| | Input Threshold HIGH | | 1.5 | 2.0 | V | $V_{CC} = 3.3V$. |
| | | | 1.8 | 2.4 | V | $V_{CC} = 5.0V$. |
| | Input Hysteresis | | 0.5 | | V | |
| | Input Resistance | 3 | 5 | 7 | $k\Omega$ | |
| DIFFERENTIAL RECEIVER INPUTS (RS-485 / RS-422) | | | | | | |
| R_{IN} | Receiver Input Resistance | 96 | | | $k\Omega$ | $-7V \leq V_{CM} \leq +12V$. |
| V_{TH} | Receiver Differential Threshold Voltage | -200 | -125 | -50 | mV | |
| ΔV_{TH} | Receiver Input Hysteresis | | 30 | | mV | $V_{CM} = 0V$. |
| I_{IN} | Input Current | | | 125 | μA | $DE = 0V$, $V_{IN} = 12V$, Full-Duplex. |
| | | | | -100 | μA | $DE = 0V$, $V_{IN} = -7V$, Full-Duplex. |
| SINGLE-ENDED DRIVER OUTPUTS (RS-232) | | | | | | |
| V_O | Output Voltage Swing | ± 5.0 | ± 5.4 | | V | Output Loaded with $3k\Omega$ to GND. |
| | | | | ± 6.6 | V | No Load Output. |
| | Short Circuit Current | | | ± 60 | mA | $V_O = 0V$. |
| | Power Off Impedance | 300 | 10M | | Ω | $V_{CC} = 0V$; $V_O = \pm 2V$. |
| DIFFERENTIAL DRIVER OUTPUTS (RS-485 / RS-422) | | | | | | |
| V_{OD} | Differential Driver Output (Tx_Out) | 2 | | V_{CC} | V | $R_L = 100\Omega$ (RS-422), Figure 4. |
| | | 1.5 | | V_{CC} | V | $R_L = 54\Omega$ (RS-485), Figure 4. |
| | | 1.5 | | V_{CC} | V | $V_{CM} = -7V$, Figure 5. |
| | | 1.5 | | V_{CC} | V | $V_{CM} = +12V$, Figure 5. |
| ΔV_{OD} | Change In Magnitude of Differential Output Voltage | -0.2 | | +0.2 | V | $R_L = 54\Omega$ or 100Ω , Figure 4. |

UNLESS OTHERWISE NOTED: $V_{CC} = +3.3V \pm 5\%$ OR $+5.0V \pm 5\%$; $T_A = T_{MIN}$ TO T_{MAX} . TYPICAL VALUES ARE AT $V_{CC} = 3.3V$, $T_A = +25^\circ C$.

| SYMBOL | PARAMETERS | MIN. | TYP. | MAX. | UNITS | CONDITIONS |
|---|---|------|------|-----------|------------|--|
| V_{OC} | Driver Common Mode Output Voltage | | | 3 | V | $R_L = 54\Omega$ or 100Ω , Figure 4. |
| ΔV_{OC} | Change In Magnitude of Common Mode Output Voltage | | | 0.2 | V | $R_L = 54\Omega$ or 100Ω , Figure 4. |
| | Driver Output Short Circuit Current | | | ± 250 | mA | $V = +12V$ to $-7V$, Figure 6. |
| I_O | Output Leakage Current | | | ± 100 | μA | $DE = 0V$ or Shutdown, $V_O = +12V$ to $-7V$. $V_{CC} = 0V$ or $5.25V$. |
| TIMING CHARACTERISTICS | | | | | | |
| RS-232 (SLEW = GND, 250kbps, ONE TRANSMITTER SWITCHING) | | | | | | |
| | Maximum Data Rate | 250 | | | kbps | $R_L = 3k\Omega$, $C_L = 1000pF$. |
| t_{PHL}, t_{PLH} | Receiver Propagation Delay | | 100 | | ns | $C_L = 150pF$. |
| $ t_{PHL} - t_{PLH} $ | Receiver Skew | | 50 | | ns | $C_L = 150pF$. |
| $ t_{PHL} - t_{PLH} $ | Driver Skew | | 100 | | ns | |
| t_{THL}, t_{TLH} | Transition-Region Slew Rate from $+3.0V$ to $-3.0V$ or $-3.0V$ to $+3.0V$ | 6 | | 30 | V/ μs | $V_{CC} = 3.3V$, $T_A = 25^\circ C$, $R_L = 3k\Omega$ to $7k\Omega$, $C_L = 150pF$ to $1000pF$, Figures 20 and 21. |
| RS-232 (SLEW = Vcc, 1Mbps, ONE TRANSMITTER SWITCHING) | | | | | | |
| | Maximum Data Rate | 1 | | | Mbps | $R_L = 3k\Omega$, $C_L = 250pF$. |
| t_{PHL}, t_{PLH} | Receiver Propagation Delay | | 100 | | ns | $C_L = 150pF$, Figures 22 and 23. |
| $ t_{PHL} - t_{PLH} $ | Receiver Skew | | 50 | | ns | $C_L = 150pF$. |
| $ t_{PHL} - t_{PLH} $ | Driver Skew | | 25 | | ns | |
| t_{THL}, t_{TLH} | Transition-Region Slew Rate from $+3.0V$ to $-3.0V$ or $-3.0V$ to $+3.0V$ | | 90 | | V/ μs | $V_{CC} = 3.3V$, $R_L = 3k\Omega$ to $7k\Omega$, $C_L = 150pF$ to $1000pF$. |
| RS-485/RS-422 (SLEW = GND, 250kbps, ONE TRANSMITTER SWITCHING) | | | | | | |
| | Maximum Data Rate | | | 250 | kbps | $R_{DIFF} = 54\Omega$, $C_L = 50pF$. |
| t_{DPHL}, t_{DPLH} | Differential Output Propagation Delay Time | 250 | | 1500 | ns | Figures 7 and 8. |
| t_R, t_F | Driver Rise and Fall Time | 200 | | 1500 | ns | Figures 7 and 8. |
| $ t_{DPHL} - t_{DPLH} $ | Driver Propagation Delay Skew | | | 200 | ns | Figures 7 and 8. |
| t_{DZH}, t_{DZL} | Driver Output Enable Time | | | 1500 | ns | Figures 9, 10, 11 and 12. |
| t_{DHZ}, t_{DLZ} | Driver Output Disable Time | | | 1500 | ns | Figures 9, 10, 11 and 12. |
| t_{PHL}, t_{PLH} | Receiver Propagation Delay | | | 150 | ns | Figures 13 and 14. |
| t_{ZH} | Receiver Enable to Output High | | 50 | | ns | Figures 15 and 16. |
| t_{ZL} | Receiver Enable to Output Low | | 50 | | ns | Figures 15 and 17. |

UNLESS OTHERWISE NOTED: $V_{CC} = +3.3V \pm 5\%$ OR $+5.0V \pm 5\%$; $T_A = T_{MIN}$ TO T_{MAX} . TYPICAL VALUES ARE AT $V_{CC} = 3.3V$, $T_A = +25^{\circ}C$.

| SYMBOL | PARAMETERS | MIN. | TYP. | MAX. | UNITS | CONDITIONS |
|--|--|------|------|------|-------|--|
| t_{HZ} | Receiver Output High to Disable | | 50 | | ns | Figures 15 and 18. |
| t_{LZ} | Receiver Output Low to Disable | | 50 | | ns | Figures 15 and 19. |
| RS-485/RS-422 (SLEW = V_{CC}, 10Mbps, ONE TRANSMITTER SWITCHING) | | | | | | |
| | Maximum Data Rate | | | 10 | Mbps | $R_{DIFF} = 54\Omega$, $C_L = 50pF$. |
| t_{DPHL}, t_{DPLH} | Differential Output Propagation Delay Time | | 60 | 120 | ns | Figures 7 and 8. |
| t_R, t_F | Driver Rise and Fall Time | | 10 | 25 | ns | Figures 7 and 8. |
| $ t_{DPHL} - t_{DPLH} $ | Driver Propagation Delay Skew | | | 10 | ns | Figures 7 and 8. |
| t_{DZH}, t_{DZL} | Driver Output Enable Time | | | 900 | ns | Figures 9, 10, 11 and 12. |
| t_{DHZ}, t_{DLZ} | Driver Output Disable Time | | | 900 | ns | Figures 9, 10, 11 and 12. |
| t_{PHL}, t_{PLH} | Receiver Propagation Delay | | | 150 | ns | Figures 13 and 14. |
| t_{ZH} | Receiver Enable to Output High | | 32 | | ns | Figures 15 and 16. |
| t_{ZL} | Receiver Enable to Output Low | | 32 | | ns | Figures 15 and 17. |
| t_{HZ} | Receiver Output High to Disable | | 40 | | ns | Figures 15 and 18. |
| t_{LZ} | Receiver Output Low to Disable | | 40 | | ns | Figures 15 and 19. |

1.0 FUNCTION TABLES

The SP336E drivers and receivers may be configured to operate as either standard RS-485/RS-422 or RS-232 devices. RS-485/RS422 drivers have differential outputs and receivers have differential inputs. RS-232 drivers and receivers are single-ended with inverting outputs.

TABLE 1: R-485/RS-422 FULL DUPLEX: MODE 011 (T3, R3), MODE 101 (T1, T3, R1, R3)

| DRIVERS | | | | RECEIVERS | |
|---------|-------|---------|-------|----------------|--------|
| Inputs | | Outputs | | Inputs | Output |
| Tx_EN | Tx_In | Tx(A) | Tx(B) | Rx(A) - Rx(B) | RxOut |
| 1 | 1 | 1 | 0 | > -50mV | 1 |
| 1 | 0 | 0 | 1 | ≤ -200mV | 0 |
| 0 | x | High-Z | | Open / Shorted | 1 |

TABLE 2: R-485/RS-422 HALF DUPLEX: MODE 010 (T3, R3), MODE 100 (T1, T3, R1, R3)

| TRANSMITTING | | | | RECEIVING | | |
|--------------|------|---------|--------|-----------|----------------|---------|
| Inputs | | Outputs | | Inputs | | Outputs |
| DE/RE | TxIn | Tx(A) | Tx(B) | DE/RE | Rx(A) - Rx(B) | RxOut |
| 1 | 1 | 1 | 0 | 1 | x | High-Z |
| 1 | 0 | 0 | 1 | 1 | x | High-Z |
| 0 | x | High-Z | High-Z | 0 | > -50mV | 1 |
| | | | | 0 | ≤ -200mV | 0 |
| | | | | 0 | Open / Shorted | 1 |

TABLE 3: RS-232 MODE 001 (ALL TX AND RX), MODES 011, 010 (T1, T2, R1, R2), MODE 110 (R1- R4)

| DRIVERS | | RECEIVERS | |
|---------|--------|-----------|--------|
| Input | Output | Input | Output |
| 0 | ≥ 5V | ≥ 3V | 0 |
| 1 | ≤ -5V | ≤ -3V | 1 |
| Open | ≤ -5V | Open | 1 |

FIGURE 4. RS-485 DRIVER DC TEST CIRCUIT

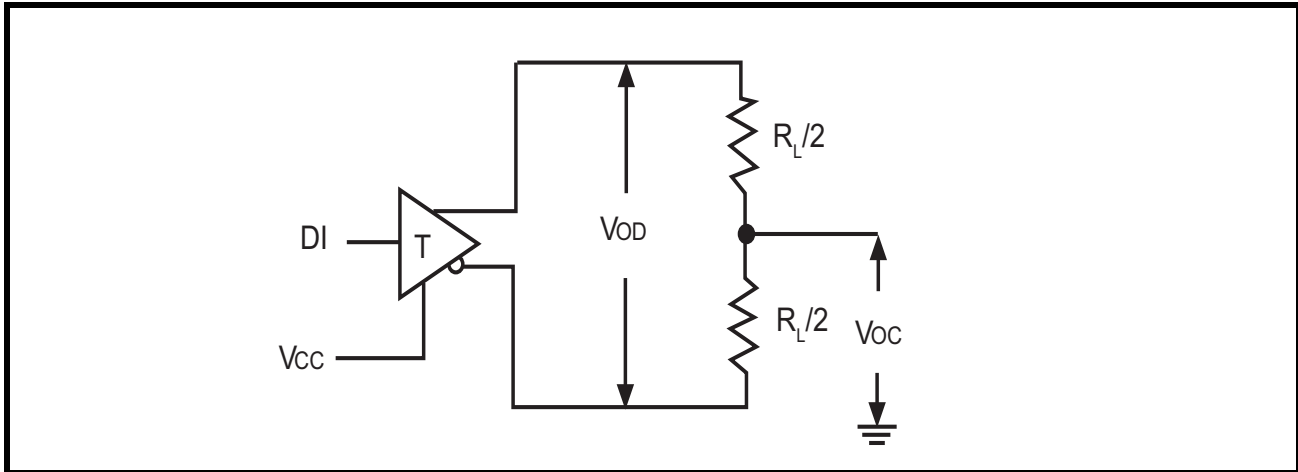

FIGURE 5. RS-485 DRIVER COMMON MODE LOAD TEST

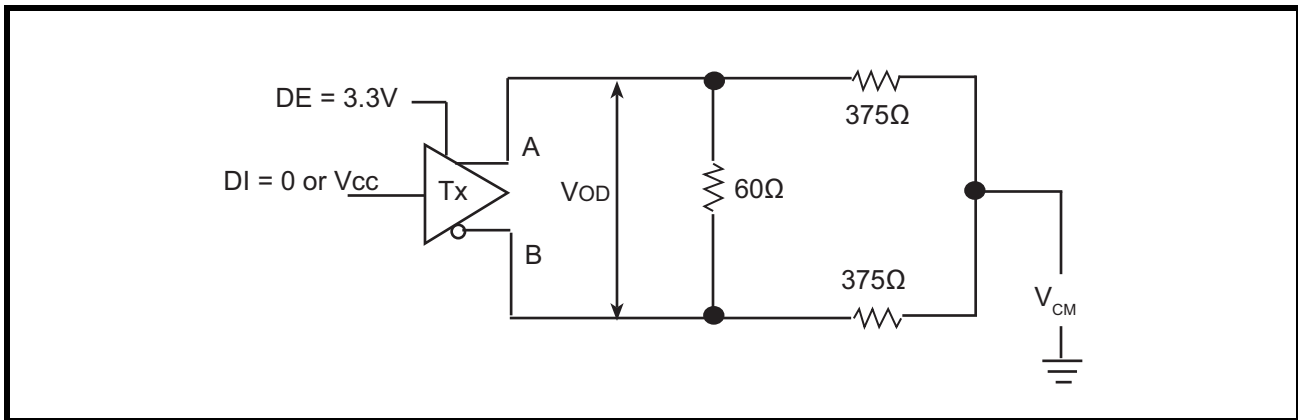

FIGURE 6. RS-485 DRIVER OUTPUT SHORT CIRCUIT TEST

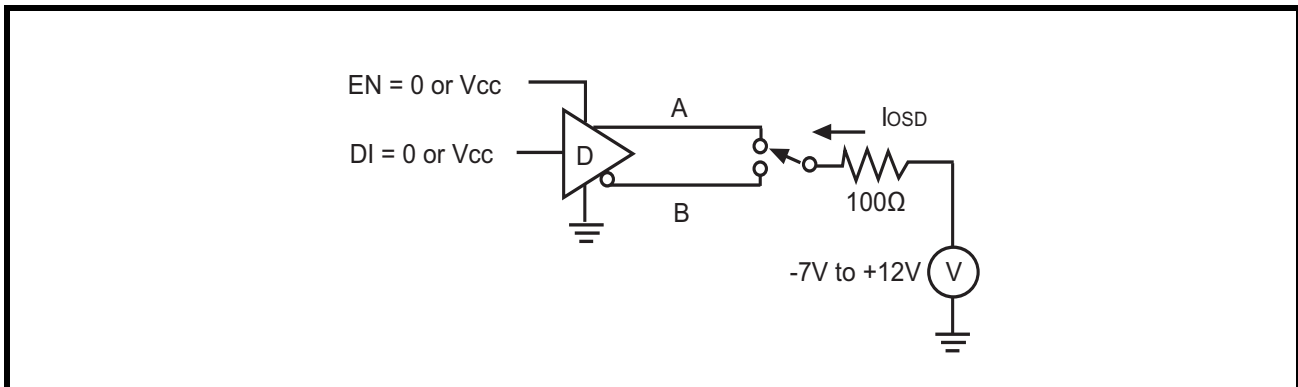

FIGURE 7. RS-485 DRIVER PROPAGATION DELAY TEST CIRCUIT

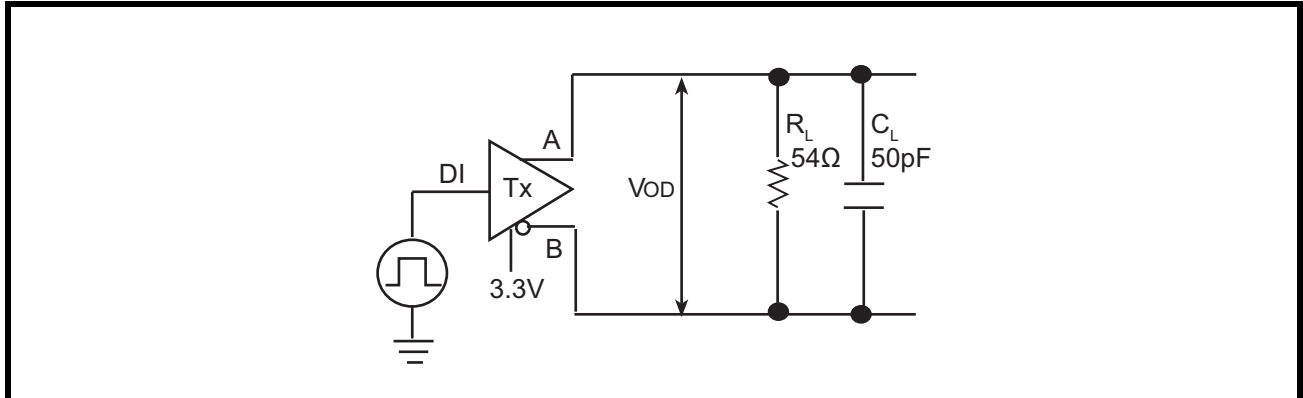

FIGURE 8. RS-485 DRIVER TIMING DIAGRAM

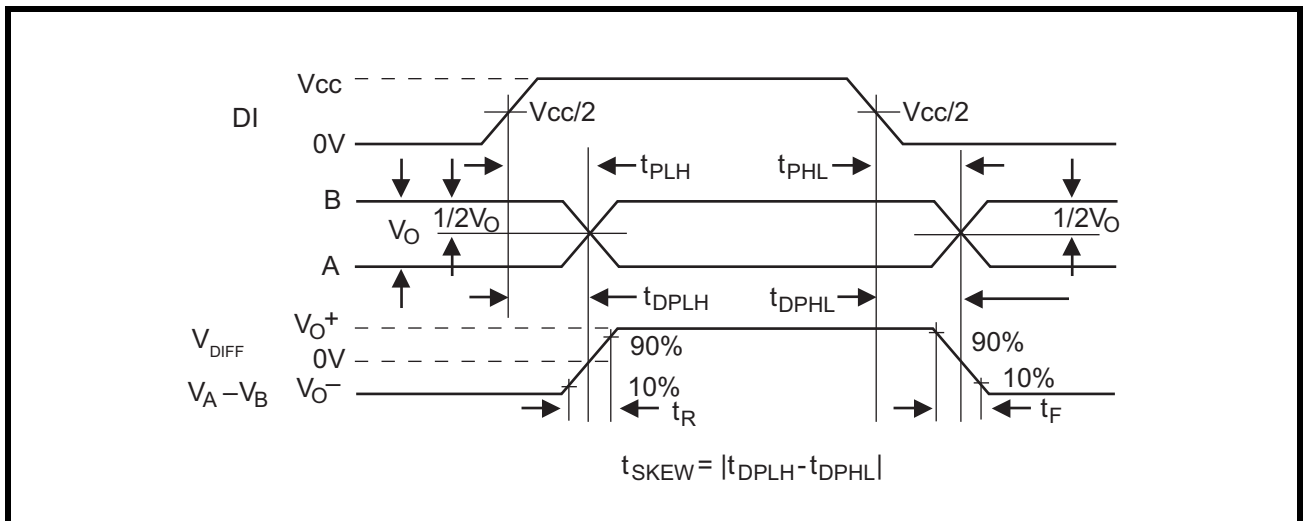

FIGURE 9. RS-485 DRIVER ENABLE AND DISABLE TEST CIRCUIT

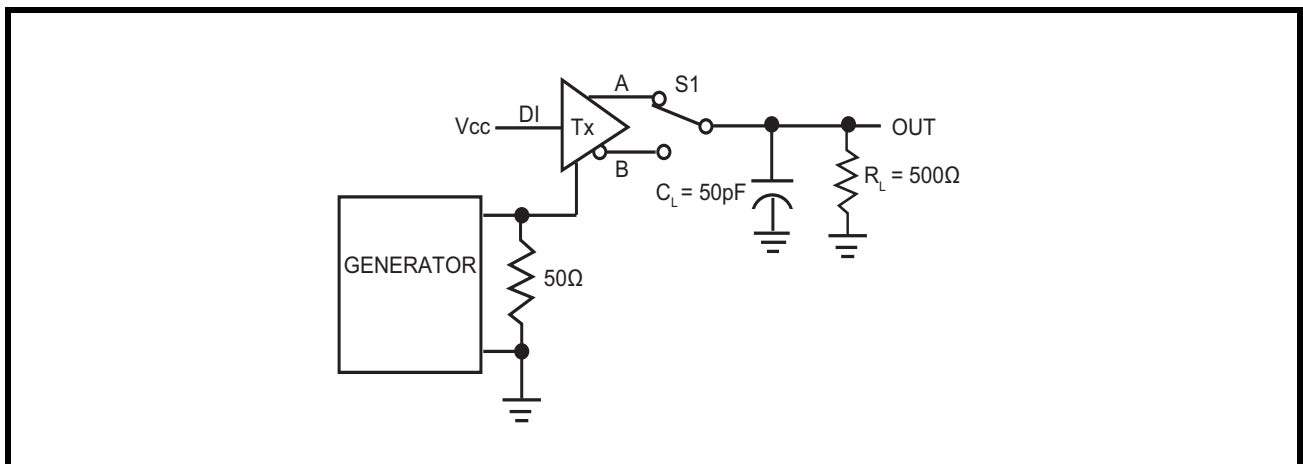

FIGURE 10. RS-485 DRIVER ENABLE AND DISABLE TIMING DIAGRAM

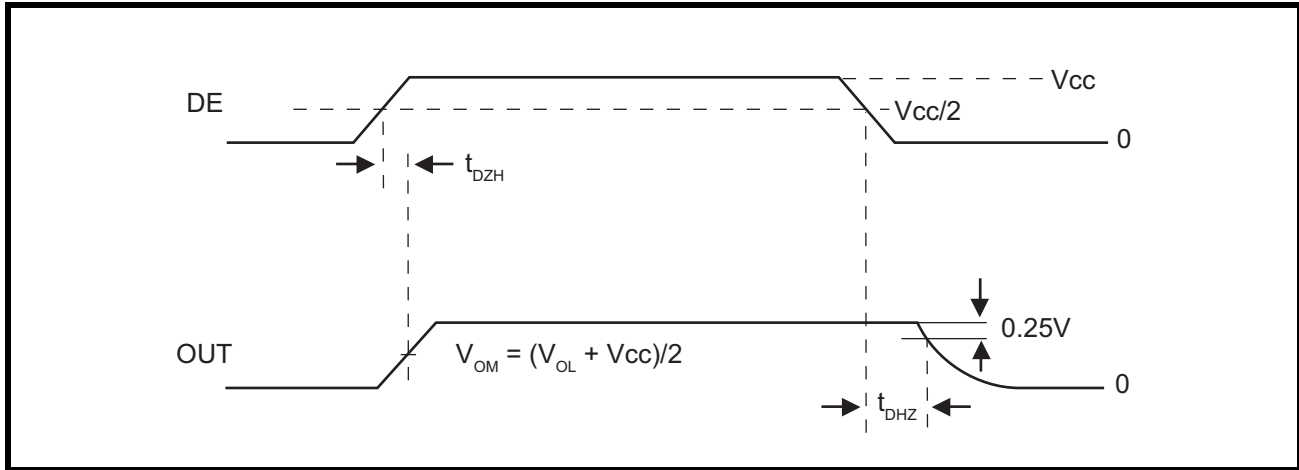

FIGURE 11. RS-485 DRIVER ENABLE AND DISABLE TEST CIRCUIT 2

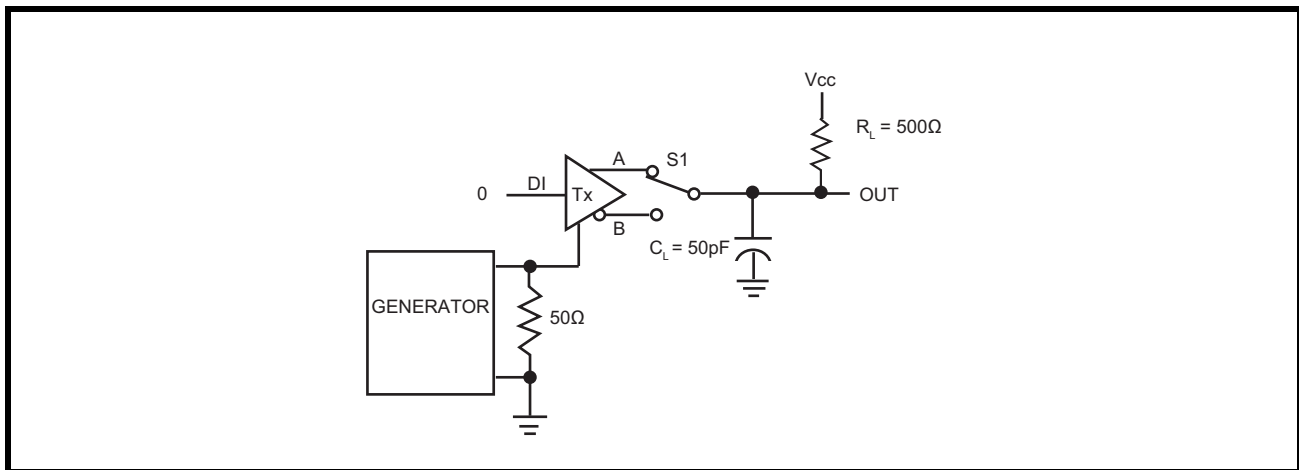

FIGURE 12. RS-485 DRIVER ENABLE AND DISABLE TIMING DIAGRAM 2

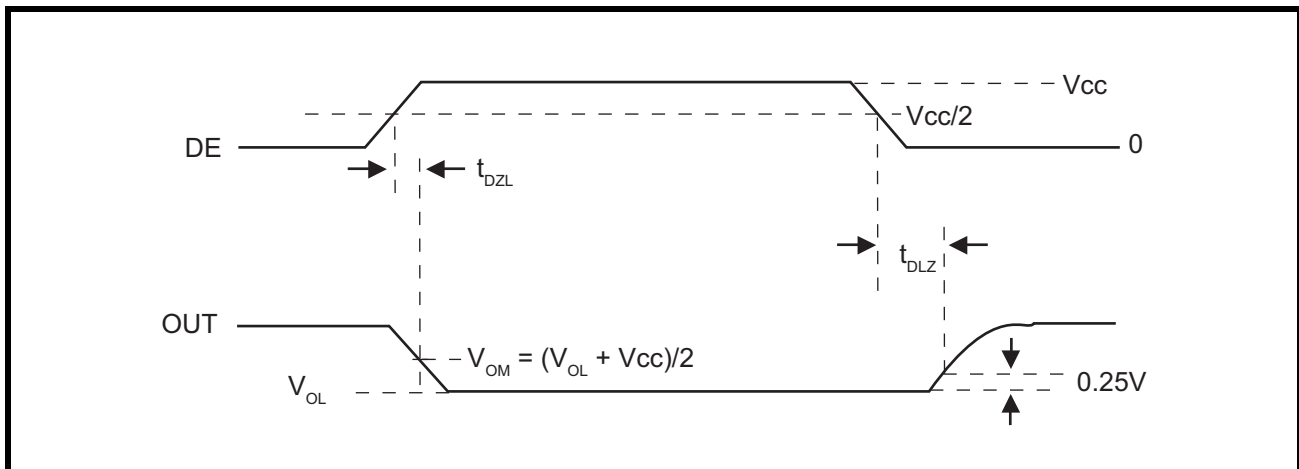

FIGURE 13. RS-485 RECEIVER PROPAGATION DELAY TEST CIRCUIT

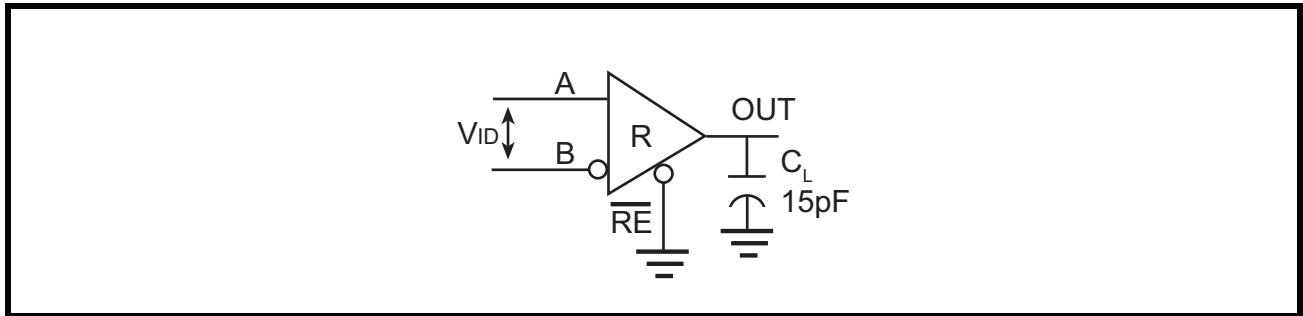

FIGURE 14. RS-485 RECEIVER PROPAGATION DELAY TIMING DIAGRAM

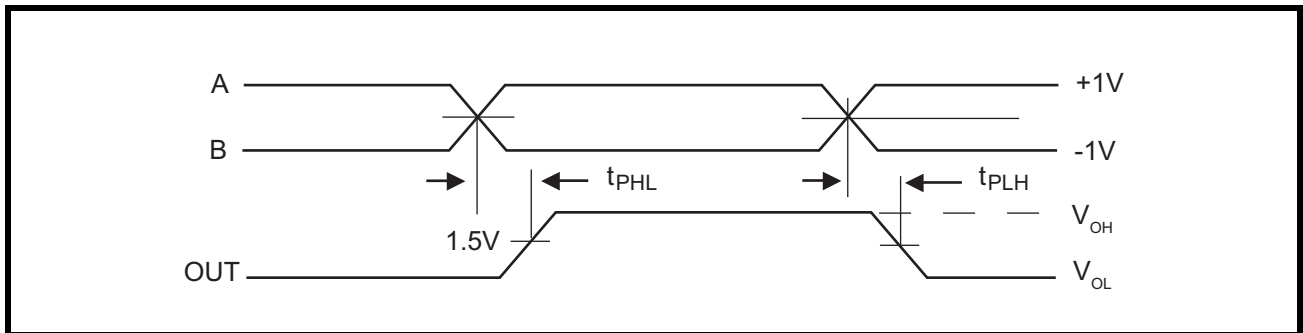

FIGURE 15. RS-485 RECEIVER ENABLE AND DISABLE TIMES TEST CIRCUIT

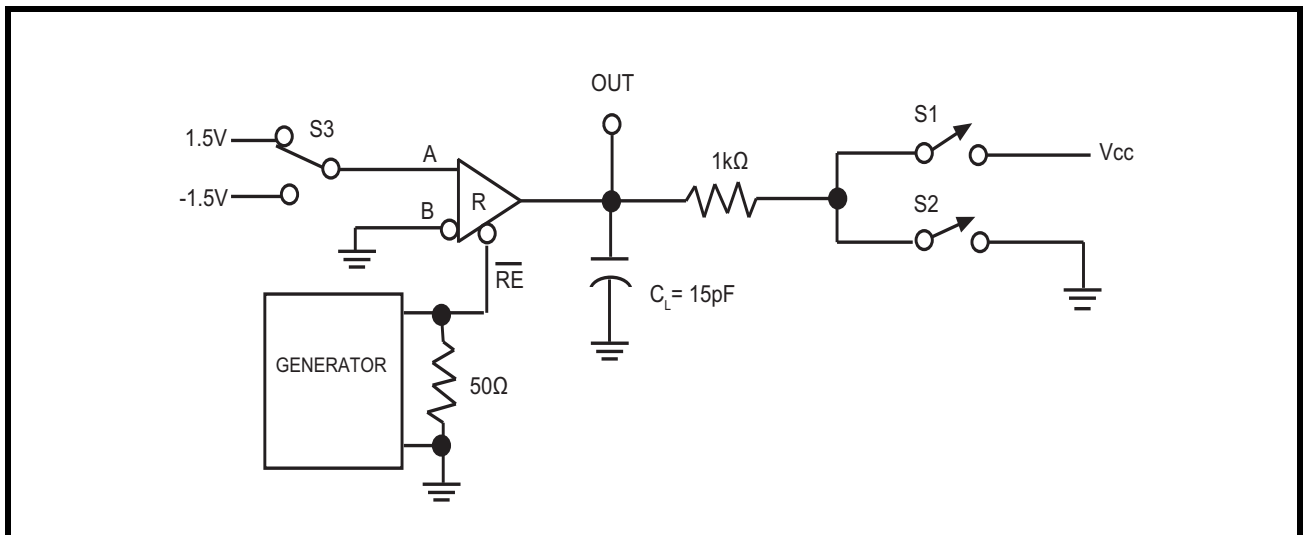

FIGURE 16. RS-485 RECEIVER ENABLE AND DISABLE TIMES TIMING DIAGRAM 1

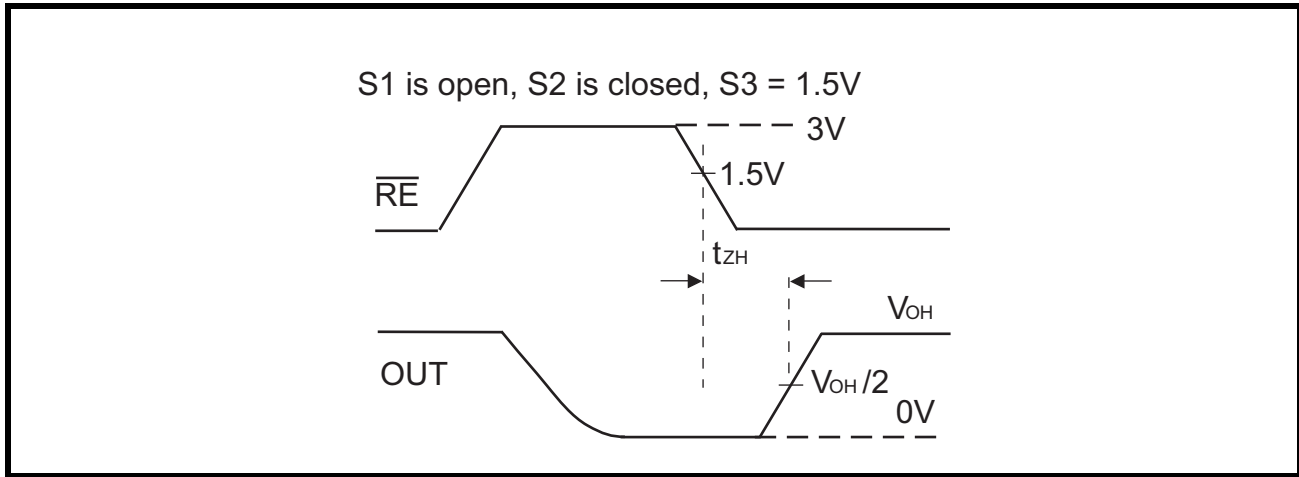

FIGURE 17. RS-485 RECEIVER ENABLE AND DISABLE TIMES TIMING DIAGRAM 2

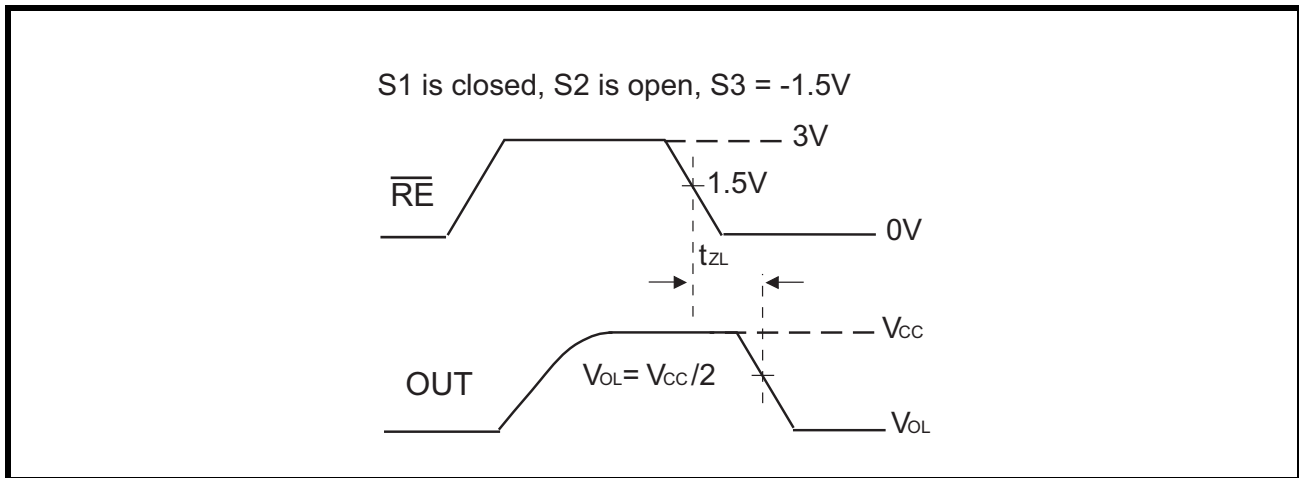

FIGURE 18. RS-485 RECEIVER ENABLE AND DISABLE TIMES TIMING DIAGRAM 3

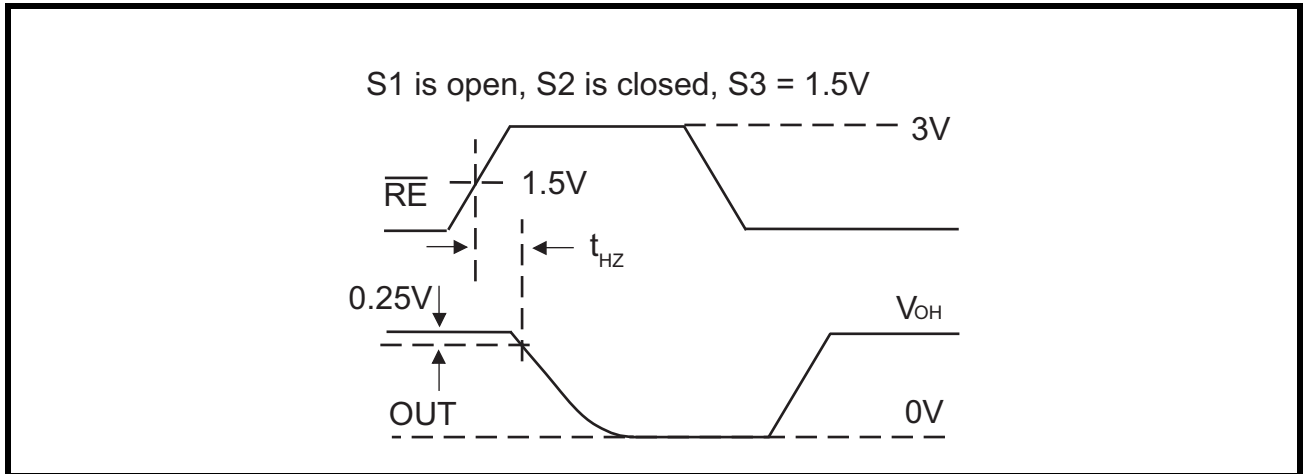

FIGURE 19. RS-485 RECEIVER ENABLE AND DISABLE TIMES TIMING DIAGRAM 4

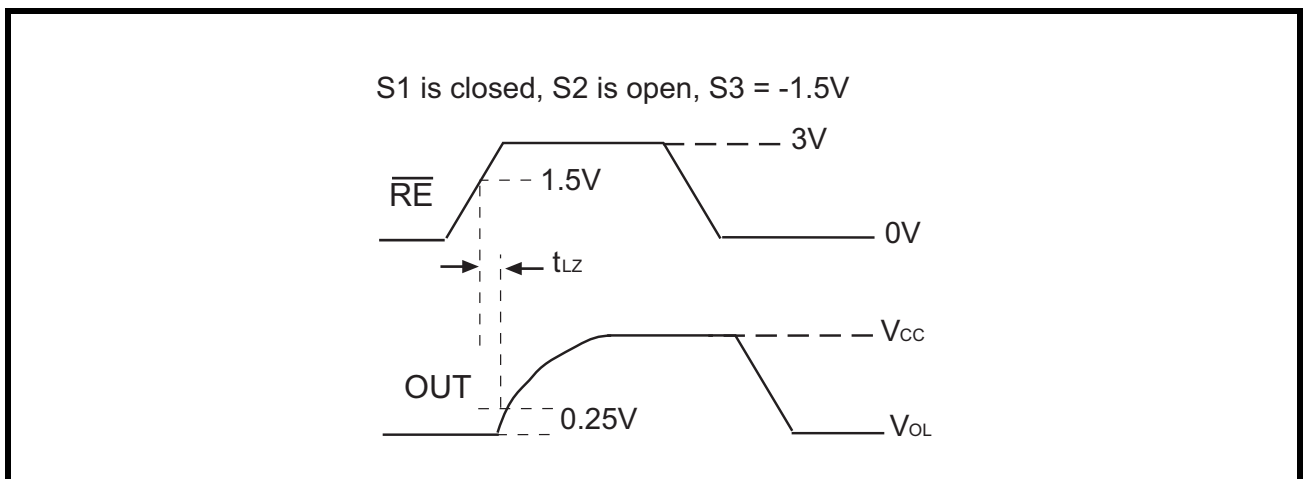

FIGURE 20. RS-232 DRIVER OUTPUT SLEW RATE TEST CIRCUIT

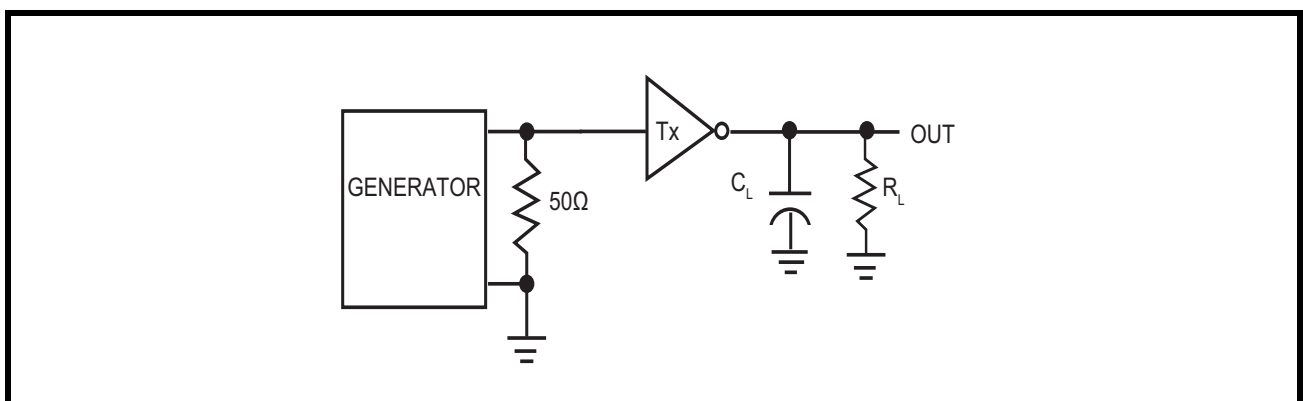

FIGURE 21. RS-232 DRIVER OUTPUT SLEW RATE TIMING DIAGRAM

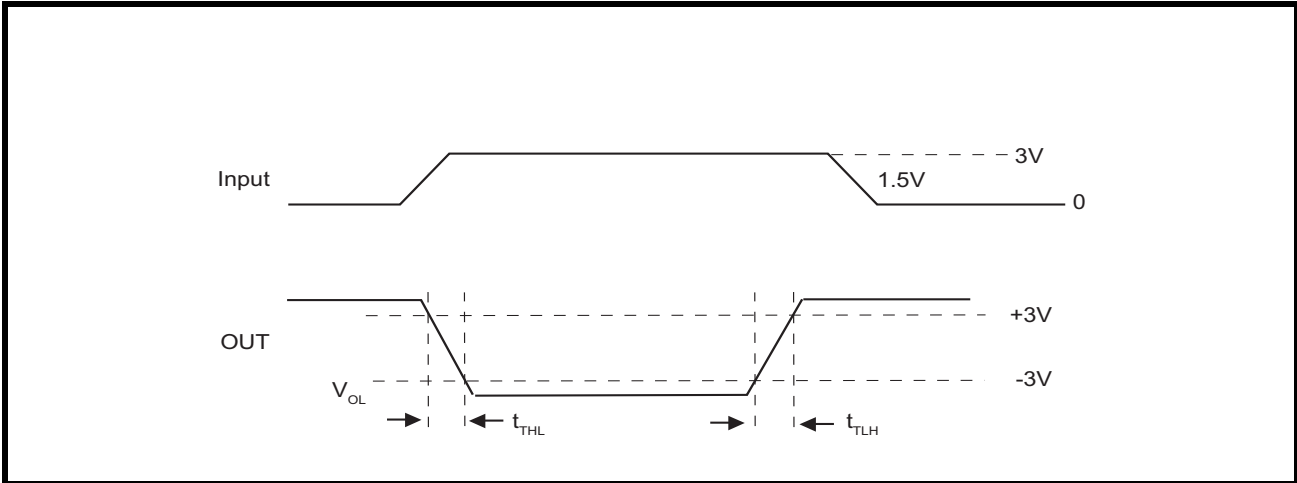

FIGURE 22. RS-232 RECEIVER PROPAGATION DELAY TEST CIRCUIT

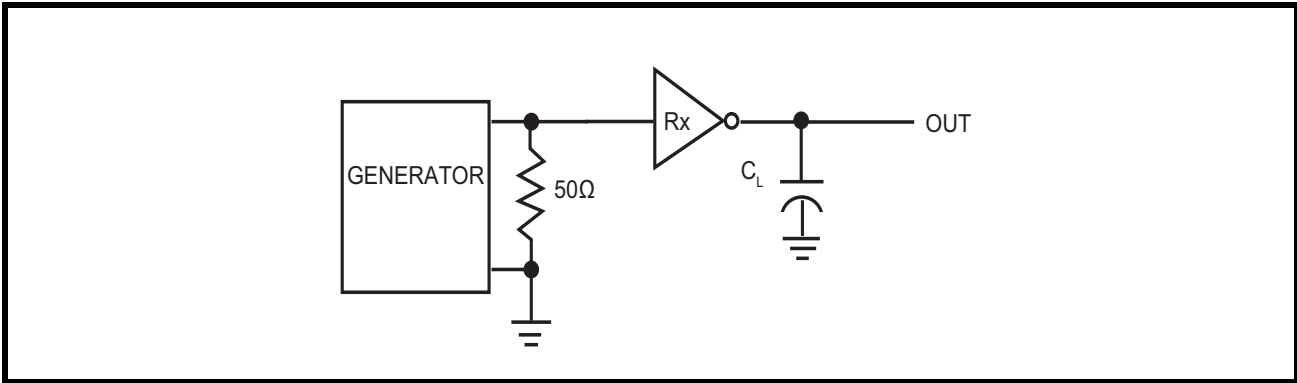
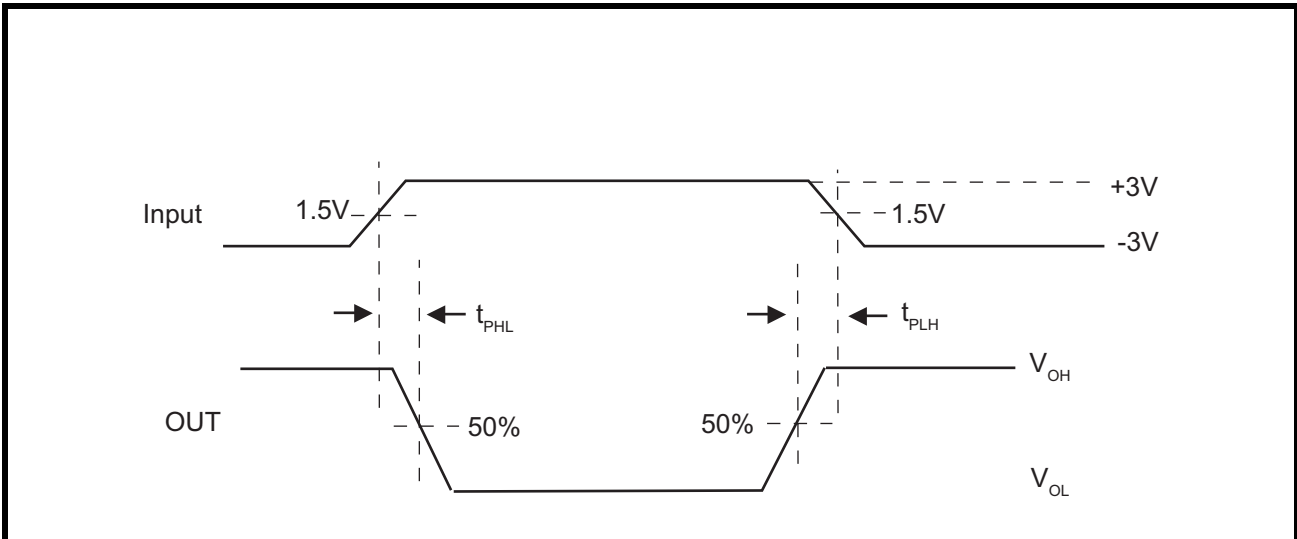

FIGURE 23. RS-232 RECEIVER PROPAGATION DELAY TIMING DIAGRAM



2.0 SUGGESTED APPLICATION DIAGRAMS

The SP336E supports all signals used in RS-232 over an 8 pin modular jack (RJ-45) as defined in TIA/EIA-561. For DTE serial port only three drivers are required. Driver_1 is not used in this configuration and its driver input should be tied to high or low.

SP336E may also be used to implement a standard serial port over a DB-9 connector (TIA/EIA-574 or the standard IBM serial port). In that case either DSR or RI signal can be supported. Both DSR and RI are used mainly for dial-up connections and are typically not needed on dedicated lines. If both signals are required, add a discrete transceiver such as SP3220E.

An alternative implementation would be to use the SP336E to emulate the functionality of two dual-channel RS-232 transceivers (2 x SP232's or equivalent).

Loop-Back

Changing from RS-232 mode (MODE 001) to loop-back mode (MODE 000) duplicates the function of an external loop-back plug. Loop-back can be used to test serial port functionality or to diagnose faults.

FIGURE 24. RS-232E SERIAL PORT (EIA-561 / EIA-574)

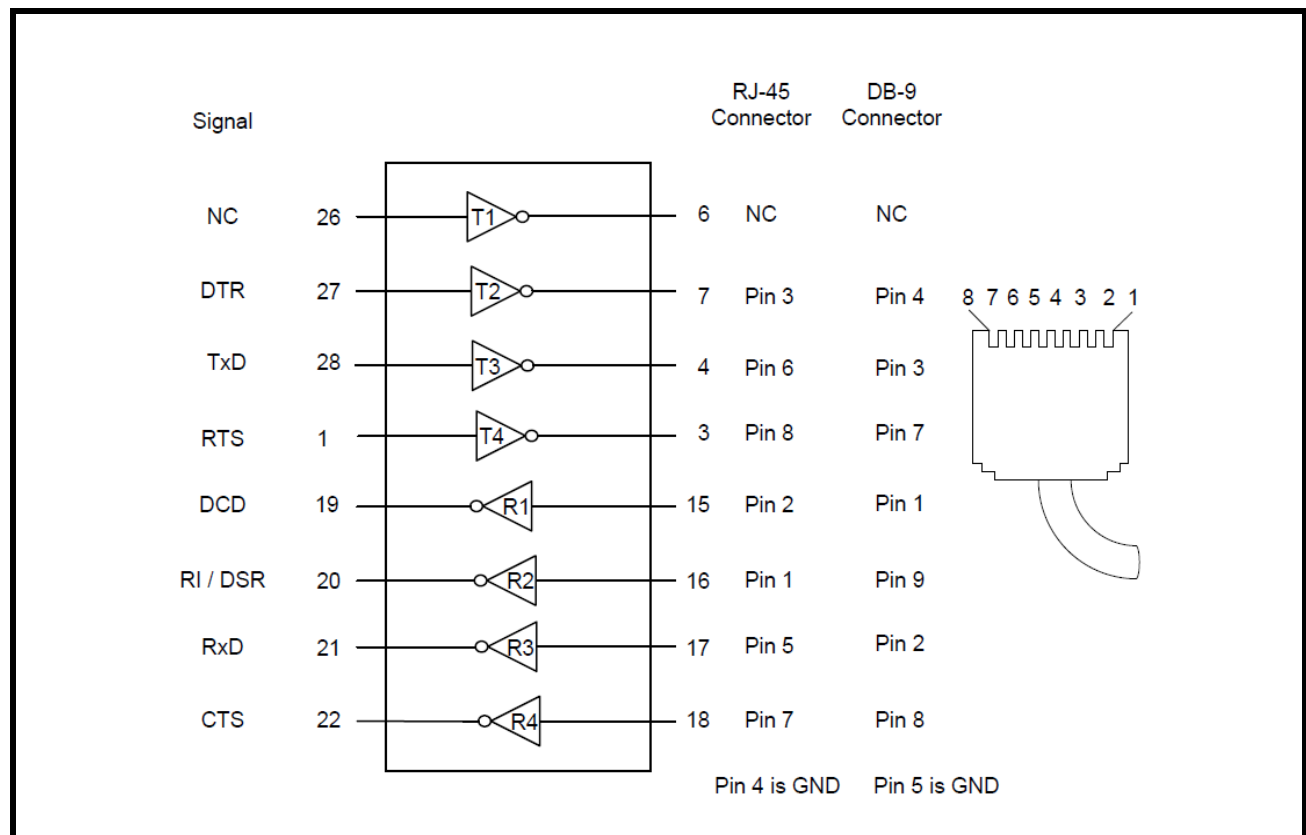

RS-232 to RS-485 Translator

SP336E can be used to implement a single-chip RS-232 to RS-485 translator function. Both full-duplex (4-wire RS-485) and half-duplex (2-wire RS-485) configurations are shown. RS-485 is capable of communicating on data cables up to 4000 feet (1200 meter) which makes it an ideal interface for extending the reach of short-range serial ports like RS-232. The configurations shown can be used to connect directly to existing PC type RS-232 serial ports to enable extended-reach communication.

The RTS signal (circuit CA or 105) is used as a transmit direction control signal for half-duplex. The ON condition puts the repeater into transmit mode and inhibits receive. On a half-duplex channel RxD should be held in MARK state (binary 1) when receiver 3 is inactive. Driver 1 on the SP336E can be used to generate DSR or CTS signal to indicate to the host terminal that the translator is powered-on and ready.

Shutdown Modes

SP336E features two shutdown modes. In mode 111 (full shutdown) all drivers and receivers are at high impedance. In mode 110, all drivers are tri-state but all four receivers remain active. In modes 101 and 100 two differential receivers can be kept active while the differential drivers are tri-stated using the Tx_EN inputs.

FIGURE 25. RS-232 / RS-485 TRANSLATOR FULL-DUPLEX CABLE-EXTENDER (MODE 011)

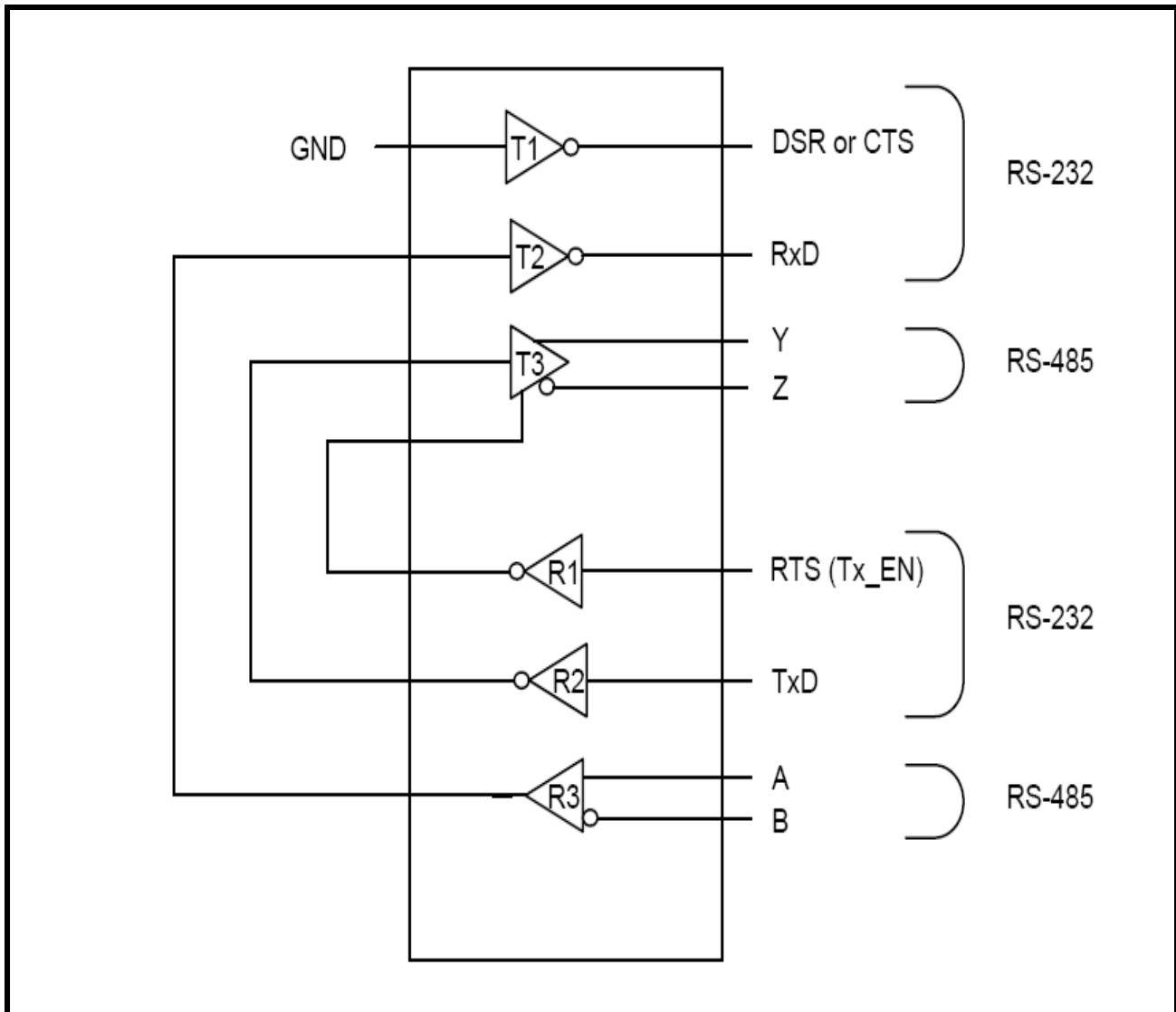
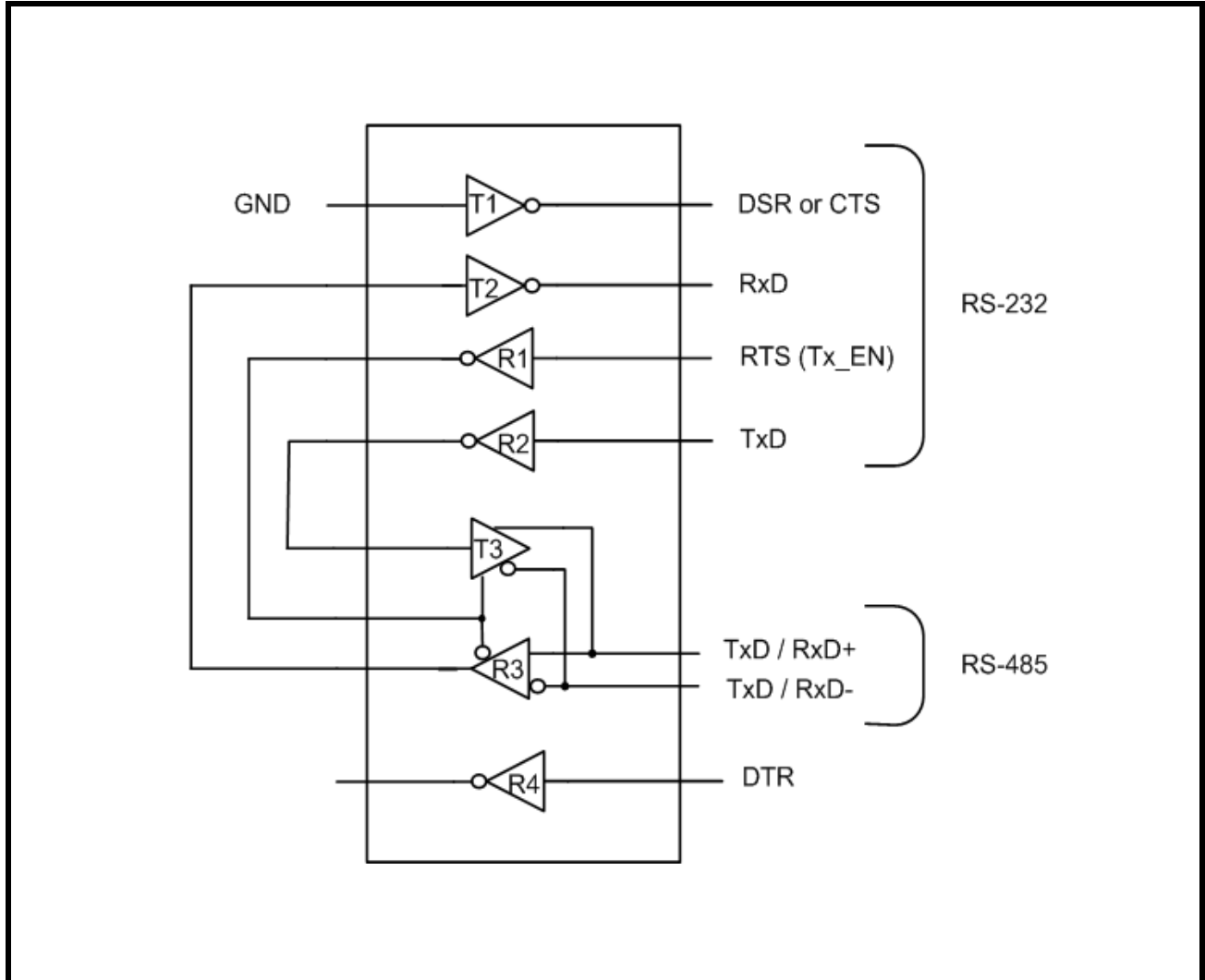

FIGURE 26. RS-232 / RS-485 TRANSLATOR HALF-DUPLEX CABLE-EXTENDER (MODE 010)



Bus Repeater

Mode 101 can be used as a bus-repeater to extend the reach of an RS-422 bus. This configuration is best suited for point-to-point or multi-drop communications because the drivers are always active and echoing data from their corresponding receiver.

For applications where multiple nodes are allowed to transmit, some type of bus arbitration should be used. One technique would be to use SP336E in conjunction with external decoder logic, packet buffers and node address fields embedded in the data stream. Receiving the correct node address triggers Tx_EN to pass data onward.

Mode 100 could implement a repeater / gateway to partition or extend RS-485 networks. Direction Control determines when data is forwarded to or from segments A and B.

FIGURE 27. RS-422 BUS-REPEATER (MODE 101)

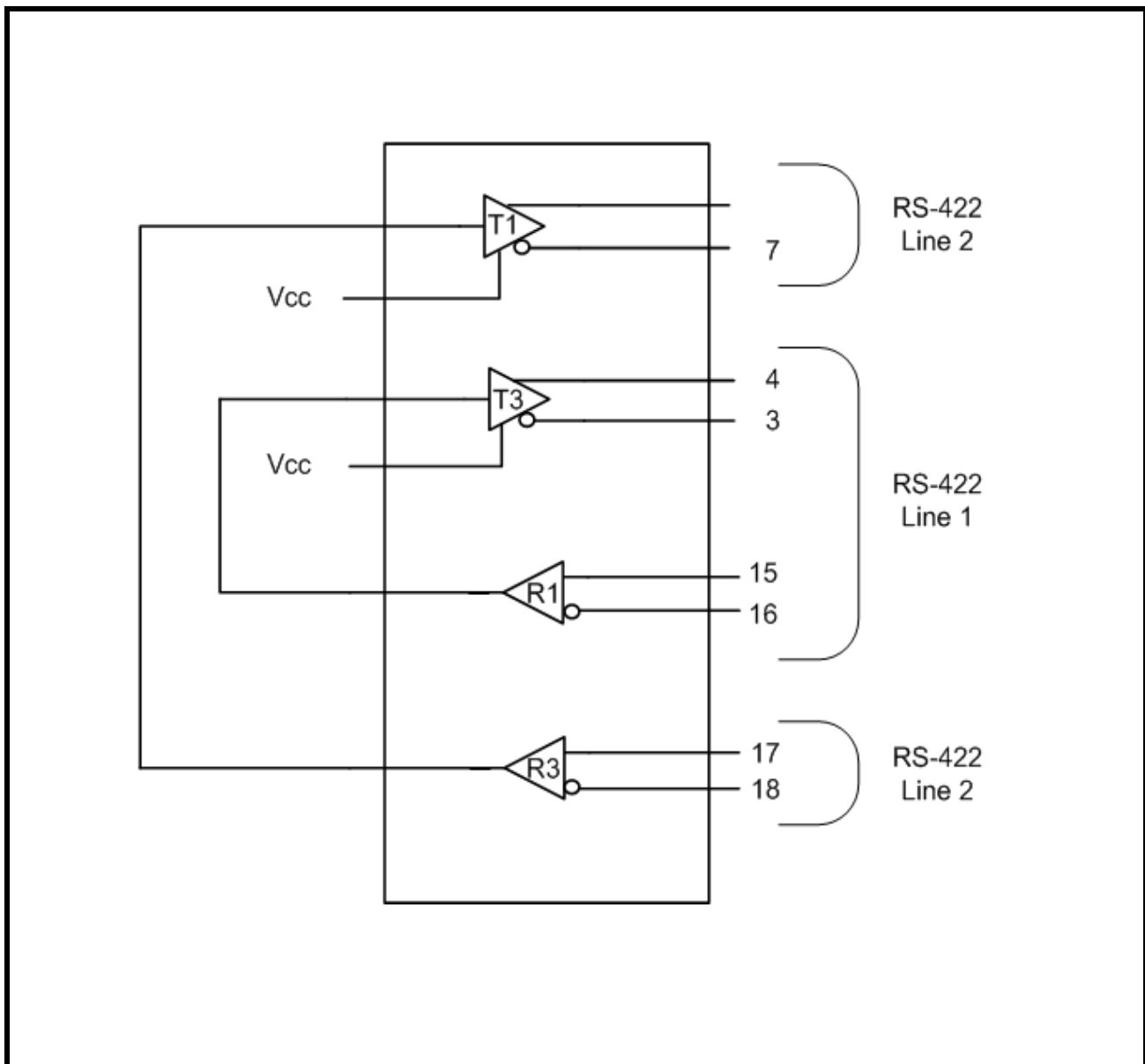

FIGURE 28. RS-485 BUS-REPEATER (MODE 100)

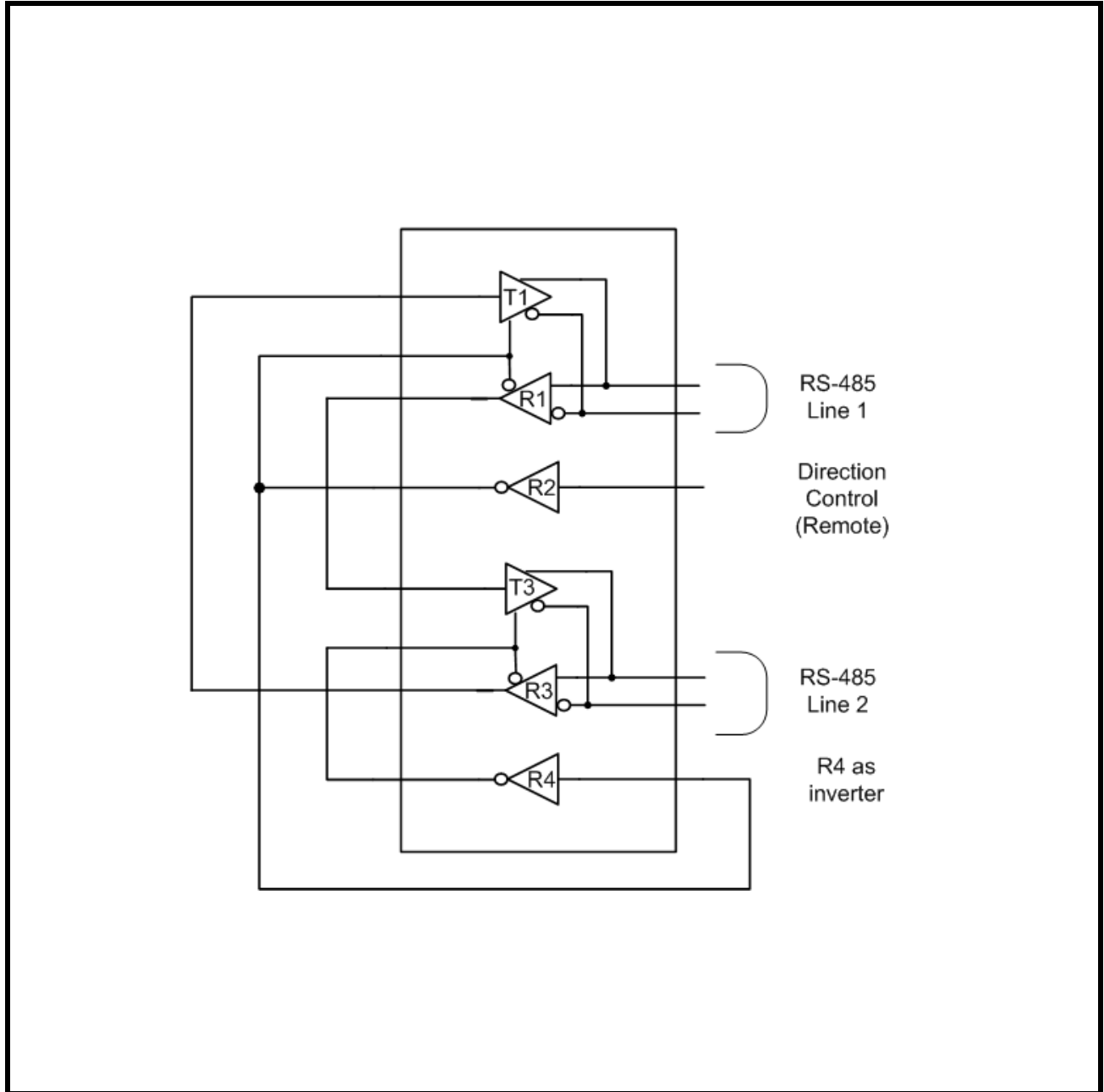

FIGURE 29. 28 PIN SOICW PACKAGE OUTLINE DRAWING

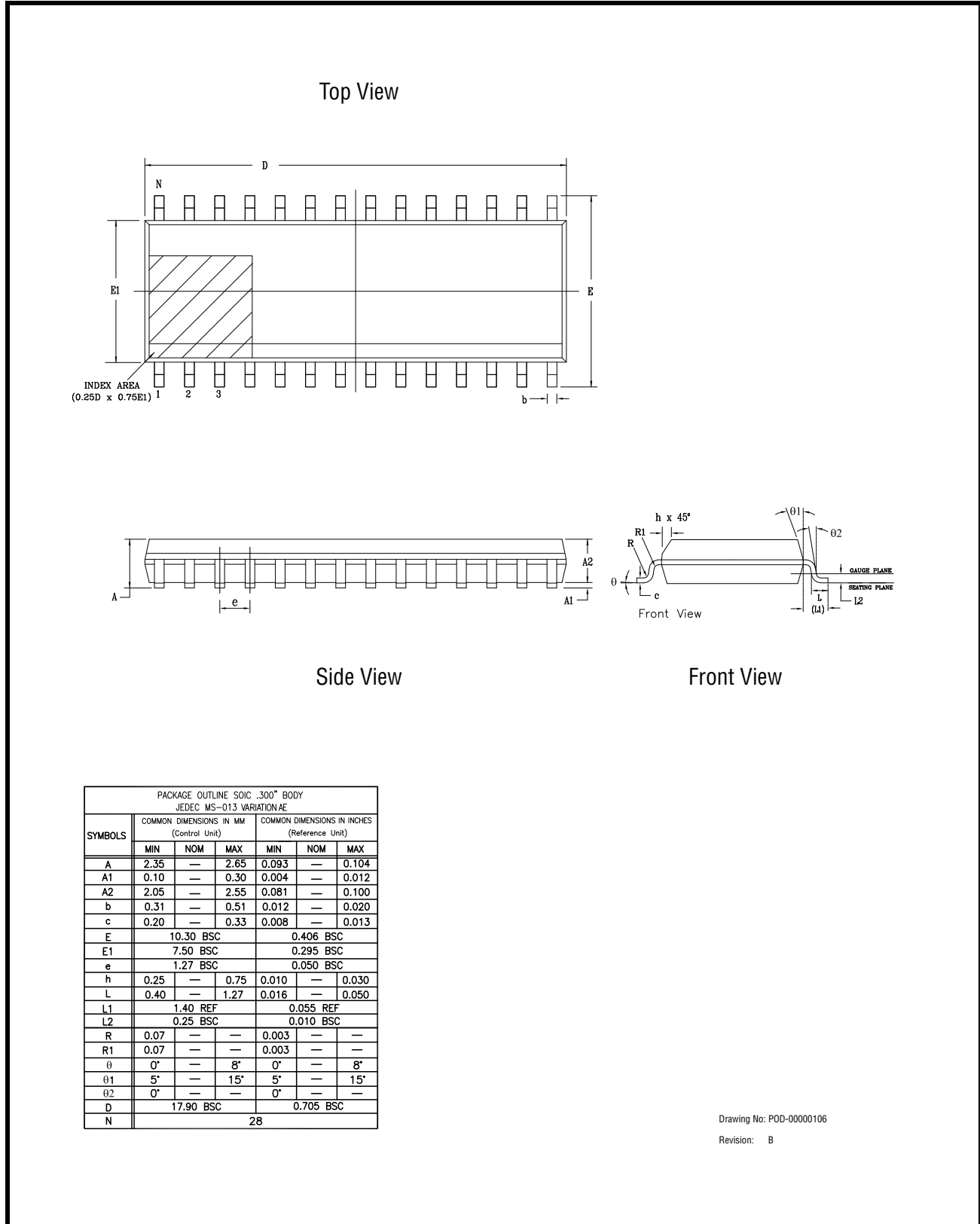
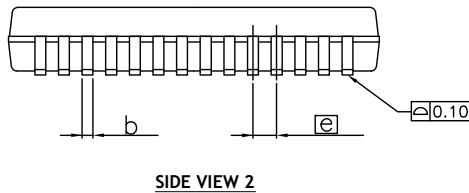
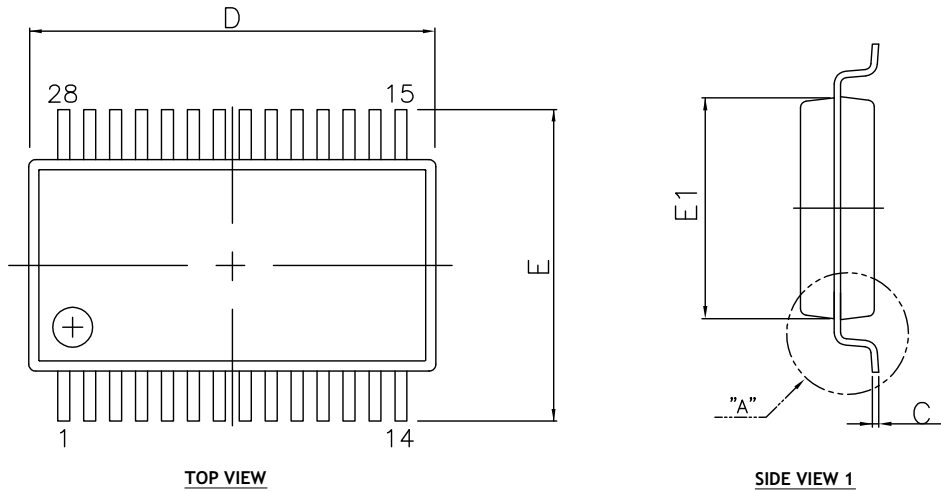
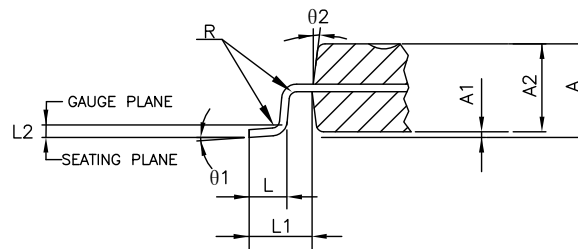

FIGURE 30. 28 PIN TSSOP MECHANICAL DIMENSIONS



| DIM SYMBOL | MIN | NOM | MAX |
|------------|------|----------|------|
| A | - | - | 1.20 |
| A1 | 0.05 | - | 0.15 |
| A2 | 0.80 | 1.00 | 1.05 |
| b | 0.19 | - | 0.30 |
| L1 | | 1.00 REF | |
| L2 | | 0.25 BSC | |
| e | | 0.65 BSC | |
| c | 0.09 | - | 0.20 |
| E | | 6.40 BSC | |
| E1 | 4.30 | 4.40 | 4.50 |
| L | 0.45 | 0.60 | 0.75 |
| R | 0.09 | - | - |
| D | 9.60 | 9.70 | 9.80 |
| θ1 | 0 | 4 | 8 |
| θ2 | | 12 REF | |
| N | | 28 | |

TERMINAL DETAILS



DETAIL A

- ALL DIMENSIONS ARE IN MILLIMETERS, ANGLES ARE IN DEGREES.
- DIMENSIONS AND TOLERANCE PER JEDEC MO-153.

Drawing No.: POD-000000 134

Revision: A

FIGURE 31. 28 PIN TSSOP RECOMMENDED LAND PATTERN AND STENCIL

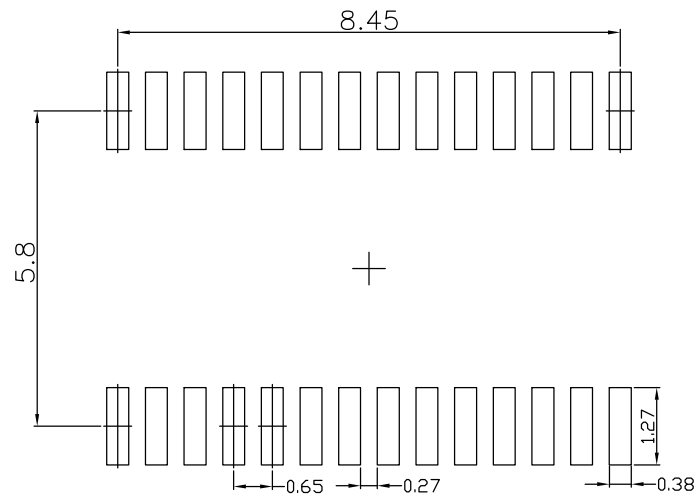

TYPICAL RECOMMENDED LAND PATTERN

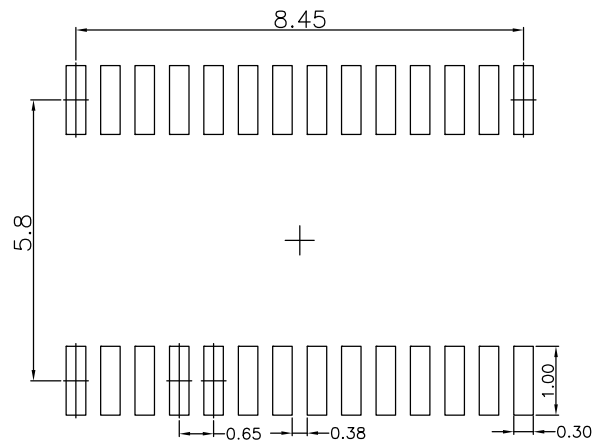

TYPICAL RECOMMENDED STENCIL

Drawing No.: POD-000000 134

Revision: A