

3.3V Low Power Slew Rate Limited Half-Duplex RS-485 Transceiver

Description

The [SP3483](#) device is part of a family of 3.3V low power half-duplex transceivers that meet the specifications of the RS-485 and RS-422 serial protocols. This device is pin-to-pin compatible with the MaxLinear SP483 device as well as popular industry standards. The SP3483 features MaxLinear's BiCMOS design allowing low power operation without sacrificing performance. The SP3483 is slew rate limited to reduce EMI and can meet the requirements of the RS-485 and RS-422 protocols up to 250kbps.

FEATURES

- RS-485 and RS-422 transceiver
- Operates from a single 3.3V Supply
- Interoperable with 5.0V logic
- Driver/receiver enable
- Low power shutdown mode
- -7V to +12V common-mode input voltage range
- Allows up to 32 transceivers on the serial bus
- Compatibility with the industry standard 75176 pinout
- Driver output short-circuit protection
- Slew rate limited driver for low EMI

Ordering Information - [Back Page](#)

Block Diagram

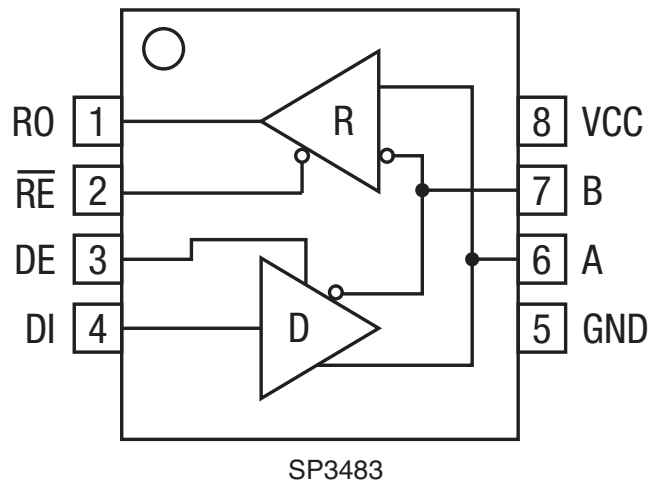

Absolute Maximum Ratings

These are stress ratings only and functional operation of the device at these ratings or any other above those indicated in the operation sections of the specifications below is not implied. Exposure to absolute maximum rating conditions for extended periods of time may affect reliability.

V_{CC} 6.0V

Input Voltages

Logic -0.3V to 6.0V

Drivers -0.3V to 6.0V

Receivers..... ±15V

Output Voltages

Drivers ±15V

Receivers..... -0.3V to 6.0V

Storage Temperature-65°C to +150°C

Maximum Junction Temperature, T_J 125°C

Power Dissipation

8-pin NSOIC 500mW

(derate 6.14mW/°C above +70°C)

Operating Conditions

Package Power Dissipation

8-pin NSOIC Θ_{JA} 128.4°C/W

ESD Rating

Human Body Model (HBM)..... ±2kV

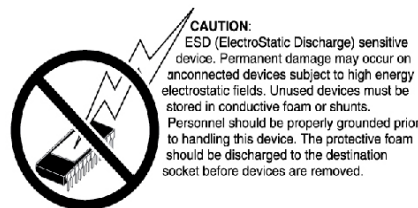

Electrical Characteristics

T_{AMB} = T_{MIN} to T_{MAX} and V_{CC} = 3.3V ±5% unless otherwise noted.

| PARAMETERS | MIN. | TYP. | MAX. | UNITS | CONDITIONS |
|--|------|------|-----------------|-------|---|
| SP3483 Driver DC Characteristics | | | | | |
| Differential output voltage | | | V _{CC} | V | Unloaded; R = ∞Ω ; Figure 1 |
| Differential output voltage | 2 | | V _{CC} | V | With Load; R = 50Ω (RS-422); Figure 1 |
| Differential output voltage | 1.5 | | V _{CC} | V | With Load; R = 27Ω (RS-485); Figure 1 |
| Change in magnitude of driver differential output voltage for complimentary states | | | 0.2 | V | R = 27Ω or R = 50Ω; Figure 1 |
| Driver common-mode output voltage | | | 3 | V | R = 27Ω or R = 50Ω; Figure 1 |
| Input high voltage | 2.0 | | | V | Applies to DE, DI, RE |
| Input low voltage | | | 0.8 | V | Applies to DE, DI, RE |
| Input current | | | ±10 | μA | Applies to DE, DI, RE |
| Driver short circuit current V _{OUT} = HIGH | | | ±250 | mA | -7V ≤ V _O ≤ +12V; Figure 8 |
| Driver short circuit current V _{OUT} = LOW | | | ±250 | mA | -7V ≤ V _O ≤ +12V; Figure 8 |
| SP3483 Driver AC Characteristics | | | | | |
| Maximum data rate | 250 | | | kbps | RE = V _{CC} , DE = V _{CC} |
| Driver input to output, t _{PLH} | 400 | 900 | 1500 | ns | Figures 2 & 9 |
| Driver input to output, t _{PHL} | 400 | 900 | 1500 | ns | Figures 2 & 9 |
| Differential driver skew | | 10 | | ns | t _{DO1} - t _{DO2} , Figures 2 and 10 |
| Driver rise or fall time | | 700 | 1000 | ns | From 10%-90%; Figures 3 and 10 |

Electrical Characteristics (Continued)

$T_{AMB} = T_{MIN}$ to T_{MAX} and $V_{CC} = 3.3V \pm 5\%$ unless otherwise noted.

| PARAMETERS | MIN. | TYP. | MAX. | UNITS | CONDITIONS |
|---|--------------|------|---------|-----------|--|
| SP3483 Driver AC Characteristics (Continued) | | | | | |
| Driver enable to output high | | 700 | 1300 | ns | Figures 4 and 11 |
| Driver enable to output low | | 690 | 1300 | ns | Figures 5 and 11 |
| Driver disable time from high | | 80 | 120 | ns | Figures 5 and 11 |
| Driver disable time from low | | 90 | 120 | ns | Figures 4 and 11 |
| SP3483 Receiver DC Characteristics | | | | | |
| Differential input threshold | -0.2 | | 0.2 | Volts | $-7V \leq V_{CM} \leq 12V$ |
| Input hysteresis | | 20 | | mV | $V_{CM} = 0V$ |
| Output voltage HIGH | $V_{CC}-0.4$ | | | Volts | $V_{ID} = 200mV, I_O = -1.5mA$ |
| Output voltage LOW | | | 0.4 | Volts | $V_{ID} = -200mV, I_O = 2.5mA$ |
| Three-state (high impedance) output current | | | ± 1 | μA | $0V \leq V_O \leq V_{CC}; \overline{RE} = V_{CC}$ |
| Input resistance | 12 | 15 | | $k\Omega$ | $-7V \leq V_{CM} \leq 12V$ |
| Input current (A, B); $V_{IN} = 12V$ | | | 1.0 | mA | $DE = 0V, V_{CC} = 0V$ or $3.6V, V_{IN} = 12V$ |
| Input current (A, B); $V_{IN} = -7V$ | | | -0.8 | mA | $DE = 0V, V_{CC} = 0V$ or $3.6V, V_{IN} = -7V$ |
| Short circuit current | 7 | | 60 | mA | $0V \leq V_{CM} \leq V_{CC}$ |
| SP3483 Receiver AC Characteristics | | | | | |
| Maximum data rate | 250 | | | kbps | $\overline{RE} = 0V, DE = 0V$ |
| Receiver input to output, t_{RPLH} | 35 | 70 | 120 | ns | Figures 6 and 12 |
| Receiver input to output, t_{RPHL} | 35 | 70 | 120 | ns | Figures 6 and 12 |
| Differential receiver skew | | 50 | | ns | $t_{RSKEW} = t_{RPHL} - t_{RPLH} $, Figures 6 and 12 |
| Receiver enable to output low | | 45 | 70 | ns | Figures 7 and 13, S_1 closed, S_2 open |
| Receiver enable to output high | | 45 | 70 | ns | Figures 7 and 13, S_2 closed, S_1 open |
| Receiver disable from low | | 45 | 70 | ns | Figures 7 and 13, S_1 closed, S_2 open |
| Receiver disable from high | | 45 | 70 | ns | Figures 7 and 13, S_2 closed, S_1 open |

Electrical Characteristics (Continued)

$T_{AMB} = T_{MIN}$ to T_{MAX} and $V_{CC} = 3.3V \pm 5\%$ unless otherwise noted

| PARAMETERS | MIN. | TYP. | MAX. | UNITS | CONDITIONS |
|--|------|------|------|---------|--|
| SP3483 Shutdown Timing | | | | | |
| Time to shutdown | 50 | 200 | 600 | ns | $\overline{RE} = 5V, DE = 0V$ |
| Driver enable from shutdown to output high | | | 2000 | ns | Figures 4 and 11 |
| Driver enable from shutdown to output low | | | 2000 | ns | Figures 5 and 11 |
| Receivers enabled from shutdown to output high | | | 2500 | ns | Figures 7 and 13, S_2 closed, S_1 open |
| Receivers enabled from shutdown to output low | | | 2500 | ns | Figures 7 and 13, S_1 closed, S_2 open |
| Power Requirements | | | | | |
| Supply current, no load | | 1000 | 2000 | μA | $\overline{RE}, DI = 0V$ or V_{CC} ; $DE = V_{CC}$ |
| Supply current, no load | | 800 | 1500 | μA | $\overline{RE} = 0V, DI = 0V$ or $V_{CC}, DE = 0V$ |
| Shutdown mode | | | 10 | μA | $DE = 0V, \overline{RE} = V_{CC}$ |

Pin Functions

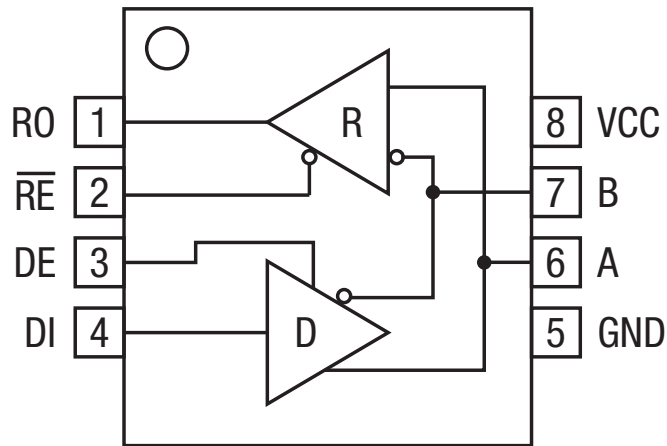

SP3483
Pinout (Top View)

| Pin Number | Pin Name | Description |
|------------|-----------------|--|
| 1 | RO | Receiver output |
| 2 | \overline{RE} | Receiver Output Enable Active LOW |
| 3 | DE | Driver Output Enable Active HIGH |
| 4 | DI | Driver Input |
| 5 | GND | Ground Connection |
| 6 | A | Non-Inverting Driver Output / Receiver Input |
| 7 | B | Inverting Driver Output / Receiver Input |
| 8 | VCC | Positive Supply |

Test Circuits

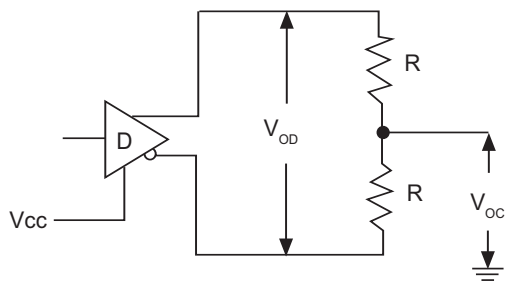

Figure 1. Driver DC Test Load Circuit

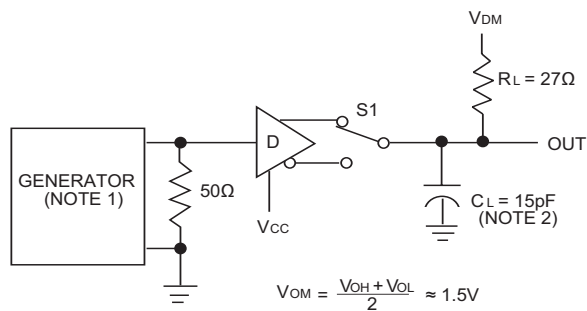

Figure 2. Driver Propagation Delay Test Circuit

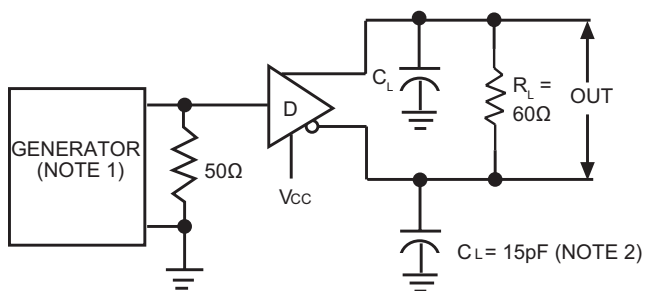

Figure 3. Driver Differential Output Delay and Transition Time Circuit.

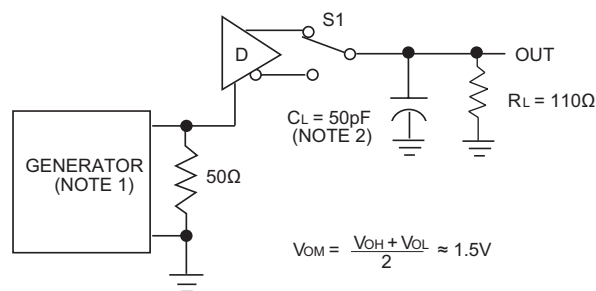

Figure 4. Driver Enable and Disable Timing Circuit, Output High

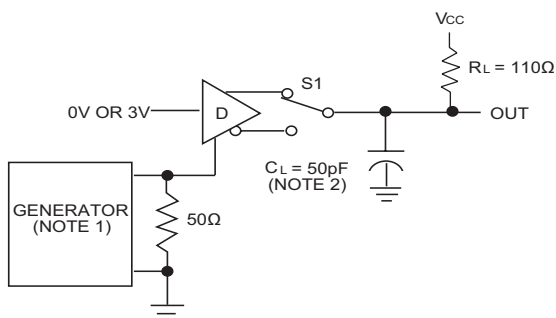

Figure 5. Driver Enable and Disable Timing Circuit, Output Low

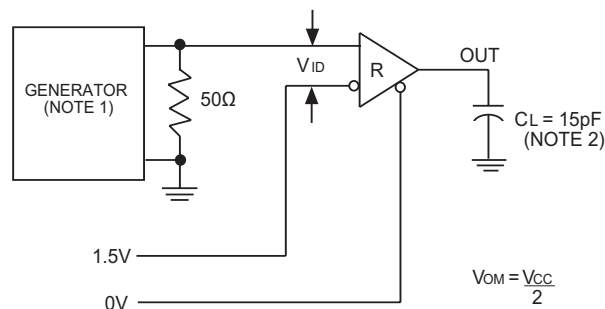

Figure 6. Receiver Propagation Delay Test Circuit

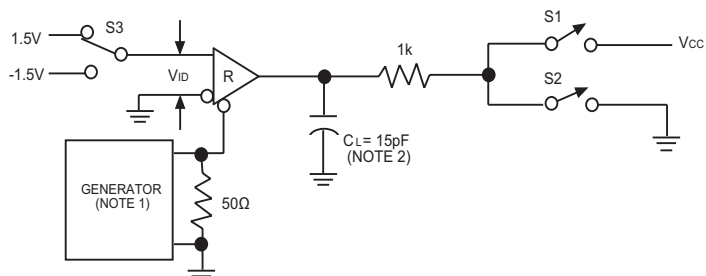

Figure 7. Receiver Enable and Disable Timing Circuit

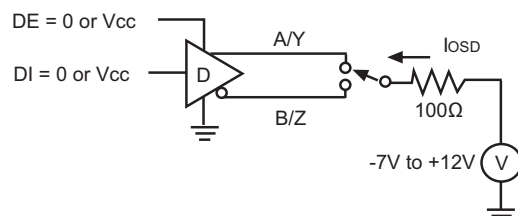

Figure 8. Driver Short Circuit Current Limit Test

Switching Waveforms

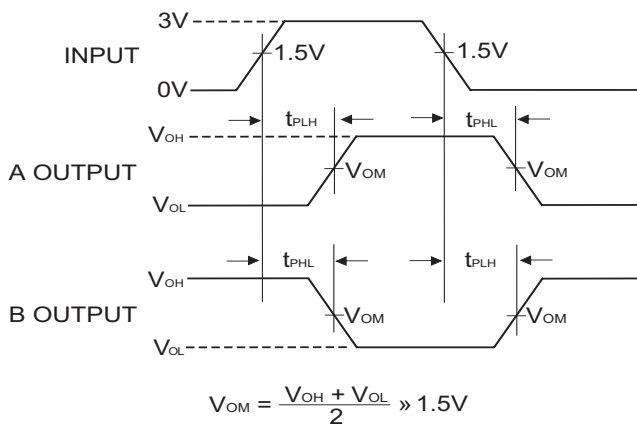

Figure 9. Driver Propagation Delay Waveforms

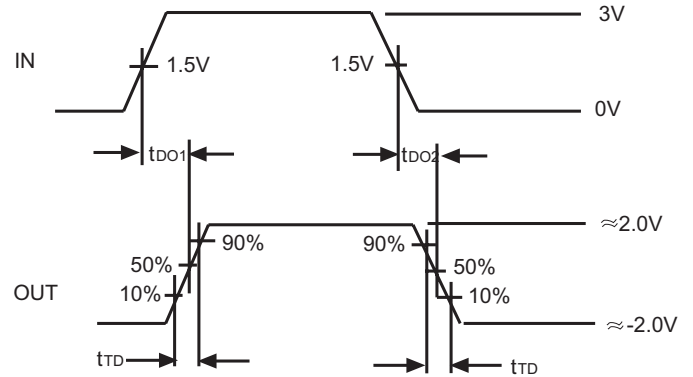

Figure 10. Driver Differential Output Delay and Transition Time Waveforms

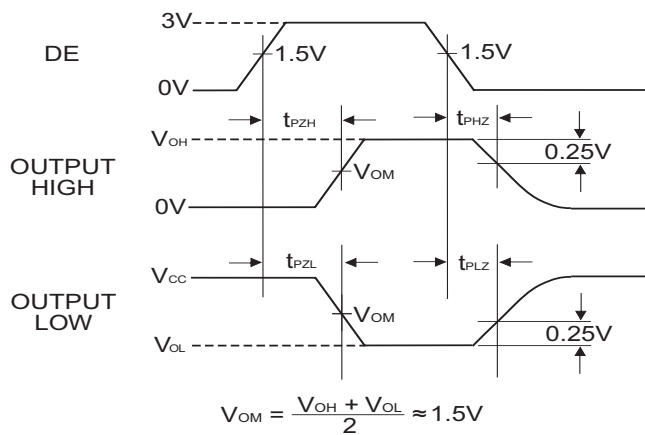

Figure 11. Driver Enable and Disable Timing Waveforms

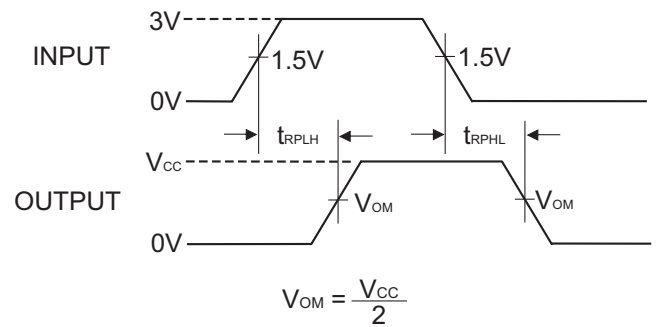

Figure 12. Receiver Propagation Delay Waveforms

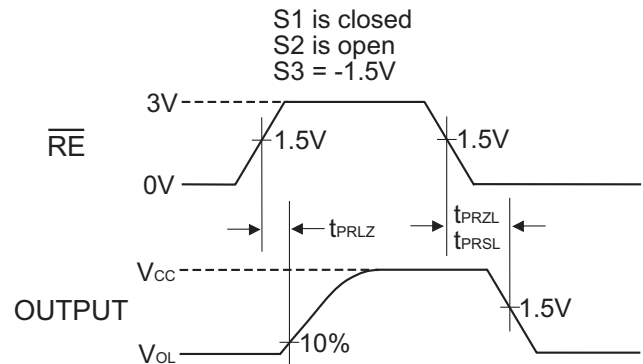
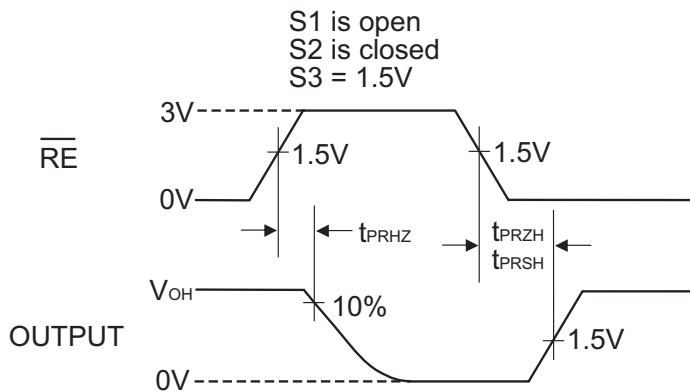

Figure 13. Receiver Enable and Disable Waveforms

NOTES

- 1: The input pulse is supplied by a generator with the following characteristics:
 PRR = 250kHz, 50% duty cycle, $t_r < 6.0ns$, $Z_O = 50\Omega$.
- 2: C_L includes probe and stray capacitance.

Description

The SP3483 device is part of a family of 3.3V low power half-duplex transceivers that meet the specifications of the RS-485 and RS-422 serial protocols. This device is pin-to-pin compatible with the MaxLinear SP483 device as well as popular industry standards. The SP3483 features MaxLinear's BiCMOS process allowing low power operation without sacrificing performance.

The RS-485 standard is ideal for multi-drop applications and for long-distance interfaces. RS-485 allows up to 32 drivers and 32 receivers to be connected to a data bus, making it an ideal choice for multi-drop applications. Since the cabling can be as long as 4,000 feet, RS-485 transceivers are equipped with a wide (-7V to +12V) common mode range to accommodate ground potential differences. Because RS-485 is a differential interface, data is virtually immune to noise in the transmission line.

Drivers

The driver outputs of the SP3483 are differential outputs meeting the RS-485 and RS-422 standards. The typical voltage output swing with no load will be 0 Volts to 3.3 Volts. With worst case loading of 54Ω across the differential outputs, the drivers can maintain greater than 1.5V voltage levels. The drivers have an enable control line which is active HIGH. A logic HIGH on DE (pin 3) will enable the differential driver outputs. A logic LOW on the DE (pin 3) will force the driver outputs into high impedance (high-Z).

The SP3483 has internally slew rate limited driver outputs to minimize EMI. The transceivers will operate up to 250kbps. The 250mA I_{SC} maximum limit on the driver output allows the SP3483 to withstand an infinite short circuit over the -7.0V to 12V common mode range without catastrophic damage to the IC.

Receivers

The SP3483 receiver has differential inputs with an input sensitivity as low as ±200mV. Input impedance of the receivers is typically 15kΩ (12kΩ minimum). A wide common mode range of -7V to 12V allows for large ground potential differences between systems. The receiver of the SP3483 has a tri-state enable control input \overline{RE} (Pin 2). A logic LOW on \overline{RE} will enable the receiver, a logic HIGH on \overline{RE} will disable the receiver.

The receiver of the SP3483 will operate up to 250kbps. The receiver is equipped with the fail-safe feature. Fail-safe guarantees that the receiver output will be in a HIGH state when the input is left unconnected (open circuit).

Shutdown Mode

The SP3483 is equipped with a Shutdown mode. To enable the shutdown state, both driver and receiver must be disabled simultaneously. A logic LOW on DE (pin 3) and a Logic HIGH on \overline{RE} (pin 2) will put the SP3483 into Shutdown mode. In Shutdown, supply current will drop to typically 1μA, 10μA maximum.

| INPUTS | | | LINE CONDITION | OUTPUTS | |
|-----------------|----|----|----------------|---------|---|
| \overline{RE} | DE | DI | | B | A |
| X | 1 | 1 | No Fault | 0 | 1 |
| X | 1 | 0 | No Fault | 1 | 0 |
| X | 0 | X | X | Z | Z |

Table 1. Transmit Function Truth Table

| INPUTS | | A - B | OUTPUTS |
|-----------------|----|-------------|---------|
| \overline{RE} | DE | | R |
| 0 | 0 | 0.2V | 1 |
| 0 | 0 | -0.2V | 0 |
| 0 | 0 | Inputs Open | 1 |
| 1 | 0 | X | Z |

Table 2. Receive Function Truth Table

Mechanical Dimensions

NSOIC8

Top View

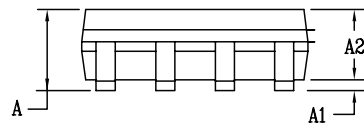

Side View

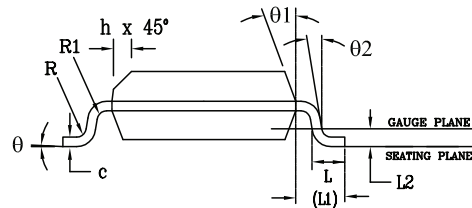

Front View

| PACKAGE OUTLINE NSOIC .150" BODY JEDEC MS-012 VARIATION AA | | | | | | |
|---|---|-----|------|---|-----|-------|
| SYMBOLS | COMMON DIMENSIONS IN MM (Control Unit) | | | COMMON DIMENSIONS IN INCH (Reference Unit) | | |
| | MIN | NOM | MAX | MIN | NOM | MAX |
| A | 1.35 | — | 1.75 | 0.053 | — | 0.069 |
| A1 | 0.10 | — | 0.25 | 0.004 | — | 0.010 |
| A2 | 1.25 | — | 1.65 | 0.049 | — | 0.065 |
| b | 0.31 | — | 0.51 | 0.012 | — | 0.020 |
| c | 0.17 | — | 0.25 | 0.007 | — | 0.010 |
| E | 6.00 BSC | | | 0.236 BSC | | |
| E1 | 3.90 BSC | | | 0.154 BSC | | |
| e | 1.27 BSC | | | 0.050 BSC | | |
| h | 0.25 | — | 0.50 | 0.010 | — | 0.020 |
| L | 0.40 | — | 1.27 | 0.016 | — | 0.050 |
| L1 | 1.04 REF | | | 0.041 REF | | |
| L2 | 0.25 BSC | | | 0.010 BSC | | |
| R | 0.07 | — | — | 0.003 | — | — |
| R1 | 0.07 | — | — | 0.003 | — | — |
| q | 0° | — | 8° | 0° | — | 8° |
| q1 | 5° | — | 15° | 5° | — | 15° |
| q2 | 0° | — | — | 0° | — | — |
| D | 4.90 BSC | | | 0.193 BSC | | |
| N | 8 | | | | | |

Drawing No: POD-00000108

Revision: A