

## Quad RS-485/RS-422 Line Drivers

- RS-485 or RS-422 Applications
- Quad Differential Line Drivers
- Tri-state Output Control
- 40ns Typical Driver Propagation Delays
- 5ns Skew
- -7V to +12V Common Mode Output Range
- 100µA Supply Current
- Single +5V Supply Operation
- Pin Compatible with SN75172, SN75174, LTC486 and LTC487

### DESCRIPTION

The **SP486** and **SP487** are low-power quad differential line drivers meeting RS-485 and RS-422 standards. The SP486 features a common driver enable control; the SP487 provides independent driver enable controls for each pair of drivers. Both feature tri-state outputs and a wide common-mode output range. SP486 and SP487 are available in a 16-pin SOIC package.

**SP487 is available, SP486 is obsolete**

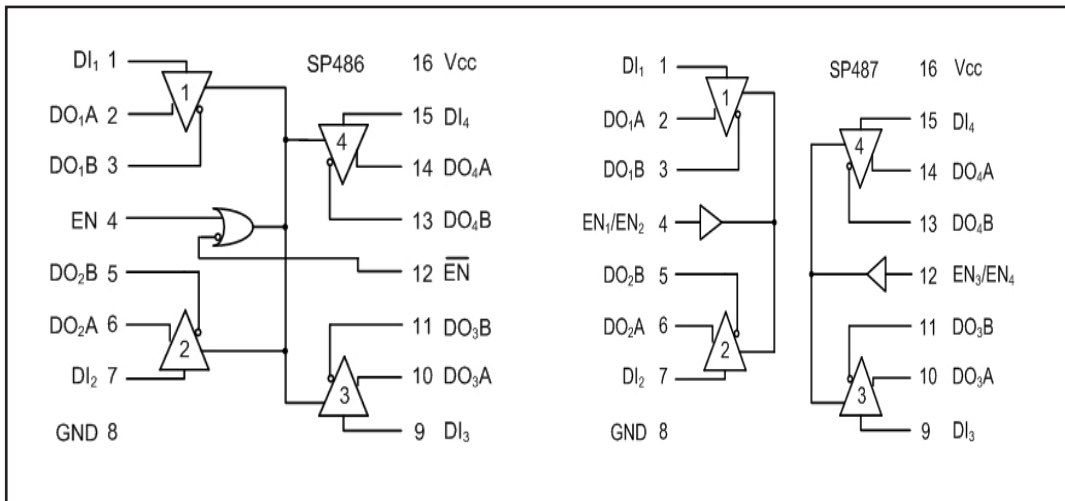

## ABSOLUTE MAXIMUM RATINGS

These are stress ratings only and functional operation of the device at these ratings or any other above those indicated in the operation sections of the specifications below is not implied. Exposure to absolute maximum rating conditions for extended periods of time may affect reliability.

V <sub>CC</sub> .....	+7V
Input Voltages	
Logic.....	-0.5V to (V <sub>CC</sub> + 0.5V)
Drivers.....	-0.5V to (V <sub>CC</sub> + 0.5V)
Driver Output Voltage.....	+/-14V
Input Currents	
Logic.....	+/-25mA
Driver.....	+/-25mA
Storage Temperature.....	-65°C to +150°C
Power Dissipation	
Plastic DIP.....	375mW
	(derate 7mW/°C above +70°C)
Small Outline.....	375mW
	(derate 7mW/°C above +70°C)

## ELECTRICAL CHARACTERISTICS

V<sub>CC</sub> = +5.0V +/-5%; typicals at 25°C; T<sub>MIN</sub> ≤ T<sub>AMB</sub> ≤ T<sub>MAX</sub> unless otherwise noted.

PARAMETERS	MIN.	TYP.	MAX.	UNITS	CONDITIONS
<b>DC CHARACTERISTICS</b>					
<b>DIGITAL INPUTS</b>					
Voltage V <sub>L</sub>			0.8	Volts	DI, EN, $\overline{\text{EN}}$ , EN <sub>1</sub> /EN <sub>2</sub> , EN <sub>3</sub> /EN <sub>4</sub>
Voltage V <sub>IH</sub>	2.0			Volts	
Input Current			+/-2	μA	V <sub>IN</sub> = 0V to V <sub>CC</sub>
<b>DRIVER OUTPUTS</b>					
Differential Voltage			5	Volts	I <sub>O</sub> = 0; unloaded
Differential Voltage	2			Volts	R <sub>L</sub> = 50Ω (RS-422); Figure 1
Differential Voltage	1.5	2	5	Volts	R <sub>L</sub> = 27Ω (RS-485); Figure 1
Change in Output Magnitude for Complementary Output state			0.2	Volts	R <sub>L</sub> = 27Ω or 50Ω; Figure 1
Common Mode Output Voltage		2.3	3	Volts	R <sub>L</sub> = 27Ω or 50Ω; Figure 1
Change in Common Mode Output Magnitude for Complementary Output state			0.2	Volts	R <sub>L</sub> = 27Ω or 50Ω; Figure 1
Driver Short Circuit Current V <sub>OH</sub>			+/-250	mA	-7V ≤ V <sub>O</sub> ≤ +10V
Driver Short Circuit Current V <sub>OL</sub>			+/-250	mA	-7V ≤ V <sub>O</sub> ≤ +10V
High Impedance Output Current		+/-2	+/-200	μA	V <sub>O</sub> = -7V to +10V
<b>POWER REQUIREMENTS</b>					
Supply Voltage	4.75		5.25	Volts	
Supply Current		0.5	10	μA	No load, output enabled
Supply Current		0.1	10	μA	No load, output disabled

## ELECTRICAL CHARACTERISTICS

$V_{CC} = +5.0V \pm 5\%$ ; typicals at 25°C;  $T_{MIN} \leq T_{AMB} \leq T_{MAX}$  unless otherwise noted.

PARAMETERS	MIN.	TYP.	MAX.	UNITS	CONDITIONS
<b>ENVIRONMENTAL AND MECHANICAL</b>					
Operating Temperature, $_C$	0		+70	°C	
Operating Temperature, $_E$	-40		+85	°C	
Storage Temperature	-65		+150	°C	
Package $_T$	16-pin SOIC				
<b>AC CHARACTERISTICS</b>					
Maximum Data Rate	10			Mbps	
Propagation Delay, $t_{PLH}$	20	40	60	ns	$R_{DIFF} = 54$ ohms, $C_{L1} = C_{L2} = 100$ pF; Figure 2
Propagation Delay, $t_{PHL}$	20	40	60	ns	$R_{DIFF} = 54$ ohms, $C_{L1} = C_{L2} = 100$ pF; Figure 2
Differential Driver Skew		5	15	ns	$R_{DIFF} = 54$ ohms, $C_{L1} = C_{L2} = 100$ pF; Figure 2
Driver Rise Time ( $t_R$ )		20		ns	10% to 90%
Driver Fall Time ( $t_F$ )		20		ns	90% to 10%
Driver Enable to output High		60	110	ns	$C_L = 100$ pF, Figures 3 and 5 ( $S2$ closed)
Driver Enable to output Low		60	115	ns	$C_L = 100$ pF, Figures 3 and 5 ( $S1$ closed)
Driver Disable from output High		60	130	ns	$C_L = 15$ pF, Figures 3 and 5 ( $S2$ closed)
Driver Disable from output Low		60	130	ns	$C_L = 15$ pF, Figures 3 and 5 ( $S1$ closed)

## SP486

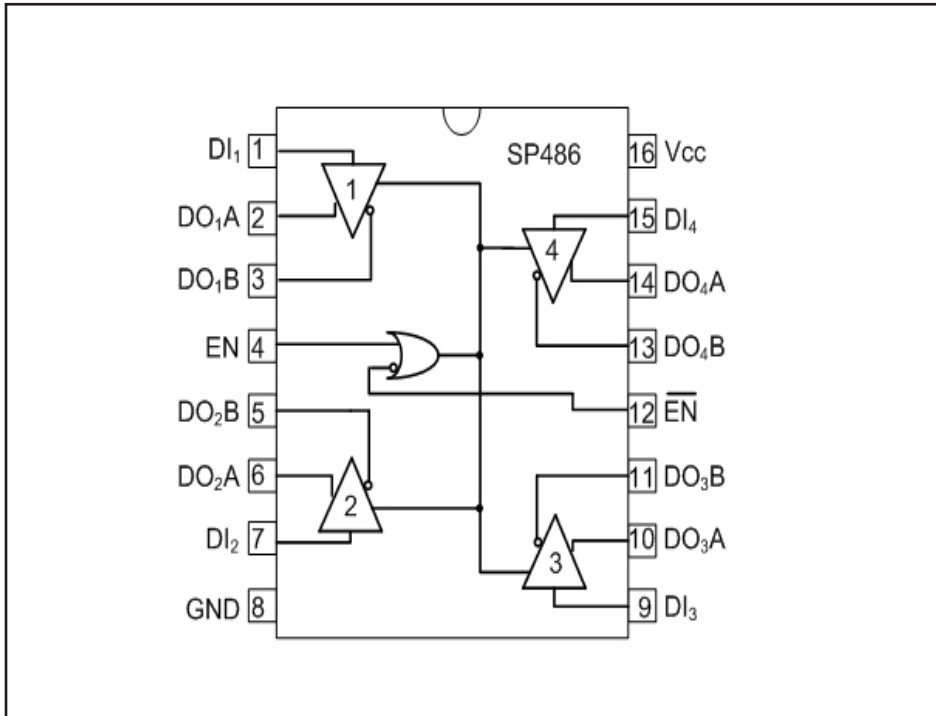

## Pin Function SP486

Pin 1 - DI<sub>1</sub> - Driver 1 Input - If driver 1 output is enabled, a logic 0 on DI<sub>1</sub> forces driver output DO<sub>1A</sub> low and DO<sub>1B</sub> high. A logic 1 on DI<sub>1</sub> with driver 1 output enabled forces driver DO<sub>1A</sub> high and DO<sub>1B</sub> low.

Pin 2 - DO<sub>1A</sub> - Driver 1 output A.

Pin 3 - DO<sub>1B</sub> - Driver 1 output B.

Pin 4 - EN - Driver Output Enable; Please refer to SP486 truth table (1).

Pin 5 - DO<sub>2B</sub> - Driver 2 output B.

Pin 6 - DO<sub>2A</sub> - Driver 2 output A.

Pin 7 - DI<sub>2</sub> - Driver 2 Input - If driver 2 output is enabled, a logic 0 on DI<sub>2</sub> forces driver output DO<sub>2A</sub> low and DO<sub>2B</sub> high. A logic 1 on DI<sub>2</sub> with driver 2 output enabled forces driver DO<sub>2A</sub> high and DO<sub>2B</sub> low.

Pin 8 - GND - Ground.

Pin 9 - DI<sub>3</sub> - Driver 3 Input - If driver 3 output is enabled, a logic 0 on DI<sub>3</sub> forces driver output DO<sub>3A</sub> low and DO<sub>3B</sub> high. A logic 1 on DI<sub>3</sub> with driver 3 output enabled forces driver DO<sub>3A</sub> high and DO<sub>3B</sub> low.

Pin 10 - DO<sub>3A</sub> - Driver 3 output A.

Pin 11 - DO<sub>3B</sub> - Driver 3 output B.

Pin 12 -  $\overline{\text{EN}}$  - Driver Output Disable; Please refer to SP486 truth table (1).

Pin 13 - DO<sub>4B</sub> - Driver 4 output B.

Pin 14 - DO<sub>4A</sub> - Driver 4 output A.

Pin 15 - DI<sub>4</sub> - Driver 4 Input - If driver 4 output is enabled, a logic 0 on DI<sub>4</sub> forces driver output DO<sub>4A</sub> low and DO<sub>4B</sub> high. A logic 1 on DI<sub>4</sub> with driver 4 output enabled forces driver DO<sub>4A</sub> high and DO<sub>4B</sub> low.

Pin 16 - Supply Voltage - +4.75V ≤ Vcc ≤ +5.25V.

## SP487

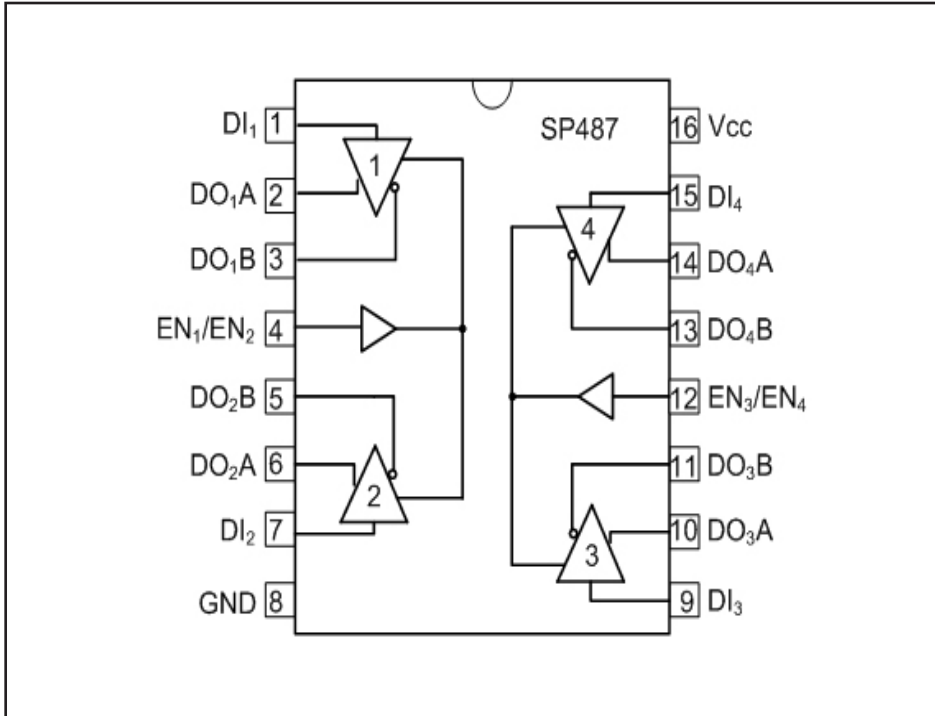
**Pin Function SP487**

Pin 1 - DI<sub>1</sub> - Driver 1 Input - If driver 1 output is enabled, a logic 0 on DI<sub>1</sub> forces driver output DO<sub>1</sub>A low and DO<sub>1</sub>B high. A logic 1 on DI<sub>1</sub> with driver 1 output enabled forces driver DO<sub>1</sub>A high and DO<sub>1</sub>B low.

Pin 2 - DO<sub>1</sub>A - Driver 1 output A.

Pin 3 - DO<sub>1</sub>B - Driver 1 output B.

Pin 4 - EN<sub>1</sub>/EN<sub>2</sub> - Driver 1 and 2 Output Enable; Please refer to SP487 truth table (2).

Pin 5 - DO<sub>2</sub>B - Driver 2 output B.

Pin 6 - DO<sub>2</sub>A - Driver 2 output A.

Pin 7 - DI<sub>2</sub> - Driver 2 Input - If driver 2 output is enabled, a logic 0 on DI<sub>2</sub> forces driver output DO<sub>2</sub>A low and DO<sub>2</sub>B high. A logic 1 on DI<sub>2</sub> with driver 2 output enabled forces driver DO<sub>2</sub>A high and DO<sub>2</sub>B low.

Pin 8 - GND - Ground.

Pin 9 - DI<sub>3</sub> - Driver 3 Input - If driver 3 output is enabled, a logic 0 on DI<sub>3</sub> forces driver output DO<sub>3</sub>A low and DO<sub>3</sub>B high. A logic 1 on DI<sub>3</sub> with driver 3 output enabled forces driver DO<sub>3</sub>A high and DO<sub>3</sub>B low.

Pin 10 - DO<sub>3</sub>A - Driver 3 output A.

Pin 11 - DO<sub>3</sub>B - Driver 3 output B.

Pin 12 - EN<sub>3</sub>/EN<sub>4</sub> - Driver 3 and 4 Output Enable; Please refer to SP487 truth table (2)..

Pin 13 - DO<sub>4</sub>B - Driver 4 output B.

Pin 14 - DO<sub>4</sub>A - Driver 4 output A.

Pin 15 - DI<sub>4</sub> - Driver 4 Input - If driver 4 output is enabled, a logic 0 on DI<sub>4</sub> forces driver output DO<sub>4</sub>A low and DO<sub>4</sub>B high. A logic 1 on DI<sub>4</sub> with driver 4 output enabled forces driver DO<sub>4</sub>A high and DO<sub>4</sub>B low.

Pin 16 - Supply Voltage -  $+4.75V \leq V_{cc} \leq +5.25V$ .

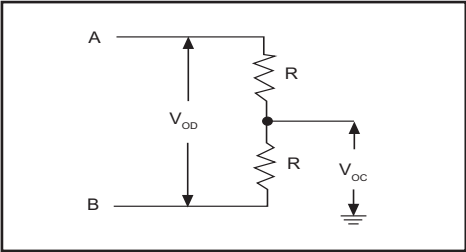

Figure 1. Driver DC Test Load

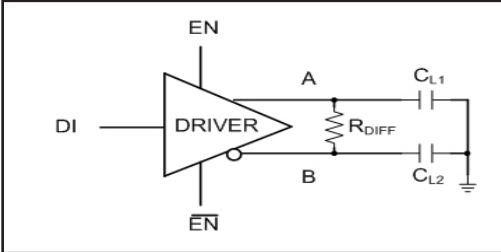

Figure 2. Driver Timing Test

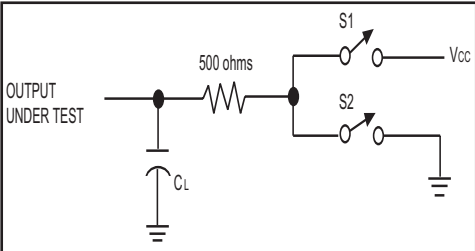

Figure 3. Driver Timing Test Load

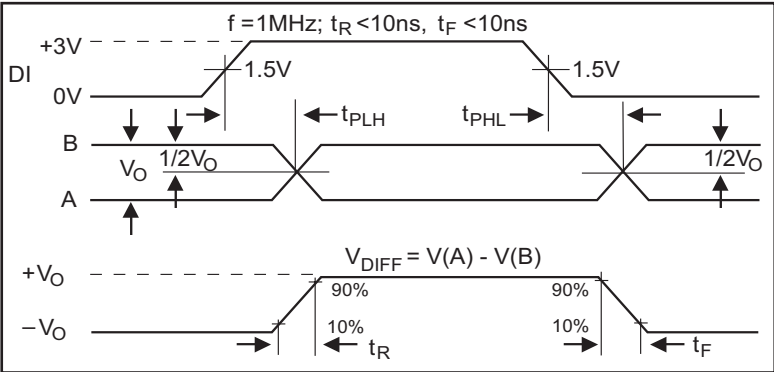

Figure 4. Driver Propagation Delays

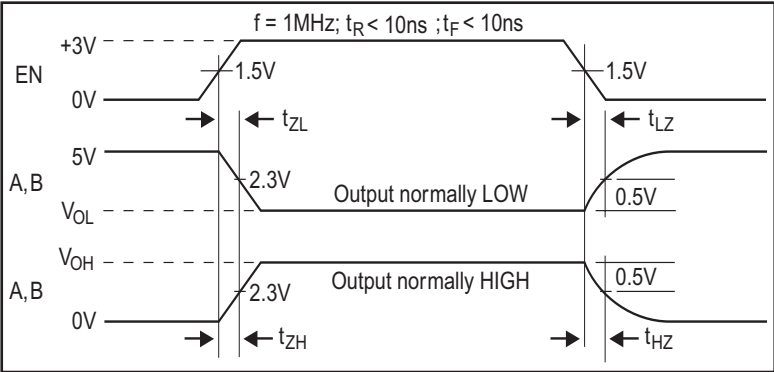

Figure 5. Driver Enable/Disable Timing

The **SP486** and **SP487** are low power quad differential line drivers meeting RS-485 and RS-422 standards. The SP486 features active high and active low common driver enable controls; the SP487 provides independent, active high driver enable controls for each pair of drivers. The driver outputs are short-circuit limited to 200mA. Data rates up to 10Mbps are supported. The SP486 and SP487 are available in a 16-pin SOIC package.

INPUT	ENABLES		OUTPUTS	
	EN	$\overline{\text{EN}}$	OUTA	OUTB
H	H	X	H	L
L	H	X	L	H
H	X	L	H	L
L	X	L	L	H
X	L	H	Hi-Z	Hi-Z

Table 1. SP486 Truth Table

INPUT	ENABLES	OUTPUTS	
	$\text{EN}_1/\text{EN}_2$ or $\text{EN}_3/\text{EN}_4$	OUTA	OUTB
H	H	H	L
L	H	L	H
X	L	Hi-Z	Hi-Z

Table 2. SP487 Truth Table

REVISION HISTORY			
REV	DESCRIPTION	DATE	APP'D
A	DRAWING ORIGINATOR	11/05/05	JL
B	DRAWING FORMAT MODIFICATION	09/13/06	JL
C	CHANGE DRAWING LOGO AND COMPANY NAME	11/21/07	JL

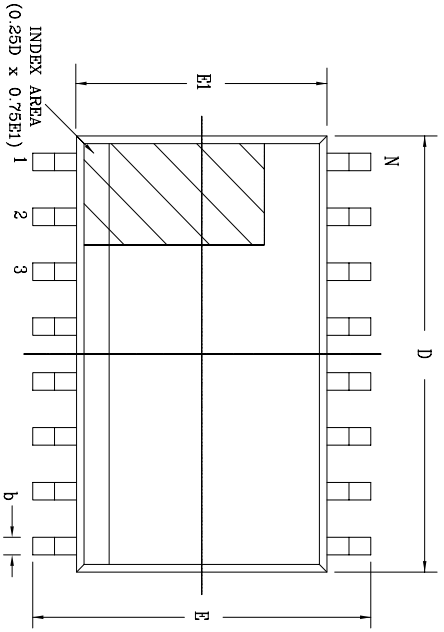

Top View

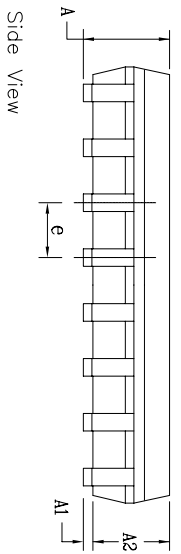

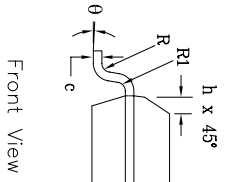

Side View

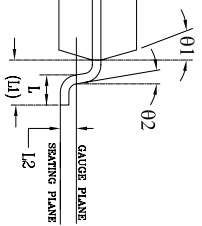

Front View

16 Pin SOICW JEDEC MS-013 Variation AA		DIMENSIONS IN MM (Control Unit)		DIMENSIONS IN INCH (Reference Unit)		
SYMBOLS	MIN	NOM	MAX	MIN	NOM	MAX
A	2.35	—	2.65	0.093	—	0.104
A1	0.10	—	0.30	0.004	—	0.012
A2	2.05	—	2.55	0.081	—	0.100
b	0.31	—	0.51	0.012	—	0.020
c	0.20	—	0.33	0.008	—	0.013
E	10.30	BSC	—	0.406	BSC	—
E1	7.50	BSC	—	0.295	BSC	—
e	1.27	BSC	—	0.050	BSC	—
h	0.25	—	0.75	0.010	—	0.030
L	0.40	—	1.27	0.016	—	0.050
L1	1.40	REF	—	0.055	REF	—
L2	0.25	BSC	—	0.010	BSC	—
R	0.07	—	—	0.003	—	—
R1	0.07	—	—	0.003	—	—
theta	0°	—	8°	0°	—	8°
theta1	5°	—	15°	5°	—	15°
theta2	0°	—	—	0°	—	—
D	10.30	BSC	—	0.405	BSC	—
N	16	—	—	16	—	—



		<b>EXAR CORPORATION</b> Providing Connectivity	
By: JL	Date: 11/21/07	Drawing No: 16-PIN SOICW PACKAGE OUTLINE	Revision: C
		16-PIN SOICW	Sheet: 1 OF 1