

Description

The SP490 is a low power differential line driver/receiver meeting RS-485 and RS-422 standards up to 5Mbps. The SP491 is identical to the SP490 with the addition of driver and receiver tri-state enable lines. Both products feature $\pm 200\text{mV}$ receiver input sensitivity, over wide common mode range. The SP490 is available in 8-pin NSOIC packages for operation over the commercial temperature range. The SP491 is available in 14-pin NSOIC packages for operation over the commercial and industrial temperature ranges.

FEATURES

- 5V only
- Low power BiCMOS
- Driver/receiver enable (SP491)
- RS-485 and RS-422 drivers/receivers
- Pin compatible with LTC490 and SN75179 (SP490)
- Pin compatible with LTC491 and SN75180 (SP491)

Ordering Information - [Back Page](#)

Block Diagrams

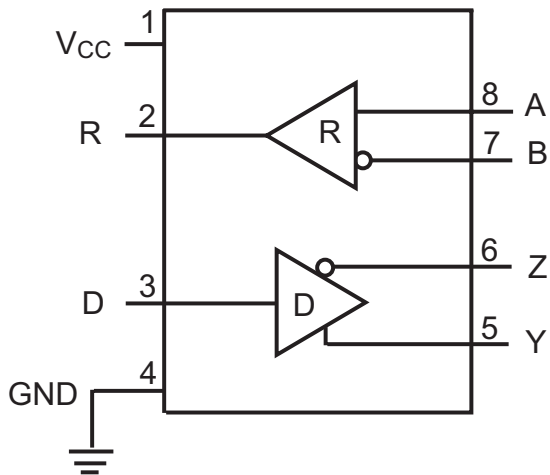

SP490

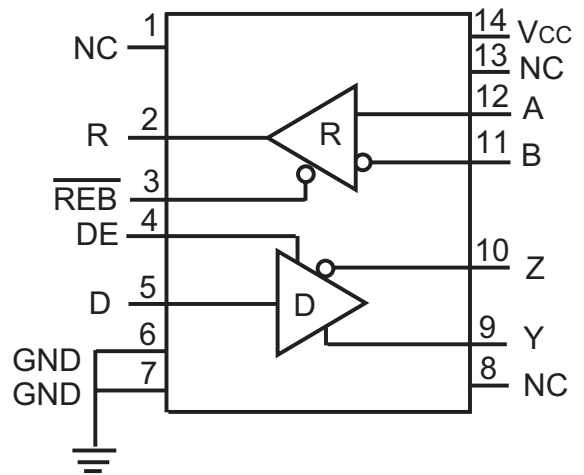

SP491

Absolute Maximum Ratings (SP490)

These are stress ratings only and functional operation of the device at these ratings or any other above those indicated in the operation sections of the specifications below is not implied. Exposure to absolute maximum rating conditions for extended periods of time may affect reliability.

V_{CC}7.0V

Input Voltages

Drivers.....-0.5V to ($V_{CC}+0.5V$)

Receivers..... $\pm 14V$

Output Voltages

Drivers..... $\pm 14V$

Receivers.....-0.5V to ($V_{CC}+0.5V$)

Storage Temperature.....-65°C to +150°C

Power Dissipation.....1000mW

Electrical Characteristics

$T_{AMB} = T_{MIN}$ to T_{MAX} and $V_{CC} = 5V \pm 5\%$ unless otherwise noted.

PARAMETERS	MIN.	TYP.	MAX.	UNITS	CONDITIONS
SP490 Driver DC Characteristics					
Differential output voltage			V_{CC}	V	Unloaded; $R = \infty\Omega$; Figure 1
Differential output voltage	2		V_{CC}	V	With load; $R = 50\Omega$ (RS-422); Figure 1
Differential output voltage	1.5		V_{CC}	V	With load; $R = 27\Omega$ (RS-485); Figure 1
Change in magnitude of driver differential output voltage for complimentary states			0.2	V	$R = 27\Omega$ or $R = 50\Omega$; Figure 1
Driver common-mode output voltage			3	V	$R = 27\Omega$ or $R = 50\Omega$; Figure 1
Input high voltage	2.0			V	Applies to D
Input low voltage			0.8	V	Applies to D
Input current			± 10	μA	Applies to D
Driver short circuit current $V_{OUT} = HIGH$			± 250	mA	$-7V \leq V_O \leq 12V$
Driver short circuit current $V_{OUT} = LOW$			± 250	mA	$-7V \leq V_O \leq 12V$
SP490 Driver AC Characteristics					
Maximum data rate	5			Mbps	
Driver input to output, t_{PLH}		30	60	ns	$R_{DIFF} = 54\Omega$, $C_{L1} = C_{L2} = 100pF$; Figures 3 & 5
Driver input to output, t_{PHL}		30	60	ns	$R_{DIFF} = 54\Omega$, $C_{L1} = C_{L2} = 100pF$; Figures 3 & 5
Driver skew		5		ns	$t_{SKEW} = t_{DPLH} - t_{DPHL} $; Figures 3 & 5
Driver rise or fall time		15	40	ns	From 10% to 90%; $R_{DIFF} = 54\Omega$, $C_{L1} = C_{L2} = 100pF$; Figures 3 & 5

Electrical Characteristics (Continued)

$T_{AMB} = T_{MIN}$ to T_{MAX} and $V_{CC} = 5V \pm 5\%$ unless otherwise noted.

PARAMETERS	MIN.	TYP.	MAX.	UNITS	CONDITIONS
SP490 Receiver DC Characteristics					
Differential input threshold	-0.2		0.2	V	$-7V \leq V_{CM} \leq 12V$
Input hysteresis		70		mV	$V_{CM} = 0V$
Output voltage HIGH	3.5			V	$V_{ID} = 200mV, I_O = -4mA$
Output voltage LOW			0.4	V	$V_{ID} = -200mV, I_O = 4mA$
Input resistance	12	15		k Ω	$-7V \leq V_{CM} \leq 12V$
Input current (A, B); $V_{IN} = 12V$			± 1.0	mA	$V_{IN} = 12V$
Input current (A, B); $V_{IN} = -7V$			-0.8	mA	$V_{IN} = -7V$
Short circuit current			85	mA	$0V \leq V_O \leq V_{CC}$
SP490 Receiver AC Characteristics					
Maximum data rate	5			Mbps	
Receiver input to output, t_{PLH}		45	150	ns	$R_{DIFF} = 54\Omega, C_{L1} = C_{L2} = 100pF$; Figures 3 and 7
Receiver input to output, t_{PHL}		45	150	ns	$R_{DIFF} = 54\Omega, C_{L1} = C_{L2} = 100pF$; Figures 3 and 7
Differential receiver skew, $ t_{PLH} - t_{PHL} $		13		ns	$R_{DIFF} = 54\Omega, C_{L1} = C_{L2} = 100pF$; Figures 3 and 7
Power Requirements					
Supply Voltage	4.75		5.25	V	
Supply Current		900		μA	
SP490 Environmental and Mechanical					
Operating Temperature					
Commercial (_C_)	0		70	$^{\circ}C$	
Storage Temperature	-65		150	$^{\circ}C$	
Package					
NSOIC (_N)					

Test Circuits

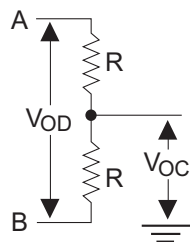

Figure 1: Driver DC Test Load Circuit

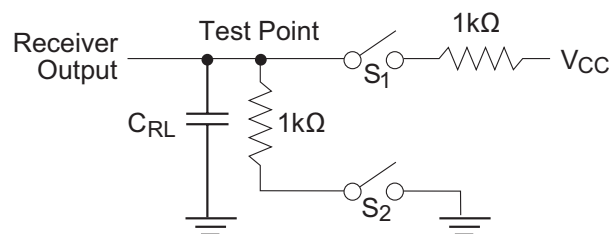

Figure 2: Receiver Timing Test Load Circuit

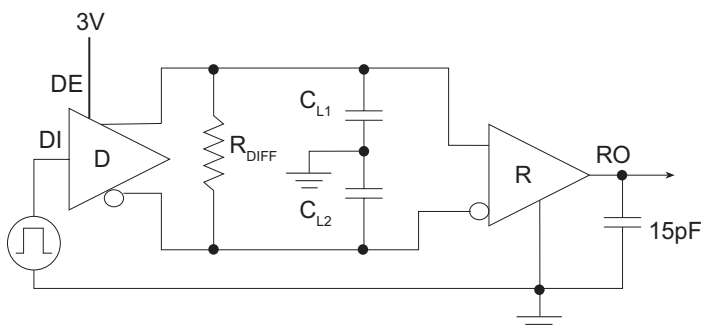

Figure 3: Driver/Receiver Timing Test Circuit

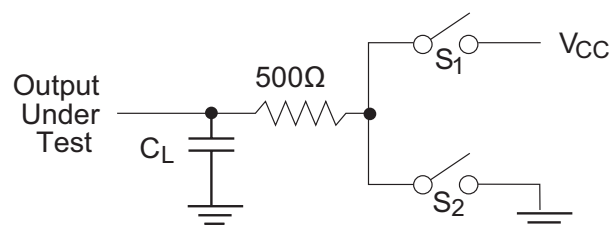

Figure 4: Driver Timing Test Load #2 Circuit

Switching Waveforms

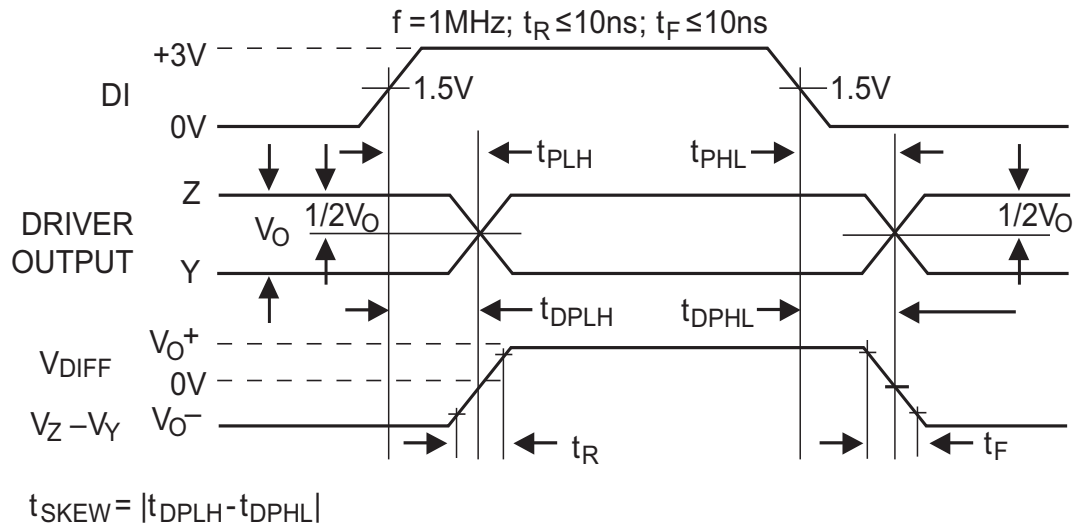

Figure 5: Driver Propagation Delays

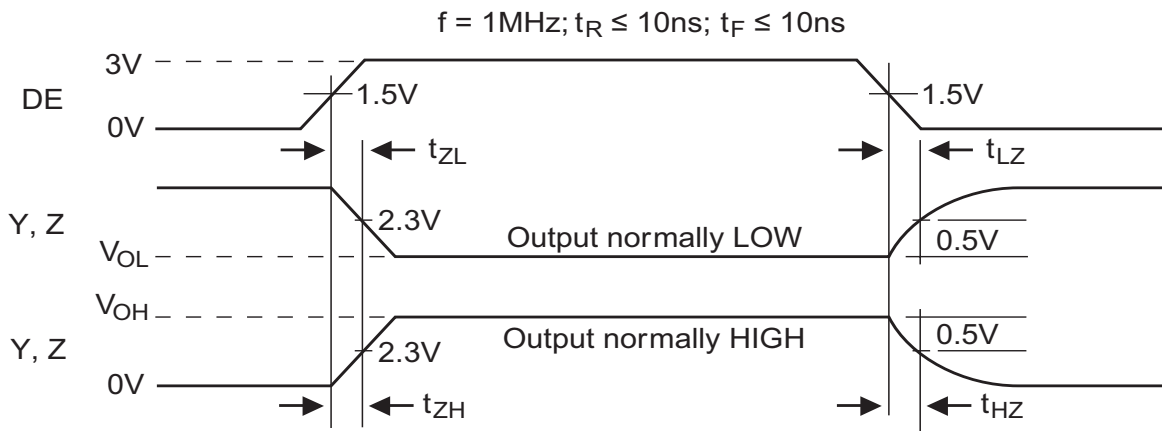

Figure 6: Driver Enable and Disable Times

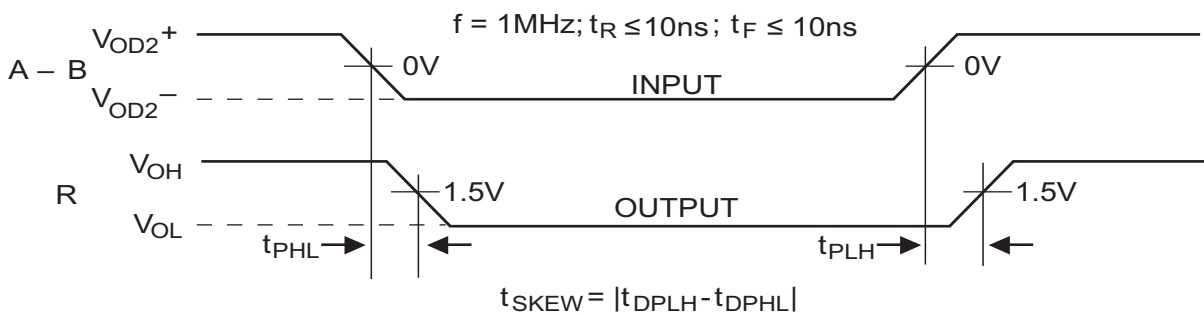

Figure 7: Receiver Propagation Delays

Absolute Maximum Ratings (SP491)

These are stress ratings only and functional operation of the device at these ratings or any other above those indicated in the operation sections of the specifications below is not implied. Exposure to absolute maximum rating conditions for extended periods of time may affect reliability.

V_{CC}.....7.0V

Input Voltages

Logic.....-0.5V to (V_{CC}+0.5V)

Drivers.....-0.5V to (V_{CC}+0.5V)

Receivers.....±14V

Output Voltages

Logic.....-0.5V to (V_{CC}+0.5V)

Drivers.....±14V

Receivers.....-0.5V to (V_{CC}+0.5V)

Storage Temperature.....-65°C to +150°C

Power Dissipation.....1000mW

Electrical Characteristics

T_{AMB} = T_{MIN} to T_{MAX} and V_{CC} = 5V ±5% unless otherwise noted

PARAMETERS	MIN.	TYP.	MAX.	UNITS	CONDITIONS
SP491 Driver DC Characteristics					
Differential output voltage			V _{CC}	V	Unloaded; R = ∞Ω ; Figure 1
Differential output voltage	2		V _{CC}	V	With load; R = 50Ω (RS-422); Figure 1
Differential output voltage	1.5		V _{CC}	V	With load; R = 27Ω (RS-485); Figure 1
Change in magnitude of driver differential output voltage for complimentary states			0.2	V	R = 27Ω or R = 50Ω; Figure 1
Driver common-mode output voltage			3	V	R = 27Ω or R = 50Ω; Figure 1
Input high voltage	2.0			V	Applies to DE, D, $\overline{\text{REB}}$
Input low voltage			0.8	V	Applies to DE, D, $\overline{\text{REB}}$
Input current			±10	μA	Applies to DE, D, $\overline{\text{REB}}$
Driver short circuit current V _{OUT} = HIGH			±250	mA	-7V ≤ V _O ≤ 12V
Driver short circuit current V _{OUT} = LOW			±250	mA	-7V ≤ V _O ≤ 12V

Electrical Characteristics, Continued

 $T_{AMB} = T_{MIN}$ to T_{MAX} and $V_{CC} = 5V \pm 5\%$ unless otherwise noted

PARAMETERS	MIN.	TYP.	MAX.	UNITS	CONDITIONS
SP491 Driver AC Characteristics					
Maximum data rate	5			Mbps	$\overline{REB} = 5V, DE = 5V$
Driver input to output, t_{PLH}		30	60	ns	$R_{DIFF} = 54\Omega, C_{L1} = C_{L2} = 100pF$; Figures 3 & 5
Driver input to output, t_{PHL}		30	60	ns	$R_{DIFF} = 54\Omega, C_{L1} = C_{L2} = 100pF$; Figures 3 & 5
Driver skew		5	10	ns	$t_{SKEW} = t_{DPLH} - t_{DPHL} $; Figures 3 & 5
Driver rise or fall time		15	40	ns	From 10%-90%; $R_{DIFF} = 54\Omega, C_{L1} = C_{L2} = 100pF$; Figures 3 & 5
Driver enable to output HIGH		40	70	ns	$C_{L1} = C_{L2} = 100pF$; Figures 4 & 6, S_2 closed
Driver enable to output LOW		40	70	ns	$C_{L1} = C_{L2} = 100pF$; Figures 4 & 6, S_1 closed
Driver disable time from LOW		40	70	ns	$C_{L1} = C_{L2} = 100pF$; Figures 4 & 6, S_1 closed
Driver disable time from HIGH		40	70	ns	$C_{L1} = C_{L2} = 100pF$; Figures 4 & 6, S_2 closed
SP491 Receiver DC Characteristics					
Differential input threshold	-0.2		0.2	Volts	$-7V \leq V_{CM} \leq 12V$
Input hysteresis		70		mV	$V_{CM} = 0V$
Output voltage HIGH	3.5			Volts	$V_{ID} = 200mV, I_O = -4mA$
Output voltage LOW			0.4	Volts	$V_{ID} = -200mV, I_O = 4mA$
Three-State (High Impedance) Output Current			± 1	μA	$0.4V \leq V_O \leq 2.4V; \overline{REB} = 5V$
Input resistance	12	15		k Ω	$-7V \leq V_{CM} \leq 12V$
Input current (A, B); $V_{IN} = 12V$			± 1.0	mA	$DE = 0V, V_{CC} = 0V$ or $5.25V, V_{IN} = 12V$
Input current (A, B); $V_{IN} = -7V$			-0.8	mA	$DE = 0V, V_{CC} = 0V$ or $5.25V, V_{IN} = -7V$
Short circuit current			85	mA	$0V \leq V_O \leq V_{CC}$
SP491 Receiver AC Characteristics					
Maximum data rate	5			Mbps	$\overline{REB} = 0V$
Receiver input to output, t_{PLH}	20	45	150	ns	$R_{DIFF} = 54\Omega, C_{L1} = C_{L2} = 100pF$; Figures 3 & 7
Receiver input to output, t_{PHL}	20	45	150	ns	$R_{DIFF} = 54\Omega, C_{L1} = C_{L2} = 100pF$; Figures 3 & 7
Differential receiver skew		13		ns	$ t_{PLH} - t_{PHL} ; R_{DIFF} = 54\Omega, C_{L1} = C_{L2} = 100pF$; Figures 3 & 7
Receiver enable to output LOW		45	70	ns	$C_{RL} = 15pF$; Figures 2 & 8; S_1 closed
Receiver enable to output HIGH		45	70	ns	$C_{RL} = 15pF$; Figures 2 & 8; S_2 closed
Receiver disable time from LOW		45	70	ns	$C_{RL} = 15pF$; Figures 2 & 8; S_1 closed
Receiver disable time from HIGH		45	70	ns	$C_{RL} = 15pF$; Figures 2 & 8; S_2 closed

Electrical Characteristics, Continued

$T_{AMB} = T_{MIN}$ to T_{MAX} and $V_{CC} = 5V \pm 5\%$ unless otherwise noted

PARAMETERS	MIN.	TYP.	MAX.	UNITS	CONDITIONS
Power Requirements					
Supply voltage	4.75		5.25	V	
Supply current		900		μA	\overline{REB} , D = 0V or V_{CC} ; DE = V_{CC}
SP491 Environmental and Mechanical					
Operating Temperature					
Commercial (_C_)	0		70	$^{\circ}C$	
Industrial (_E_)	-40		85	$^{\circ}C$	
Storage Temperature	-65		150	$^{\circ}C$	
Package					
NSOIC (_N)					

Switching Waveforms

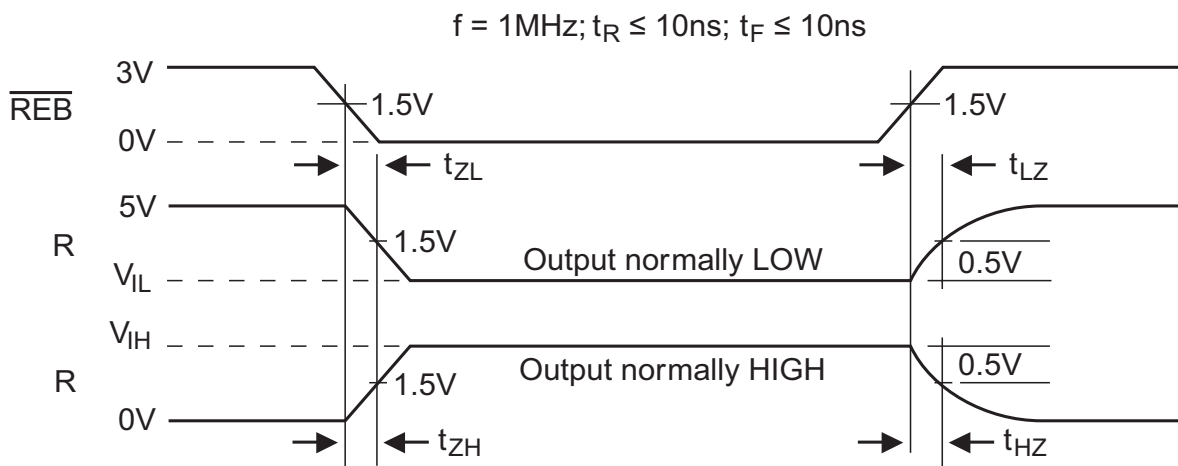
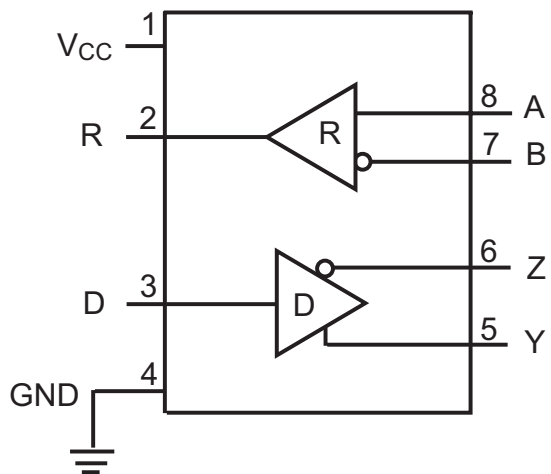

Figure 8: Receiver Enable and Disable Times

Pin Functions



SP490
Pinout (Top View)

Pin Number	Pin Name	Description
1	V _{CC}	Positive supply
2	R	Receiver output
3	D	Driver Input
4	GND	Ground connection
5	Y	Non-inverting driver output
6	Z	Inverting driver output
7	B	Inverting receiver Input
8	A	Non-inverting receiver input

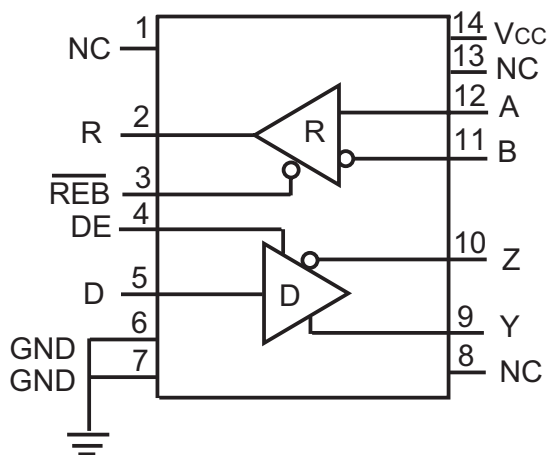

SP491
Pinout (Top View)

Pin Number	Pin Name	Description
1	NC	No connect
2	R	Receiver output
3	$\overline{\text{REB}}$	Receiver output enable active LOW
4	DE	Driver output enable active HIGH
5	D	Driver input
6	GND	Ground connection
7	GND	Ground connection
8	NC	No connect
9	Y	Non-inverting driver output
10	Z	Inverting driver output
11	B	Inverting receiver input
12	A	Non-Inverting receiver input
13	NC	No connect
14	V _{CC}	Positive supply

Description

The SP490 and SP491 are full-duplex differential transceivers that meet the requirements of RS-485 and RS-422. Fabricated with a MaxLinear proprietary BiCMOS process, both products require a fraction of the power of older bipolar designs.

The RS-485 standard is ideal for multi-drop applications or for long-distance interfaces. RS-485 allows up to 32 drivers and 32 receivers to be connected to a data bus, making it an ideal choice for multi-drop applications. Since the cabling can be as long as 4,000 feet, RS-485 transceivers are equipped with a wide (-7V to 12V) common mode range to accommodate ground potential differences. Because RS-485 is a differential interface, data is virtually immune to noise in the transmission line.

Drivers

The drivers for both the SP490 and SP491 have differential outputs. The typical voltage output swing with no load will be 0 volts to +5 volts. With worst case loading of 54Ω across the differential outputs, the driver can maintain greater than 1.5V voltage levels.

The driver of the SP491 has a driver enable control line which is active high. A logic high on DE (pin 4) of the SP491 will enable the differential driver outputs. A logic low on DE (pin 4) of the SP491 will tri-state the driver outputs. The SP490 does not have a driver enable.

Receivers

The receivers for both the SP490 and SP491 have differential inputs with an input sensitivity as low as $\pm 200\text{mV}$. Input impedance of the receivers is typically $15\text{k}\Omega$ ($12\text{k}\Omega$ minimum). A wide common mode range of -7V to 12V allows for large ground potential differences between systems. The receivers for both the SP490 and SP491 are equipped with the fail-safe feature. Fail-safe guarantees that the receiver output will be in a high state when the input is left unconnected.

The receiver of the SP491 has a receiver enable control line which is active low. A logic low on $\overline{\text{REB}}$ (pin 3) of the SP491 will enable the differential receiver. A logic high on $\overline{\text{REB}}$ (pin 3) of the SP491 will tri-state the receiver.

Mechanical Dimensions

NSOIC14

Top View

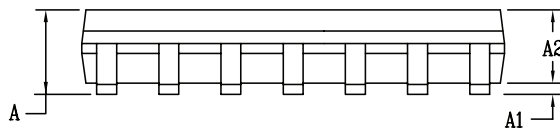
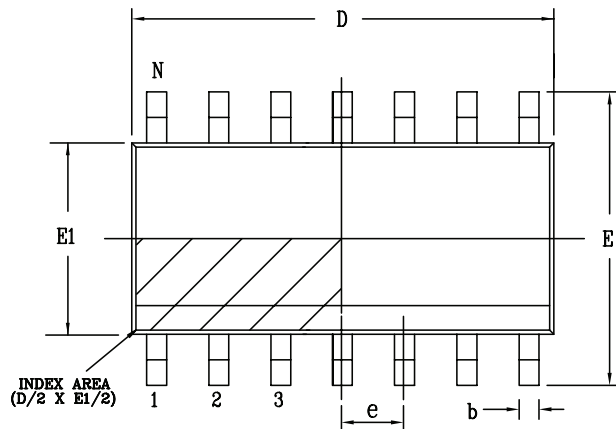

Side View

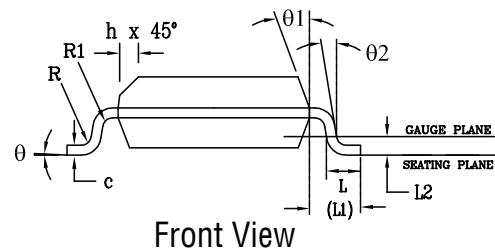

Front View

PACKAGE OUTLINE NSOIC .150" BODY JEDEC MS-012 VARIATION AB						
SYMBOLS	COMMON DIMENSIONS IN MM (Control Unit)			COMMON DIMENSIONS IN INCH (Reference Unit)		
	MIN	NOM	MAX	MIN	NOM	MAX
A	1.35	—	1.75	0.053	—	0.069
A1	0.10	—	0.25	0.004	—	0.010
A2	1.25	—	1.65	0.049	—	0.065
b	0.31	—	0.51	0.012	—	0.020
c	0.17	—	0.25	0.007	—	0.010
E	6.00 BSC			0.236 BSC		
E1	3.90 BSC			0.154 BSC		
e	1.27 BSC			0.050 BSC		
h	0.25	—	0.50	0.010	—	0.020
L	0.40	—	1.27	0.016	—	0.050
L1	1.04 REF			0.041 REF		
L2	0.25 BSC			0.010 BSC		
R	0.07	—	—	0.003	—	—
R1	0.07	—	—	0.003	—	—
q	0°	—	8°	0°	—	8°
q1	5°	—	15°	5°	—	15°
q2	0°	—	—	0°	—	—
D	8.65 BSC			0.341 BSC		
N	14					

Drawing No: POD-00000109

Revision: A