

## SMART Position Sensor, 100° and 180° Arc Configurations Superior Measurement. Accurate. Reliable. Thinking.



### DESCRIPTION

The Honeywell SMART Arc Position Sensor is one of the most durable, adaptable, lightweight, and non-contact position sensors available, enabling absolute position sensing with enhanced accuracy. This simple, robust, arc position sensor offers an IP69K sealed package, eliminating mechanical failure mechanisms, reducing wear and tear, improving reliability and durability, and minimizing downtime.

The SMART Arc Position Sensor is a non-contact sensing solution, providing highly accurate motion control and improving operation efficiency and safety. This Honeywell position sensor utilizes magnetoresistive technology to detect the position of a magnet relative to the sensor in one of two available sensing ranges:

0° to 100°

0° to 180°

Why is the SMART Position Sensor smart? SMART means that this is a sensor that can essentially think for itself. SMART Position Sensors provide a self-diagnostics feature and data gathering for enhanced reliability and closed-loop feedback control.

### VALUE PROPOSITIONS (★ = competitive differentiator)

- ★ **Reliable, durable:** Non-contact design reduces wear and tear, improving reliability and durability, minimizing downtime
- ★ **Easy to install:** Installation takes four steps (1: position device; 2: drill holes; 3: mount sensor; 4: locate magnet/connect sensor) vs. up to 14 steps some competitive products require, simplifying installation and reducing set-up costs
- **Rugged:** Honeywell utilizes unique package materials with no moving parts within the sensor, making it resistant to vibration, shock, and extreme temperatures
- ★ **Flexible:** Air gap tolerance of 7,8 ±2,5 mm [0.307 ±0.098 in] or 9,2 ±2,5 mm [0.36 ±0.09 in] (100°) and 8,5 ±2,5 mm [0.338 ±0.098 in] (180°) between sensor and magnet expands application use
- ★ **Cost effective:** Adaptable, non-contacting design allows customers to eliminate unnecessary connections for installation, reducing installation steps/time and components
- **Accurate:** 100° configuration accurately measures values down to 0.06° while the 180° configuration accurately measures values down to 0.11°
- ★ **Adaptable:** Electronics on board allow for flexible packaging and component compatibility with existing systems
- ★ **Lightweight:** Lighter in weight than optical encoders
- ★ **Self-diagnostics feature** can reduce equipment downtime by providing predictive maintenance input
- **Combined patented MR sensor and ASIC technology** provide enhanced differentiation and performance
- **IP67, IP69K sealing** allow use in many harsh applications
- **RoHS-compliant** materials meet Directive 2002/95/EC

These devices use a patented combination of an ASIC (Application-Specific Integrated Circuit) and an array of MR (magnetoresistive) sensors to accurately and reliably determine the position of a magnet attached to a moving object so that the object's position can be determined or controlled.

The MR array measures the output of the MR sensors mounted along the magnet's direction of travel. The output and the MR sensor sequence determine the nearest pair of MR sensors to the center of the magnet location. The output of these two MR sensors is then used to determine the position of the magnet between them.

With this sensor, Honeywell has utilized MR technology through the ASIC at a level never before accomplished.

Other configurations are in development.

# SMART Position Sensor

## POTENTIAL APPLICATIONS

### Transportation

- Aerial work lift platform, front end loader and digger/excavator boom position
- Scissor lift position
- Refuse truck lift and automatic reach arm position
- Mobile crane steering
- Timber harvester/processor equipment cutter arm angle
- On-board loader weighing system position

### Industrial

- Telescoping conveyor elevation
- Power generation contact angle
- Rail-road crossing arms position

### Military

- Remote weapon systems elevation
- Chassis suspension systems position height
- Military vehicle door position

### Aerospace:

- Ground-based solar panels elevation and azimuth
- Ground-based satellite dish elevation and azimuth

### Medical:

- Robotically-assisted surgery equipment position
- Patient bed elevation

For more information on these potential applications, please see the application note "[SMART Position Sensor, 100° and 180° Arc Configurations](#)".

Table 1. Specifications

Characteristic	Component	Parameter						
		100° Arc				180° Arc		
		SPS-A100D-HAMS	SPS-A100D-VAMS	SPS-A100D-HAWS	SPS-A100X-LAAS0401	SPS-A180D-HAMS	SPS-A180D-VAMS	
Sensing range	sensor only	0° to 100°				0° to 180°		
Sensing location on arc		inside			outside	inside		
Resolution		0.06°				0.11°		
Supply voltage		6 Vdc to 24 Vdc	18 Vdc to 40 Vdc	6 Vdc to 24 Vdc	5 Vdc	6 Vdc to 24 Vdc	18 Vdc to 40 Vdc	
Output		0.5 Vdc to 4.5 Vdc (10% to 90% of 5 Vdc)						
Supply current		45 mA max.			30 mA max.	45 mA max.		
Linearity		±0.4% full scale output						
Reverse polarity		26.4 Vdc	40 Vdc	26.4 Vdc	N/A	26.4 Vdc	40 Vdc	
Sensitivity		40 mV/° ±4% FS				22.22 mV/° ±4% FS		
Measurement frequency		312 Hz typ.						
Termination		4-pin M12 connector		18 AWG flying leads	Ampseal 16 connector (p/n 776536)	4-pin M12 connector		
Operating temperature		sensor and magnet actuator	-40 °C to 85 °C [-40 °F to 185 °F]					
Storage temperature	-40 °C to 150 °C [-40 °F to 302 °F]							
Air gap	7,8 ±2,5 mm [0.307 ±0.098 in]			9,2 ±2,5 mm [0.36 ±0.09 in]	8,58 ±2,5 mm [0.338 ±0.098 in]			
Sealing	IP67, IP69K							
Shock	50 G half sine wave with 11 ms duration							
Vibration	20 G from 10 Hz to 2000 Hz							
Housing material	thermoplastic							
Approvals	CE							
Mounting: screws recommended torque	M6 or 1/4-20 6 N m to 8 N m [53.1 in lb to 70.8 in lb]							
Material	magnet actuator only		neodymium					
Strength			10,000 Gauss					

### Notes:

- Tolerance applies for full sense range.
- Device used to read analog output must have input impedance greater than 1 MOhm.
- The output voltage outside of the valid measurement range will be indeterminate.
- Percent linearity is the quotient of the measured output deviation from the best fit line at the measured temperature to the full scale output span.
- Mating connector: 776536-1.

### NOTICE

Ferrous metal within a 100 mm [3.9 in] radius of the magnet may affect sensor performance.

# 100° and 180° Arc Configurations

Figure 1. Dimensional Drawings (For reference only: mm/[in].)

## SPS-A100D-HAMS, SPS-A100D-VAMS

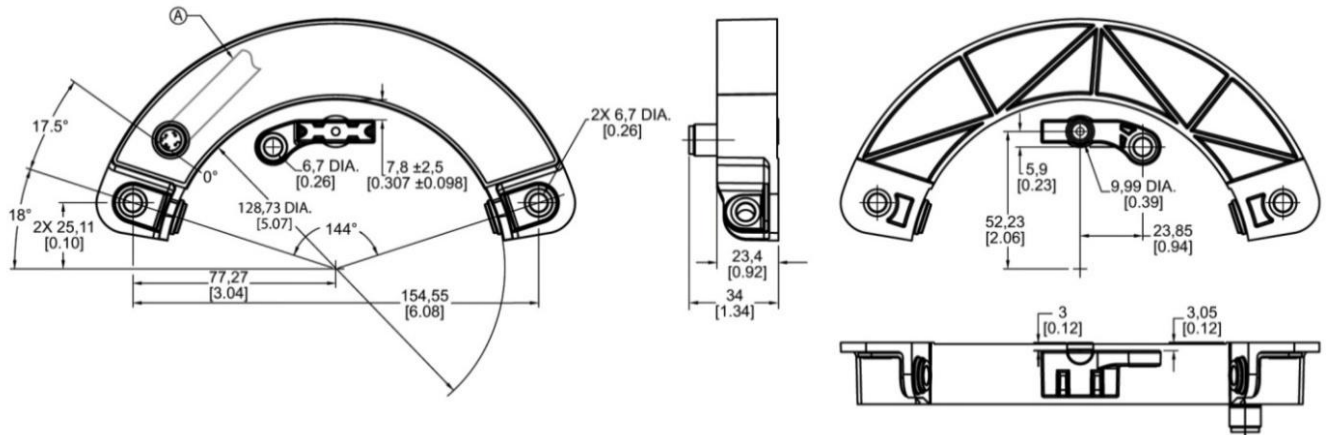

## SPS-A100D-HAWS

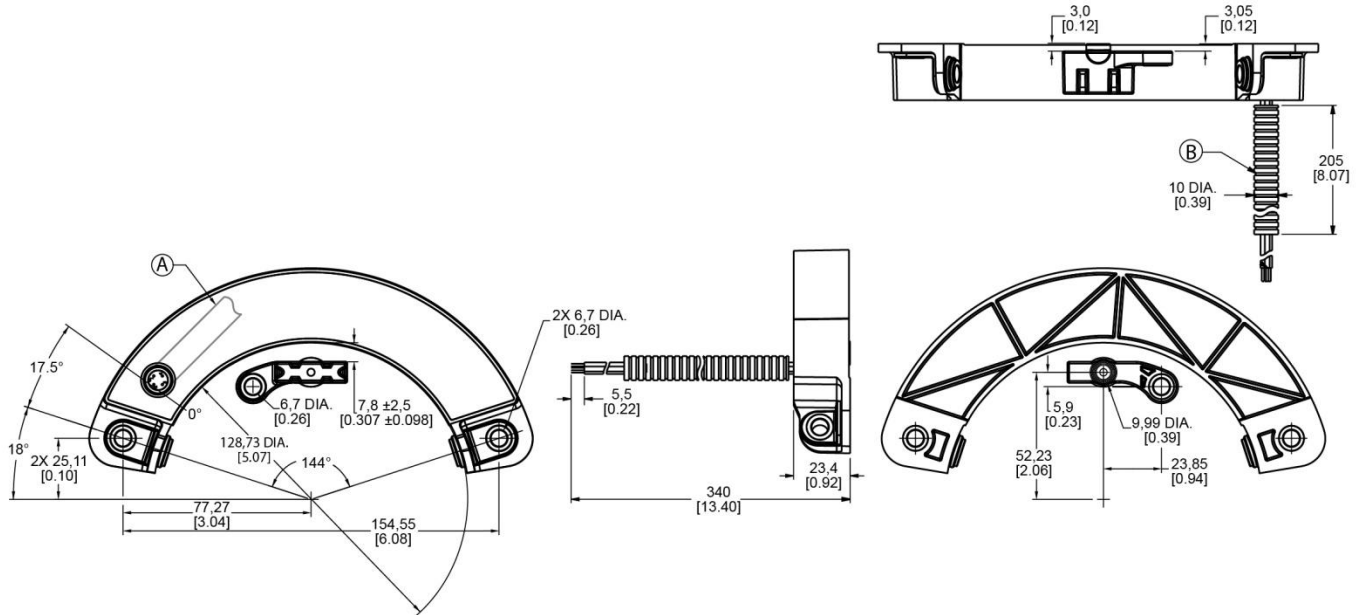

A = Cable direction for right angle connector

B = Polyethylene conduit

# SMART Position Sensor

Figure 1. Dimensional Drawings (For reference only: mm/[in], continued.)

SPS-A100X-LAAS0401

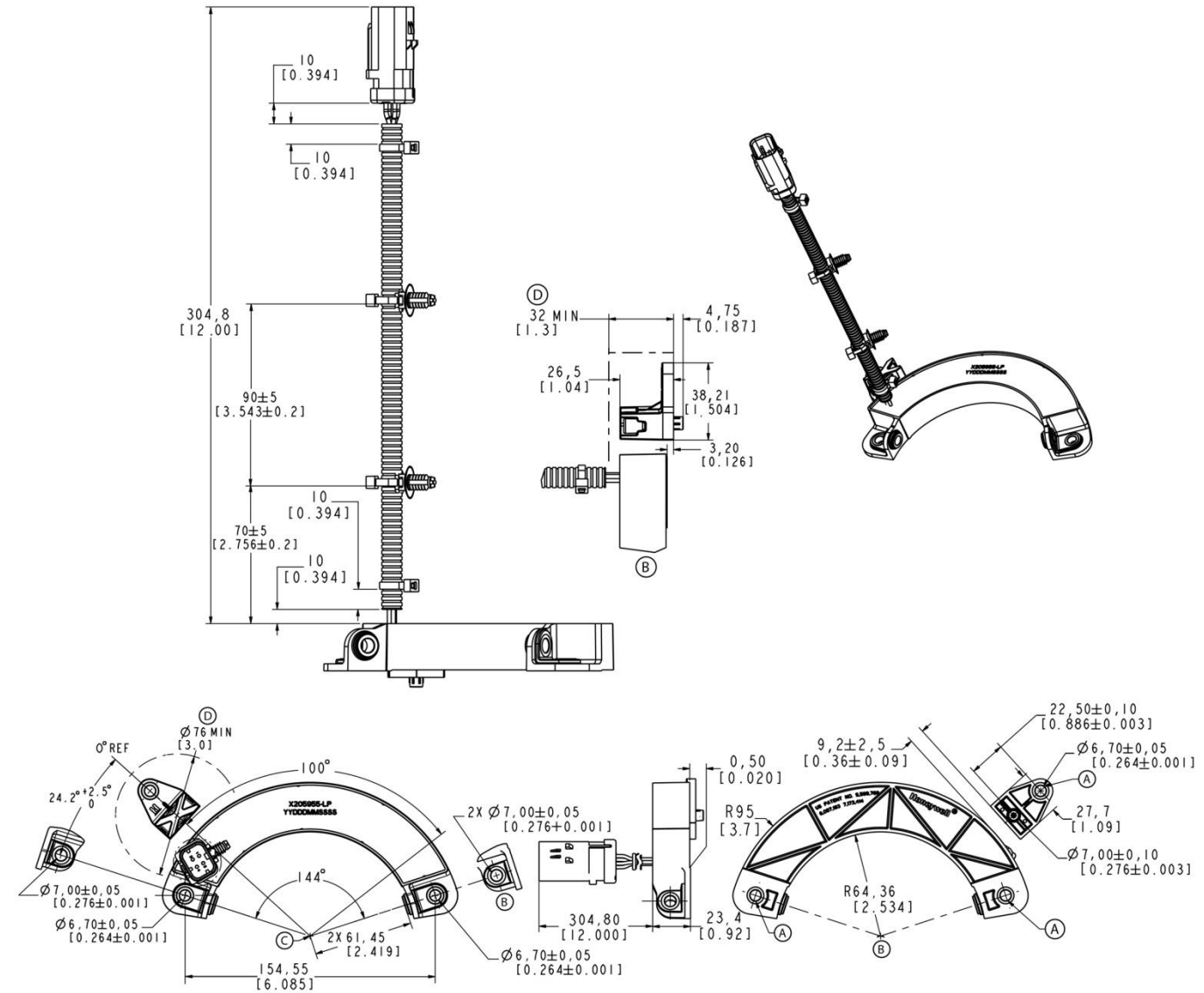

- A = Magnet pin locating hole
- B = Partial view
- C = Rotating axis center
- D = Magnetic sensitive zone: protect with a non-ferrous metal shield

# 100° and 180° Arc Configurations

Figure 1. Dimensional Drawings (For reference only: mm/[in], continued.)

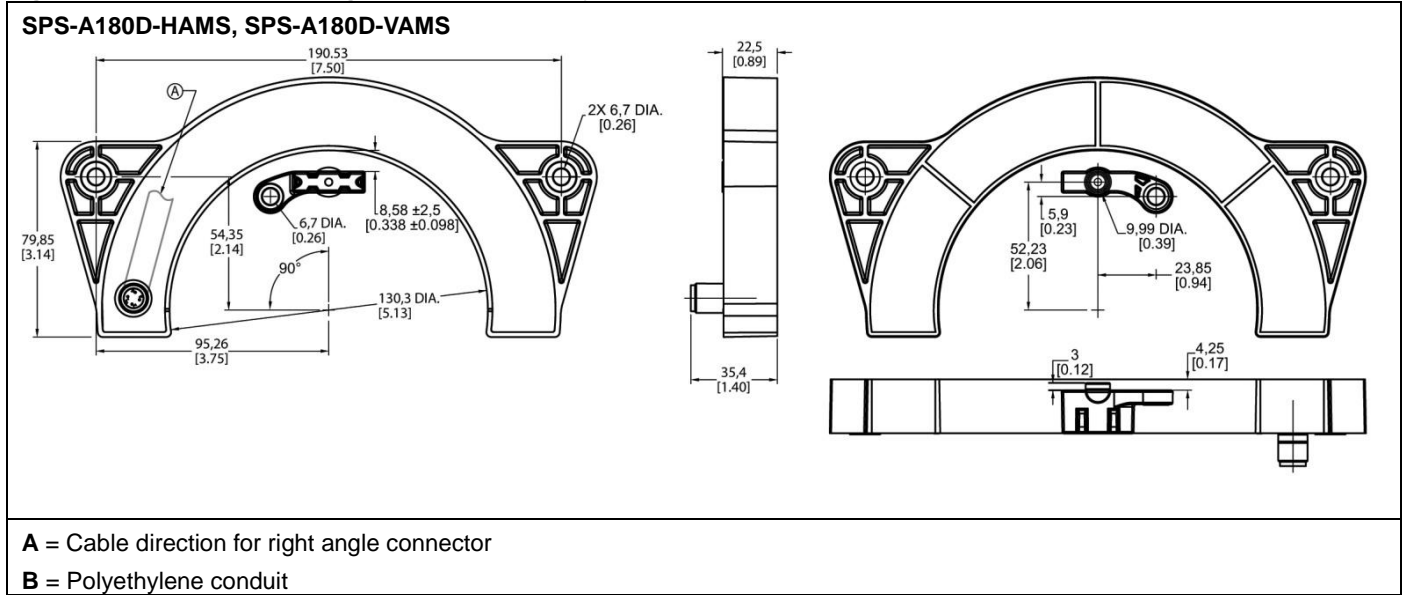

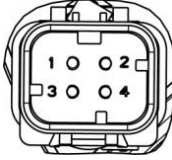

Figure 2. Connections

4 Pin M12 Connector	Ampseal 16 Connector (p/n 776536)	18 AWG Flying Leads
<p>SPS-A100D-HAMS, SPS-A100D-VAMS                      SPS-A180D-HAMS, SPS-A180D-VAMS</p>	<p>SPS-A100X-LAAS0401</p>	<p>SPS-A100D-HAWS</p>
		
<p>Pin 1 = supply voltage (+)                      Pin 2 = output                      Pin 3 = ground (-)                      Pin 4 = inverted output</p>	<p>Pin 1 = supply voltage (+)                      Pin 2 = output                      Pin 3 = ground (-)                      Pin 4 = inverted output</p>	<p>Red wire = supply voltage (+)                      Green wire = output                      Black wire = ground (-)                      Blue wire = inverted output</p>

# SMART Position Sensor

Figure 3. Sensor Output Performance Chart Showing Ideal Outputs (Applies to all catalog listings.)

