



SPECIFICATION FOR LCD MODULE

MODULE NO: TF-LCM17723A-N-S0

Doc.Version:01

Customer Approval:

Accept

Reject

TOPFOISON	NAME	SIGNATURE	DATE
Prepare	Electronic Engineer	Zha peng fei 查鹏飞	2018-06-04
Check	Mechanical Engineer	Kuang hao xian 邝浩贤	2018-06-04
Verify		Liu xiao qiang 刘晓强	2018-06-04
Approval		Liu zhi sheng 刘智声	2018-06-04

APPROVAL FOR SPECIFICATIONS ONLY

APPROVAL FOR SPECIFICATIONS AND SAMPLE

TF-SFLRD01-A0



2. Table of Contents:

NO	CONTENTS	PAGE
1	Revision History	1
2	Table of Contents	2
3	Module Numbering System	3
4	General Specification	4
5	LCM drawing	5
6	Electrical Characteristics	6
7	Optical Characteristics	10
8	Interface Pin Assignment	12
9	Block Diagram	13
10	Backlight	14
11	Standard Specification for Reliability	15
12	Specification of Quality Assurance	17
13	Handling Precaution	25
14	Guarantee	25
15	Package	26



3. Module Numbering System:

(Example)

T F - L C M 3 9 7 0 6 A - N - V 0
① ② ③ ④ ⑤ ⑥ ⑦

①: TOPFOISON

②: LCD Module

③: LCD SIZE

④: Serial version:00~99, When it goes beyond a hundred bits, it can be raised as: 000~999, and so on

⑤: Customer Version: A~Z。

⑥: T: With Resistive Touch panel

C: With Capacitive Touch panel

N: Without Touch panel

⑦: S: STD Product

V: Customer Made

Sample Version: 0~9,When it goes beyond ten bits, it can be raised as:

00~99, and so on.



4. General Specification:

ITEM	CONTENTS
Module Size	33.8 (W) * 45.83(H) * 2.75(T) mm
Module Size(With FPC)	33.8(W) * 145.75 (H) * 2.75 (T) mm
Display Size(Diagonal)	1.77 inch
Display Format	128(RGB)*160Pixels
Active Area	28.03(W) * 35.04(H) mm
Pixel Pitch	0.219*0.219 mm
LCD Type	Transmissive / Normally White
View Direction	12 O' Clock
Controller IC	ST7735S
Weight	TBD



5. LCM drawing:

Rev.	Revision content description	Date
#1	FIRST ISSUE	2018-04-14
#2	更改FPC长度,更改FPC出Pin定义	2018-05-18
#3	更改FPC出Pin顺序	2018-06-04

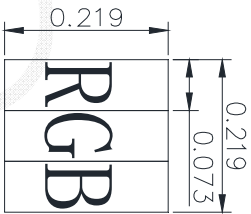
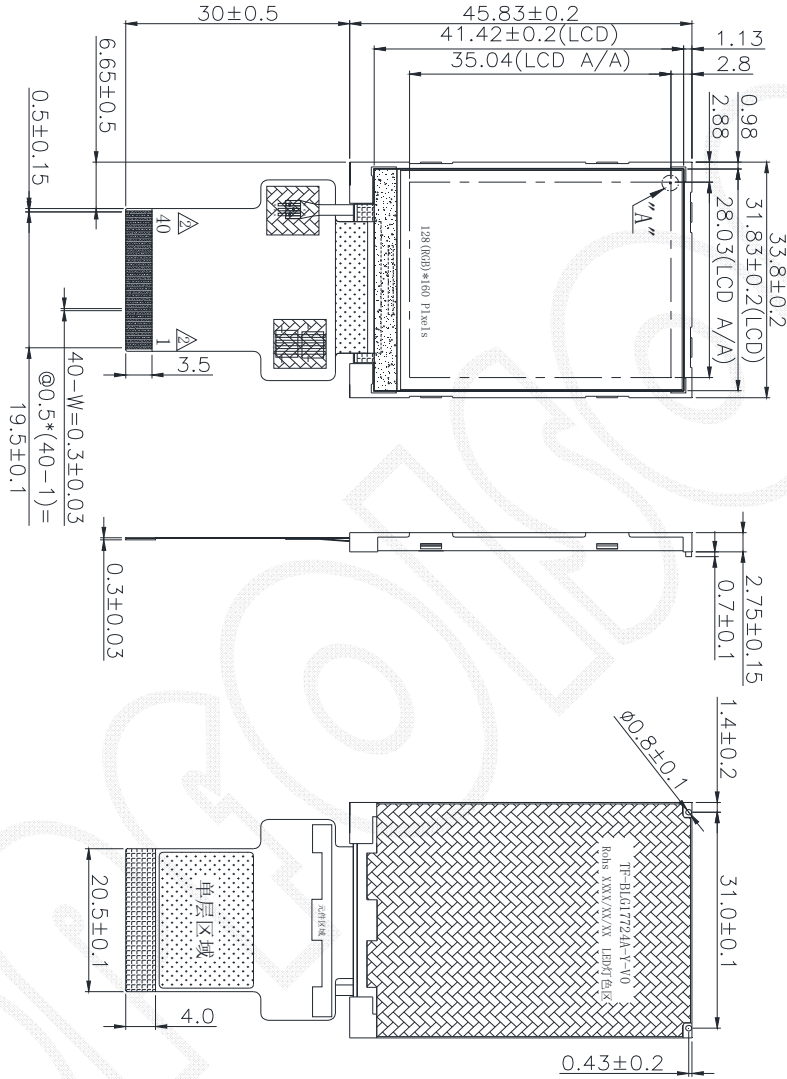

Scale: 100X

- Specification:**
1. Display mode: 1.77" TFT / Normal White/ Transmissive
 2. Drive condition: VDD=3.3V
 3. Viewing direction: Gray Inversion direction: 12 O'clock
The Best Viewing Direction: 6 O'clock
 4. Operating temperature: -30°C to +80°C
 5. Drive IC is: S17738S
 6. Backlight: 2 CHIP WHITE LED
 7. Unspecified tolerance: ±0.30mm.
 8. ROHS compliant

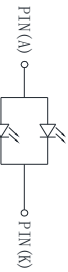

LED CIRCUIT DIAGRAM:
If I=40mA Voltage=3.2V

深圳市拓丰源电子科技有限公司 TOPFOISON INDUSTRY Co., LIMITED		MOD. Name	TF-LCM17723A-N-S0	DESIGNED	丁浩贤	2018-06-04	CHECKED	VERIFIED	APPROVED	FILE NAME	Outline
UNIT	mm	SIZE	A4	SCALE	N-T-S					Sheet	1
										Or	1

No.	Symbol
1	IM2
2	IM1
3	IM0
4	RESET
5	NC
6	CS
7	RS/SCL
8	WR/D
9	RDX
10	SDI/SDA
11	NC
12	DB0
13	DB1
14	DB2
15	DB3
16	DB4
17	DB5
18	DB6
19	DB7
20	DB8
21	DB9
22	DB10
23	DB11
24	DB12
25	DB13
26	DB14
27	DB15
28	GND
29	GND
30	GND
31	IOVCC
32	VCC
33	LED-A
34	LEDK
35	LEDK
36	LED-PWM
37	XR
38	YD
39	XL
40	YU



6. Electrical Characteristics

6-1 Absolute Maximum Ratings

(Ta=25°C VSS=0V)

Item	Symbol	Min.	Type	Max.	Unit	Remark
Supply Voltage	V _{CI}	-0.3	-	+4.8	V	Note1
Supply Voltage(Logic)	IOV _{CC}	-0.3		+4.6		Note1
Logic Input Voltage Range	V _{IN}	0.3		IOV _{CC} +0.3	V	Note1
Operating Temperature	Topr	-20	-	+70	°C	-
Storage Temperature	Tstg	-30	-	+80	°C	-

Note1: Absolute maximum rating is the limit value beyond which the IC maybe broken.
They do not assure operations.

6-2 Operating Conditions

(Ta=25°C)

Item	Symbol	Condition	Min.	Typ.	Max.	Unit
Power Supply voltage	V _{DD}	-	2.5	2.8	4.8	Volt
Supply voltage for I/O	IOV _{CC}	-	1.65	1.8	3.7	Volt
Input Voltage	V _{IH}	-	0.7 IOV _{CC}	-	IOV _{CC}	V
	V _{IL}	-	VSS	-	0.3 IOV _{CC}	V
Power Supply Current for LCM	I _{CC}	VCC=2.8V	-	TBD	-	mA

6-3 Timing Characteristics

8.1 Parallel Interface Characteristics: 18, 16, 9 or 8-bit Bus (8080 Series MCU Interface)

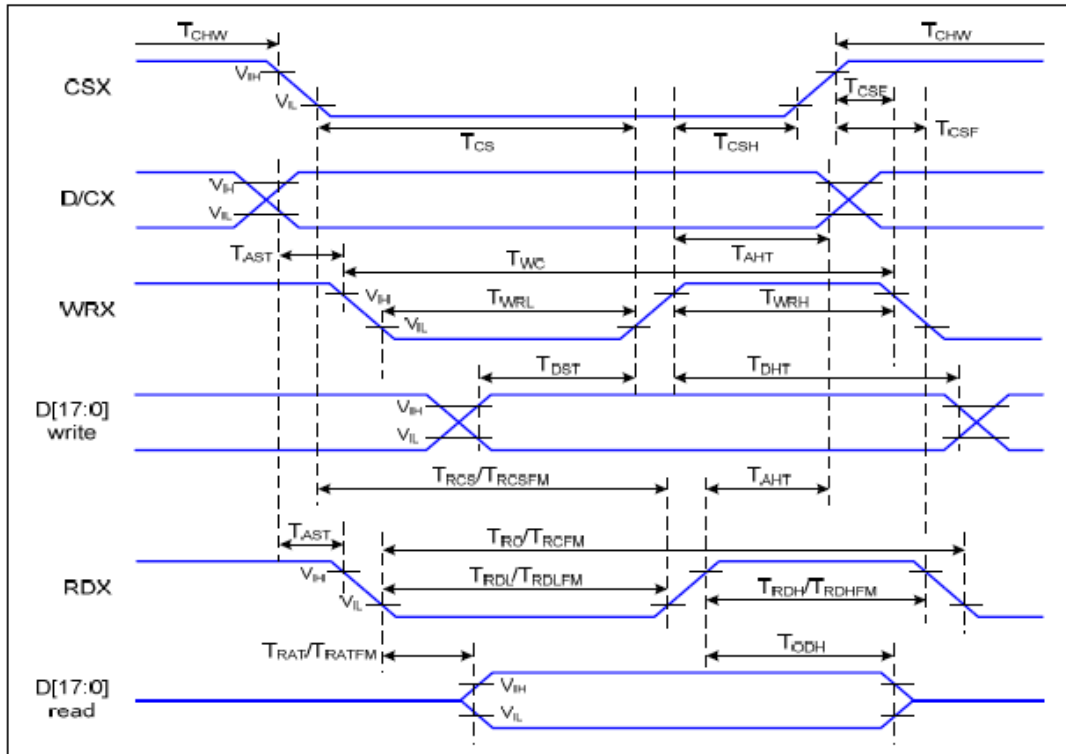

Figure 1 Parallel Interface Timing Characteristics (8080 Series MCU Interface)



Ta=25 °C, VDDI=1.65~3.7V, VDD=2.5~4.8V

Signal	Symbol	Parameter	Min	Max	Unit	Description
D/CX	TAST	Address Setup Ttime	0		ns	-
	TAHT	Address Hold Time (Write/Read)	10		ns	
CSX	TCHW	Chip Select "H" Pulse Width	0		ns	-
	TCS	Chip Select Setup Time (Write)	15		ns	
	TRCS	Chip Select Setup Time (Read ID)	45		ns	
	TRCSFM	Chip Select Setup time (Read FM)	355		ns	
	TCSF	Chip Select Wait Time (Write/Read)	10		ns	
	TCSH	Chip Select Hold Time	10		ns	
WRX	TWC	Write Cycle	66		ns	
	TWRH	Control Pulse "H" Duration	15		ns	
	TWRL	Control Pulse "L" Duration	15		ns	
RDX (ID)	TRC	Read Cycle (ID)	160		ns	When Read ID Data
	TRDH	Control Pulse "H" Duration (ID)	90		ns	
	TRDL	Control Pulse "L" Duration (ID)	45		ns	
RDX (FM)	TRCFM	Read Cycle (FM)	450		ns	When Read from Frame Memory
	TRDHFM	Control Pulse "H" Duration (FM)	90		ns	
	TRDLFM	Control Pulse "L" Duration (FM)	355		ns	
D[17:0]	TDST	Data Setup Time	10		ns	For CL=30pF
	TDHT	Data Hold Time	10		ns	
	TRAT	Read Access Time (ID)		40	ns	
	TRATFM	Read Access Time (FM)		340	ns	
	TODH	Output Disable Time	20	80	ns	

Table 4 8080 Parallel Interface Characteristics

8.4 Serial Interface Characteristics (4-line Serial)

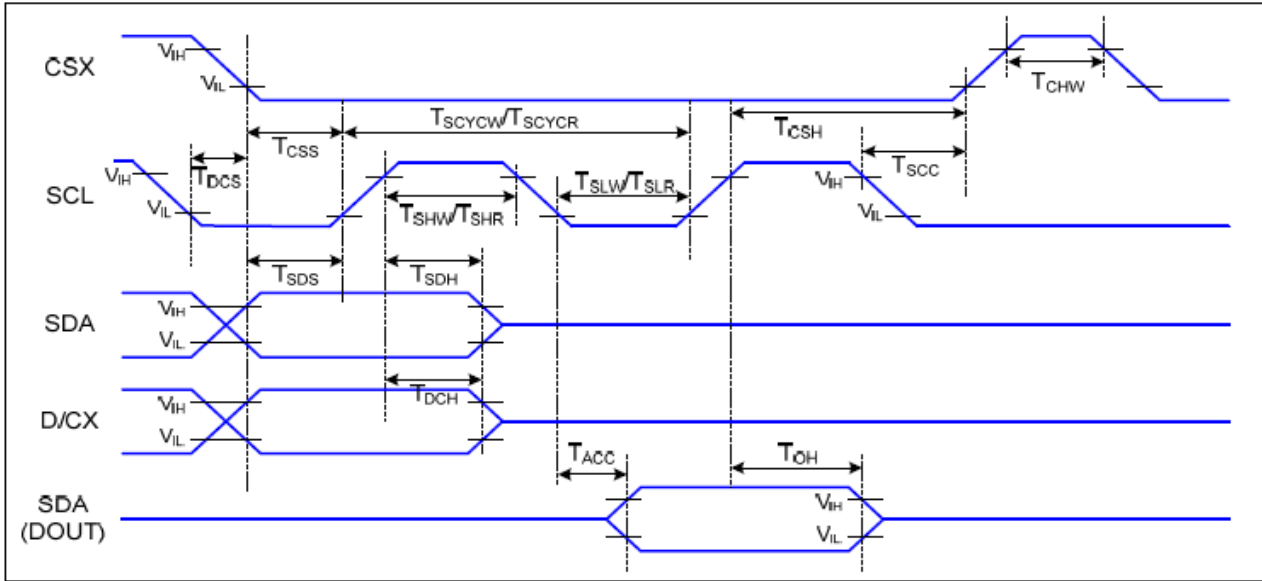

Figure 7 4-line Serial Interface Timing

Ta=25 °C, VDDI=1.65~3.7V, VDD=2.5~4.8V

Signal	Symbol	Parameter	MIN	MAX	Unit	Description
CSX	TCSS	Chip Select Setup Time (Write)	45		ns	
	TCSH	Chip Select Hold Time (Write)	45		ns	
	TCSS	Chip Select Setup Time (Read)	60		ns	
	TSCC	Chip Select Hold Time (Read)	65		ns	
	TCHW	Chip Select "H" Pulse Width	40		ns	
SCL	TSCYCW	Serial Clock Cycle (Write)	66		ns	-Write Command & Data Ram
	TSHW	SCL "H" Pulse Width (Write)	15		ns	
	TSLW	SCL "L" Pulse Width (Write)	15		ns	
	TSCYCR	Serial Clock Cycle (Read)	150		ns	-Read Command & Data Ram
	TSHR	SCL "H" Pulse Width (Read)	60		ns	
	TSLR	SCL "L" Pulse Width (Read)	60		ns	
D/CX	TDCS	D/CX Setup Time	10		ns	
	TDCH	D/CX Hold Time	10		ns	
SDA (DIN) (DOUT)	TSDS	Data Setup Time	10		ns	For Maximum CL=30pF For Minimum CL=8pF
	TSDH	Data Hold Time	10		ns	
	TACC	Access Time	10	50	ns	
	TOH	Output Disable Time	15	50	ns	

Table 7 4-line Serial Interface Characteristics



7. Optical Characteristics:

Item	Symbol	Conditions	Specifications			Unit	Note	
			Min	Typ	Max			
Transmittance (Without PL)	T (%)	-	-	19.1	-	-	-	
Contrast Ratio	CR	$\Theta=0$ Normal Viewing angle	-	500	-		(1) (2)	
Response time	TR+TF	-	-	8	16	ms	(1) (3)	
Viewing angle	Hor	Θ_{x+}	CR ≥ 10	-	45	-	deg.	-
		Θ_{x-}		-	45	-		
	Ver	Θ_{y+}		-	45	-		
		Θ_{y-}		-	20	-		

Measuring Condition

1. Measuring surrounding: dark room
2. Ambient temperature: $25 \pm 2^\circ\text{C}$
3. 30 min. Warm-up time.

Color of CIE Coordinate:

Item	Symbol	Condition	Min.	Typ.	Max.	
Chromaticity Coordinates (Transmissive)	Red	x	TBD	0.626	TBD	
		y	TBD	0.334	TBD	
	Green	x	$\theta = \phi = 0^\circ$ LED Backlight Color Degree	TBD	0.277	TBD
		y		TBD	0.549	TBD
	Blue	x		TBD	0.142	TBD
		y		TBD	0.122	TBD
	White	x		TBD	0.303	TBD
		y		TBD	0.325	TBD

Note (1) Definition of Viewing Angle:

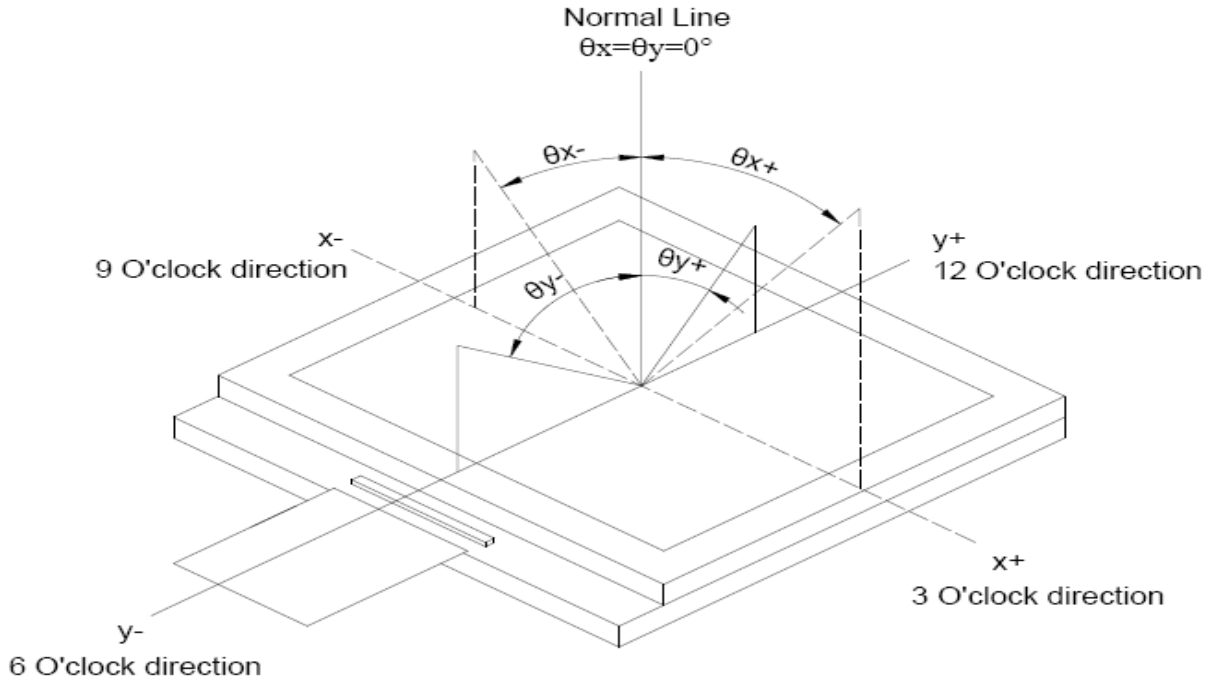

Note (2) Definition of Contrast Ratio (CR):
measured at the center point of panel

$$\text{Contrast ratio (CR)} = \frac{\text{Photo detector output when LCD is at "White" state}}{\text{Photo detector output when LCD is at "Black" state}}$$

Note (3) Definition of Response Time: Sum of TR and TF

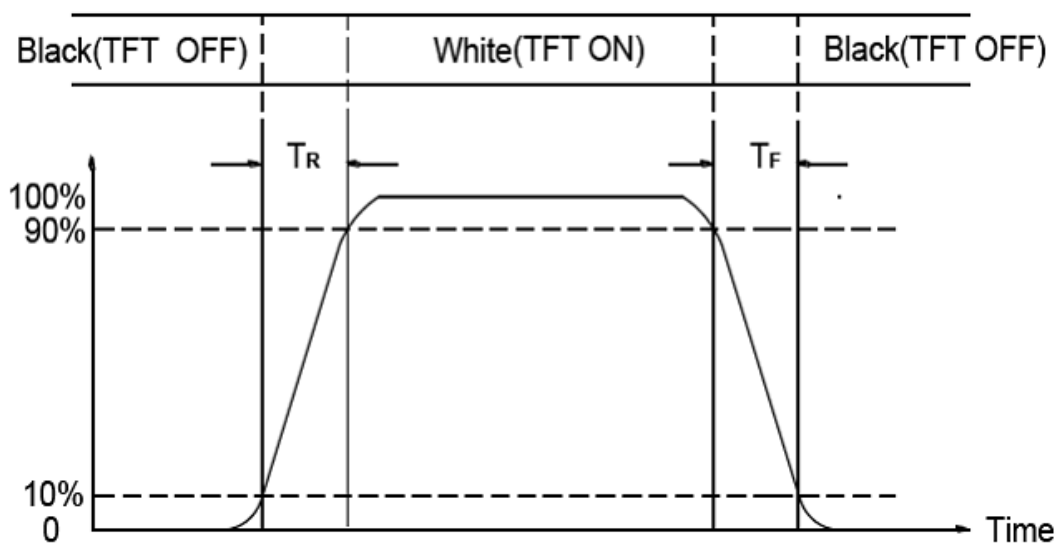



8. Interface Pin Assignment:

No.	Symbol	Function
1	IM2	MCU Parallel Interface Bus and Serial Interface select
2	IM1	MCU Parallel Interface Type Selection
3	IM0	MCU Parallel Interface Type Selection
4	RESET	This signal will reset the device and it must be applied to properly
5	NC	NO Connection
6	CS	Chip Selection Pin
7	RS/SCL	Display data/command Selection Pin in MCU Interface
8	WR/D	Write Enable in MCU Parallel Interface
9	RDX	Read Enable in 8080 MCU Parallel Interface
10	SDI/SDA	Tearing effect output pin to synchronies MCU to frame rate, activated
11	NC	NO Connection
12	DB0	Data bus
13	DB1	
14	DB2	
15	DB3	
16	DB4	
17	DB5	
18	DB6	
19	DB7	
20	DB8	
21	DB9	
22	DB10	
23	DB11	
24	DB12	
25	DB13	
26	DB14	
27	DB15	
28	GND	Ground
29	GND	Ground
30	GND	Ground
31	IOVCC	VDDI Voltage Output Level for Monitoring
32	VCC	Monitoring Pin of Internal Digital Reference Voltage
33	LED-A	Cathode of LED Backlight
34	LED-K	Anode of LED Backlight
35	LED-K	Anode of LED Backlight
36	LED-PWM	For LED Deng PWM regulation
37	XR	RTP-XR
38	YD	RTP-YD
39	XL	RTP-XL
40	YU	RTP-YU



9. Block Diagram:

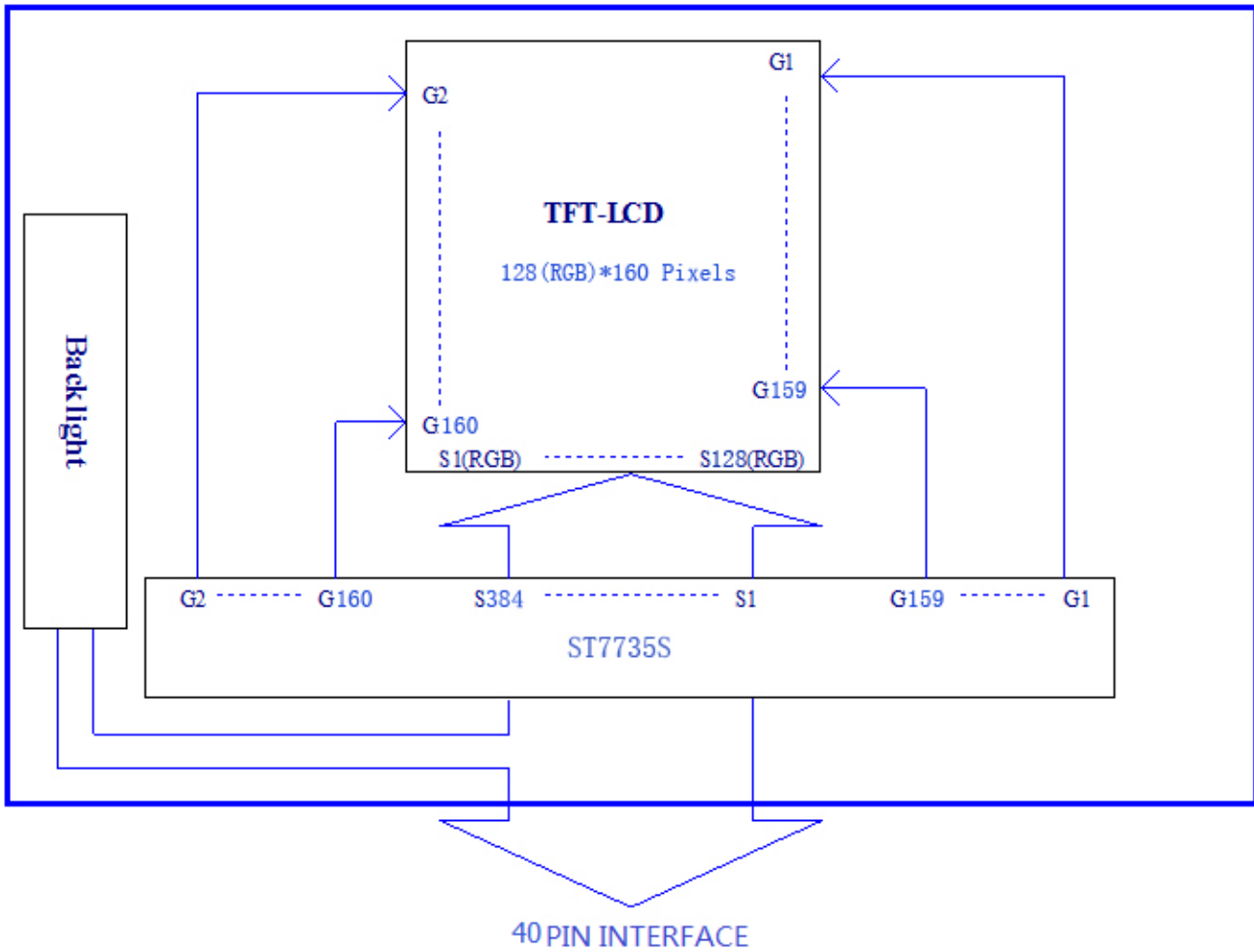

10. Backlight:

1. Standard Lamp Styles (Edge Lighting Type):

The LED chips are distributed over the edge light area of the illumination unit, which gives the less power consumption:

2. The Main Advantages of the LED Backlight are as following:

2.1 The brightness of the backlight can simply be adjusted.

By a resistor or a potentiometer.

3. Data About LED Backlight:

(Ta=25°C)

PARAMETER	Sym.	Min.	Typ.	Max.	Unit	Test Condition	Note
Supply Current	I	-	40	-	mA	V=3.2V	
Supply Voltage	V	2.6	3.2	3.5	V	If=40mA	
Luminous Intensity for LCM	IV	150	200	-	Cd/m ²		2
Uniformity for LCM	-	70	-	-	%		3
Life Time	-	20000	-	-	Hr.		4
Color	White						

NOTE:

1. Backlight Only

2. Average Luminous Intensity of P1-P9

3. Uniformity = Min/Max * 100%

4. LED life time defined as follows: The final brightness is at 50% of original brightness

Measured Method: (X*Y: Light Area)

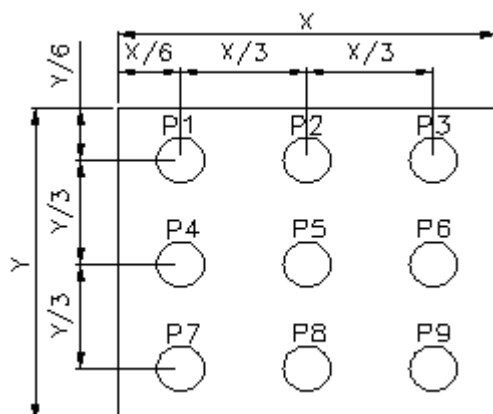

Internal Circuit Diagram

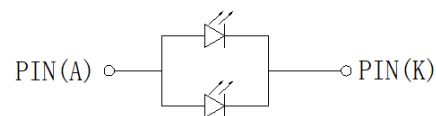

LED CIRCUIT DIAGRAM:

(Effective spatial Distribution)

Using aperture of 1°, distance 50cm.



11. Standard Specification for Reliability:

11-1. Standard Specifications for Reliability of LCD Module

No	Item	Description
01	High temperature operation (高温通电)	The sample should be allowed to stand at 70°C for 48 hours under driving condition and then returning it to normal temperature condition, and allowing it stand for 2 hours.
02	Low temperature operation (低温通电)	The sample should be allowed to stand at -20°C for 48hours under driving condition and then returning it to normal temperature condition, and allowing it stand for 2 hours.
03	High temperature storage (高温存储)	The sample should be allowed to stand at 80°C for 48 hours under no-load condition, and then returning it to normal temperature condition and allowing it stand for 2 hours.
04	Low temperature storage (低温存储)	The sample should be allowed to stand at -30°C for 48 hours under no-load condition, then returning it to normal temperature condition, and allowing it stand for 2 hours.
05	Moisture storage (高温高湿)	The sample should be allowed to stand at 60°C, 90%RH MAX for 48 hours under no-load condition, then taking it out and drying it at normal temperature for 2 hours.
06	Thermal shock storage (冷热冲击)	The sample should be allowed to stand the following 10 cycles : -30°C for 30 minutes → normal temperature for 5 minutes → +80°C for 30 minutes → normal temperature for 5 minutes, as one cycle.
07	Packing vibration (包装震动)	Frequency range : 10Hz ~ 55Hz Amplitude of vibration : 1.5mm Sweep time: 12 min X, Y, Z 2 hours for each direction.
08	Packing drop test (跌落实验)	According to ISTA 1A 2001.
09	Electrical Static Discharge (静电实验)	Air: ±4KV 150pF/330Ω 5 times
		Contact: ±2KV 150pF/330Ω 5 time

*Sample size for each test item is 1~3pcs

Module P/N: TF-LCM17723A-N-S0

Doc.Version:01



11 - 2. Testing Conditions and Inspection Criteria

For the final test the testing sample must be stored at room temperature for 24 hours, after the tests listed in Table 11-1, Standard specifications for Reliability have been executed in order to ensure stability.

No	Item	Test Model	In section Criteria
01	Current Consumption	Refer To Specification	The current consumption should conform to the product specification.
02	Contrast	Refer To Specification	After the tests have been executed, the contrast must be larger than half of its initial value prior to the tests.
03	Appearance	Visual inspection	Defect free.

11- 3. MTBF

MTBF	Functions, performance, appearance, etc. shall be free from remarkable deterioration within 50,000 hours under ordinary operating and storage conditions room temperature ($25\pm 5^{\circ}\text{C}$), normal humidity ($50\pm 10\%$ RH), and in area not exposed to direct sun light.
------	---



12. Specification of Quality Assurance:

12-1. Purpose

This standard for Quality Assurance should affirm the quality of LCD module products to supply to purchaser by TOPFOISON INDUSTRY (Supplier).

12-2. Standard for Quality Test

a. Inspection:

Before delivering, the supplier should take the following tests, and affirm the quality of product.

b. Electro-Optical Characteristics:

According to the individual specification to test the product.

c. Test of Appearance Characteristics:

According to the individual specification to test the product.

d. Test of Reliability Characteristics:

According to the definition of reliability on the specification for testing products.

e. Delivery Test:

Before delivering, the supplier should take the delivery test.

(i) Test method: According to ISO2859-1. General Inspection Level II take a single time.

(ii) The defects classify of AQL as following:

Major defect: AQL = 0.65

Minor defect: AQL = 2.5

Total defects: AQL = 2.5

12-3. Non- conforming Analysis & Deal With Manners

a. Non- conforming Analysis:

(i) Purchaser should supply the detail data of non- conforming sample and the non- conforming.

(ii) After accepting the detail data from purchaser, the analysis of non- conforming should be finished in two weeks.

(iii) If supplier can not finish analysis on time, must announce purchaser before 3 days.

b. Disposition of non- conforming:

(i) If find any product defect of supplier during assembly time, supplier must change the good product for every defect after recognition.

(ii) Both supplier and customer should analyze the reason and discuss the disposition of non- conforming when the reason of nonconforming is not sure.

12-4. Agreement items

Both sides should discuss together when the following problems happen.

a. There is any problem of standard of quality assurance, and both sides should think that must be modified.

b. There is any argument item which does not record in the standard of quality assurance.

c. Any other special problem.

12-5. Standard of The Product Appearance Test

a. Manner of appearance test:

(i) The test must be under $20W \times 2$ or $40W$ fluorescent light, and the distance of view must be at $30 \pm 5\text{cm}$.

(ii) When test the model of transmissive product must add the reflective plate.

(iii) The test direction is base on around 10° of vertical line.

(iii) Temperature: $25 \pm 5^\circ\text{C}$ Humidity: $60 \pm 10\% \text{RH}$

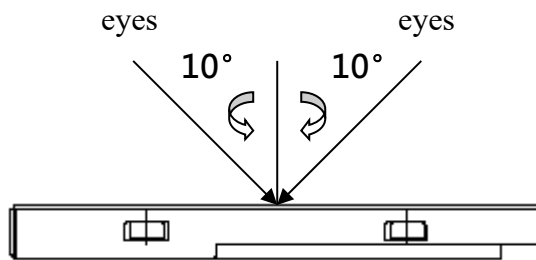

(iv) Definition of area:

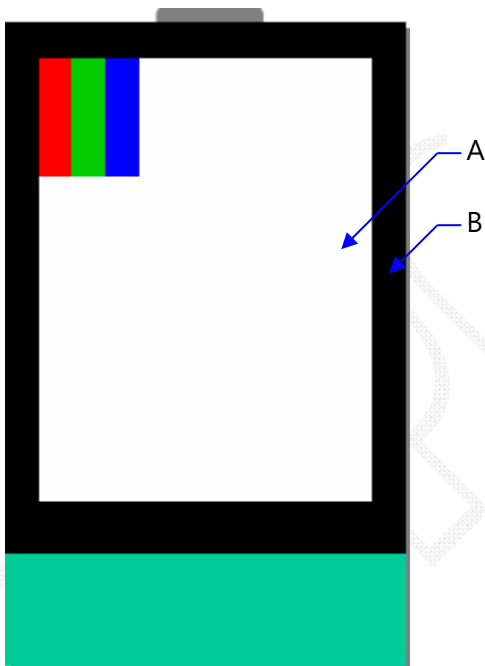

A. Area: Viewing area.

B. Area: Out of viewing area.

(Outside viewing area)

b. Basic principle:

(i) It will accord to the AQL when the standard can not be described.

(ii) The sample of the lowest acceptable quality level must be discussed by both supplier and customer when any dispute happened.

(iii) Must add new item on time when it is necessary.

c. Standard of inspection: (Unit: mm)

12-6. Inspection specification

Defect out of viewing area can be neglected.

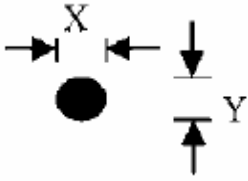
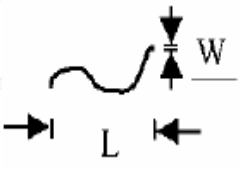
NO	Item	Criterion	AQL												
01	Electrical Testing	1.1 Missing vertical, horizontal segment, segment contrast defect. 1.2 Missing character, dot or icon. 1.3 Display malfunction. 1.4 No function or no display. 1.5 Current consumption exceeds product specifications. 1.6 LCD viewing angle defect. 1.7 Mixed product types. 1.8 Flicker	0.65												
02	Black or White spots or Bright spots or Color spots on LCD (Display only)	2.1 White and black or color spots on display $\leq 0.25\text{mm}$, no more than Five spots. 2.2 Densely spaced: No more than three spots within 3mm.	2.5												
03	LCD and Touch Panel black spots, white spots, contamination (non – display)	3.1 Round type: As following drawing $\Phi = (X+Y) / 2$  <table border="1" data-bbox="829 1097 1364 1400"> <thead> <tr> <th>Size(mm)</th> <th>Acceptable Q'ty</th> </tr> </thead> <tbody> <tr> <td>$\Phi \leq 0.10$</td> <td>Accept no dense</td> </tr> <tr> <td>$0.10 < \Phi \leq 0.20$</td> <td>3</td> </tr> <tr> <td>$0.20 < \Phi \leq 0.25$</td> <td>2</td> </tr> <tr> <td>$0.25 < \Phi \leq 0.30$</td> <td>1</td> </tr> <tr> <td>$0.30 < \Phi$</td> <td>0</td> </tr> </tbody> </table> <p>* Densely spaced: No more than two spots within 3mm.</p>	Size(mm)	Acceptable Q'ty	$\Phi \leq 0.10$	Accept no dense	$0.10 < \Phi \leq 0.20$	3	$0.20 < \Phi \leq 0.25$	2	$0.25 < \Phi \leq 0.30$	1	$0.30 < \Phi$	0	2.5
		Size(mm)	Acceptable Q'ty												
$\Phi \leq 0.10$	Accept no dense														
$0.10 < \Phi \leq 0.20$	3														
$0.20 < \Phi \leq 0.25$	2														
$0.25 < \Phi \leq 0.30$	1														
$0.30 < \Phi$	0														
3.2 Line type: (As following drawing)  <table border="1" data-bbox="694 1534 1364 1803"> <thead> <tr> <th>Length(mm)</th> <th>Width(mm)</th> <th>Acceptable Q'ty</th> </tr> </thead> <tbody> <tr> <td>---</td> <td>$W \leq 0.02$</td> <td>Accept no dense</td> </tr> <tr> <td>$L \leq 3.0$</td> <td>$0.02 < W \leq 0.05$</td> <td rowspan="2">2</td> </tr> <tr> <td>$L \leq 2.5$</td> <td>$0.03 < W \leq 0.15$</td> </tr> <tr> <td>---</td> <td>$0.15 < W$</td> <td>Rejection</td> </tr> </tbody> </table> <p>* Densely spaced: No more than two lines within 3mm.</p>	Length(mm)	Width(mm)	Acceptable Q'ty	---	$W \leq 0.02$	Accept no dense	$L \leq 3.0$	$0.02 < W \leq 0.05$	2	$L \leq 2.5$	$0.03 < W \leq 0.15$	---	$0.15 < W$	Rejection	2.5
Length(mm)	Width(mm)	Acceptable Q'ty													
---	$W \leq 0.02$	Accept no dense													
$L \leq 3.0$	$0.02 < W \leq 0.05$	2													
$L \leq 2.5$	$0.03 < W \leq 0.15$														
---	$0.15 < W$	Rejection													

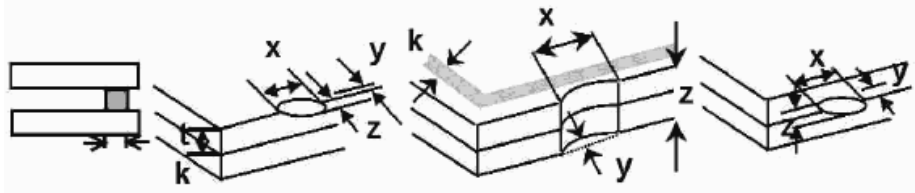
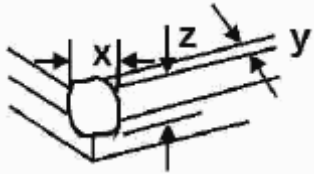

NO	Item	Criterion	AQL																		
04	Polarizer bubbles	<p>If bubbles are visible, judge using black spot specifications, not easy to find, must check in specify direction</p> <table border="1"> <thead> <tr> <th>Size Φ(mm)</th> <th>Acceptable Q'ty</th> </tr> </thead> <tbody> <tr> <td>$\Phi \leq 0.20$</td> <td>Accept no dense</td> </tr> <tr> <td>$0.20 < \Phi \leq 0.50$</td> <td>3</td> </tr> <tr> <td>$0.50 < \Phi \leq 1.00$</td> <td>2</td> </tr> <tr> <td>$1.00 < \Phi$</td> <td>0</td> </tr> <tr> <td>Total Q'ty</td> <td>3</td> </tr> </tbody> </table>	Size Φ (mm)	Acceptable Q'ty	$\Phi \leq 0.20$	Accept no dense	$0.20 < \Phi \leq 0.50$	3	$0.50 < \Phi \leq 1.00$	2	$1.00 < \Phi$	0	Total Q'ty	3	2.5						
Size Φ (mm)	Acceptable Q'ty																				
$\Phi \leq 0.20$	Accept no dense																				
$0.20 < \Phi \leq 0.50$	3																				
$0.50 < \Phi \leq 1.00$	2																				
$1.00 < \Phi$	0																				
Total Q'ty	3																				
05	Scratches	Follow NO.3 -2 Line Type.																			
06	Chipped glass	<p>Symbols: x: Chip length y: Chip width z: Chip thickness k: Seal width t: Glass thickness a: LCD side length L: Electrode pad length</p> <p>6.1 General glass chip: 6.1.1 Chip on panel surface and crack between panels:</p>  <table border="1"> <thead> <tr> <th>z: Chip thickness</th> <th>y: Chip width</th> <th>x: Chip length</th> </tr> </thead> <tbody> <tr> <td>$Z \leq 1/2t$</td> <td>Not over viewing area</td> <td>$x \leq 1/8a$</td> </tr> <tr> <td>$1/2t < z \leq 2t$</td> <td>Not exceed 1/3k</td> <td>$x \leq 1/8a$</td> </tr> </tbody> </table> <p>Unit: mm ⊙ If there are 2 or more chips, x is the total length of each chip</p> <p>6.1.2 Corner crack:</p>  <table border="1"> <thead> <tr> <th>z: Chip thickness</th> <th>y: Chip width</th> <th>x: Chip length</th> </tr> </thead> <tbody> <tr> <td>$Z \leq 1/2t$</td> <td>Not over viewing area</td> <td>$x \leq 1/8a$</td> </tr> <tr> <td>$1/2t < z \leq 2t$</td> <td>Not exceed 1/3k</td> <td>$x \leq 1/8a$</td> </tr> </tbody> </table> <p>Unit: mm ⊙ If there are 2 or more chips, x is the total length of each chip</p>	z: Chip thickness	y: Chip width	x: Chip length	$Z \leq 1/2t$	Not over viewing area	$x \leq 1/8a$	$1/2t < z \leq 2t$	Not exceed 1/3k	$x \leq 1/8a$	z: Chip thickness	y: Chip width	x: Chip length	$Z \leq 1/2t$	Not over viewing area	$x \leq 1/8a$	$1/2t < z \leq 2t$	Not exceed 1/3k	$x \leq 1/8a$	2.5
z: Chip thickness	y: Chip width	x: Chip length																			
$Z \leq 1/2t$	Not over viewing area	$x \leq 1/8a$																			
$1/2t < z \leq 2t$	Not exceed 1/3k	$x \leq 1/8a$																			
z: Chip thickness	y: Chip width	x: Chip length																			
$Z \leq 1/2t$	Not over viewing area	$x \leq 1/8a$																			
$1/2t < z \leq 2t$	Not exceed 1/3k	$x \leq 1/8a$																			

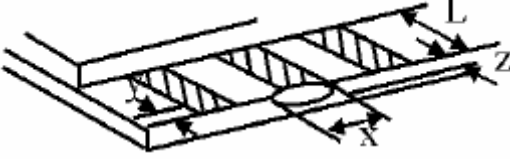
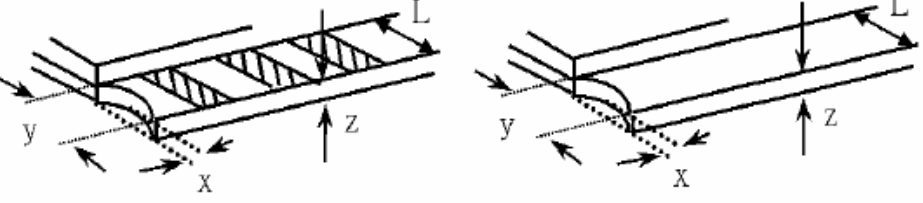
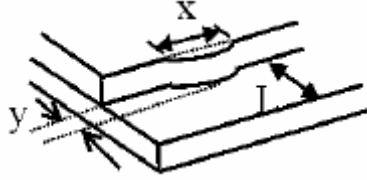
NO	Item	Criterion	AQL																
07	Glass crack	<p>Symbols: x: Chip length y: Chip width z: Chip thickness k: Seal width t: Glass thickness a: LCD side length L: Electrode pad length</p> <p>7.2 Protrusion over terminal: 7.2.1 Chip on electrode pad:</p>  <table border="1" data-bbox="550 772 1220 907"> <tr> <td>y: Chip width</td> <td>x: Chip length</td> <td>z: Chip thickness</td> </tr> <tr> <td>$y \leq 0.5\text{mm}$</td> <td>$x \leq 1/8a$</td> <td>$0 < z \leq t$</td> </tr> </table> <p>7.2.2 Non-conductive portion:</p>  <table border="1" data-bbox="550 1288 1220 1422"> <tr> <td>y: Chip width</td> <td>x: Chip length</td> <td>z: Chip thickness</td> </tr> <tr> <td>$y \leq L$</td> <td>$x \leq 1/8a$</td> <td>$0 < z \leq t$</td> </tr> </table> <p>⊙ If there chipped area touches the ITO terminal, over 2/3 of the ITO must remain and be inspected according to electrode terminal specifications. ⊙ If the product will be heat sealed by the customer, the alignment mark must not be damaged.</p> <p>7.2.3 Substrate protuberance and internal crack</p>  <table border="1" data-bbox="869 1780 1300 1915"> <tr> <td>y: width</td> <td>x: length</td> </tr> <tr> <td>$y \leq 1/3L$</td> <td>$X \leq a$</td> </tr> </table>	y: Chip width	x: Chip length	z: Chip thickness	$y \leq 0.5\text{mm}$	$x \leq 1/8a$	$0 < z \leq t$	y: Chip width	x: Chip length	z: Chip thickness	$y \leq L$	$x \leq 1/8a$	$0 < z \leq t$	y: width	x: length	$y \leq 1/3L$	$X \leq a$	2.5
y: Chip width	x: Chip length	z: Chip thickness																	
$y \leq 0.5\text{mm}$	$x \leq 1/8a$	$0 < z \leq t$																	
y: Chip width	x: Chip length	z: Chip thickness																	
$y \leq L$	$x \leq 1/8a$	$0 < z \leq t$																	
y: width	x: length																		
$y \leq 1/3L$	$X \leq a$																		

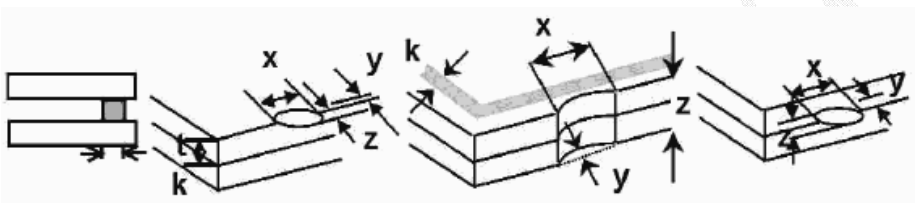
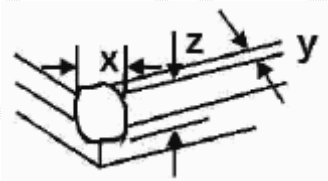

NO	Item	Criterion	AQL
08	Cracked glass	The LCD with extensive crack is not acceptable.	2.5
09	Backlight elements	9.1 Illumination source flickers when lit. 9.2 Spots or scratches that appear when lit must be judged. Using LCD spot, lines and contamination standards. 9.3 Backlight doesn't light or color is wrong.	2.5 2.5 0.65
10	Bezel	Bezel must comply with product specifications.	2.5
11	PCB、COB	11.1 COB seal may not have pinholes larger than 0.2mm or contamination. 11.2 COB seal surface may not have pinholes through to the IC. 11.3 The height of the COB should not exceed the height indicated in the assembly diagram. 11.4 There may not be more than 2mm of sealant outside the seal area on PCB. And there should be no more than three places. 11.5 Parts on PCB must be the same as on the production characteristic chart, There should be no wrong parts, missing parts or excess parts. 11.6 The jumper on the PCB should conform to the product characteristic chart.	2.5 2.5 2.5 2.5 0.65 0.65
12	FPC	12.1 FPC terminal damage \leq 1/2 FPC terminal width and can not affect the function, we judge accept. 12.2 FPC alignment hole damage \leq 1/2 alignment area and can not affect the function, we judge accept.	2.5 2.5
13	Soldering	13.1 No cold solder joints, missing solder connections, oxidation or icicle. 13.2 No short circuits in components on PCB or FPC.	2.5 0.65

NO	Item	Criterion	AQL												
14	Touch Panel Chipped glass	<p>Symbols: x: Chip length y: Chip width z: Chip thickness k: Seal width t: Touch Panel Total thickness a: LCD side length L: Electrode pad length</p> <p>14.1 General glass chip: 14.1.1 Chip on panel surface and crack between panels:</p>  <table border="1" data-bbox="414 884 1236 1097"> <tr> <td style="text-align: center;">z: Chip thickness</td> <td style="text-align: center;">y: Chip width</td> <td style="text-align: center;">x: Chip length</td> </tr> <tr> <td style="text-align: center;">$Z \leq t$</td> <td style="text-align: center;">$\leq 1/2 k$ and not over viewing area</td> <td style="text-align: center;">$x \leq 1/8a$</td> </tr> </table> <p>⊙ Unit: mm ⊙ If there are 2 or more chips, x is the total length of each chip</p> <p>14.1.2 Corner crack:</p>  <table border="1" data-bbox="414 1512 1236 1724"> <tr> <td style="text-align: center;">z: Chip thickness</td> <td style="text-align: center;">y: Chip width</td> <td style="text-align: center;">x: Chip length</td> </tr> <tr> <td style="text-align: center;">$z \leq t$</td> <td style="text-align: center;">$\leq 1/2 k$ and not over viewing area</td> <td style="text-align: center;">$x \leq 1/8a$</td> </tr> </table> <p>⊙ Unit: mm ⊙ If there are 2 or more chips, x is the total length of each chip</p>	z: Chip thickness	y: Chip width	x: Chip length	$Z \leq t$	$\leq 1/2 k$ and not over viewing area	$x \leq 1/8a$	z: Chip thickness	y: Chip width	x: Chip length	$z \leq t$	$\leq 1/2 k$ and not over viewing area	$x \leq 1/8a$	2.5
z: Chip thickness	y: Chip width	x: Chip length													
$Z \leq t$	$\leq 1/2 k$ and not over viewing area	$x \leq 1/8a$													
z: Chip thickness	y: Chip width	x: Chip length													
$z \leq t$	$\leq 1/2 k$ and not over viewing area	$x \leq 1/8a$													

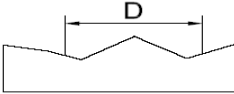
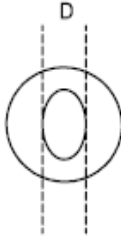

NO	Item	Criterion	AQL										
15	Touch Panel(Fish eye、dent and bubble on film)	<table border="1"> <thead> <tr> <th>SIZE(mm)</th> <th>Acceptable Q'ty</th> </tr> </thead> <tbody> <tr> <td>$\Phi \leq 0.2$</td> <td>Accept no dense</td> </tr> <tr> <td>$0.2 < D \leq 0.4$</td> <td>5</td> </tr> <tr> <td>$0.4 < D \leq 0.5$</td> <td>2</td> </tr> <tr> <td>$0.5 < D$</td> <td>0</td> </tr> </tbody> </table>	SIZE(mm)	Acceptable Q'ty	$\Phi \leq 0.2$	Accept no dense	$0.2 < D \leq 0.4$	5	$0.4 < D \leq 0.5$	2	$0.5 < D$	0	2.5
		SIZE(mm)	Acceptable Q'ty										
		$\Phi \leq 0.2$	Accept no dense										
		$0.2 < D \leq 0.4$	5										
		$0.4 < D \leq 0.5$	2										
$0.5 < D$	0												
													
													
16	Touch Panel Newton ring	Newton ring dimension $\leq 1/2$ touch panel area and not affect font and line distortion ($\leq 2.5\%$), it is acceptable.	2.5										
17	Touch Panel Linearity	Less than 2.5% is acceptable.	2.5										
18	LCD Ripple	Touch the touch panel, can not see the LCD ripple. Pen: R 1.0mm silicon rubber. Operation Force: 80g	2.5										
19	General appearance	19.1 Pin type must match type in specification sheet.	0.65										
		19.2 LCD pin loose or missing pins.	0.65										
		19.3 Product packaging must the same as specified on packaging specification sheet.	0.65										
		19.4 Product dimension and structure must conform to product specification sheet.	0.65										



13. Handling Precaution:

13-1 Handling of LCM

- Don't give external shock.
- Don't apply excessive force on the surface.
- Liquid in LCD is hazardous substance. Must not lick and swallow. when the liquid is attach to your hand, skin, cloth etc. Wash it out thoroughly and immediately.
- Don't operate it above the absolute maximum rating.
- Don't disassemble the LCM.
- The operators should be grounded whenever he/she comes into contact with the module. Never touch any of the conductive parts such as the LSI pads, the copper leads on the PCB and the interface terminals with any parts of the human body.
- The modules should be kept in antistatic bags or other containers resistant to static for storage.
- The module is coated with a film to protect the display surface. Be care when peeling off this protective film since static electricity may be generated.

13-2 Storage

- Store in an ambient temperature of $25\pm 10^{\circ}\text{C}$, and in a relative humidity of $50\pm 10\%\text{RH}$. Don't expose to sunlight or fluorescent light.
- Storage in a clean environment, free from dust, active gas, and solvent.
- Store in anti-static electricity container.
- Store without any physical load.

13-3 Soldering

- Use only soldering irons with proper grounding and no leakage.
- Iron: No higher than $280\pm 10^{\circ}\text{C}$ and less than 3 sec during Hand soldering.
- Rewiring: no more than 2 times.

14. Guarantee:

Our products meet requirements of the environment.

TOPFOISON ROHS requirement is based on European Union Directive 2011/65/EU (ROHS)

Requirements and Update.