

Description

The [SPX2431](#) is a 3-terminal adjustable shunt voltage regulator providing a highly accurate bandgap reference. The SPX2431 acts as an open-loop error amplifier with a 2.5V temperature compensation reference. The SPX2431's thermal stability, wide operating current (100mA) and temperature range (0°C to 105°C) makes it suitable for a variety of applications that require a low cost, high performance solution. SPX2431A tolerance of 0.5% is proven to be sufficient to overcome all of the other errors in the system to virtually eliminate the need for trimming in the power supply manufacturer's assembly lines and contribute a significant cost savings.

The output voltage may be adjusted to any value between V_{REF} and 20 volts with two external resistors. In the standard shunt configuration, the combination of a low temperature coefficient, sharp turn on characteristics, low output impedance, and programmable output voltage makes this precision reference an excellent error amplifier. The SPX2431 is available in a SOT-23-3 package.

FEATURES

- Trimmed bandgap to 0.5% and 1.0%
- Wide operating current 1mA to 100mA
- Extended temperature range: 0°C to 105°C
- Low temperature coefficient: 30 ppm/°C
- Offered in 3 Pin SOT-23 (M)
- Replacement for TL431, AS2431
- Low noise output

APPLICATIONS

- Battery operating equipment
- Adjustable supplies
- Switching power supplies
- Error amplifiers
- Single supply amplifier
- Monitors / VCRs / TVs
- Personal computers

Ordering Information - [Back Page](#)

Functional Block Diagram

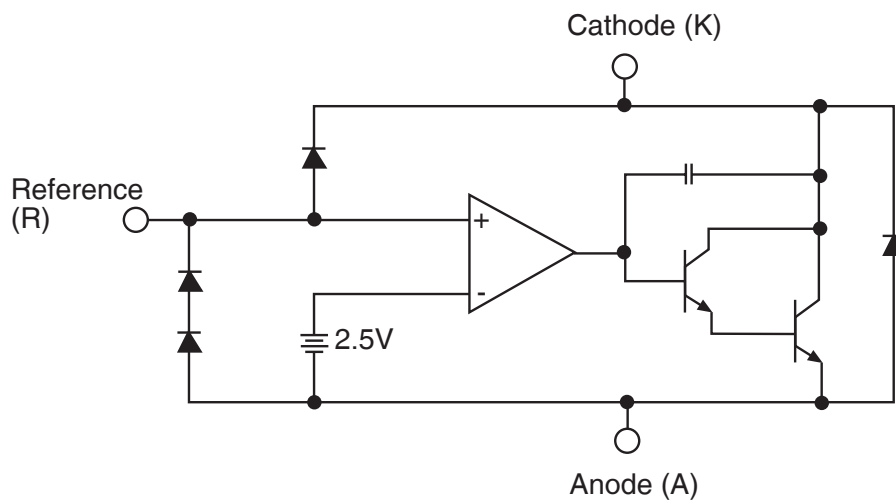

Absolute Maximum Ratings

NOTE: Stresses greater than those listed under ABSOLUTE MAXIMUM RATINGS may cause permanent damage to the device. This is a stress rating only and functional operation of the device at these or any other conditions above those indicated in the operational sections of this specification is not implied. Exposure to absolute maximum rating conditions for extended periods may affect reliability.

| | |
|--|----------------|
| Cathode-Anode Reverse Breakdown V_{KA} | 20V |
| Anode-Cathode Forward Current, (< 10ms) I_{AK} | 1A |
| Operating Cathode Current I_{KA} | 100mA |
| Reference Input Current I_{REF} | 1.0mA |
| Continuous Power Dissipation at 25°C P_D | |
| SOT-23..... | 200mW |
| Junction Temperature T_J | 150°C |
| Storage Temperature T_{STG} | -65°C to 150°C |

Recommended Conditions

| | |
|--------------------------------|------------------|
| Cathode Voltage V_{KA} | V_{REF} to 20V |
| Cathode Current I_K | 10mA |

Typical Thermal Resistances

| | |
|-----------------------|----------|
| SOT-23 | |
| Θ_{JA} | 575°C/W |
| Θ_{JC} | 150°C/W |
| Typical Derating..... | 1.7mW/°C |

Typical deratings of the thermal resistances are given for ambient temperature >25°C.

Electrical Characteristics

Electrical characteristics at 25°C, $I_K = 10mA$, $V_K = V_{REF}$, unless otherwise specified.

| PARAMETERS | SYMBOL | FIGURE | CONDITIONS | SPX2431A | | | SPX2431 | | | UNITS |
|---|-------------------------------------|--------|---|----------|-------|-------|---------|-------|-------|-------|
| | | | | MIN. | TYP. | MAX. | MIN. | TYP. | MAX. | |
| Reference voltage | V_{REF} | 2 | | 2.487 | 2.500 | 2.513 | 2.474 | 2.500 | 2.526 | V |
| | | 2 | $T_J = 0^\circ\text{C to } 105^\circ\text{C}$ | 2.480 | | 2.520 | 2.460 | | 2.540 | |
| ΔV_{REF} with temp. | TC | 2 | | | 0.07 | 0.20 | | 0.07 | 0.20 | mV/°C |
| Ratio of change in V_{REF} to cathode voltage | $\frac{\Delta V_{REF}}{\Delta V_K}$ | | V_{REF} to 10V | -2.7 | -1.01 | | -2.7 | -1.01 | | mV/V |
| | | 3 | 10V to 20V | -2.0 | -0.4 | 0.3 | -2.0 | -0.4 | 0.3 | |
| Reference input current | I_{REF} | 3 | | | 0.7 | 4.0 | | 0.7 | 4.0 | µA |
| I_{REF} temp deviation | ΔI_{REF} | 3 | $T_J = 0^\circ\text{C to } 105^\circ\text{C}$ | | 0.4 | 1.2 | | 0.4 | 1.2 | µA |
| Min I_K for regulation | $I_{K(MIN)}$ | 2 | | | 0.4 | 1.0 | | 0.4 | 1.0 | mA |
| Off state leakage | $I_{K(OFF)}$ | 4 | $V_{REF} = 0V,$ $V_{KA} = 20V$ | | 0.04 | | | 0.04 | 500 | nA |
| Dynamic output impedance | Z_{KA} | 2 | $f_z \leq 1kHz$ $I_K = 1$ to 100mA | | 0.15 | 0.5 | | 0.15 | 0.5 | Ω |

Pin Configuration

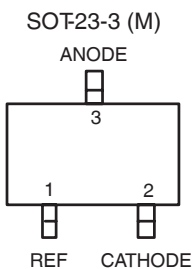

Top View

Calculating Average Temperature Coefficient (TC)

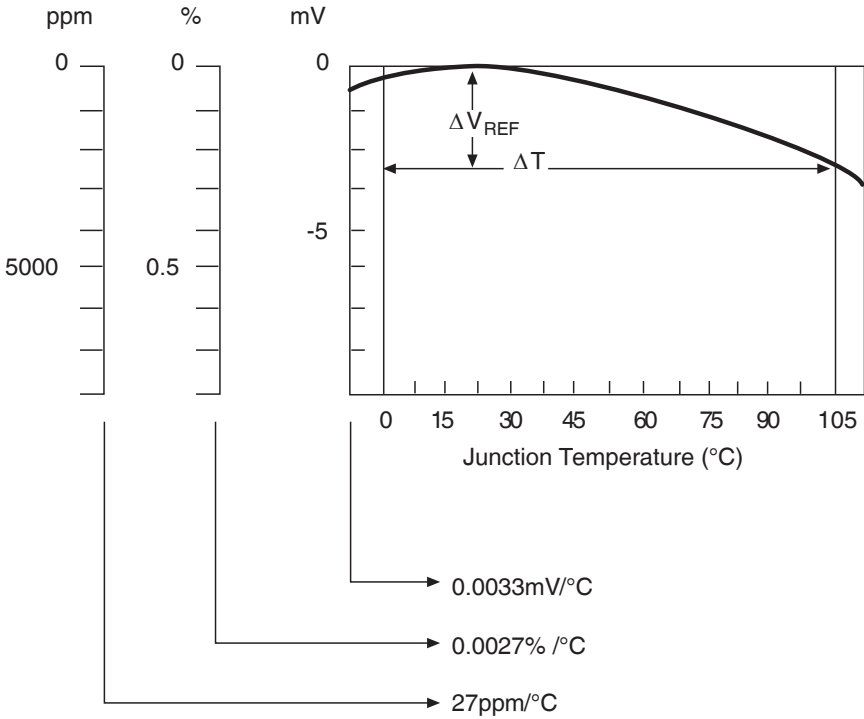

- TC in mV / °C = $\frac{\Delta V_{REF}(\text{mV})}{\Delta T_A}$
- TC in % / °C = $\frac{\left(\frac{\Delta V_{REF}}{\Delta V_{REF} \text{ at } 25^\circ\text{C}}\right) \times 100}{\Delta T_A}$
- TC in ppm / °C = $\frac{\left(\frac{\Delta V_{REF}}{\Delta V_{REF} \text{ at } 25^\circ\text{C}}\right) \times 10^6}{\Delta T_A}$

Figure 1: V_{REF} vs. Temperature

Test Circuits

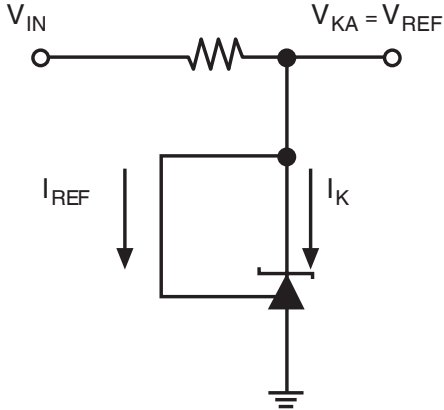

Figure 2: Test Circuit for $V_{KA} = V_{REF}$

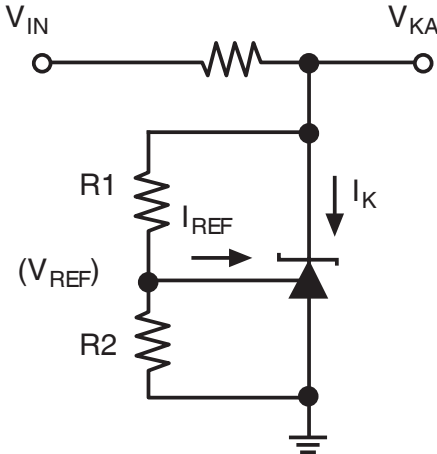

Figure 3: Test Circuit for $V_{KA} > V_{REF}$

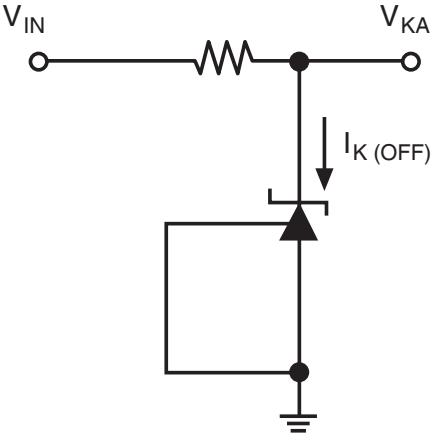

Figure 4: Test Circuit for $I_{K(OFF)}$

Typical Performance Characteristics

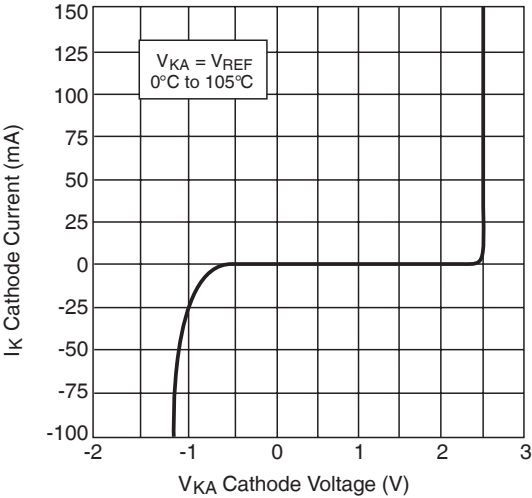

Figure 5: High Current Operating Characteristics

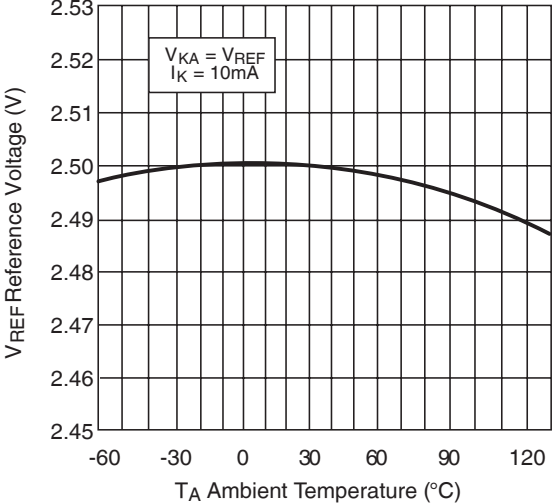

Figure 6: Reference Voltage vs. Ambient Temperature

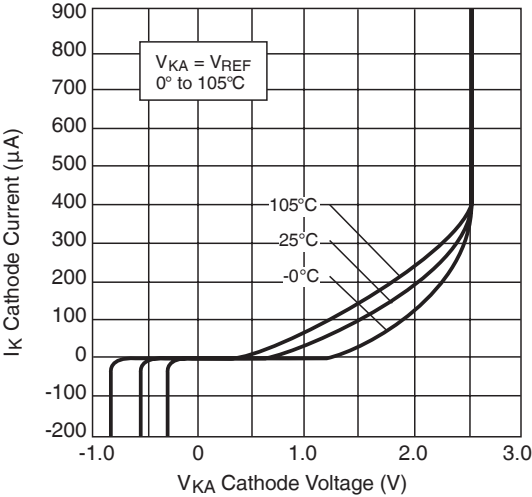

Figure 7: Low Current Operating Characteristics

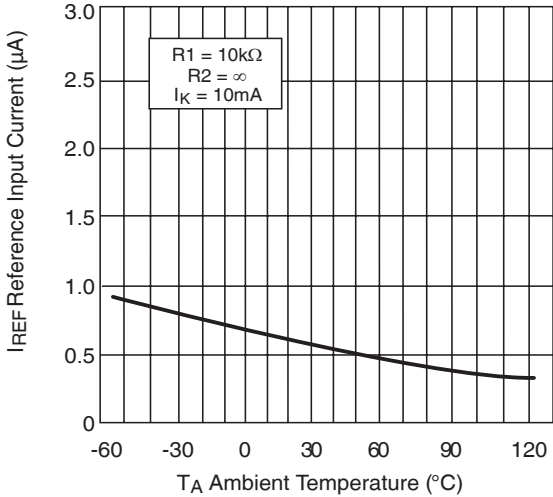

Figure 8: Reference Input Current vs. Ambient Temperature

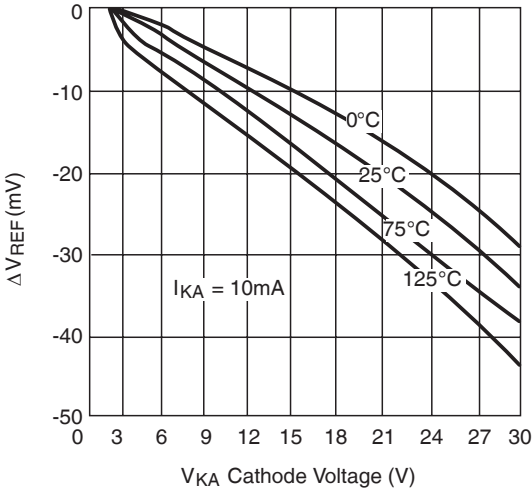

Figure 9: Reference Voltage Line Regulation vs. Cathode Voltage and T_{AMBIENT}

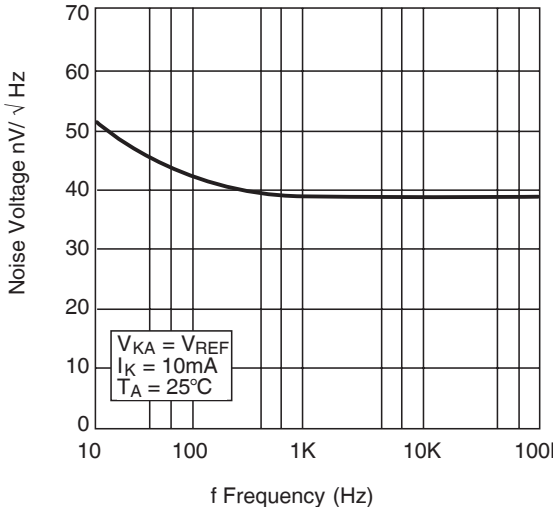

Figure 10: Noise Voltage vs. Frequency

Typical Performance Characteristics (continued)

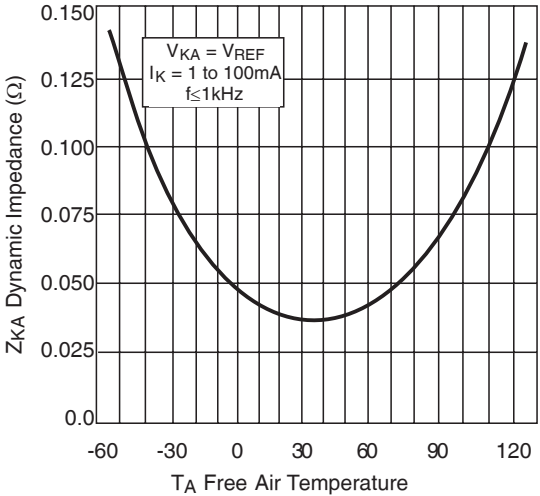

Figure 11: Low Frequency Dynamic Output Impedance vs. T_{AMBIENT}

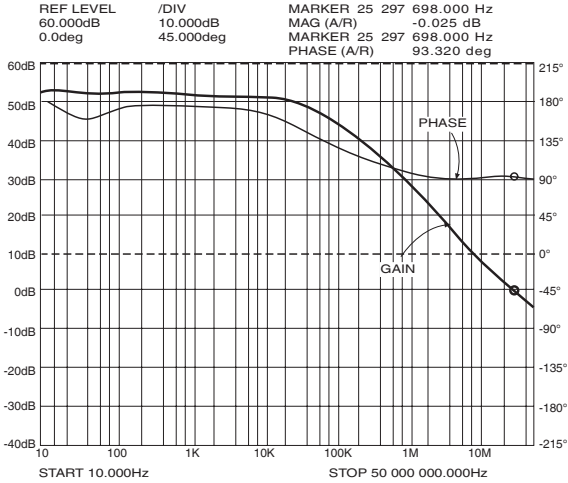

Figure 12. Small Signal Gain and Phase vs. Frequency; I_K = 10mA, T_A = 25°C

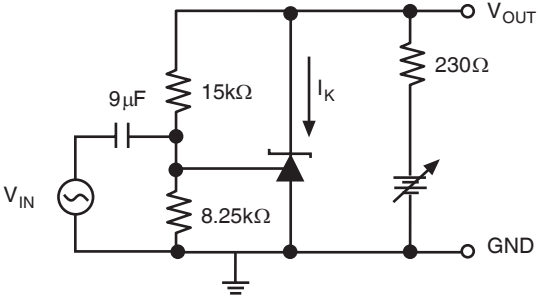

Figure 13. Test Circuit for Gain and Phase Frequency Response

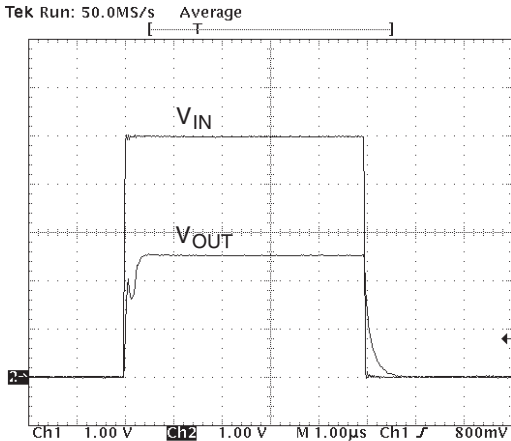

Figure 14. Frequency = 100kHz, I_K = 10mA, T_A = 25°C

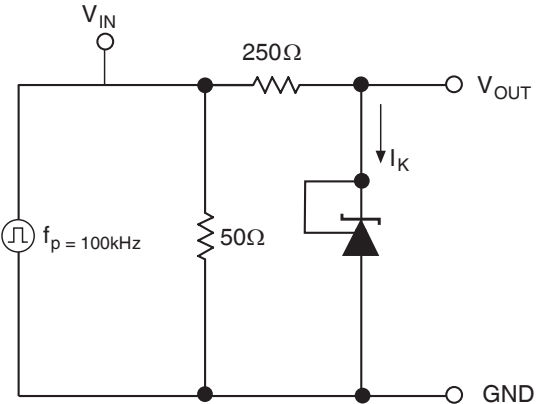

Figure 15. Test Circuit for Pulse Response

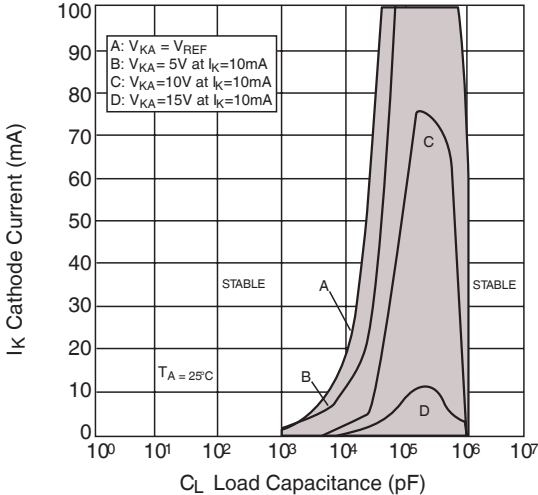

Figure 16. Stability Boundry Conditions

Typical Performance Characteristics (continued)

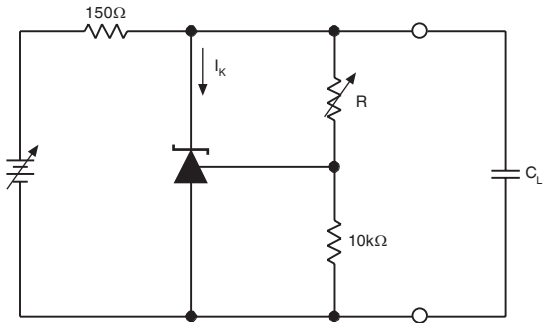

Figure 17: Test Circuit for Stability

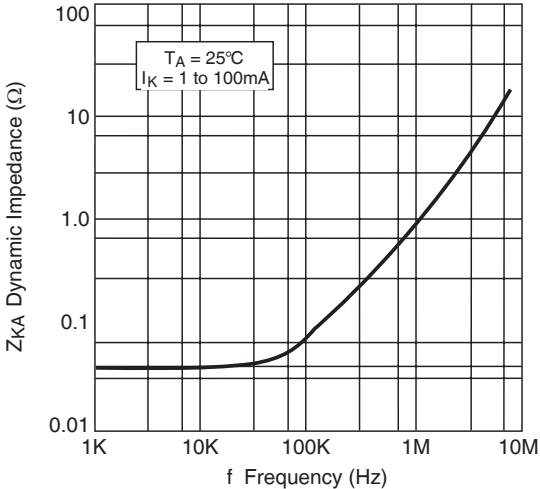

Figure 18: Dynamic Output Impedance $T_A = 25^\circ\text{C}$, $I_K = 1$ to 100mA

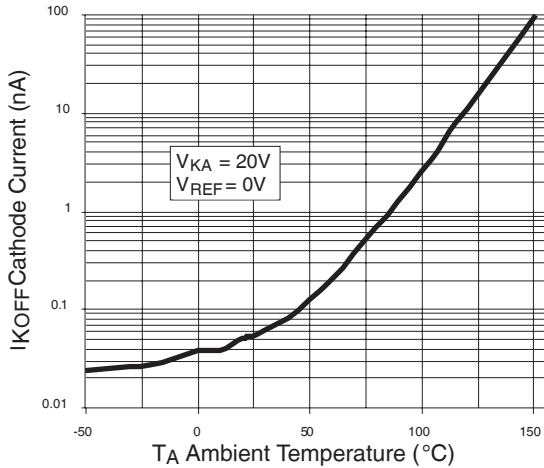

Figure 19: Off State Leakage

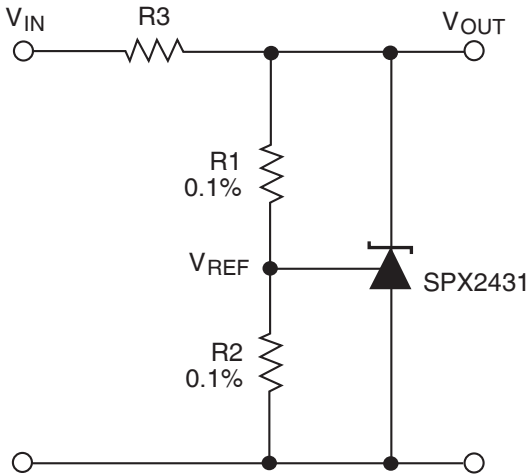

Figure 20: Shunt Regulator $V_{OUT} = (1+R1/R2)V_{REF}$

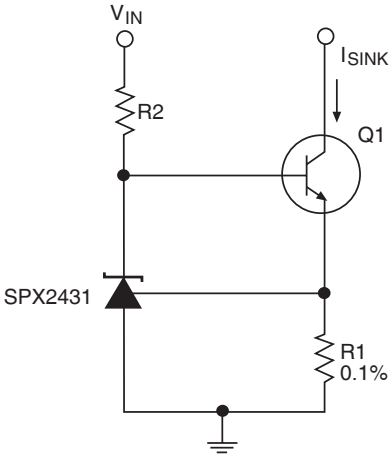

Figure 21: Constant Current, Sink, $I_{SINK} = V_{REF}/R1$

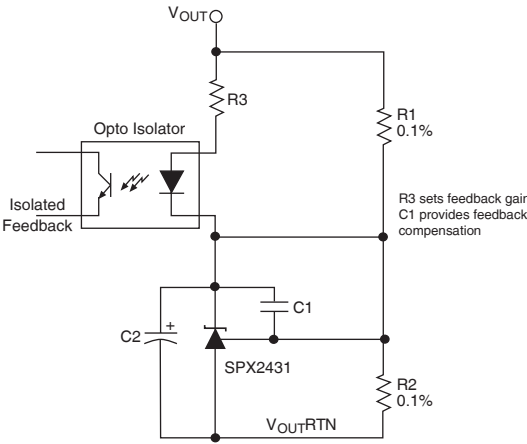

Figure 22: Reference Amplifier for Isolated Feedback in Off-Line DC-DC Converters

Typical Performance Characteristics (continued)

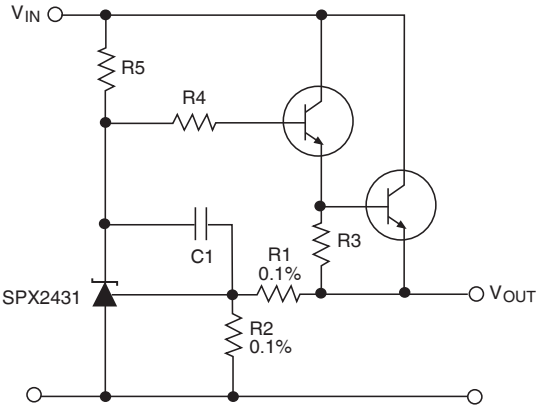

Figure 23: Precision High Current Series Regulator
 $V_{OUT} = (1+R1/R2)V_{REF}$

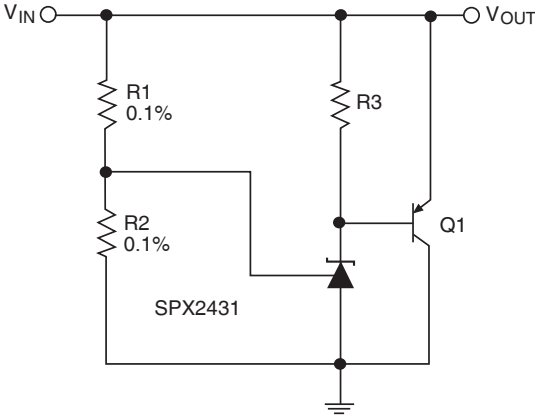
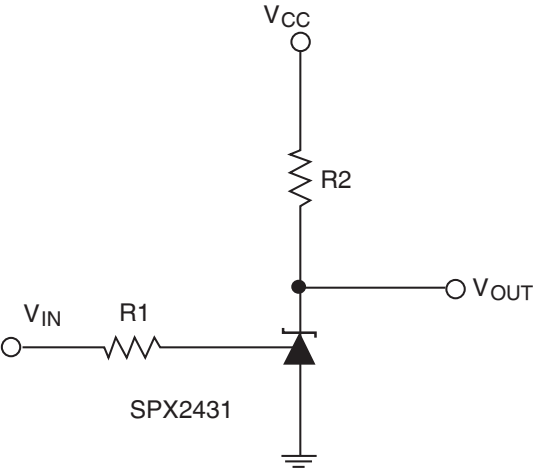

Figure 24: High Current Shunt Regulator
 $V_{OUT} = (1+R1/R2)V_{REF}$



* Resistor values are chosen such that the effect to I_{REF} is negligible.

Figure 25: Single Supply Comparator with Temperature Compensated Threshold. V_{IN} Threshold = 2.5V

Mechanical Dimensions

SOT-23-3

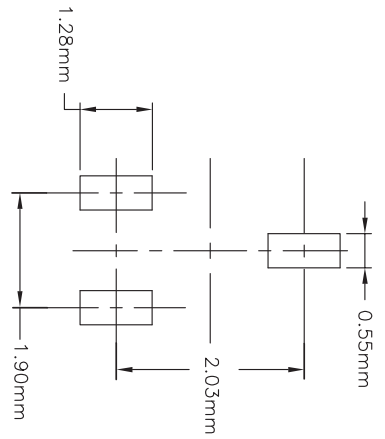
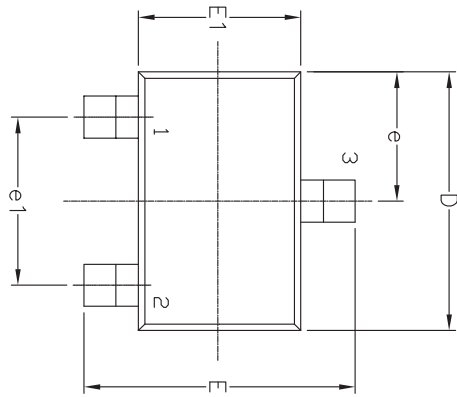
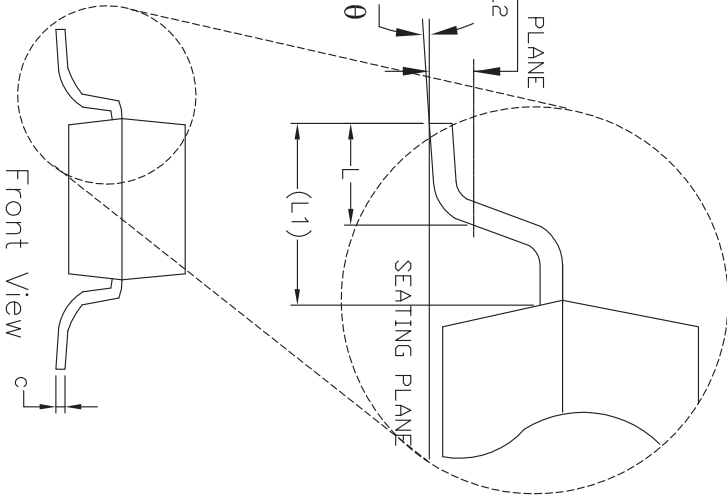
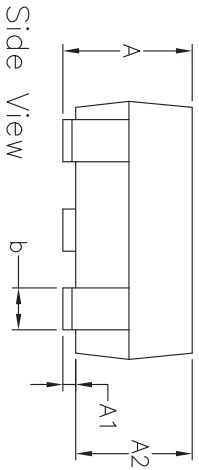

| SYMBOLS | DIMENSIONS IN MM (Control Unit) | | | DIMENSIONS IN INCH (Reference Unit) | | |
|---------|------------------------------------|------|-----------|--|-----------|-------|
| | MIN | NOM | MAX | MIN | NOM | MAX |
| A | 0.89 | — | 1.12 | 0.035 | — | 0.044 |
| A1 | 0.01 | — | 0.10 | 0.000 | — | 0.004 |
| A2 | 0.88 | 0.95 | 1.02 | 0.035 | 0.037 | 0.040 |
| b | 0.30 | — | 0.50 | 0.012 | — | 0.020 |
| c | 0.08 | — | 0.20 | 0.003 | — | 0.008 |
| D | 2.80 | 2.90 | 3.04 | 0.110 | 0.114 | 0.120 |
| E | 2.10 | — | 2.64 | 0.083 | — | 0.104 |
| E1 | 1.20 | 1.30 | 1.40 | 0.047 | 0.051 | 0.055 |
| e | 0.95 BSC | | 0.038 BSC | | 0.038 BSC | |
| e1 | 1.90 BSC | | 0.075 BSC | | 0.075 BSC | |
| L | 0.40 | 0.50 | 0.60 | 0.016 | 0.020 | 0.024 |
| L1 | 0.54 REF | | 0.021 REF | | 0.021 REF | |
| L2 | 0.25 BSC | | 0.010 BSC | | 0.010 BSC | |
| q | 0° | — | 8° | 0° | — | 8° |
| N | 3 | | | 3 | | |

Drawing No: PDD-00000031
Revision: A