

## 20A, 20V - 150V Schottky Barrier Surface Mount Rectifier

### FEATURES

- AEC-Q101 qualified
- Low power loss, high efficiency
- Ideal for automated placement
- Guard ring for overvoltage protection
- High surge current capability
- Moisture sensitivity level: level 1, per J-STD-020
- RoHS Compliant
- Halogen-free according to IEC 61249-2-21

### APPLICATIONS

- Low voltage, high freq. inverter
- DC/DC converter
- Freewheeling diodes
- Reverse battery protection
- Car lighting

### MECHANICAL DATA

- Case: TO-263AB (D<sup>2</sup>PAK)
- Molding compound meets UL 94V-0 flammability rating
- Terminal: Matte tin plated leads, solderable per J-STD-002
- Meet JESD 201 class 2 whisker test
- Polarity: As marked
- Weight: 1.70g (approximately)

KEY PARAMETERS		
PARAMETER	VALUE	UNIT
$I_F$	20	A
$V_{RRM}$	20 - 150	V
$I_{FSM}$	330	A
$T_{JMAX}$	150	°C
Package	TO-263AB (D <sup>2</sup> PAK)	
Configuration	Single die	

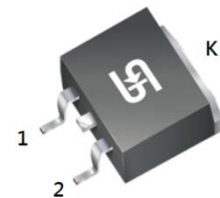
**TO-263AB (D<sup>2</sup>PAK)**

ABSOLUTE MAXIMUM RATINGS ( $T_A = 25^\circ\text{C}$ unless otherwise noted)										
PARAMETER	SYMBOL	SRAS	SRAS	SRAS	SRAS	SRAS	SRAS	SRAS	SRAS	UNIT
		2020	2030	2040	2050	2060	2090	20100	20150	
Marking code on the device		SRAS 2020	SRAS 2030	SRAS 2040	SRAS 2050	SRAS 2060	SRAS 2090	SRAS 20100	SRAS 20150	
Repetitive peak reverse voltage	$V_{RRM}$	20	30	40	50	60	90	100	150	V
Reverse voltage, total rms value	$V_{R(RMS)}$	14	21	28	35	42	63	70	105	V
Forward current	$I_F$	20								A
Surge peak forward current, 8.3ms single half sine wave superimposed on rated load	$I_{FSM}$	330								A
Junction temperature	$T_J$	-55 to +150								°C
Storage temperature	$T_{STG}$	-55 to +150								°C

<b>THERMAL PERFORMANCE</b>			
<b>PARAMETER</b>	<b>SYMBOL</b>	<b>TYP</b>	<b>UNIT</b>
Junction-to-case thermal resistance	$R_{\theta JC}$	1.5	°C/W

<b>ELECTRICAL SPECIFICATIONS</b> ( $T_A = 25^\circ\text{C}$ unless otherwise noted)						
<b>PARAMETER</b>		<b>CONDITIONS</b>	<b>SYMBOL</b>	<b>TYP</b>	<b>MAX</b>	<b>UNIT</b>
Forward voltage <sup>(1)</sup>	SRAS2020H SRAS2030H SRAS2040H	$I_F = 20\text{A}, T_J = 25^\circ\text{C}$	$V_F$	-	0.57	V
	SRAS2050H SRAS2060H			-	0.70	V
	SRAS2090H SRAS20100H			-	0.92	V
	SRAS20150H			-	1.02	V
Reverse current @ rated $V_R$ <sup>(2)</sup>	SRAS2020H SRAS2030H SRAS2040H SRAS2050H SRAS2060H	$T_J = 25^\circ\text{C}$	$I_R$	-	500	$\mu\text{A}$
	SRAS2090H SRAS20100H SRAS20150H			-	100	$\mu\text{A}$
	SRAS2020H SRAS2030H SRAS2040H	$T_J = 100^\circ\text{C}$		-	15	mA
	SRAS2050H SRAS2060H			-	10	mA
	SRAS2090H SRAS20100H SRAS20150H			-	-	mA
	SRAS2020H SRAS2030H SRAS2040H SRAS2050H SRAS2060H			$T_J = 125^\circ\text{C}$	-	-
	SRAS2090H SRAS20100H SRAS20150H	-			5	mA

**Notes:**

1. Pulse test with  $PW = 0.3\text{ms}$
2. Pulse test with  $PW = 30\text{ms}$

<b>ORDERING INFORMATION</b>		
<b>ORDERING CODE<sup>(1)</sup></b>	<b>PACKAGE</b>	<b>PACKING</b>
SRAS20xH	TO-263AB (D <sup>2</sup> PAK)	800 / Tape & Reel

**Notes:**

1. "x" defines voltage from 20V(SRAS2020H) to 150V(SRAS20150H)

**CHARACTERISTICS CURVES**

( $T_A = 25^\circ\text{C}$  unless otherwise noted)

**Fig.1 Forward Current Derating Curve**

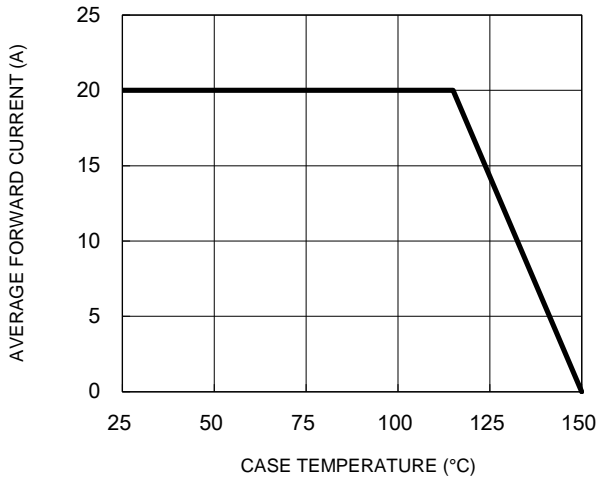

**Fig.2 Typical Junction Capacitance**

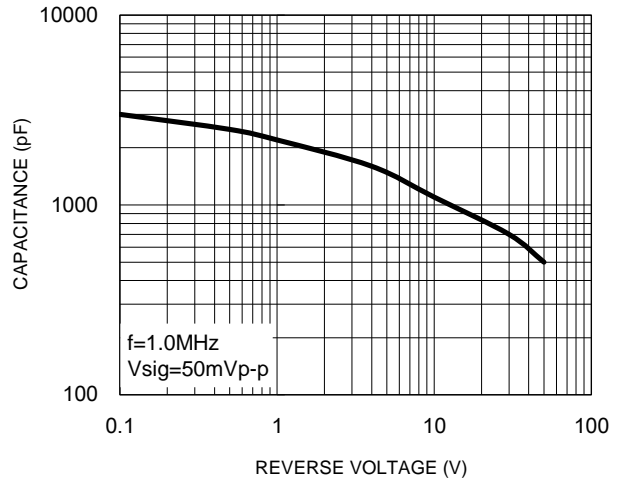

**Fig.3 Typical Reverse Characteristics**

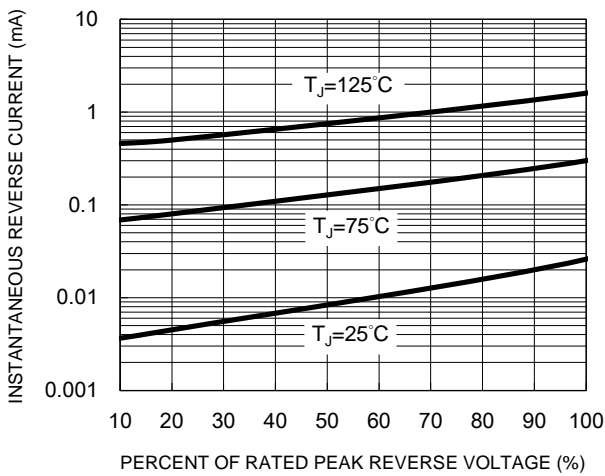

**Fig.4 Typical Forward Characteristics**

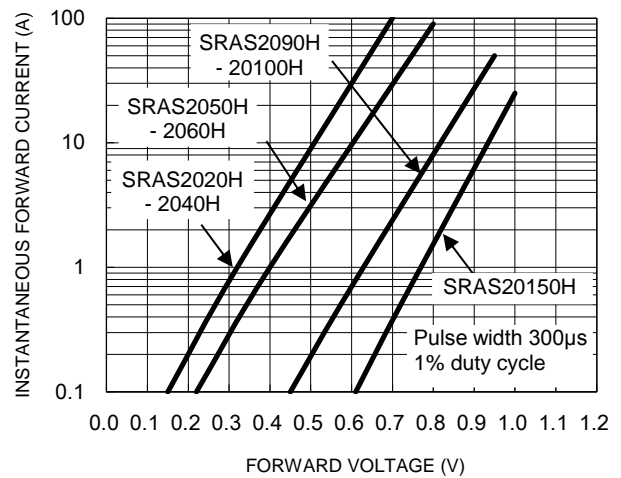

**Fig.5 Maximum Non-Repetitive Forward Surge Current**

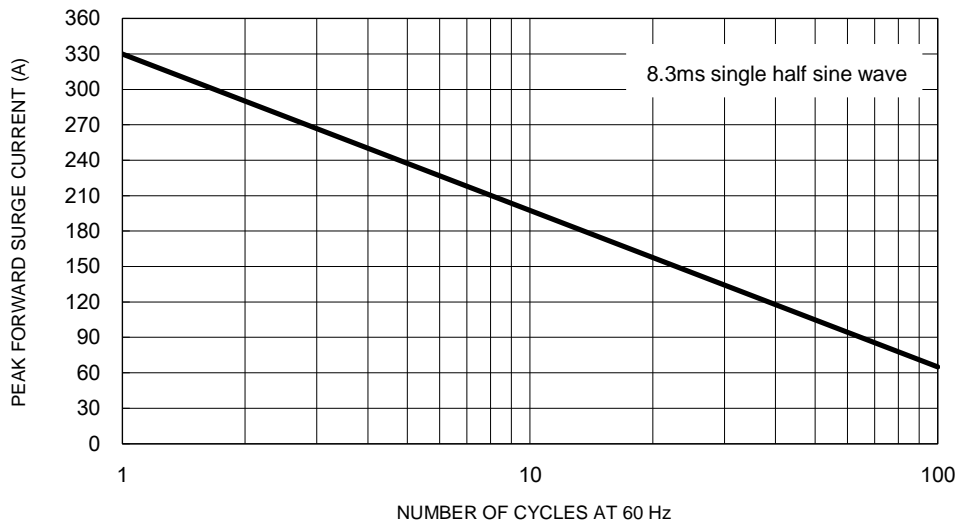

**CHARACTERISTICS CURVES**

( $T_A = 25^\circ\text{C}$  unless otherwise noted)

**Fig.6 Typical Transient Thermal Impedance**

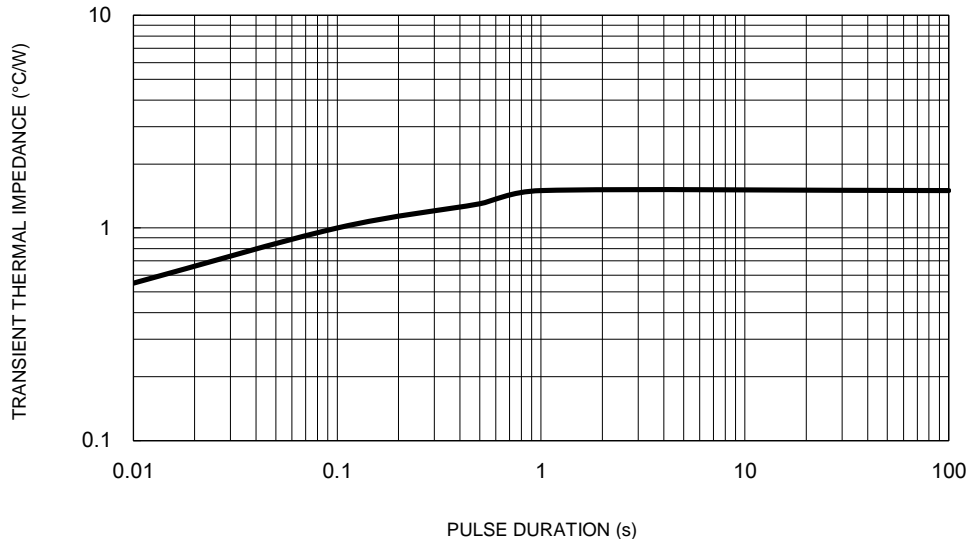

**PACKAGE OUTLINE DIMENSIONS**

TO-263AB (D<sup>2</sup>PAK)

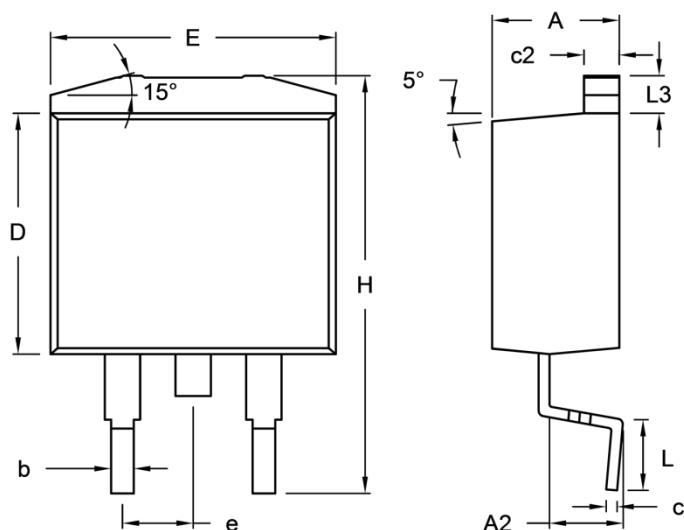

DIM.	Unit (mm)		Unit (inch)	
	Min.	Max.	Min.	Max.
A	4.44	4.70	0.175	0.185
A2	2.03	2.79	0.080	0.110
b	0.68	0.94	0.027	0.037
c	0.36	0.53	0.014	0.021
c2	1.14	1.40	0.045	0.055
D	8.25	9.25	0.325	0.364
E	-	10.50	-	0.413
e	2.41	2.67	0.095	0.105
H	14.60	15.88	0.575	0.625
L	2.29	2.79	0.090	0.110
L3	1.14	1.40	0.045	0.055

**SUGGESTED PAD LAYOUT**

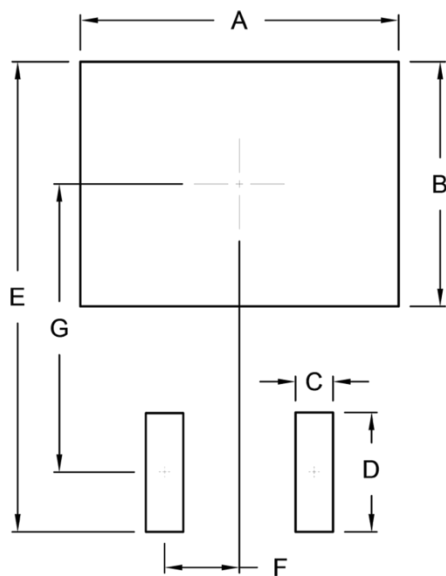

Symbol	Unit (mm)	Unit (inch)
A	10.80	0.425
B	8.30	0.327
C	1.27	0.050
D	4.05	0.159
E	15.95	0.628
F	2.54	0.100
G	9.775	0.385

**MARKING DIAGRAM**



- P/N = Marking Code
- G = Green Compound
- YWW = Date Code
- F = Factory Code