



SRM560VF

ULTRA LOW VF SCHOTTKY

VOLTAGE 60 Volt **CURRENT** 5 Ampere

FEATURES

- Plastic package has Underwriters Laboratory Flammability Classification 94V-O
- For surface mounted applications in order to optimize board space
- Ultra thin profile package for space constrained utilization
- Package suitable for automated handling
- Low power loss, high efficiency
- High surge capacity
- Lead free in compliance with EU RoHS 2.0
- Green molding compound as per IEC 61249 standard

MECHANICAL DATA

- Case: plastic molded
- Terminals: Solder plated, solderable per MIL-STD-750, Method 2026
- Approx. Weight: 0.0018 ounces, 0.05 grams
- Polarity: Color band denotes cathode end

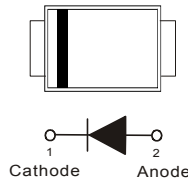

SMBF

Unit : inch(mm)

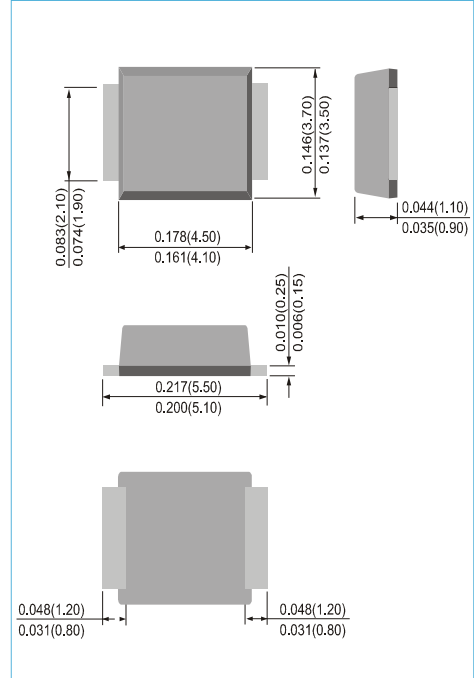

MAXIMUM RATINGS(T_A=25°C unless otherwise noted)

PARAMETER	SYMBOL	VALUE	UNIT
Maximum repetitive peak reverse voltage	V _{RRM}	60	V
Maximum rms voltage	V _{RMS}	42	V
Maximum dc blocking voltage	V _R	60	V
Maximum average forward rectified current	I _{F(AV)}	5	A
Peak forward surge current : 8.3ms single half sine-wave superimposed on rated load	I _{FSM}	120	A
Typical thermal resistance	R _{θJA} R _{θJL}	135 15	°C/W
Typical junction capacitance (V _R =4V, f=1MHz)	C _J	300	pF
Operating junction temperature range	T _J	-55 to + 150	°C
Storage temperature range	T _{STG}	-55 to + 150	°C

NOTES:1.Mounted on a FR4 PCB, single-sided copper, mini pad.
 2.Mounted on a FR4 PCB, single-sided copper, with 10cm*10cm copper pad area



SRM560VF

ELECTRICAL CHARACTERISTICS(T_A=25°C unless otherwise noted)

PARAMETER	SYMBOL	TEST CONDITIONS	MIN.	TYP.	MAX.	UNIT
Breakdown voltage	V _{BR}	I _R =0.5mA	60	-	-	V
Instantaneous forward voltage	V _F	I _F =1A	-	0.33	-	V
		I _F =3A	-	0.41	-	
		I _F =5A	-	0.47	0.52	
		T _J =25°C		-	-	-
		I _F =1A	-	0.25	-	V
		I _F =3A	-	0.37	-	
Reverse current	I _R	V _R =42V	-	20	-	μA
		V _R =60V	-	-	220	μA
		T _J =25°C	-	8.5	-	mA
		T _J =125°C	-	-	-	



SRM560VF

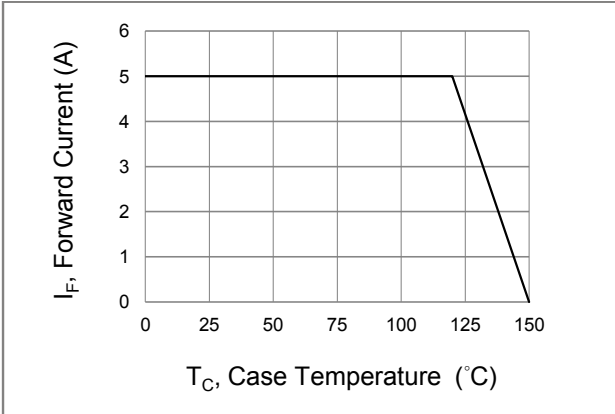

Fig.1 Forward Current Derating Curve

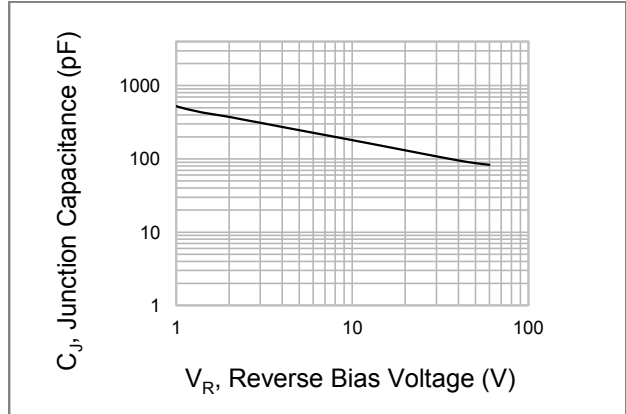

Fig.2 Typical Junction Capacitance

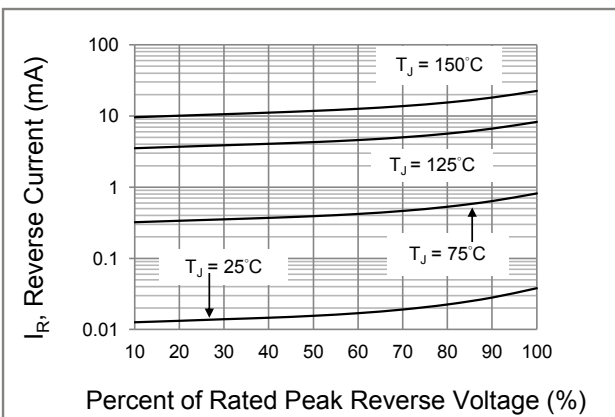

Fig.3 Typical Reverse Characteristics

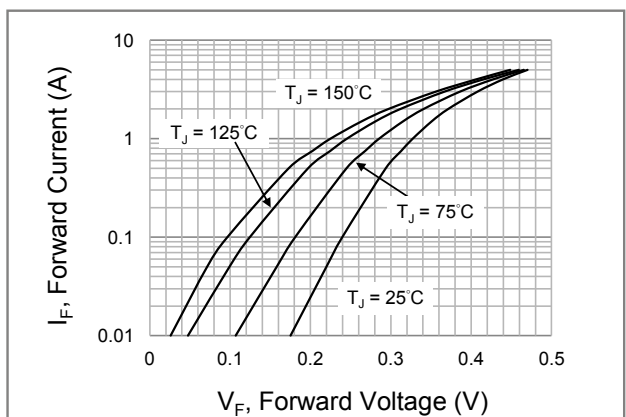

Fig.4 Typical Forward Characteristics

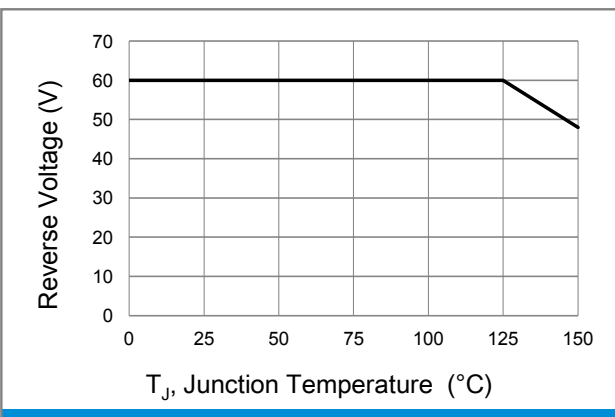
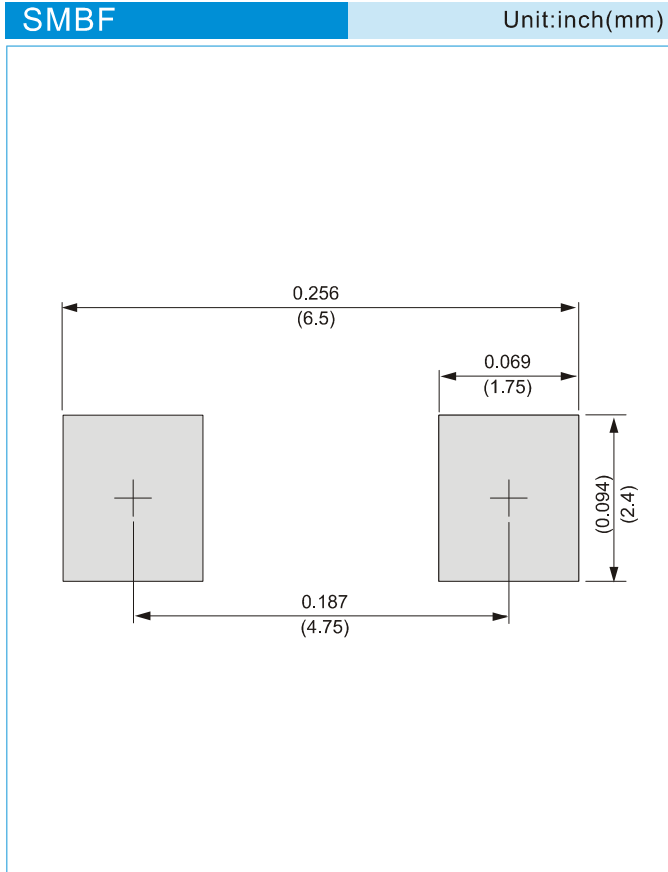

Fig.5 Operating Temperature Derating Curve



SRM560VF

MOUNTING PAD LAYOUT



ORDER INFORMATION

- Packing information
T/R - 5K per 13" plastic Reel



SRM560VF

Part No_packing code_Version

SRM560VF_R2_00001

For example :

RB500V-40_R2_00001



Packing Code XX				Version Code XXXXX		
Packing type	1 st Code	Packing size code	2 nd Code	HF or RoHS	1 st Code	2 nd ~5 th Code
Tape and Ammunition Box (T/B)	A	N/A	0	HF	0	serial number
Tape and Reel (T/R)	R	7"	1	RoHS	1	serial number
Bulk Packing (B/P)	B	13"	2			
Tube Packing (T/P)	T	26mm	X			
Tape and Reel (Right Oriented) (TRR)	S	52mm	Y			
Tape and Reel (Left Oriented) (TRL)	L	PANASERT T/B CATHODE UP (PBCU)	U			
FORMING	F	PANASERT T/B CATHODE DOWN (PBCD)	D			