



SSI SERIES AMPLIFIED STAINLESS STEEL PRESSURE SENSORS

The SSI pressure sensors perform precision digital signal conditioning and provide analogue and digital output at the same time. The sensors are calibrated, temperature compensated and linearized and achieve very high total accuracies. The stainless steel construction allows for high media compatibility with corrosive liquids and gases. Available packaging options include diaphragm versions with weld ring or housings with G 1/8 and 1/4 NPT threaded pressure ports. All SSI pressure sensors can be modified according to customer specific requirements.

Features

- 200 mbar to 35 bar, 3 to 500 Psi absolute, gage or vacuum pressure (custom pressure ranges on request)
- Amplified analog output and I²C bus interface (SPI on request)
- Precision ASIC signal conditioning
- Calibrated and temperature compensated
- Rugged stainless-steel isolated package
- RoHS compliant
- Quality Management System according

Applications

- Industrial measurement
- Industrial control
- Medical devices
- Medical instrumentation

Certificates

- Quality Management System according to EN ISO 13485 and EN ISO 9001
- RoHS and REACH compliant

Media compatibility

Wetted materials:
Stainless steel 316/316 L

[CLICK HERE >](#)
CONNECT WITH A SPECIALIST

SSI SERIES – AMPLIFIED STAINLESS STEEL PRESSURE SENSORS

Specifications

Maximum ratings

Supply voltage V_s	4.5 V to 5.5 V _{DC}	max. 6.50 V _{DC}
Temperature ranges	Compensated	-20 to +85°C
	Storage	-40 to +120 °C
	Operating	-40 to +120 °C
Insulation resistance	100 MΩ at 100 V _{DC}	
Proof pressure ⁽¹⁾	2 x rated pressure	
Burst pressure ⁽²⁾	4 x rated pressure	

Electrical connection

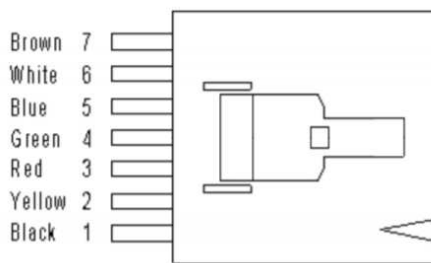

Pin	Connection
1	+Vs
2	GND
3	Vout
4	I/C*
5	SCL
6	SDA
7	I/C*

*internal connection.
Do not connect for any reason.

Specification notes

- (1) Proof pressure is the maximum pressure which may be applied without causing durable shifts of the electrical parameters of the sensing element.
- (2) Burst pressure is the maximum pressure which may be applied without causing damage to the sensing element or leaks to the housing.

SSI SERIES – AMPLIFIED STAINLESS STEEL PRESSURE SENSORS

Performance characteristics

($V_s = 5.0 V_{DC}$, $T_A = 25^\circ C$, analog output signal is ratiometric to V_s , digital output signal is not ratiometric to V_s)

Characteristics	Min.	Typ.	Max.	Units
Total accuracy (-20 to 85 °C) ³			±1.5	%FSS
Response delay ^{4,5}		2		ms
A/D resolution ⁵		13		bit
D/A resolution			11	
Current consumption ⁶		5		mA
ANALOG PERFORMANCE CHARACTERISTIC				
Output at min. specified pressure	0.44	0.55	0.56	V
Full scale span (FSS) ⁷		4.00		
Full scale output	4.44	4.50	4.56	
DIGITAL PERFORMANCE CHARACTERISTIC				
Output at min. specified pressure	2883	3277	3670	counts
Full scale span (FSS) ⁷		26214		
Full scale output	29097	29490	29883	

Specification notes (cont.)

- (3) Total accuracy is the combined error from offset and span calibration, linearity, pressure hysteresis, and temperature effects. Linearity is the measured deviation based on a straight line. Hysteresis is the maximum output difference at any point within the operating pressure range for increasing and decreasing pressure. Calibration errors include the deviation of offset and full scale from nominal values.
- (4) Max. delay time between pressure change at the pressure die and signal change at the output.
- (5) The response time depends on the adjusted internal A/D resolution of the sensor. For 13 bit it is typ. 2 ms. Other A/D resolutions and response time are available on request. Please contact TE Connectivity for further information.
- (6) Sensors with lower current consumption are available on request. Please contact TE Connectivity for further information.
- (7) Full Scale Span (FSS) is the algebraic difference between the output signal for the highest and lowest specified pressure.

I²C BUS

Introduction

The sensor is capable to generate a digital output signal. The device runs a cyclic program, which will store a corrected pressure value with 13-bit resolution about every 500 μs within the output registers of the internal ASIC. In order to use the sensor for digital signal readout, it should be connected to a bidirectional I²C-bus.

According to the I²C-bus specification, the bus is controlled by a master device, which generates the clock signal, controls the bus access and generates START and STOP conditions. The sensor is designed to work as a slave, hence it will only respond to requests from a master device.

Digital I²C interface

The sensor complies with the following protocol (Fig. 1):

Bus not busy: During idle periods both data line (SDA) and clock line (SCL) remain HIGH.

START condition (S): HIGH to LOW transition of SDA line while clock (SCL) is HIGH is interpreted as START condition. START conditions are always generated by the master. Each initial request for a pressure value has to begin with a START condition.

STOP condition (P): LOW to HIGH transition of SDA line while clock (SCL) is HIGH determines STOP condition. STOP conditions are always generated by the master. More than one request for the current pressure value can be transmitted without generation of intermediate STOP condition.

DATA valid (D): State of data line represents valid data when, after START condition, data line is stable for duration of HIGH period of clock signal. Data on line must be changed during LOW period of clock signal. There is one clock pulse per bit of data.

Acknowledge (A): Data is transferred in pieces of 8 bits (1 byte) on serial bus, MSB first. After each byte receiving device – whether master or slave – is obliged to pull data line LOW as acknowledge for reception of data. Master must generate an extra clock pulse for this purpose. When acknowledge is missed, slave transmitter becomes inactive. It is on master either to send last command again or to generate STOP condition in that case.

Slave address: The I²C-bus master-slave concept requires a unique address for each device. The sensor has a preconfigured slave address (1111000xb). By factory programming it is possible to define a secondary slave address additional to the general one. According to I²C specification 127 different addresses are available. The sensor will then listen to both slave addresses. After generating a START condition the master sends the address byte containing a 7-bit address followed by a data direction bit (R/W). A “0” indicates a transmission from master to slave (WRITE), a “1” indicates a data request (READ).

DATA operation: The sensor starts to send 2 data bytes containing the current pressure value as a 15 bit information placed in the output registers.

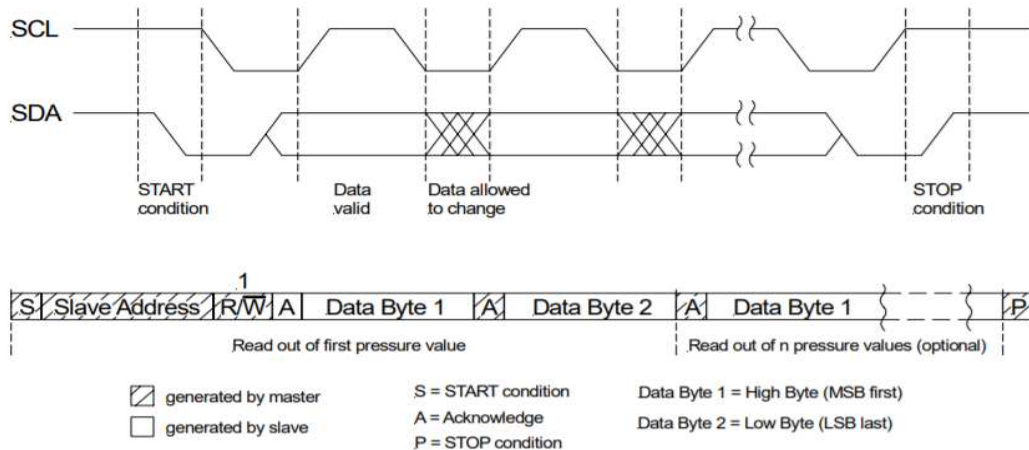

Fig. 1: I²C bus protocol

I²C Interface Parameters

Parameter	Symbol	Min.	Typ.	Max.	Unit
Input high level		90		100	% of Vs
Input low level		0		10	
Output low level				10	
Pull-up resistor		500			Ω
Load capacitance @ SDA	C _{SDA}			400	pF
Input capacitance @ SDA/SCL	C _{I2C_IN}			10	
SCL clock frequency	F _{SCL}	100*		400	kHz
Bus free time between STOP and START condition	t _{BUF}	1.3			μs
Hold time (repeated) START condition, to first clock pulse	t _{HD,STA}	0.8			
LOW period of SCL	t _{LOW}	1.3			
HIGH period of SCL	t _{HIGH}	0.6			
Setup time repeated START condition	t _{SU,STA}	1			
Data hold time	t _{HD,DAT}	0			
Data setup time	T _{SU,DAT}	0.2			
Rise time of both SDA and SCL	t _R			0.3	
Fall time of both SDA and SCL	t _F			0.3	
Setup time for STOP condition	t _{SU,STO}	0.6			

* recommended

Note: TE Connectivity recommends communication speeds of at least 100 kHz (max. 400 kHz). Please contact us for further information.

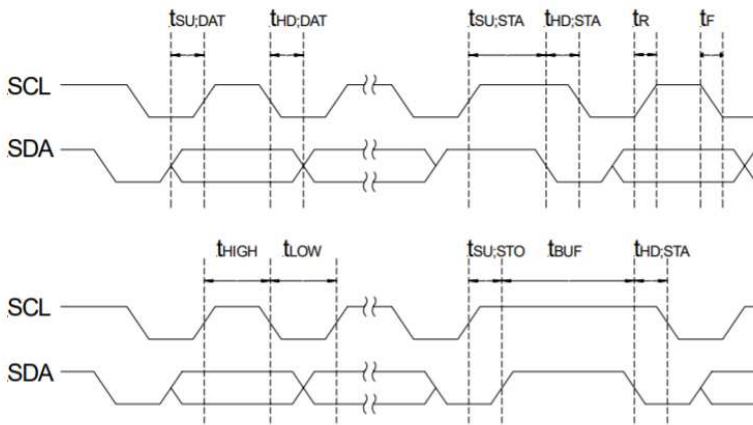
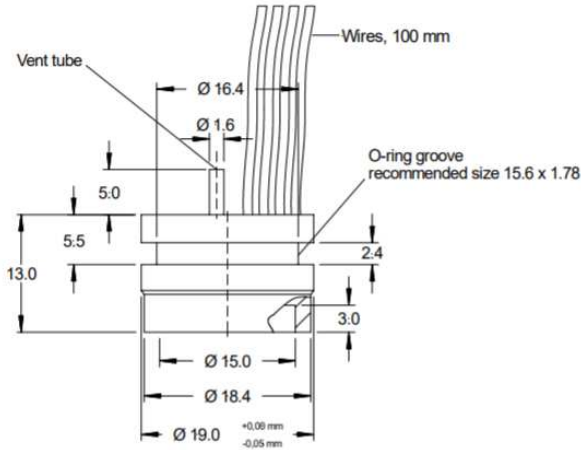

Fig. 2: Timing characteristics

SSI SERIES – AMPLIFIED STAINLESS STEEL PRESSURE SENSORS

Physical dimensions

SSlxxx1 (weld ring)



Do not touch diaphragm

mass: approx. 17 g

dimensions in mm

A clearance fit 19H8 with 20 ° phase is recommended for mounting.

Physical dimensions

SSlxxx5 (1/4 " NPT)

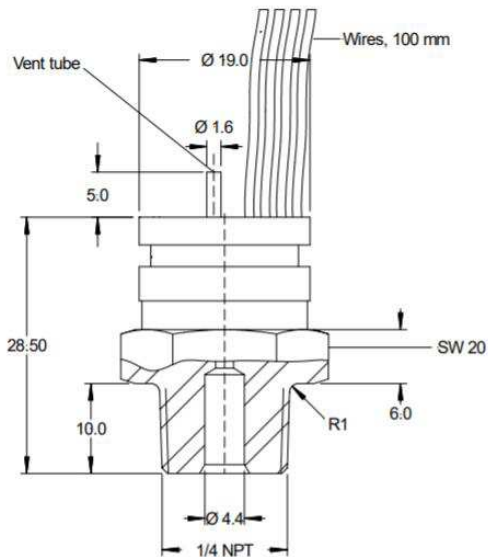

mass: approx. 50 g

dimensions in mm

SSI SERIES – AMPLIFIED STAINLESS STEEL PRESSURE SENSORS

SSIxxx9 (G 1/8" HEX)

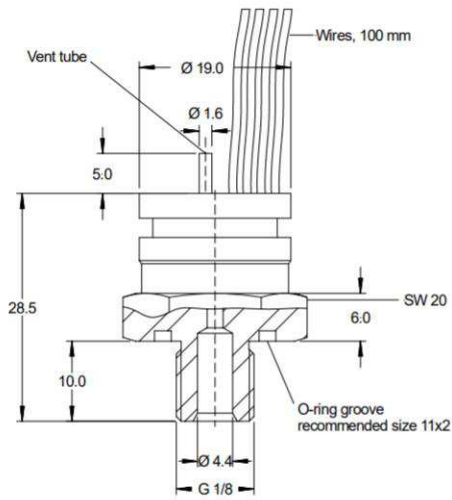

mass: approx. 35 g

dimensions in mm

Optional pressure fitting

SSIxxxN

(1/4" NPT fitting for G 1/8" thread)

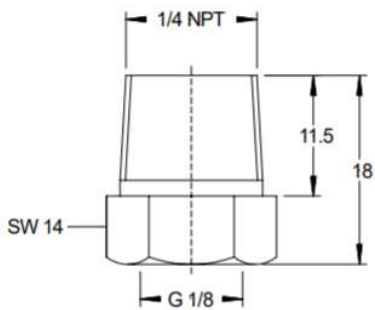

Other fittings are available on request. Please contact TE Connectivity.

SSI SERIES – AMPLIFIED STAINLESS STEEL PRESSURE SENSORS

Part numbering key

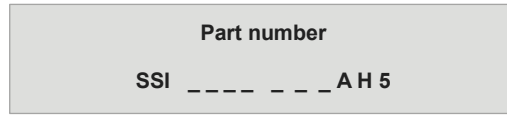

Pressure range

M200	200 mbar
M700	700 mbar
B001	1 bar
B3x5	3.5 bar
B010	10 bar
B020	20 bar
B035	35 bar
P003	3 psi
P010	10 psi
P015	15 psi
P050	50 psi
P150	150 psi
P300	300 psi
P500	500 psi

Pressure mode

A*	Absolute
G	Gage

*only available from 700 mbar.

Calibration

B*	Bidirectional
U	Unidirectional
V**	Vacuum

*only available up to 1 bar

** only available as SSIM200GVxxx (0 to -200 mbar)

Supply

5	5 V
----------	-----

Grade

H	High
----------	------

Electrical connection

A	AMP – MODU*
----------	-------------

*TYCO5-103956-6

Housing

1	Weld ring
5	1/4" NPT
9	G 1/8" HEX
N*	1/4" NPT fitting

*1/4" NPT fitting on G 1/8" thread

Example: SSIB001GU9AH5