



### Main

Range of Product	Harmony Relay
Product or Component Type	Terminal lug
Accessory / separate part category	Mounting accessory
Accessory / separate part destination	SSP1 solid state relay

### Complementary

Material	Copper
AWG gauge	AWG 14...AWG 6
Tightening torque	11.51...15.05 lbf.in (1.3...1.7 N.m)
Wire clamp screw torque	20.36 lbf.in (2.3 N.m)
Net Weight	0.31 oz (8.87 g)
Sale per indivisible quantity	10

### Ordering and shipping details

Category	22375-INTERFACE MODULE(ABA,R,S)
Discount Schedule	CP2
GTIN	3606485442211
Nbr. of units in pkg.	1
Package weight(Lbs)	0.35 oz (10 g)
Returnability	No

### Packing Units

Unit Type of Package 1	PCE
Package 1 Height	1.50 in (3.8 cm)
Package 1 width	1.89 in (4.8 cm)
Package 1 Length	2.56 in (6.5 cm)
Unit Type of Package 2	BB1
Number of Units in Package 2	10
Package 2 Weight	3.53 oz (100 g)
Package 2 Height	1.50 in (3.8 cm)
Package 2 width	1.89 in (4.8 cm)
Package 2 Length	2.56 in (6.5 cm)
Unit Type of Package 3	S01
Number of Units in Package 3	300
Package 3 Weight	7.25 lb(US) (3.29 kg)
Package 3 Height	5.91 in (15 cm)
Package 3 width	5.91 in (15 cm)
Package 3 Length	15.75 in (40 cm)

## Dimensions

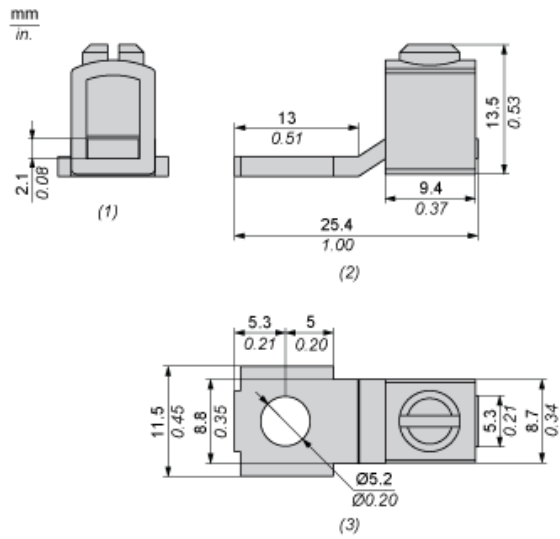

- (1) Side view
- (2) Front view
- (3) Top view