

Features

- Formerly a JENSEN+DEVICES product
- Fast switching rate
- High energy, low loss capability
- Wide operating temperature range
- Long service life
- High insulation resistance
- RoHS compliant*

Applications

- Igniters for architectural and automotive Xenon discharge lamps
- Electronic igniters for gas heating and gas domestic appliances, e.g., cookers
- Ignition of ultra-high pressure gas discharge lamps for data and video projectors

Sparctube™ Switching Spark Gap ST-1000 Series

Description

Bourns® Sparctube™ Switching Spark Gap Series is a range of switching spark gaps designed specifically for voltage controlled switching of capacitive discharge circuits where a high energy, low loss, fast rate of switching is required. This series is ideally suited for applications where a capacitive discharge is utilized with a transformer to obtain pulses of very high voltage levels in the order of several thousand volts.

Characteristics

Initial Values:

Static Breakdown Voltage @ 800 V/s ¹

First Ignition Values	< 1200 V
Following Ignition Values	1000 V ±15 %

Electrical Life:

Minimum Number of Switching Cycles	2x10 ⁵
Peak Current (Approx.)	400 A
Maximum Switching Frequency	400 Hz
Breakdown Characteristics @ 1400 V Limit	
First Ignition Values	≤ 1400 V
Delay Time	< 60 ms
Following Ignition Values	1000 V ±20 %

General Data:

Breakdown Time	< 50 ns
Insulation Resistance @100 Vdc	> 100 megohms
Share of Early Ignition Values (< 800 V)	< 1 %
Capacitance	< 1 pF
Operating Temperature Range ²	-40 °C to +160 °C
Storage Temperature Range	-65 °C to +125 °C
Weight (Approx.)	2.3 g
Testing	100 %
Robustness of Terminations	IEC 60068-2-21 ³

Notes:

- ¹ At delivery AQL 0.65 Level II, DIN ISO 2859.
- ² Distribution of switchings: maximum 20 % above +125 °C and 20 % below +20°C.
- ³ Test Ua1 (tensile), Ua2 (thrust), Ub (bending) and Uc (torsion).

Basic Application Circuit

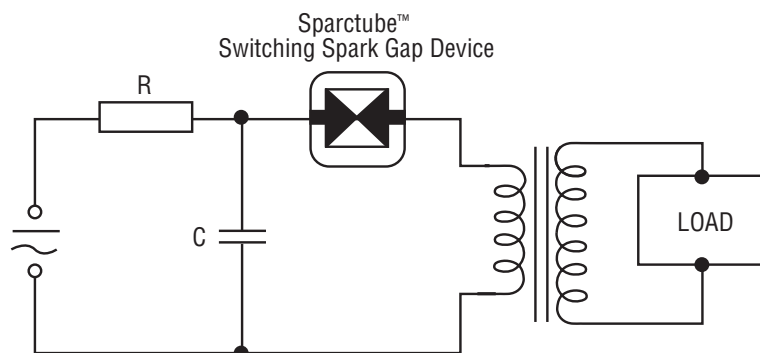

BOURNS®

Asia-Pacific:

Tel: +886-2 2562-4117
Fax: +886-2 2562-4116

EMEA:

Tel: +36 88 520 390
Fax: +36 88 520 211

The Americas:

Tel: +1-951 781-5500
Fax: +1-951 781-5700

www.bourns.com

*RoHS Directive 2002/95/EC Jan. 27, 2003 including annex and RoHS Recast 2011/65/EU June 8, 2011.

Specifications are subject to change without notice.

The device characteristics and parameters in this data sheet can and do vary in different applications and actual device performance may vary over time. Users should verify actual device performance in their specific applications.

Product Dimensions

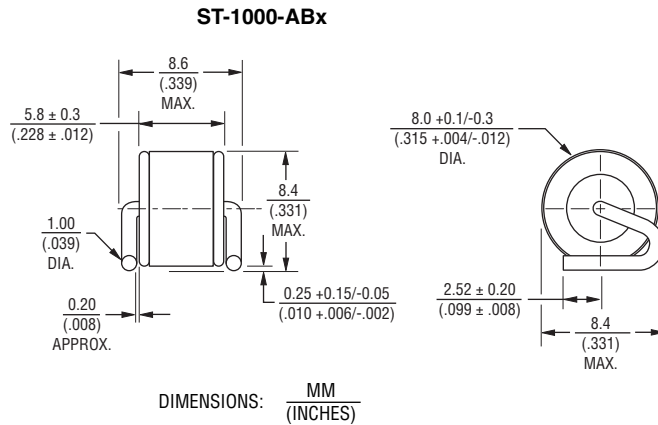
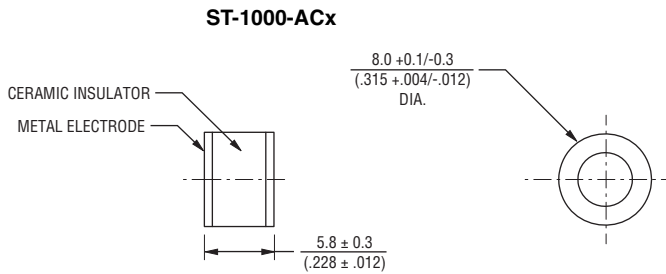
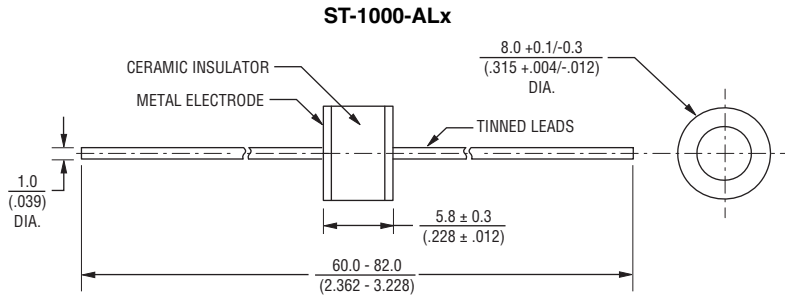

How to Order

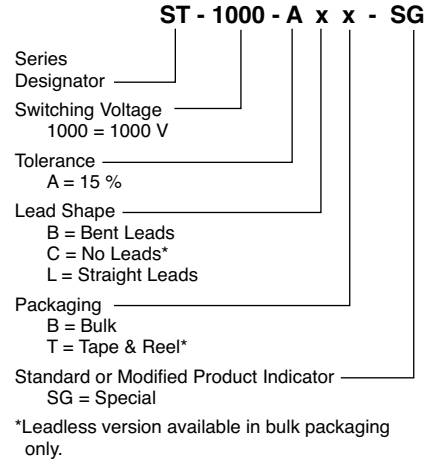

Typical Part Marking

B ST 1000 wwy “wwy” = Week and year of production

Recommended Pad Layout

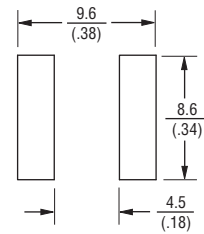

Test Circuit

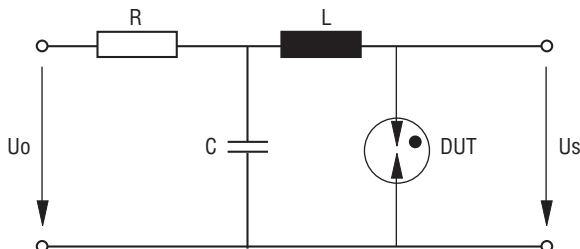

- U_o 1400 V
- R See Note
- C 100 nF
- L 0.5 μ H
- DUT Device Under Test
- U_s Breakdown Voltages

NOTE: U_o and R are set to provide suitable conditions for different measurements.

Specifications are subject to change without notice. The device characteristics and parameters in this data sheet can and do vary in different applications and actual device performance may vary over time. Users should verify actual device performance in their specific applications.