



ST3222B ST3222C

3 to 3.6 V, low power, up to 400 kbps
RS-232 drivers and receivers

Features

- 300 μ A supply current
- 250 kbps minimum guarantee data rate
- 6 V/ μ s minimum guarantee slew rate
- Meet EIA/TIA-232 specification down to 3 V

Description

The ST3222 is a 3 V powered EIA/TIA-232 and V.28/V.24 communications interface with low power requirements and high data-rate capabilities. ST3222 has a proprietary low dropout transmitter output stage providing true RS-232 performance from 3 to 3.6 V power supplies. The device requires only four small 0.1 mF standard external capacitors for operating from 3 V supply. The ST3222 has two receivers and two drivers. The ST3222 features a 1 mA shutdown mode that reduces power consumption and extends battery life in portable systems. Its receivers can remain active in shutdown mode, allowing external devices such as modems to be monitored using only 1 mA supply current. The device is guaranteed to run at data rates of 250 Kbps while maintaining RS-232 output levels. Typical applications are notebooks, sub-notebooks and palmtop computers, battery powered equipment, hand-held equipment, peripherals and printers.

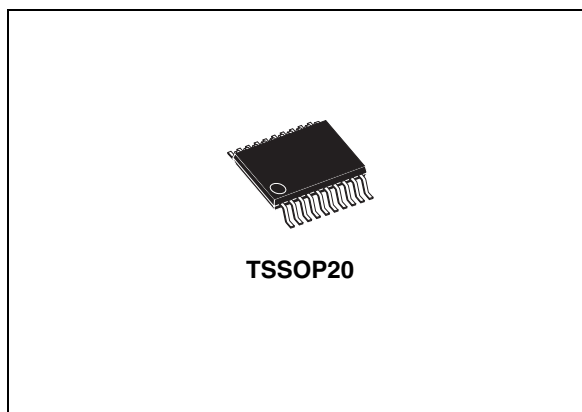

Table 1. Device summary

Order codes	Temperature range	Package	Packaging
ST3222CTR	0 to 70 °C	TSSOP20 (tape and reel)	2500 parts per reel
ST3222BTR	-40 to 85 °C	TSSOP20 (tape and reel)	2500 parts per reel

Contents

1	Pin configuration	3
2	Maximum ratings	4
3	Electrical characteristics	5
3.1	Receiver electrical characteristics	6
4	Application	7
4.1	Typical performance characteristics	8
5	Package mechanical data	9
6	Revision history	12

1 Pin configuration

Figure 1. Pin connections

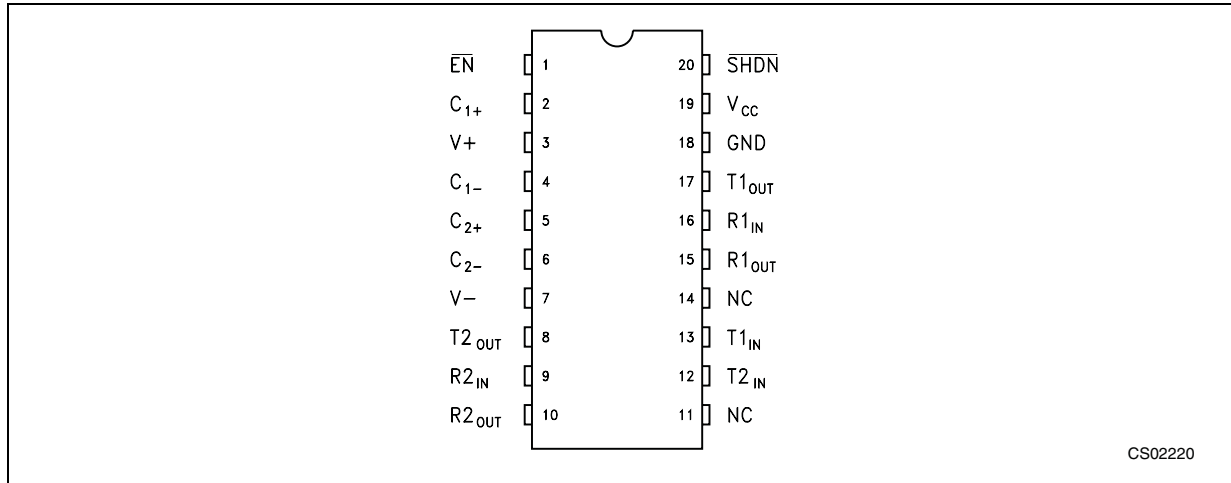

Table 2. Pin descriptions

Pin n°	Symbol	Name and function
1	EN	Receiver enable control. Drive low for normal operation. Drive high to force the receivers outputs (R_OUT) into a high-impedance state.
2	C ₁₊	Positive terminal for the first charge pump capacitor
3	V+	5.5 V Generated by the charge pump.
4	C ₁₋	Negative terminal for the first charge pump capacitor
5	C ₂₊	Positive terminal for the second charge pump capacitor
6	C ₂₋	Negative terminal for the second charge pump capacitor
7	V-	-5.5 V Generated by the charge pump.
8	T2 _{OUT}	Second transmitter output voltage
9	R2 _{IN}	Second receiver Input voltage
10	R2 _{OUT}	Second receiver output voltage
11	NC	Not connected
12	T2 _{IN}	Second transmitter input voltage
13	T1 _{IN}	First transmitter Input voltage
14	NC	Not connected
15	R1 _{OUT}	First receiver output voltage
16	R1 _{IN}	First receiver input voltage
17	T1 _{OUT}	First transmitter output voltage
18	GND	Ground
19	V _{CC}	Supply voltage
20	SHDN	Active low shutdown control input. Drive low to shutdown transmitter and charge pump

2 Maximum ratings

Table 3. Absolute maximum ratings

Symbol	Parameter	Value	Unit
V_{CC}	Supply voltage	-0.3 to 6	V
$V+$	Doubled voltage terminal	$(V_{CC} - 0.3)$ to 7	V
$V-$	Inverted voltage terminal	0.3 to -7	V
$V+ + V- $		13	V
T_{IN}	Transmitter input voltage range	-0.3 to 6	V
R_{IN}	Receiver input voltage range	± 25	V
T_{OUT}	Transmitter output voltage range	± 13.2	V
R_{OUT}	Receiver output voltage range	-0.3 to $(V_{CC} + 0.3)$	V
t_{SHORT}	Transmitter output short to gnd time	Continuous	

Note: Absolute maximum ratings are those values beyond which damage to the device may occur. Functional operation under these condition is not implied.

Externally applied $V+$ and $V-$ can have a maximum magnitude of +7 V, but their absolute addition can not exceed 13 V.

Running on internal charge pump, intrinsic self limitation allows exceeding those values without any damage.

Startup voltage sequence (V_{CC} , then $V+$, then $V-$) is critical, therefore it is not recommended to use this device using externally applied voltage to $V+$ and $V-$.

3 Electrical characteristics

Table 4. Electrical characteristics ($C_1 - C_4 = 0.1 \mu\text{F}$, $V_{\text{CC}} = 3 \text{ V}$ to 3.6 V , $T_A = -40$ to $85 \text{ }^\circ\text{C}$, unless otherwise specified. Typical values are referred to $T_A = 25 \text{ }^\circ\text{C}$)

Symbol	Parameter	Test conditions	Min.	Typ.	Max.	Unit
I_{SUPPLY}	V_{CC} power supply current	No load $V_{\text{CC}} = 3.3 \text{ V}$ $T_A = 25 \text{ }^\circ\text{C}$ $\overline{\text{SHDN}} = V_{\text{CC}}$		0.3	1	mA
I_{SHDN}	SHUTDOWN supply current	No load $V_{\text{CC}} = 3.3 \text{ V}$ $T_A = 25 \text{ }^\circ\text{C}$ $\overline{\text{SHDN}} = \text{GND}$		1	10	μA

Table 5. Logic input electrical characteristics ($C_1 - C_4 = 0.1 \mu\text{F}$, $V_{\text{C}} = 3 \text{ V}$ to 3.6 V , $T_A = -40$ to $85 \text{ }^\circ\text{C}$, unless otherwise specified. Typical values are referred to $T_A = 25 \text{ }^\circ\text{C}$)

Symbol	Parameter	Test conditions	Min.	Typ.	Max.	Unit
V_{IL}	Input logic threshold low	T-IN, $\overline{\text{EN}}$, $\overline{\text{SHDN}}$ (<i>Note:</i>)			0.8	V
V_{IH}	Input logic threshold high	$V_{\text{CC}} = 3.3 \text{ V}$	2			V
V_{HYS}	Transmitter input hysteresis			0.5		V
I_{IL}	Input leakage current	T-IN, $\overline{\text{EN}}$, $\overline{\text{SHDN}}$		± 0.01	± 1	μA

Note: Transmitter input hysteresis is typically 250 mV

Table 6. Transmitter electrical characteristics ($C_1 - C_4 = 0.1 \mu\text{A}$, $V_{\text{CC}} = 3 \text{ V}$ to 3.6 V , $T_A = -40$ to $85 \text{ }^\circ\text{C}$, unless otherwise specified. Typical values are referred to $T_A = 25 \text{ }^\circ\text{C}$)

Symbol	Parameter	Test conditions	Min.	Typ.	Max.	Unit
V_{TOUT}	Output voltage swing	All transmitter outputs are loaded with $3 \text{ k}\Omega$ to GND	± 5	± 5.4		V
R_{TOUT}	Transmitter output resistance	$V_{\text{CC}} = V_+ = V_- = 0 \text{ V}$, $V_{\text{OUT}} = \pm 2 \text{ V}$	300	10M		Ω
I_{TSC}	Output short circuit current				± 60	mA
I_{TOL}	Output leakage current	$V_{\text{CC}} = 0 \text{ V}$ or 3 V to 3.6 V , $V_{\text{OUT}} = \pm 12 \text{ V}$ Transmitters disable			± 25	μA

3.1 Receiver electrical characteristics

Table 7. Receiver electrical characteristics ($C_1 - C_4 = 0.1 \mu\text{F}$, $V_{\text{CC}} = 3 \text{ V to } 3.6 \text{ V}$, $T_A = -40 \text{ to } 85 \text{ }^\circ\text{C}$, unless otherwise specified. Typical values are referred to $T_A = 25 \text{ }^\circ\text{C}$)

Symbol	Parameter	Test conditions	Min.	Typ.	Max.	Unit
I_{OL}	Output leakage current	R-OUT, $\overline{\text{EN}} = V_{\text{CC}}$, receiver disabled		± 0.05	± 10	μA
V_{RIN}	Receiver Input voltage operating range		-25		25	V
V_{RIL}	Input threshold low	$T_A = 25 \text{ }^\circ\text{C}$, $V_{\text{CC}} = 3.3 \text{ V}$	0.6	1.2		V
V_{RIH}	Input threshold high	$T_A = 25 \text{ }^\circ\text{C}$, $V_{\text{CC}} = 3.3 \text{ V}$		1.5	2.4	V
V_{RIHYS}	Input hysteresis			0.5		V
R_{RIN}	Input resistance	$T_A = 25 \text{ }^\circ\text{C}$	3	5	7	$\text{k}\Omega$
V_{ROL}	TTL/CMOS output voltage low	$I_{\text{OUT}} = 1.6 \text{ mA}$			0.4	V
V_{ROH}	TTL/CMOS output voltage high	$I_{\text{OUT}} = -1 \text{ mA}$	$V_{\text{CC}}-0.6$	$V_{\text{CC}}-0.1$		V

Table 8. Timing characteristics ($C_1 - C_4 = 0.1 \mu\text{F}$, $V_{\text{CC}} = 3 \text{ V to } 3.6 \text{ V}$, $T_A = -40 \text{ to } 85 \text{ }^\circ\text{C}$, unless otherwise specified. Typical values are referred to $T_A = 25 \text{ }^\circ\text{C}$)

Symbol	Parameter	Test conditions	Min.	Typ.	Max.	Unit
D_{R}	Data transfer rate	$R_L = 3 \text{ k}\Omega$ $C_{L2} = 1000 \text{ pF}$ one transmitter switching	240	400		Kbps
t_{PHLR} t_{PLHR}	Propagation delay input to output	R_{XIN} to R_{XOUT} , $C_L = 150 \text{ pF}$		0.2		μs
$ t_{\text{PHLT}} - t_{\text{THL}} $	Transmitter propagation delay difference (1)			100		ns
t_{OER}	Receiver output enable time	Normal operation		200		ns
t_{ODR}	Receiver output disable time	Normal operation		200		ns
$ t_{\text{PHLR}} - t_{\text{THR}} $	Receiver propagation delay difference			50		ns
S_{RT}	Transition slew rate	$T_A = 25 \text{ }^\circ\text{C}$, $R_L = 3 \text{ k}\Omega$ to $7 \text{ k}\Omega$, $V_{\text{CC}} = 3.3 \text{ V}$ measured from $+3 \text{ V to } -3 \text{ V}$ or $-3 \text{ V to } +3 \text{ V}$ $C_L = 150 \text{ pF to } 1000 \text{ pF}$ $C_L = 150 \text{ pF to } 2500 \text{ pF}$	6 4		30 30	$\text{V}/\mu\text{s}$ $\text{V}/\mu\text{s}$

1. Transmitter skew is measured at the transmitter zero cross points

4 Application

Figure 2. Application circuits

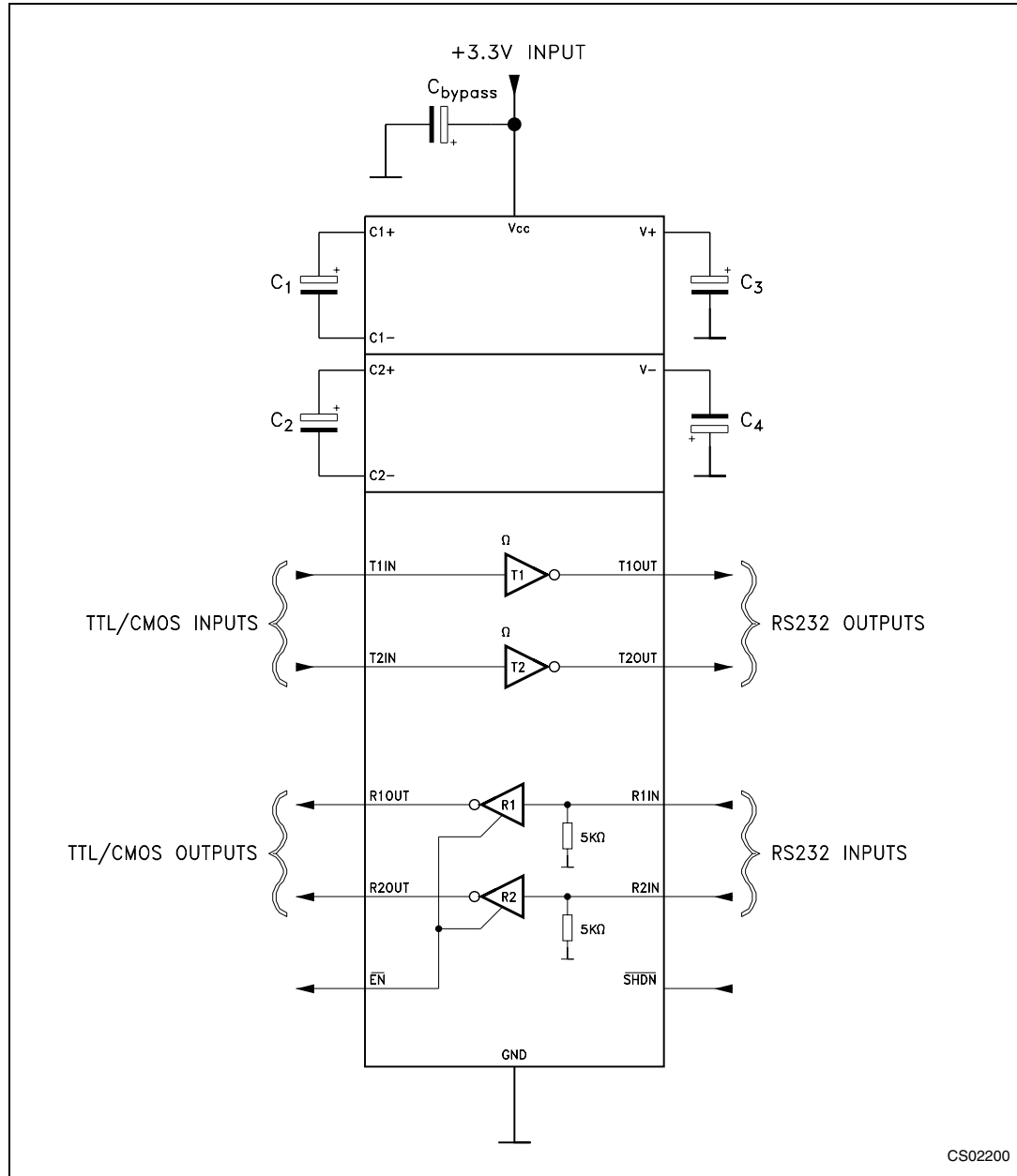

Table 9. Capacitance value (µF)

C1	C2	C3	C4	C _{bypass}
0.1	0.1	0.1	0.1	0.1

4.1 Typical performance characteristics

(unless otherwise specified $T_J = 25\text{ }^\circ\text{C}$)

Figure 3. Driver voltage transfer characteristics for transmitter inputs

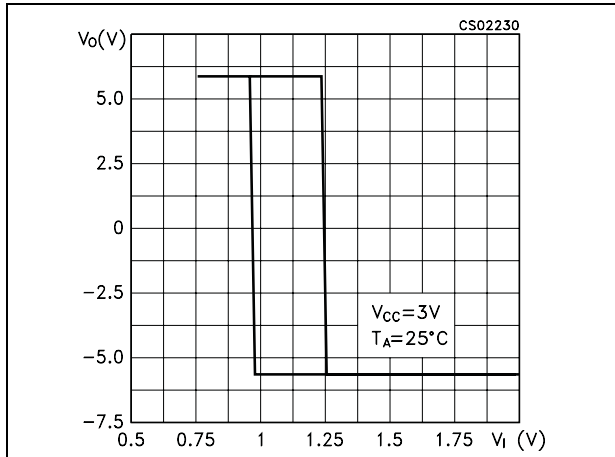

Figure 4. Driver voltage transfer characteristics for receiver inputs

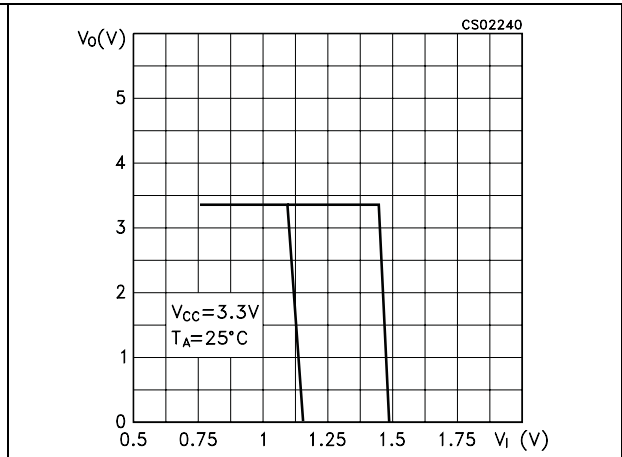

Figure 5. Output current vs. output low voltage

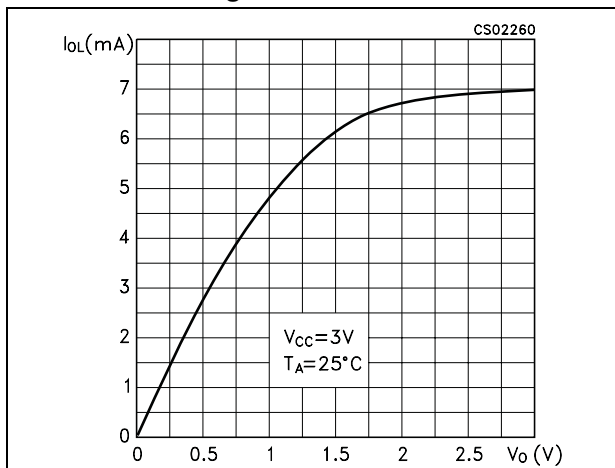
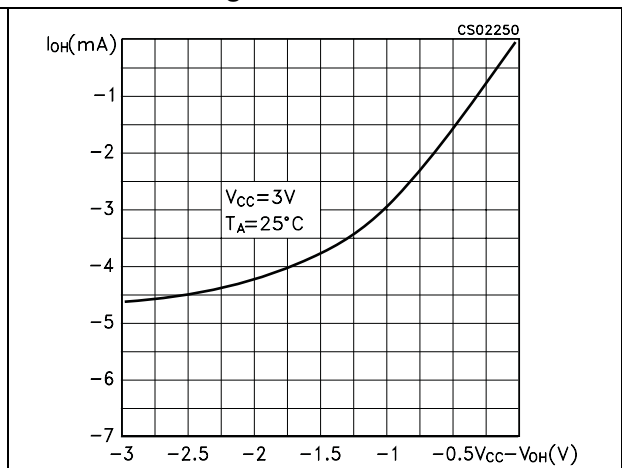

Figure 6. Output current vs. output high voltage



5 Package mechanical data

In order to meet environmental requirements, ST offers these devices in different grades of ECOPACK[®] packages, depending on their level of environmental compliance. ECOPACK[®] specifications, grade definitions and product status are available at: www.st.com. ECOPACK[®] is an ST trademark.

Table 10. TSSOP20 package mechanical data

Dim.	mm.			in.		
	Min.	Typ.	Max.	Min.	Typ.	Max.
A			1.2			0.047
A1	0.05		0.15	0.002	0.004	0.006
A2	0.8	1	1.05	0.031	0.039	0.041
b	0.19		0.30	0.007		0.012
c	0.09		0.20	0.004		0.0079
D	6.4	6.5	6.6	0.252	0.256	0.260
E	6.2	6.4	6.6	0.244	0.252	0.260
E1	4.3	4.4	4.48	0.169	0.173	0.176
e		0.65 BSC			0.0256 BSC	
K	0°		8°	0°		8°
L	0.45	0.60	0.75	0.018	0.024	0.030

Figure 7. TSSOP20 package mechanical drawing

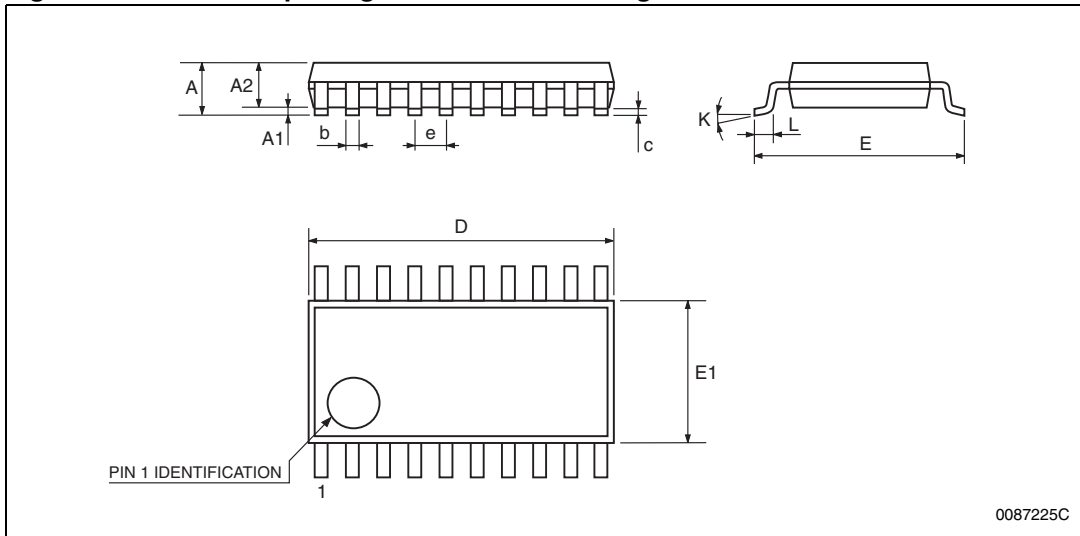
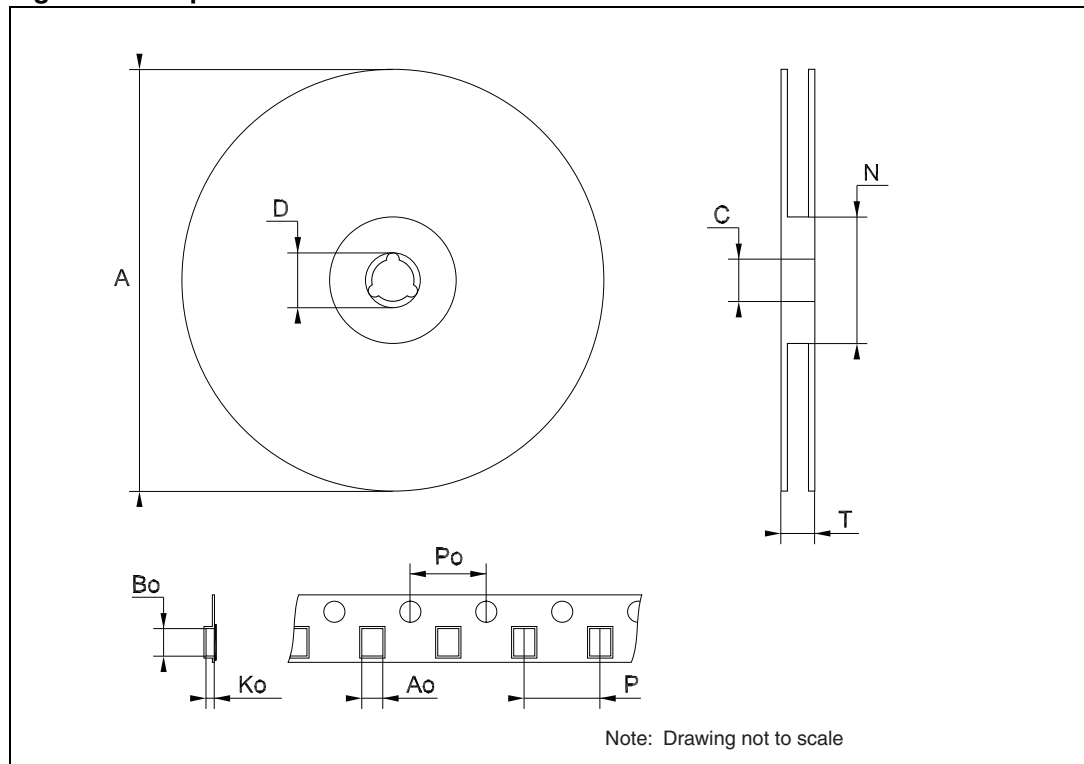

Table 11. Tape and reel TSSOP20 mechanical data

Dim.	mm.			in.		
	Min.	Typ.	Max.	Min.	Typ.	Max.
A			330			12.992
C	12.8		13.2	0.504		0.519
D	20.2			0.795		
N	60			2.362		
T			22.4			0.882
A ₀	6.8		7	0.268		0.276
B ₀	6.9		7.1	0.272		0.280
K ₀	1.7		1.9	0.067		0.075
P ₀	3.9		4.1	0.153		0.161
P	11.9		12.1	0.468		0.476

Figure 8. Tape and reel schematic TSSOP20



6 Revision history

Table 12. Document revision history

Date	Revision	Changes
22-Mar-2006	5	Order codes updated.
21-Jan-2008	6	Modified: Table 3 and added Table 1 .
25-Aug-2010	7	Updated Table 4 , ECOPACK [®] text in Section 5: Package mechanical data ; reformatted document, minor textual changes.