

± 15 kV ESD protected, 3 to 5.5 V
low power, up to 250 Kbps, RS-232 drivers and receivers

Features

- ESD protection for RS-232 I/O pins ± 15 kV human body model, ± 8 kV IEC 1000-4-2 contact discharge
- 300 µA supply current
- 250Kbps minimum guarantee data rate
- 6 V/µs minimum guarantee slew rate
- Meet EIA/TIA-232 specification down to 3 V
- Available in SSOP20 and TSSOP20

Description

The ST3222E is a 3 V powered EIA/TIA-232 and V.28/V.24 communications interface with low power requirements, high data-rate capabilities and enhanced electrostatic discharge (ESD) protection to ± 8 kV using IEC1000-4-2 Contact Discharge and ±15 kV using the Human Body Model. ST3222E has a proprietary low dropout transmitter output stage providing true RS-232 performance from 3 to 5 V supplies with a dual charge pump. The charge pump requires only four small 0.1 mF external capacitors for operation from 3 V supply. The device has two receivers and two drivers. The ST3222E features a 1 mA shutdown mode that reduces power consumption and extends battery life in portable systems. Its receivers can remain active in shutdown mode, allowing external devices such as modems to be monitored using only 1 mA supply current. The device is guaranteed to run at data rates of 250 Kbps while maintaining RS-232 output levels.

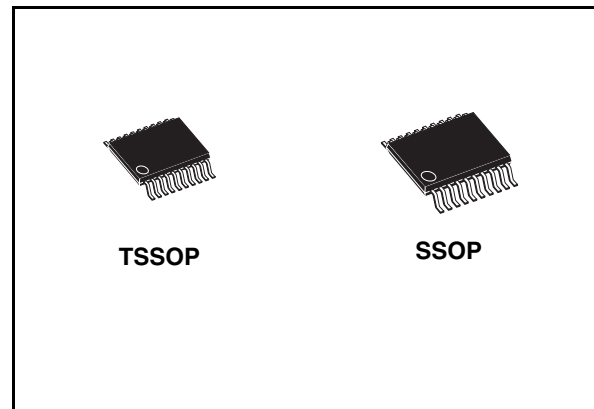

Typical applications are Notebook, Sub-notebook and Palmtop Computers, Battery Powered Equipment, Hand-Held Equipment, Peripherals and Printers.

Table 1. Device summary

Order codes	Temperature range	Package	Packaging
ST3222ECPR	0 to 70 °C	SSOP20 (tape and reel)	1350 parts per reel
ST3222EBPR	-40 to 85 °C	SSOP20 (tape and reel)	1350 parts per reel
ST3222ECTR	0 to 70 °C	TSSOP20 (tape and reel)	2500 parts per reel
ST3222EBTR	-40 to 85 °C	TSSOP20 (tape and reel)	2500 parts per reel

Contents

1	Pin configuration	3
2	Absolute maximum ratings	4
3	Electrical characteristics	5
4	Application circuits	7
5	Typical performance characteristics	8
6	Package mechanical data	9
7	Revision history	14

1 Pin configuration

Figure 1. Pin connection

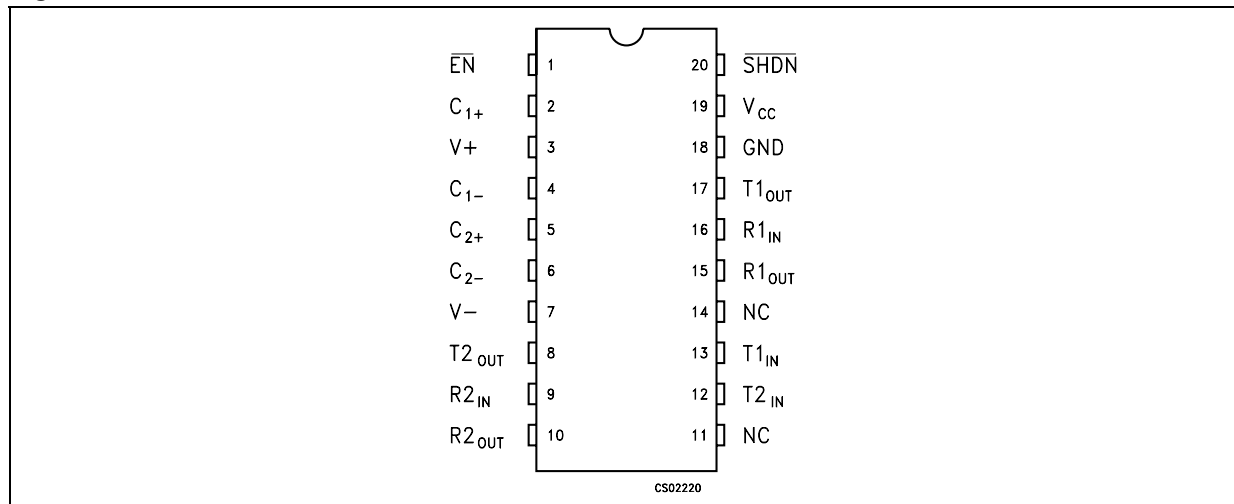

Table 2. Pin description

Pin n°	Symbol	Name and function
1	EN	Receiver enable control. drive low for normal operation. Drive high to force the receivers outputs (R_OUT) into a high-impedance state.
2	C ₁₊	Positive terminal for the first charge pump capacitor
3	V+	5.5V Generated by the charge pump.
4	C ₁₋	Negative terminal for the first charge pump capacitor
5	C ₂₊	Positive terminal for the second charge pump capacitor
6	C ₂₋	Negative terminal for the second charge pump capacitor
7	V-	-5.5V Generated by the charge pump.
8	T2 _{OUT}	Second transmitter output voltage
9	R2 _{IN}	Second receiver input voltage
10	R2 _{OUT}	Second receiver output voltage
11	NC	Not connected
12	T2 _{IN}	Second transmitter input voltage
13	T1 _{IN}	First transmitter input voltage
14	NC	Not connected
15	R1 _{OUT}	First receiver output voltage
16	R1 _{IN}	First receiver input voltage
17	T1 _{OUT}	First transmitter output voltage
18	GND	Ground
19	V _{CC}	Supply voltage
20	SHDN	Active low shutdown control input. drive low to shut-down transmitter and charge pump

2 Absolute maximum ratings

Table 3. Absolute maximum ratings

Symbol	Parameter	Value	Unit
V_{CC}	Supply voltage	-0.3 to 6	V
V+	Doubled voltage terminal	$(V_{CC} - 0.3)$ to 7	V
V-	Inverted voltage terminal	0.3 to -7	V
$V+ + V- $		13	V
T_{IN}	Transmitter input voltage range	-0.3 to 6	V
R_{IN}	Receiver input voltage range	± 25	V
T_{OUT}	Transmitter output voltage range	± 13.2	V
R_{OUT}	Receiver output voltage range	-0.3 to $(V_{CC} + 0.3)$	V
t_{SHORT}	Transmitter output short to gnd time	Continuous	

Note: Absolute maximum ratings are those values beyond which damage to the device may occur. Functional operation under these condition is not implied.

Externally applied V+ and V- can have a maximum magnitude of +7 V, but their absolute addition can not exceed 13 V.

Running on internal charge pump, intrinsic self limitation allows exceeding those values without any damage.

Startup voltage sequence (V_{CC} , then V+, then V-) is critical, therefore it is not recommended to use this device using externally applied voltage to V+ and V-.

Table 4. Shutdown and enable control truth table

SHDN	EN	T-OUT	R-OUT
0	0	High Z	Active
0	1	High Z	High Z
1	0	Active	Active
1	1	Active	High Z

Table 5. ESD performance: transmitter outputs, receiver inputs

Symbol	Parameter	Test conditions	Min.	Typ.	Max.	Unit
ESD	ESD protection voltage	Human body model	± 15			kV
ESD	ESD protection voltage	IEC-1000-4-2	± 8			kV

3 Electrical characteristics

Table 6. Electrical characteristics ($C_1 - C_4 = 0.1 \mu\text{F}$, $V_{\text{CC}} = 3 \text{ V to } 5.5 \text{ V}$, $T_A = -40 \text{ to } 85 \text{ }^\circ\text{C}$, unless otherwise specified. Typical values are referred to $T_A = 25 \text{ }^\circ\text{C}$)

Symbol	Parameter	Test conditions	Min.	Typ.	Max.	Unit
I_{SUPPLY}	V_{CC} power supply current	No load, $\overline{\text{SHDN}} = V_{\text{CC}}$, $T_A = 25^\circ\text{C}$		0.3	1	mA
I_{SHDN}	Shutdown supply current	No load, $\overline{\text{SHDN}} = V_{\text{CC}}$, $T_A = 25^\circ\text{C}$		1	10	μA

Table 7. Logic input electrical characteristics ($C_1 - C_4 = 0.1 \mu\text{F}$, $V_{\text{CC}} = 3 \text{ V to } 5.5 \text{ V}$, $T_A = -40 \text{ to } 85 \text{ }^\circ\text{C}$, unless otherwise specified. Typical values are referred to $T_A = 25 \text{ }^\circ\text{C}$)

Symbol	Parameter	Test conditions	Min.	Typ.	Max.	Unit
V_{IL}	Input logic threshold low	T-IN, $\overline{\text{EN}}$, $\overline{\text{SHDN}}$ (<i>Note: 1</i>)			0.8	V
V_{IH}	Input logic threshold high	$V_{\text{CC}} = 3.3 \text{ V}$	2			V
		$V_{\text{CC}} = 5 \text{ V}$	2.4			
V_{HYS}	Transmitter input hysteresis			0.25		V
I_{IL}	Input leakage current	T-IN, $\overline{\text{EN}}$, $\overline{\text{SHDN}}$		± 0.01	± 1	μA

Note: 1 Transmitter input hysteresis is typically 250 mV

Table 8. Transmitter electrical characteristics ($C_1 - C_4 = 0.1 \mu\text{F}$, $V_{\text{CC}} = 3 \text{ V to } 5.5 \text{ V}$, $T_A = -40 \text{ to } 85 \text{ }^\circ\text{C}$, unless otherwise specified. Typical values are referred to $T_A = 25 \text{ }^\circ\text{C}$)

Symbol	Parameter	Test conditions	Min.	Typ.	Max.	Unit
V_{TOUT}	Output voltage swing	All transmitter outputs are loaded with $3 \text{ K}\Omega$ to GND	± 5	± 5.4		V
R_{TOUT}	Transmitter output resistance	$V_{\text{CC}} = V_+ = V_- = 0 \text{ V}$, $V_{\text{OUT}} = \pm 2 \text{ V}$	300	10M		Ω
I_{TSC}	Output short circuit current			± 60		mA
I_{TOL}	Output leakage current	$V_{\text{CC}} = 0 \text{ or } 3 \text{ V to } 3.6 \text{ V}$, $V_{\text{OUT}} = \pm 12 \text{ V}$ Transmitters disable			± 25	μA

Table 9. Receiver electrical characteristics ($C_1 - C_4 = 0.1 \mu\text{F}$, $V_{\text{CC}} = 3 \text{ V to } 5.5 \text{ V}$, $T_A = -40 \text{ to } 85 \text{ }^\circ\text{C}$, unless otherwise specified. Typical values are referred to $T_A = 25 \text{ }^\circ\text{C}$)

Symbol	Parameter	Test conditions	Min.	Typ.	Max.	Unit
I_{OL}	Output leakage current	R-OUT, $\overline{\text{EN}} = V_{\text{CC}}$, receiver disabled		± 0.05	± 10	μA
V_{RIN}	Receiver input voltage operating range		-25		25	V
V_{RIL}	Input threshold low	$T_A = 25^\circ\text{C}$, $V_{\text{CC}} = 3.3 \text{ V}$	0.6	1.2		V
		$T_A = 25^\circ\text{C}$, $V_{\text{CC}} = 5 \text{ V}$	0.8	1.5		
V_{RIH}	Input threshold high	$T_A = 25^\circ\text{C}$, $V_{\text{CC}} = 3.3 \text{ V}$		1.5	2.4	V
		$T_A = 25^\circ\text{C}$, $V_{\text{CC}} = 5 \text{ V}$		1.8	2.4	
V_{RIHYS}	Input hysteresis			0.5		V
R_{RIN}	Input resistance	$T_A = 25^\circ\text{C}$	3	5	7	$\text{K}\Omega$
V_{ROL}	Output voltage low	$I_{\text{OUT}} = 1.6 \text{ mA}$			0.4	V
V_{ROH}	Output voltage high	$I_{\text{OUT}} = -1 \text{ mA}$	$V_{\text{CC}} - 0.6$	$V_{\text{CC}} - 0.1$		V

Table 10. Timing characteristics ($C_1 - C_4 = 0.1 \mu\text{F}$, $V_{\text{CC}} = 3 \text{ V to } 5.5 \text{ V}$, $T_A = -40 \text{ to } 85 \text{ }^\circ\text{C}$, unless otherwise specified. Typical values are referred to $T_A = 25 \text{ }^\circ\text{C}$)

Symbol	Parameter	Test conditions	Min.	Typ.	Max.	Unit
D_{R}	Data transfer rate	$R_{\text{L}} = 3 \text{ K}\Omega$, $C_{\text{L}2} = 1000 \text{ pF}$ one transmitter switching	250			Kbps
t_{PHLR} t_{PLHR}	Propagation delay input to output	R_{XIN} to R_{XOUT} , $C_{\text{L}} = 150 \text{ pF}$		0.15		μs
$ t_{\text{PHLT}} - t_{\text{THL}} $	Transmitter propagation delay difference ⁽¹⁾			200		ns
t_{OER}	Receiver output enable time	Normal operation		50		ns
t_{ODR}	Receiver output disable time	Normal operation		50		ns
$ t_{\text{PHLR}} - t_{\text{THR}} $	Receiver propagation delay difference			50		ns
S_{RT}	Transition slew rate	$T_A = 25^\circ\text{C}$ $R_{\text{L}} = 3 \text{ K}\Omega$ to $7 \text{ K}\Omega$ $V_{\text{CC}} = 3.3 \text{ V}$ measured from +3V to -3V or -3V to +3V $C_{\text{L}} = 150 \text{ pF}$ to 1000 pF	6		30	$\text{V}/\mu\text{s}$
		$T_A = 25^\circ\text{C}$ $R_{\text{L}} = 3 \text{ K}\Omega$ to $7 \text{ K}\Omega$ $V_{\text{CC}} = 3.3 \text{ V}$ measured from +3V to -3V or -3V to +3V $C_{\text{L}} = 150 \text{ pF}$ to 2500 pF	4		30	$\text{V}/\mu\text{s}$

1. Transmitter Skew is measured at the transmitter zero cross points

4 Application circuits

Figure 2. Application schematic

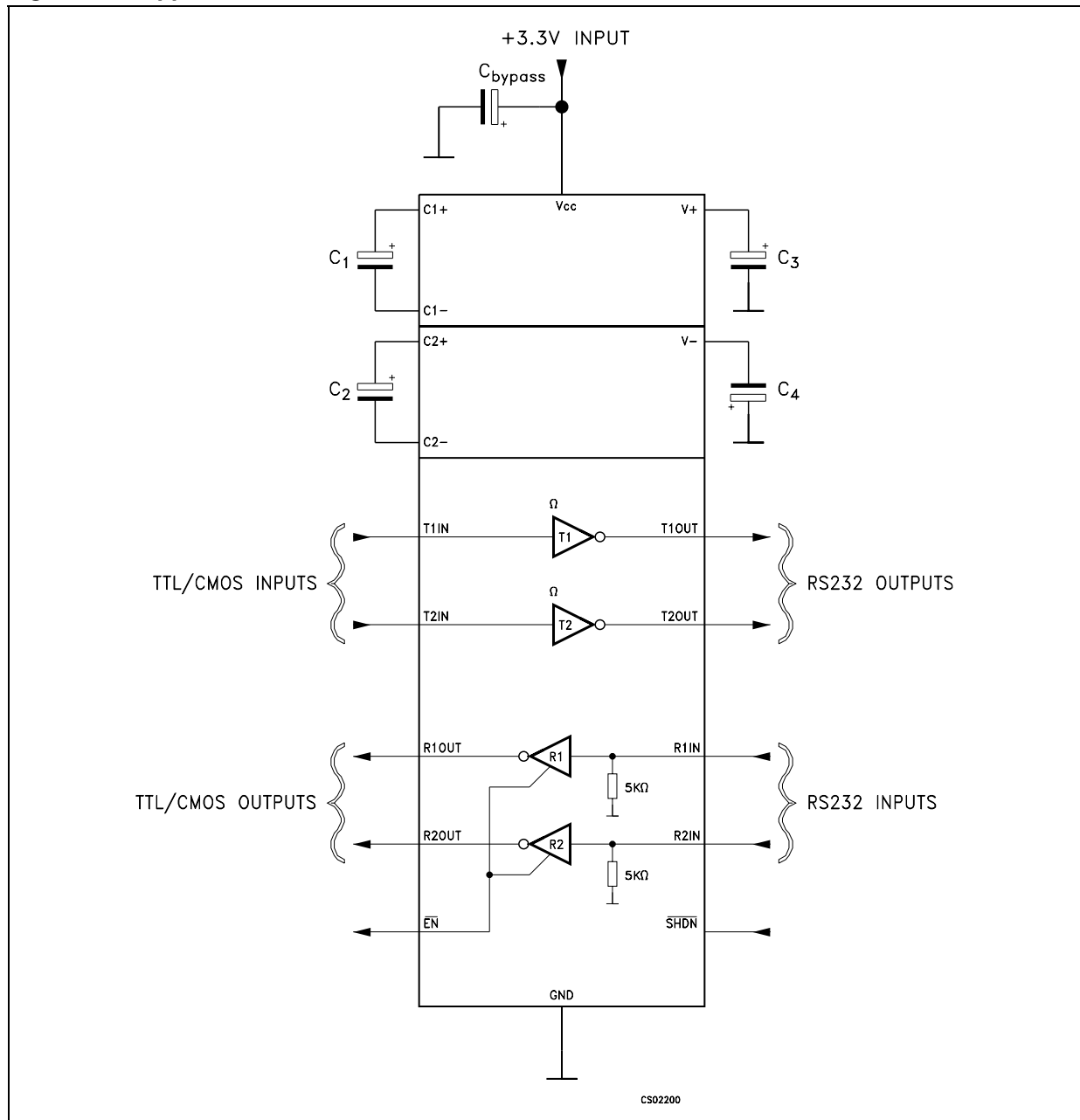

Table 11. Capacitance value (μF)

V_{CC}	C1	C2	C3	C4	Cbypass
3.0 to 3.6	0.1	0.1	0.1	0.1	0.1
4.5 to 5.5	0.047	0.33	0.33	0.33	0.33
3.0 to 5.5	0.22	0.1	0.1	0.1	0.22

5 Typical performance characteristics

(unless otherwise specified $T_J = 25\text{ }^\circ\text{C}$)

Figure 3. Output current vs output high voltage

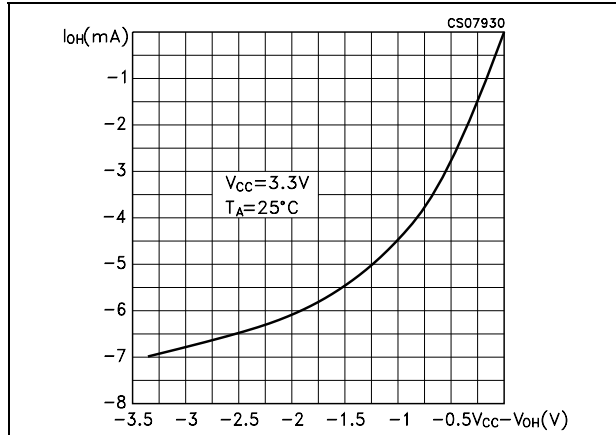

Figure 4. Output current vs output high voltage

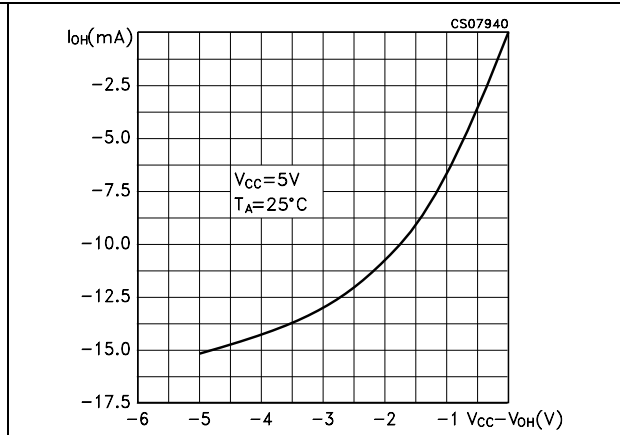

Figure 5. Output current vs output low voltage

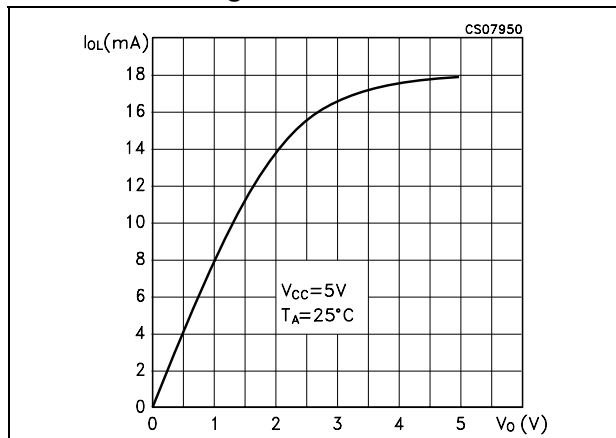

Figure 6. Output current vs output low voltage

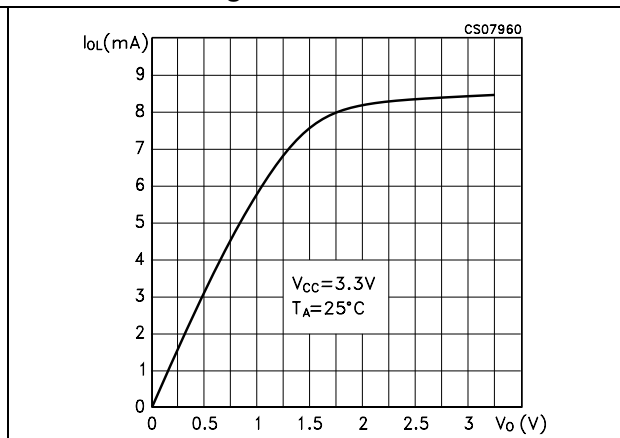

Figure 7. Voltage transfer characteristics for transmitter inputs

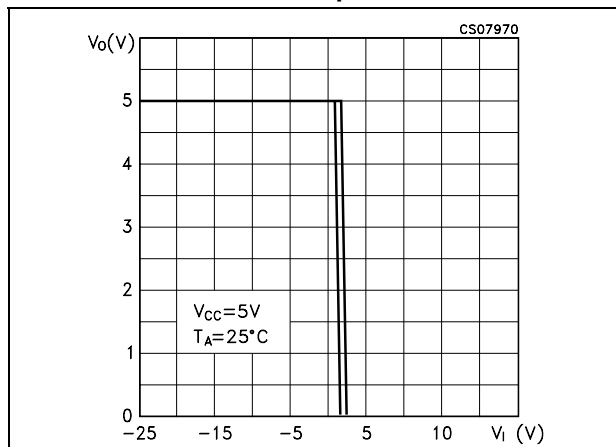
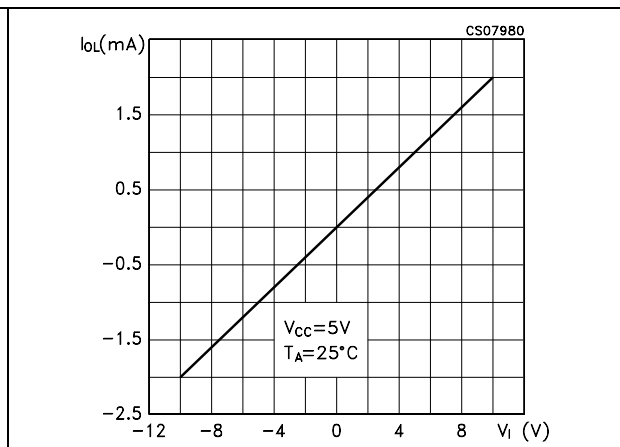

Figure 8. Receiver input resistance



6 Package mechanical data

In order to meet environmental requirements, ST offers these devices in ECOPACK® packages. These packages have a lead-free second level interconnect. The category of second level interconnect is marked on the package and on the inner box label, in compliance with JEDEC Standard JESD97. The maximum ratings related to soldering conditions are also marked on the inner box label. ECOPACK is an ST trademark. ECOPACK specifications are available at: www.st.com

SSOP20 mechanical data

Dim.	mm.			inch.		
	Min.	Typ.	Max.	Min.	Typ.	Max.
A			2			0.079
A1	0.05			0.002		
A2	1.65	1.75	1.85	0.065	0.069	0.073
b	0.22		0.38	0.009		0.015
c	0.09		0.25	0.004		0.010
D	6.9	7.2	7.5	0.272	0.283	0.295
E	7.4	7.8	8.2	0.291	0.307	0.323
E1	5	5.3	5.6	0.197	0.209	0.220
e		0.65 BSC			0.0256 BSC	
K	0°	4°	8°	0°	4°	8°
L	0.55	0.75	0.95	0.022	0.030	0.037

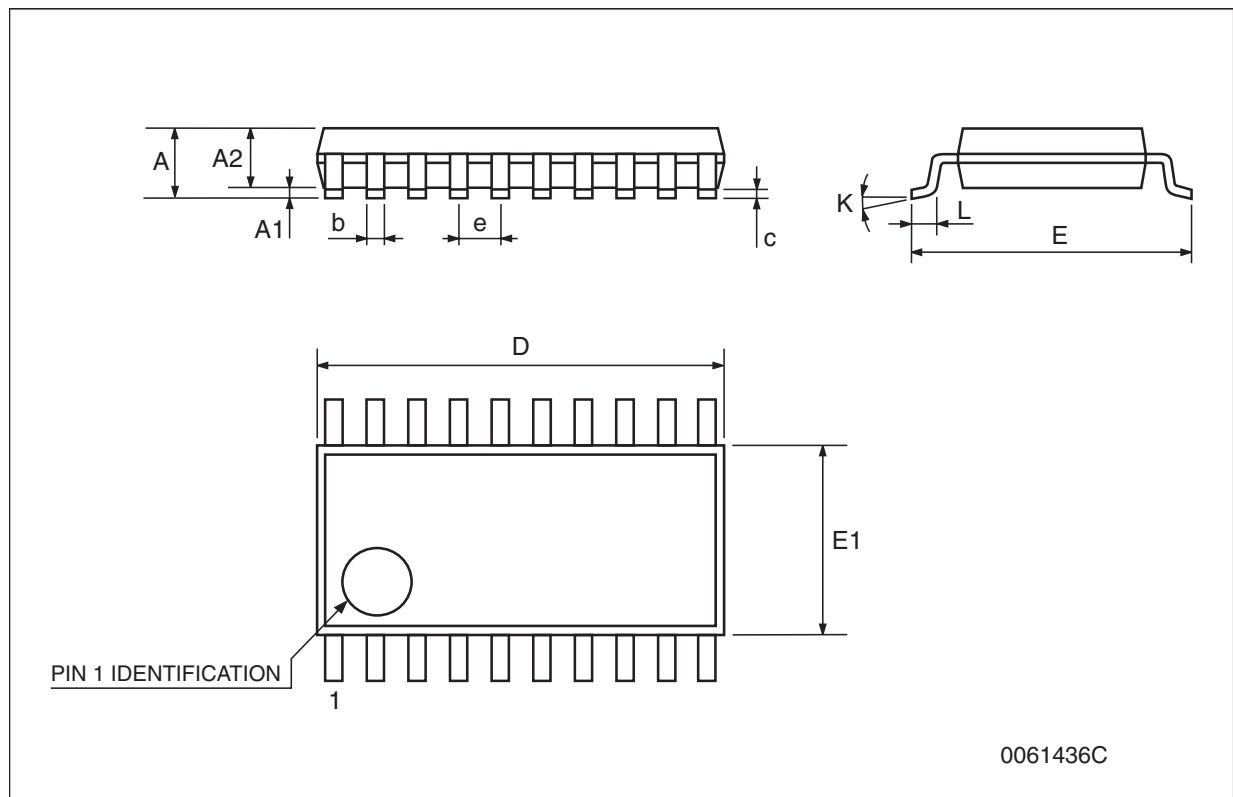

TSSOP20 mechanical data

Dim.	mm.			inch.		
	Min.	Typ.	Max.	Min.	Typ.	Max.
A			1.2			0.047
A1	0.05		0.15	0.002	0.004	0.006
A2	0.8	1	1.05	0.031	0.039	0.041
b	0.19		0.30	0.007		0.012
c	0.09		0.20	0.004		0.0079
D	6.4	6.5	6.6	0.252	0.256	0.260
E	6.2	6.4	6.6	0.244	0.252	0.260
E1	4.3	4.4	4.48	0.169	0.173	0.176
e		0.65 BSC			0.0256 BSC	
K	0°		8°	0°		8°
L	0.45	0.60	0.75	0.018	0.024	0.030

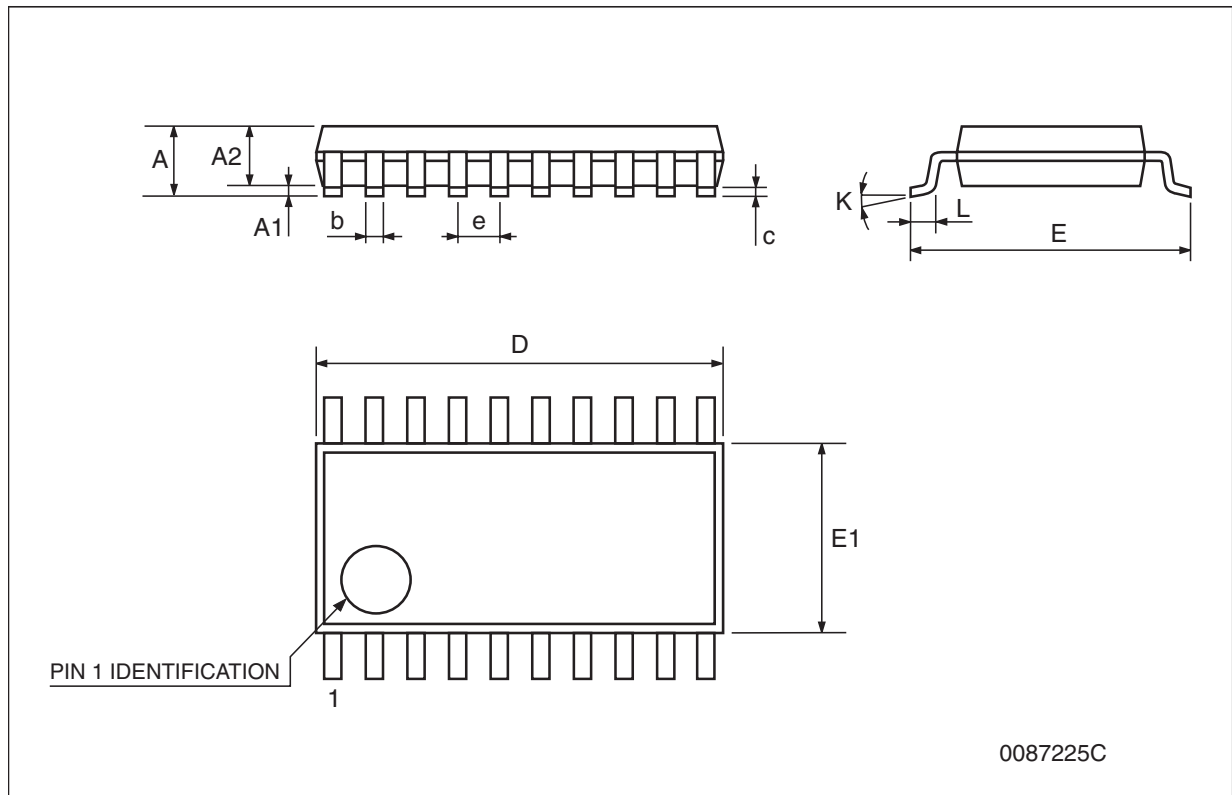

Tape & reel SSOP20 mechanical data

Dim.	mm.			inch.		
	Min.	Typ.	Max.	Min.	Typ.	Max.
A			330			12.992
C	12.8		13.2	0.504		0.519
D	20.2			0.795		
N	60			2.362		
T			22.4			0.882
Ao	8.4		8.6	0.331		0.339
Bo	7.7		7.9	0.303		0.311
Ko	2.9		3.1	0.114		0.122
Po	3.9		4.1	0.153		0.161
P	11.9		12.1	0.468		0.476



Tape & reel TSSOP20 mechanical data

Dim.	mm.			inch.		
	Min.	Typ.	Max.	Min.	Typ.	Max.
A			330			12.992
C	12.8		13.2	0.504		0.519
D	20.2			0.795		
N	60			2.362		
T			22.4			0.882
Ao	6.8		7	0.268		0.276
Bo	6.9		7.1	0.272		0.280
Ko	1.7		1.9	0.067		0.075
Po	3.9		4.1	0.153		0.161
P	11.9		12.1	0.468		0.476

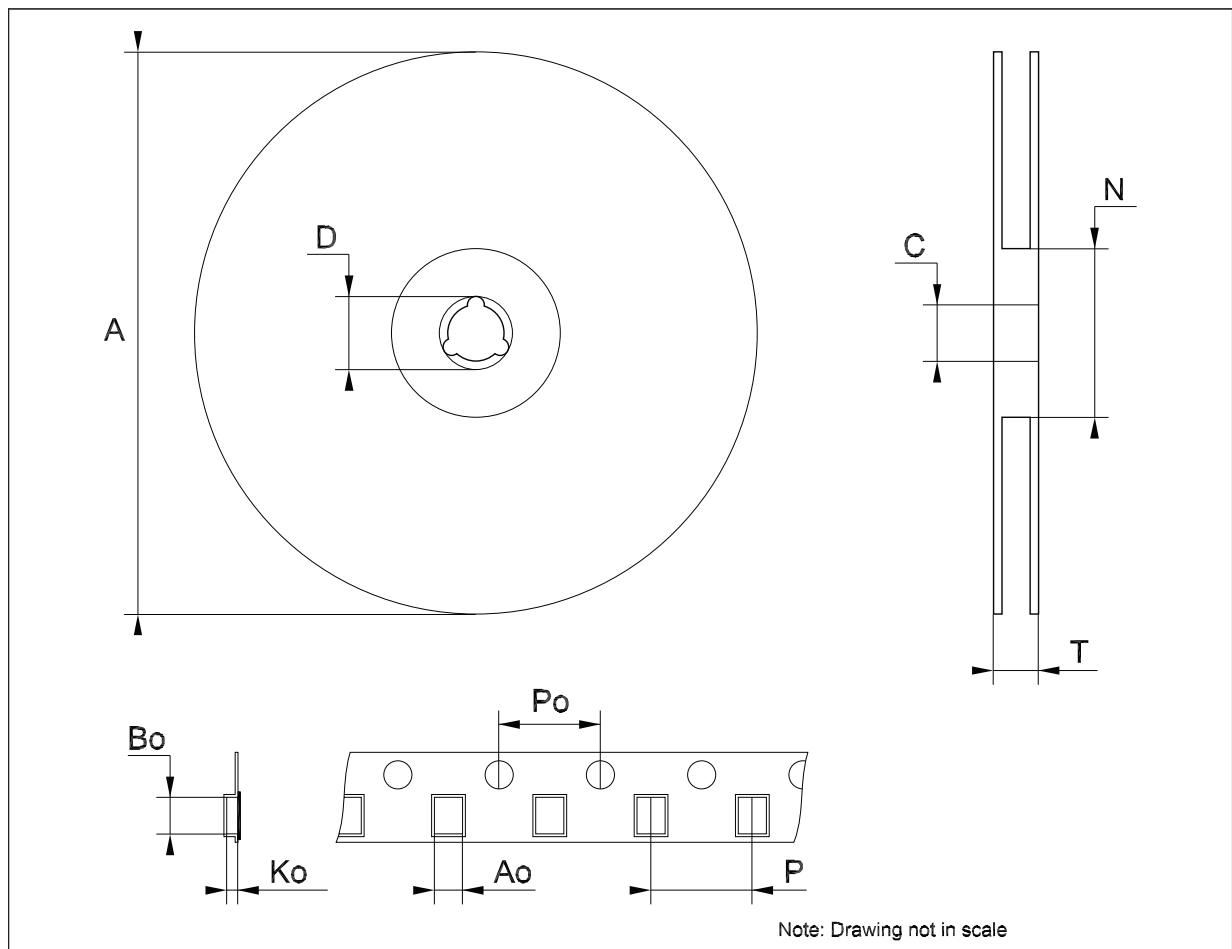

7 Revision history

Table 12. Document revision history

Date	Revision	Changes
22-Mar-2006	6	Order codes updated.
23-Aug-2007	7	Added Table 1 in cover page.
21-Jan-2008	8	Added note on Table 3 .