

Jun.1.2019 Copyright 2019 HIROSE ELECTRIC CO., LTD. All Rights Reserved.
 In case of consideration for using Automotive equipment / device which demand high reliability, kindly contact our sales window correspondents.

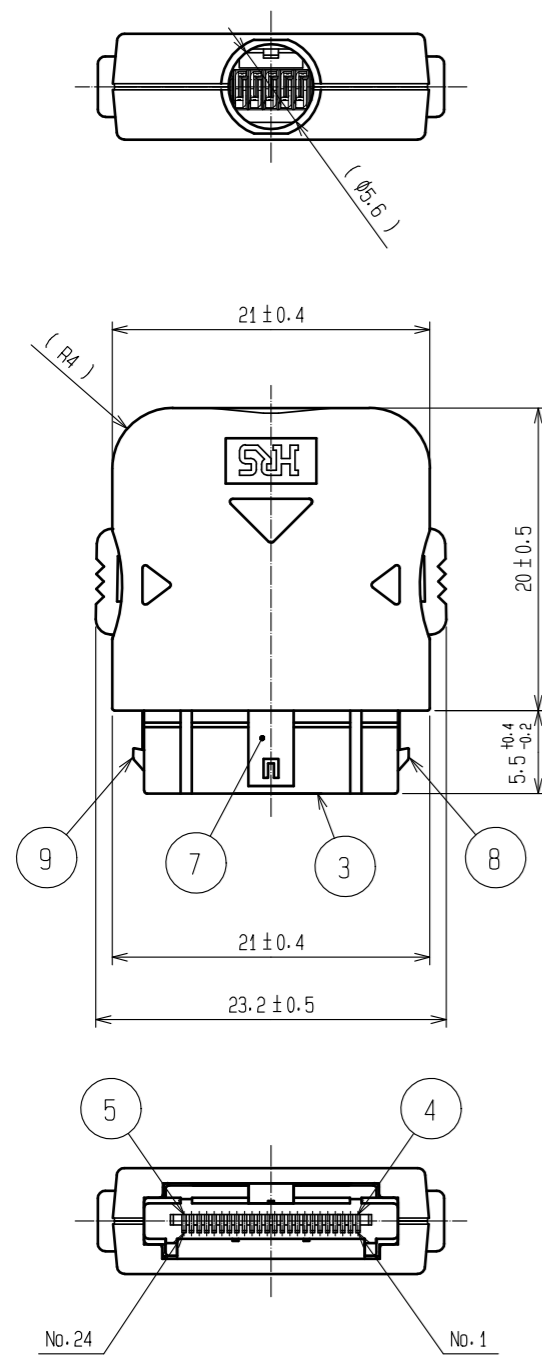

- NOTE 1 LESS THAN $\phi 4$ mm IS PRESUMED CABLE SIZE.
 2 CABLE SHALL BE OVERMOLDED WITH BUSHING TO FIX.
 USE NON-MIGRATION RESIN FOR OVERMOLDING.
 3 <PLATING>
 CONTACT AREA:GOLD PLATED 0.76 μ m MIN.
 LEAD AREA:GOLD PLATED 0.03 μ m MIN.
 UNDER PLATING:NICKEL PLATED 2 μ m MIN.
 4 THE PRODUCT IS DELIVERED IN FOLLOWING CONDITIONS:
 UNIT WITH REF 3 ASSEMBLED TO REF 4 AND 5, COVER
 WITH REF 1 ASSEMBLED TO REF 8 AND 9, AND REF 2,
 6, 7, 10 DISASSEMBLED.
 5 CLAMP METAL FOR THIS PRODUCT IS SOLD SEPARATELY.

2 BUSHING ASSEMBLY DIMENSIONS FOR REFERENCE

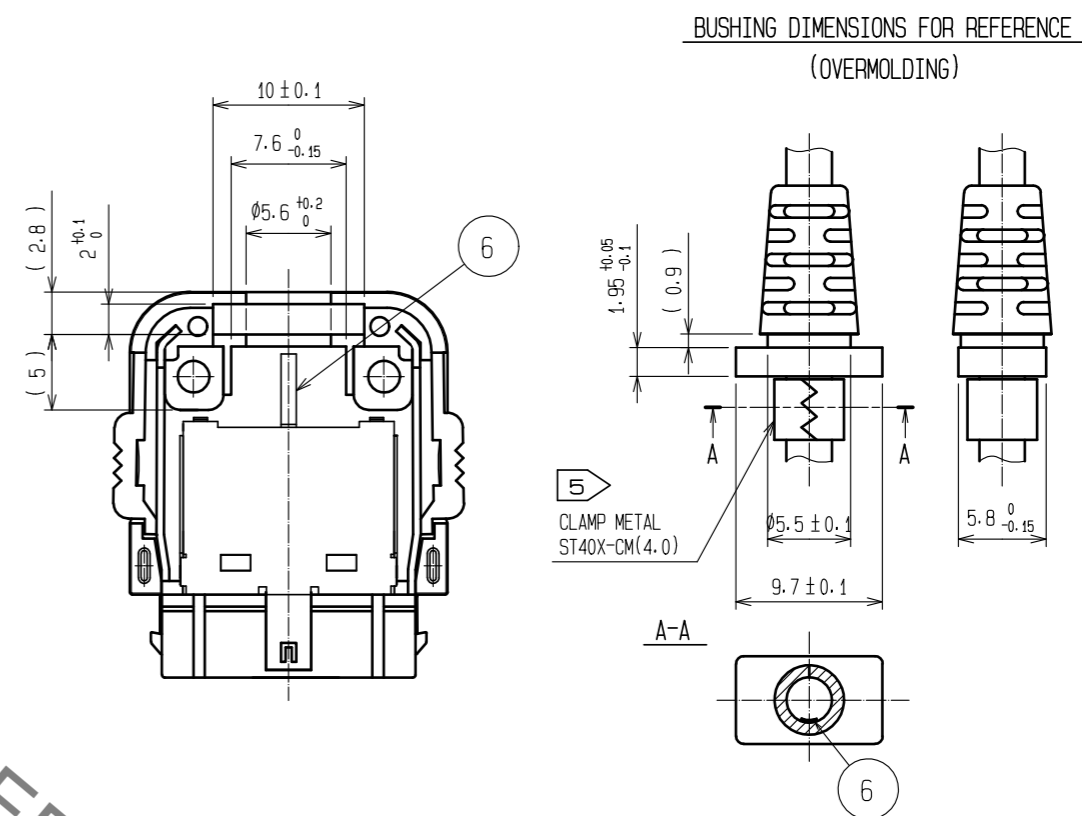

CABLE SHIELD IS CONNECTED BY CAULKING OF CLAMP METAL (COMMERCIAL ITEM)
 FITTING WITH CONNECTOR SHIELD REF 6.

NO.	MATERIAL	FINISH . REMARKS	NO.	MATERIAL	FINISH . REMARKS
5	COPPER ALLOY		10	STEEL	BLACK CHROMATE Cr3. (TAPPING SCREW)
4			9	STAINLESS STEEL	
3	POLYAMIDE	COLOR:BLACK UL94V-0	8	STAINLESS STEEL	
2	POLYCARBONATE	COLOR:BLACK UL94V-0	7	STAINLESS STEEL	
1	POLYCARBONATE	COLOR:BLACK UL94V-0	6	STAINLESS STEEL	

UNITS	SCALE	COUNT	DESCRIPTION OF REVISIONS	DESIGNED	CHECKED	DATE
mm	2 : 1					
APPROVED : NM. NISHIMATSU			15.10.27	DRAWING NO. EDC-123317-31-00		
CHECKED : KN. ICHIKAWA			15.10.27	PART NO. ST40X-24S-CV(31)		
DESIGNED : TS. ITO			15.10.27	CODE NO. CL241-0004-3-31		
DRAWN : AK. AKIYAMA			15.10.27			