

Low power RS-485/RS-422 transceiver

Features

- Low quiescent current: 300 μ A
- Designed for RS-485 interface application
- - 7 V to 12 V common mode input voltage range
- Driver maintains high impedance in 3-state or with the power OFF
- 70 mV typical input hysteresis
- 30 ns propagation delay, 5 ns skew
- Operate from a single 5 V supply
- Current limiting and thermal shutdown for driver overload protection
- Allows up to 64 transceivers on the bus

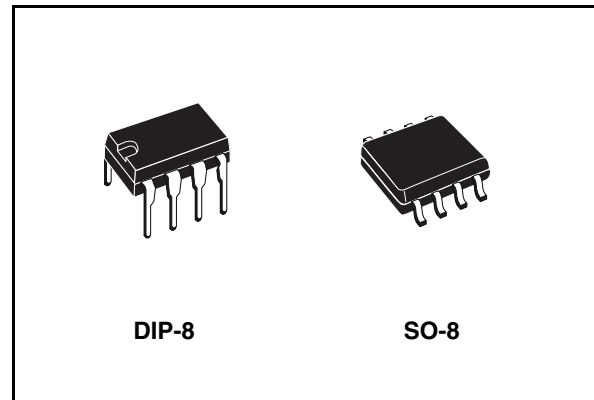

The ST485 is available in three temperature range: commercial (0 °C to 70 °C), industrial (- 40 °C to 85 °C) and automotive (- 55 °C to 125 °C).

Description

The ST485 is a low power transceiver for RS-485 and RS-422 communication. Each part contains one driver and one receiver.

This transceiver draws 300 μ A (typ.) of supply current when unloaded or fully loaded with disabled drivers.

It operates from a single 5 V supply.

Driver is short-circuit current limited and is protected against excessive power dissipation by thermal shutdown circuitry that places the driver outputs into a high-impedance state.

The ST485 is designed for bi-directional data communications on multipoint bus transmission line (half-duplex applications).

Table 1. Device summary

| Order code | Temperature range | Package | Packaging |
|------------|-------------------|----------------------|-------------------------------------|
| ST485CN | 0 to 70 °C | DIP-8 | 50 parts per tube / 40 tube per box |
| ST485BN | - 40 to 85 °C | DIP-8 | 50 parts per tube / 40 tube per box |
| ST485CDR | 0 to 70 °C | SO-8 (tape and reel) | 2500 parts per reel |
| ST485BDR | - 40 to 85 °C | SO-8 (tape and reel) | 2500 parts per reel |

Contents

| | | |
|----------|---|-----------|
| 1 | Pin configuration | 3 |
| | 1.1 Pin description | 3 |
| 2 | Truth tables | 4 |
| 3 | Maximum ratings | 5 |
| 4 | Electrical characteristics | 6 |
| | 4.1 Driver switching characteristics | 7 |
| | 4.2 Receiver switching characteristics | 8 |
| 5 | Test circuit and typical characteristics | 9 |
| 6 | Package mechanical data | 14 |
| 7 | Revision history | 18 |

2 Truth tables

Table 3. Truth table (driver)

| Inputs | | | Outputs | |
|--------|----|----|---------|---|
| RE | DE | DI | B | A |
| X | H | H | L | H |
| X | H | L | H | L |
| X | L | X | Z | Z |

Note: X = Don't care; Z = High impedance

Table 4. Truth table (receiver)

| Inputs | | | Outputs |
|--------|----|--------------|---------|
| RE | DE | A-B | RO |
| L | L | $\geq +0.2V$ | H |
| L | L | $\leq -0.2V$ | L |
| L | L | Inputs open | H |
| H | L | X | Z |

Note: X = Don't care; Z = High impedance

3 Maximum ratings

Table 5. Absolute maximum ratings

| Symbol | Parameter | Value | Unit |
|----------|---|----------------------------|------|
| V_{CC} | Supply voltage | 7 | V |
| V_I | Control input voltage (\overline{RE} , DE) | -0.5 to ($V_{CC} + 0.5$) | V |
| V_{DI} | Driver input voltage (DI) | -0.5 to ($V_{CC} + 0.5$) | V |
| V_{DO} | Driver output voltage (A, B) | ± 14 | V |
| V_{RI} | Receiver input voltage (A, B) | ± 14 | V |
| V_{RO} | Receiver output voltage (RO) | -0.5 to ($V_{CC} + 0.5$) | V |

Note: Absolute maximum ratings are those values beyond which damage to the device may occur. Functional operation under these condition is not implied.

4 Electrical characteristics

$V_{CC} = 5\text{ V} \pm 5\%$, $T_A = T_{MIN}$ to T_{MAX} , unless otherwise specified. Typical values are referred to $T_A = 25\text{ }^\circ\text{C}$

Table 6. DC electrical characteristics

| Symbol | Parameter | Test conditions ⁽¹⁾ | Value | | | | | Unit |
|-----------------|---|---|--------------|------------|------------|---------------|------------|--------------------------------|
| | | | -40 to 85 °C | | | -55 to 125 °C | | |
| | | | Min. | Typ. | Max. | Min. | Max. | |
| V_{OD1} | Differential driver output (no load) | | | | 5 | | 5 | V |
| V_{OD2} | Differential driver output (with load) | $R_L = 27\Omega$ (RS-485) <i>Figure 2</i> $R_L = 50\Omega$ (RS-422) <i>Figure 2</i> | 1.5 | | 5 5 | 1.4 | 5 5 | V V |
| ΔV_{OD} | Change in magnitude of driver differential output voltage for complementary output states | $R_L = 27\Omega$ or 50Ω <i>Figure 2</i> | | | 0.2 | | 0.2 | V |
| V_{OC} | Driver common-mode output voltage | $R_L = 27\Omega$ or 50Ω <i>Figure 2</i> | | | 3 | | 3 | V |
| ΔV_{OC} | Change in magnitude of driver common-mode output voltage for complementary output states | $R_L = 27\Omega$ or 50Ω <i>Figure 2</i> | | | 0.2 | | 0.2 | V |
| V_{IH} | Input high voltage | \overline{RE} , DE, DI | 2.0 | | | 2.0 | | V |
| V_{IL} | Input low voltage | \overline{RE} , DE, DI | | | 0.8 | | 0.8 | V |
| I_{IN1} | Input current | \overline{RE} , DE, DI | | | ± 2 | | ± 2 | μA |
| I_{IN2} | Input current (A, B) | $V_{CM} = 0\text{V}$ or 5.25V , $V_{DE} = 0\text{V}$ $V_{IN} = 12\text{V}$ $V_{IN} = -7\text{V}$ | | | 1 -0.8 | | 1 -0.8 | mA mA |
| V_{TH} | Receiver differential threshold voltage | $V_{CM} = -7$ to 12V | -0.2 | | 0.2 | -0.2 | 0.2 | V |
| ΔV_{TH} | Receiver input hysteresis | $V_{CM} = 0\text{V}$ | | 70 | | | | mV |
| V_{OH} | Receiver output high voltage | $I_O = -4\text{mA}$, $V_{ID} = 200\text{mV}$ | 3.5 | | | 3.4 | | V |
| V_{OL} | Receiver output low voltage | $I_O = 4\text{mA}$, $V_{ID} = -200\text{mV}$ | | | 0.4 | | 0.55 | V |
| I_{OZR} | 3-state (high impedance) output current at receiver | $V_O = 0.4$ to 2.4V | | | ± 1 | | ± 1 | μA |
| R_{IN} | Receiver input resistance | $V_{CM} = -7$ to 12V | 24 | | | 24 | | $\text{k}\Omega$ |
| I_{CC} | No load supply current ⁽²⁾ | $V_{RE} = 0\text{V}$ or V_{CC} $V_{DE} = V_{CC}$ $V_{DE} = 0\text{V}$ | | 400 300 | 900 500 | | 900 500 | μA μA |

Table 6. DC electrical characteristics (continued)

| Symbol | Parameter | Test conditions ⁽¹⁾ | Value | | | | | Unit |
|-------------------|--|---|--------------|------|------|---------------|------|------|
| | | | -40 to 85 °C | | | -55 to 125 °C | | |
| | | | Min. | Typ. | Max. | Min. | Max. | |
| I _{OSD1} | Driver short-circuit current, V _O =High | V _O = -7 to 12V ⁽³⁾ | 35 | | 250 | 35 | 250 | mA |
| I _{OSD2} | Driver short-circuit current, V _O =Low | V _O = -7 to 12V ⁽³⁾ | 35 | | 250 | 35 | 250 | mA |
| I _{OSR} | Receiver short-circuit current | V _O = 0V to V _{CC} | 7 | | 95 | 7 | 95 | mA |

1. All currents into device pins are positive; all currents out of device pins are negative; all voltages are referenced to device ground unless specified.
2. Supply current specification is valid for loaded transmitters when V_{DE} = 0V
3. Applies to peak current. See typical Operating Characteristics.

V_{CC} = 5 V ± 5 %, T_A = T_{MIN} to T_{MAX}, unless otherwise specified. Typical values are referred to T_A = 25 °C

Table 7. Driver switching characteristics

| Symbol | Parameter | Test conditions ⁽¹⁾ | Value | | | | | Unit |
|--------------------------------------|-----------------------------------|---|--------------|------|------|---------------|------|------|
| | | | -40 to 85 °C | | | -55 to 125 °C | | |
| | | | Min. | Typ. | Max. | Min. | Max. | |
| t _{PLH} t _{PHL} | Propagation delay input to output | R _{DIFF} = 54Ω, C _{L1} = C _{L2} = 100pF (See Figure 4 and Figure 6) | 10 | 30 | 60 | | 70 | ns |
| t _{SK} | Output skew to output | R _{DIFF} = 54Ω, C _{L1} = C _{L2} = 100pF (See Figure 4 and Figure 6) | | 5 | 10 | | 10 | ns |
| t _{TLH} t _{THL} | Rise or fall time | R _{DIFF} = 54Ω, C _{L1} = C _{L2} = 100pF (See Figure 4 and Figure 6) | 3 | 15 | 40 | 3 | 45 | ns |
| t _{PZH} | Output enable time | C _L = 100pF, S2 = Closed (See Figure 5 and Figure 7) | | 70 | 90 | | 90 | ns |
| t _{PZL} | Output enable time | C _L = 100pF, S1 = Closed (See Figure 5 and Figure 7) | | 70 | 90 | | 90 | ns |
| t _{PLZ} | Output disable time | C _L = 15pF, S1 = Closed (See Figure 5 and Figure 7) | | 70 | 90 | | 90 | ns |
| t _{PHZ} | Output disable time | C _L = 15pF, S2 = Closed (See Figure 5 and Figure 7) | | 70 | 90 | | 90 | ns |

1. All currents into device pins are positive; all currents out of device pins are negative; all voltages are referenced to device ground unless specified.

$V_{CC} = 5\text{ V} \pm 5\%$, $T_A = T_{MIN}$ to T_{MAX} , unless otherwise specified. Typical values are referred to $T_A = 25\text{ }^\circ\text{C}$

Table 8. Receiver switching characteristics

| Symbol | Parameter | Test conditions ⁽¹⁾ | Value | | | | | Unit |
|------------------------|-----------------------------------|--|--------------|------|------|--------------|------|------|
| | | | -40 to 85 °C | | | -55 to 125°C | | |
| | | | Min. | Typ. | Max. | Min. | Max. | |
| t_{PLH} t_{PHL} | Propagation delay input to output | $R_{DIFF}=54\Omega$, $C_{L1} = C_{L2} = 100\text{pF}$ (See Figure 4 and Figure 8) | 20 | 130 | 210 | | 230 | ns |
| t_{SKD} | Differential receiver skew | $R_{DIFF}=54\Omega$, $C_{L1} = C_{L2} = 100\text{pF}$ (See Figure 4 and Figure 8) | | 13 | | | | ns |
| t_{PZH} | Output enable time | $C_{RL} = 15\text{pF}$, S1 = Closed (See Fig. 2 and Figure 9) | | 20 | 50 | | 56 | ns |
| t_{PZL} | Output enable time | $C_{RL} = 15\text{pF}$, S2 = Closed (See Fig. 2 and Figure 9) | | 20 | 50 | | 56 | ns |
| t_{PLZ} | Output disable time | $C_{RL} = 15\text{pF}$, S1 = Closed (See Fig. 2 and Figure 9) | | 20 | 50 | | 56 | ns |
| t_{PHZ} | Output disable time | $C_{RL} = 15\text{pF}$, S2 = Closed (See Fig. 2 and Figure 9) | | 20 | 50 | | 56 | ns |
| f_{MAX} | Maximum data rate | | 2.5 | | | 2.5 | | Mbps |

1. All currents into device pins are positive; all currents out of device pins are negative; all voltages are referenced to device ground unless specified

5 Test circuit and typical characteristics

Figure 2. Driver DC test load

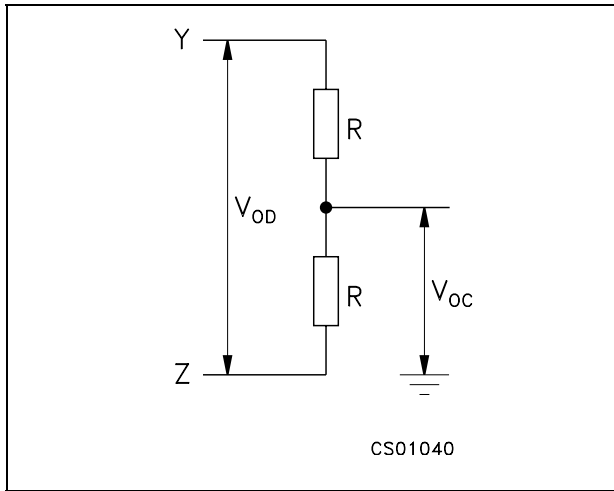

Figure 3. Receiver timing test load

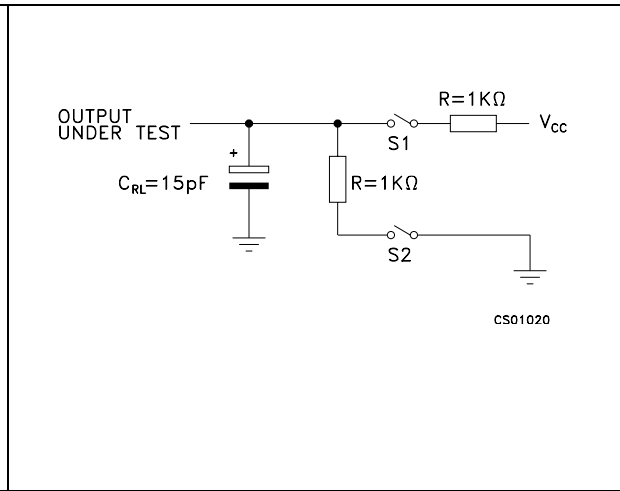

Figure 4. Drive/receiver timing test circuit

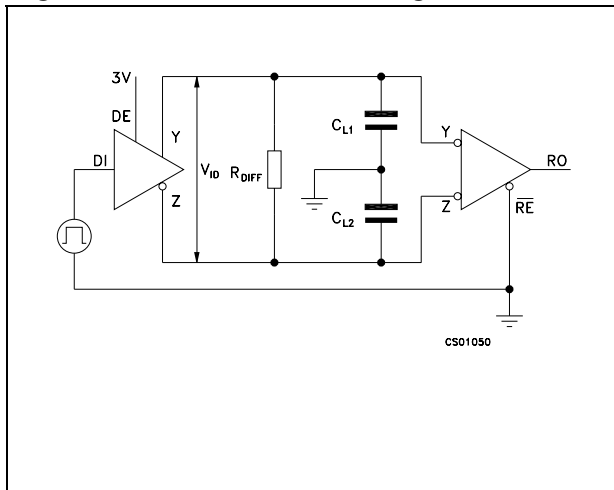

Figure 5. Driver timing test load

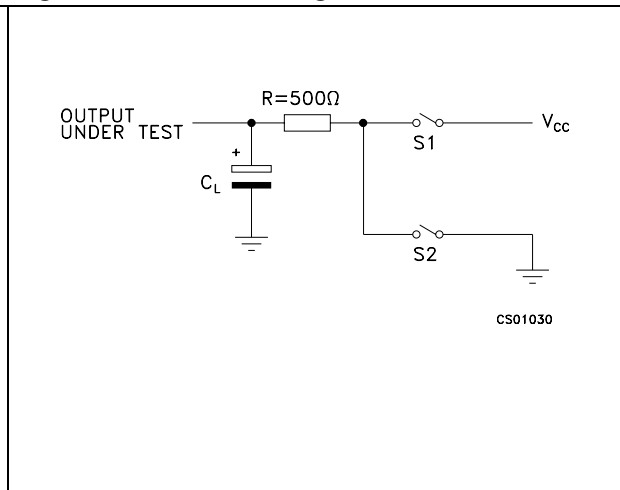

Figure 6. Driver propagation delay

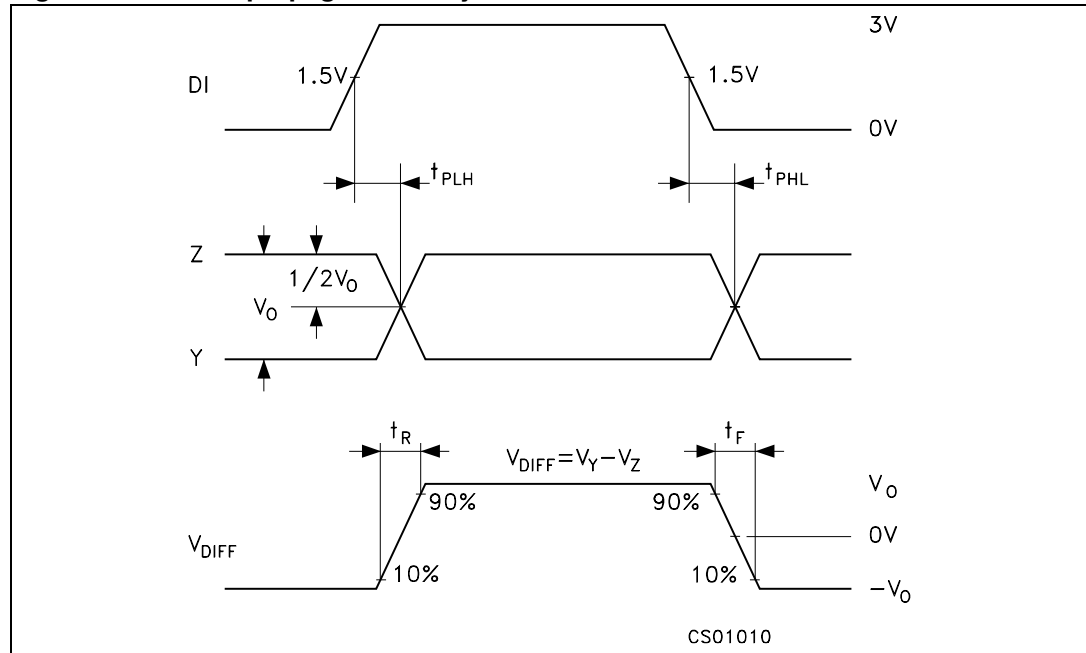

Figure 7. Driver enable and disable time

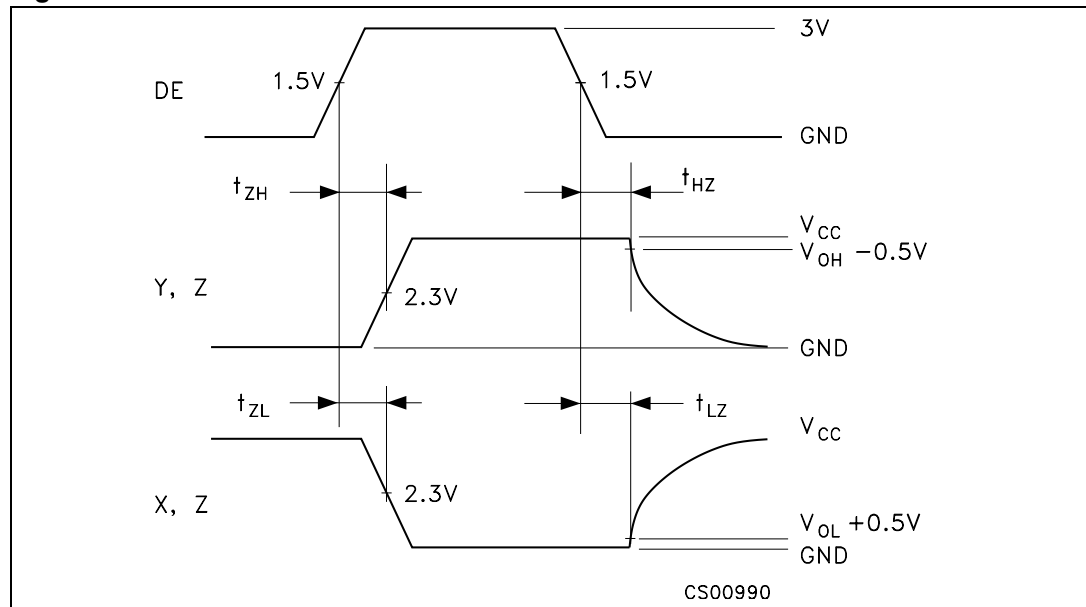

Figure 8. Receiver propagation delay

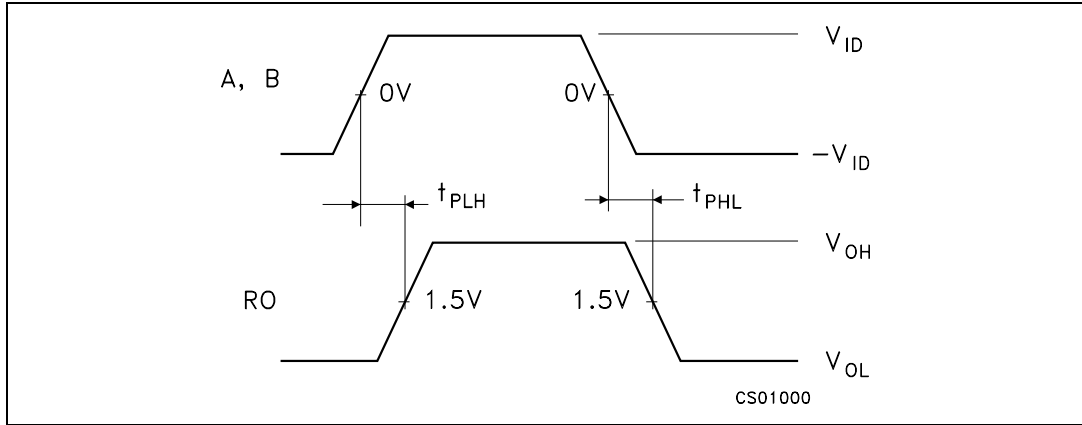

Figure 9. Receiver enable and disable time

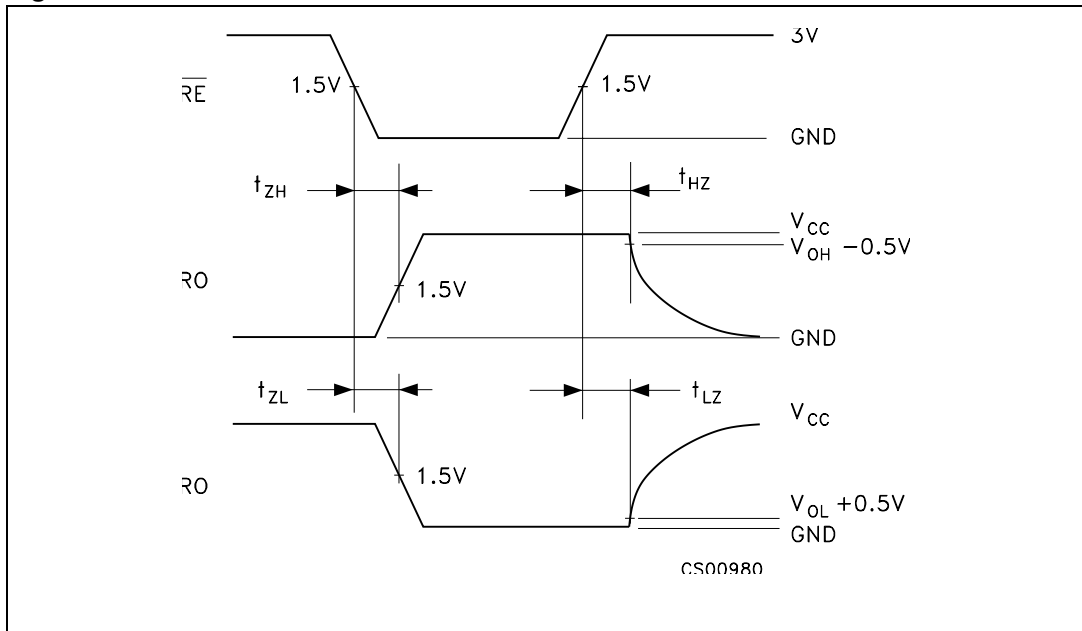

Figure 10. Receiver output current vs. output low voltage

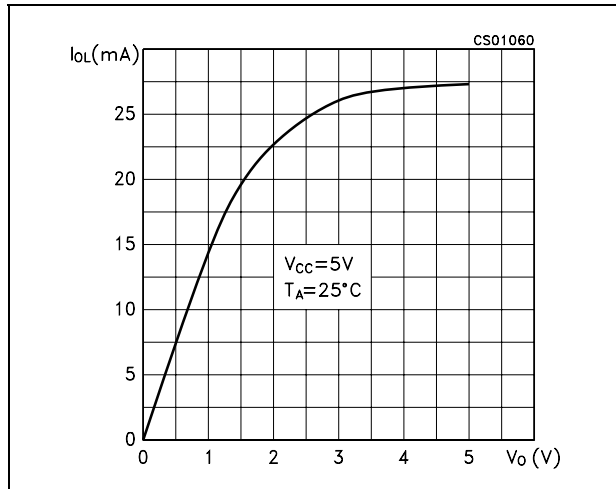

Figure 11. Receiver output current vs. output high voltage

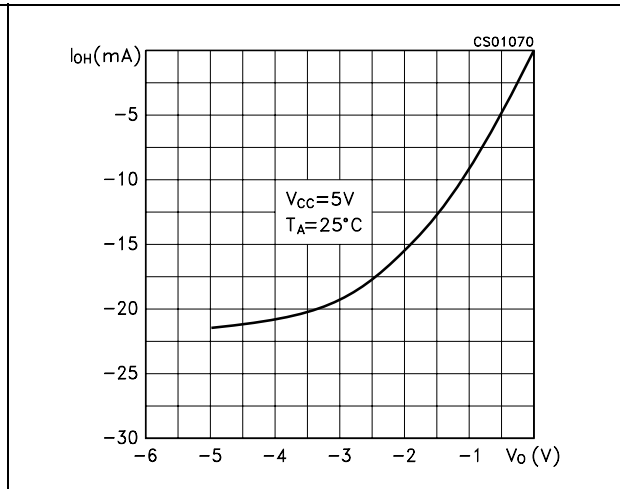

Figure 12. Driver output current vs. output low voltage

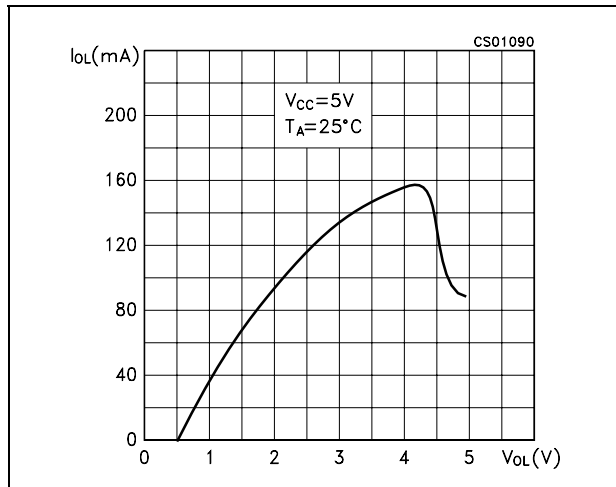

Figure 13. Driver output current vs. output high voltage

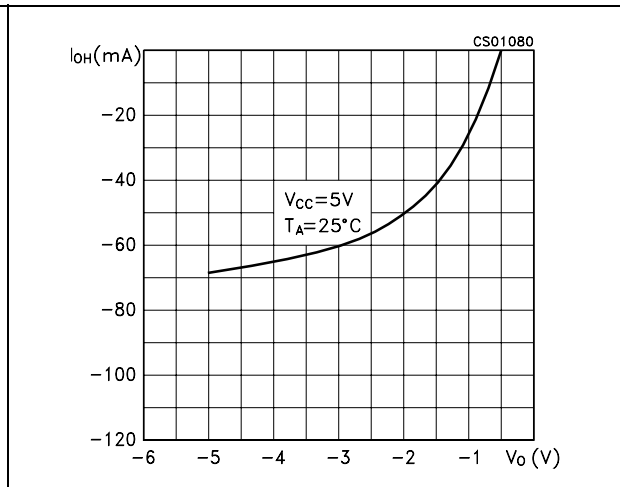

Figure 14. Supply current vs. temperature

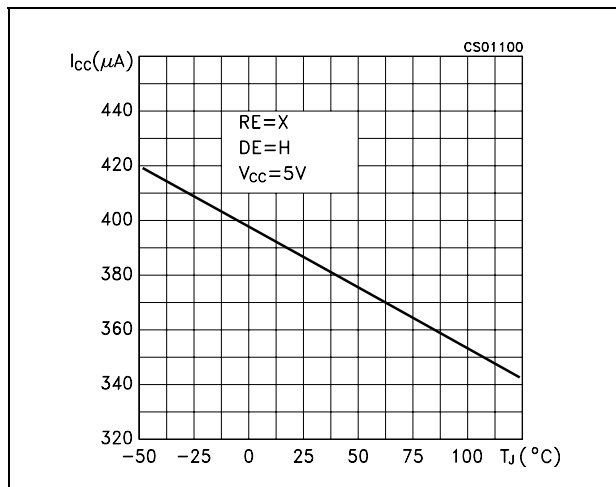

Figure 15. Receiver high level output voltage vs. temperature

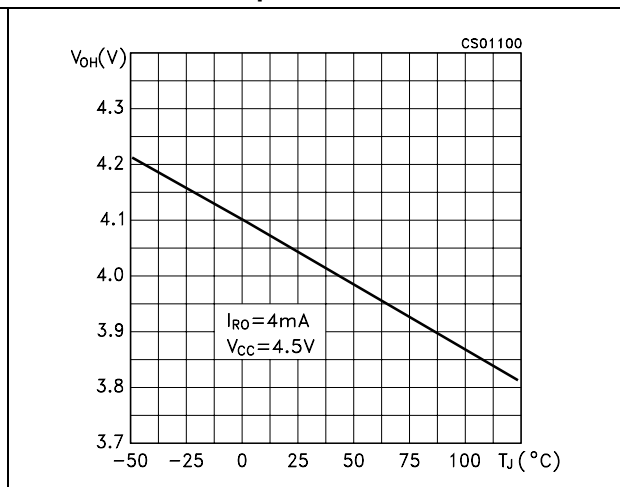

Figure 16. Receiver low level output voltage vs. temperature

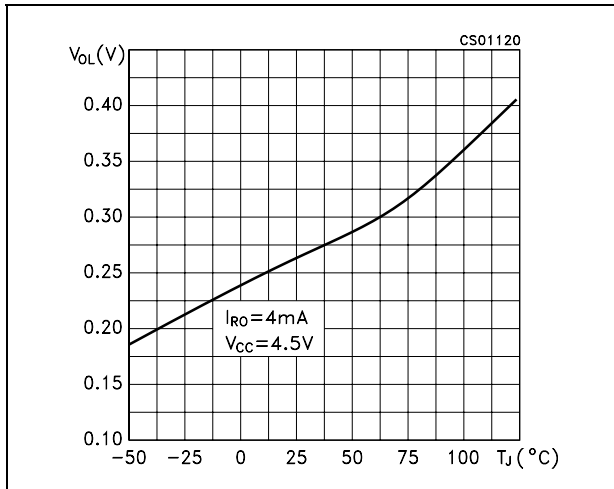
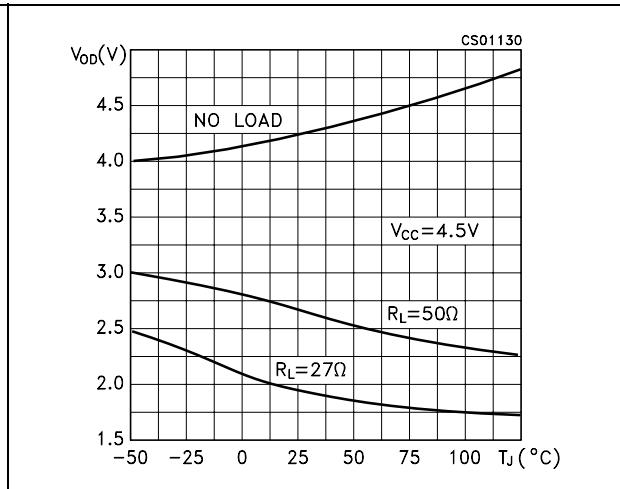

Figure 17. Differential driver output voltage vs. temperature



6 Package mechanical data

In order to meet environmental requirements, ST offers these devices in different grades of ECOPACK® packages, depending on their level of environmental compliance. ECOPACK® specifications, grade definitions and product status are available at: www.st.com. ECOPACK is an ST trademark.

Plastic DIP-8 mechanical data

| Dim. | mm. | | | inch. | | |
|------|------|------|------|-------|-------|-------|
| | Min. | Typ. | Max. | Min. | Typ. | Max. |
| A | | 3.3 | | | 0.130 | |
| a1 | 0.7 | | | 0.028 | | |
| B | 1.39 | | 1.65 | 0.055 | | 0.065 |
| B1 | 0.91 | | 1.04 | 0.036 | | 0.041 |
| b | | 0.5 | | | 0.020 | |
| b1 | 0.38 | | 0.5 | 0.015 | | 0.020 |
| D | | | 9.8 | | | 0.386 |
| E | | 8.8 | | | 0.346 | |
| e | | 2.54 | | | 0.100 | |
| e3 | | 7.62 | | | 0.300 | |
| e4 | | 7.62 | | | 0.300 | |
| F | | | 7.1 | | | 0.280 |
| l | | | 4.8 | | | 0.189 |
| L | | 3.3 | | | 0.130 | |
| Z | 0.44 | | 1.6 | 0.017 | | 0.063 |

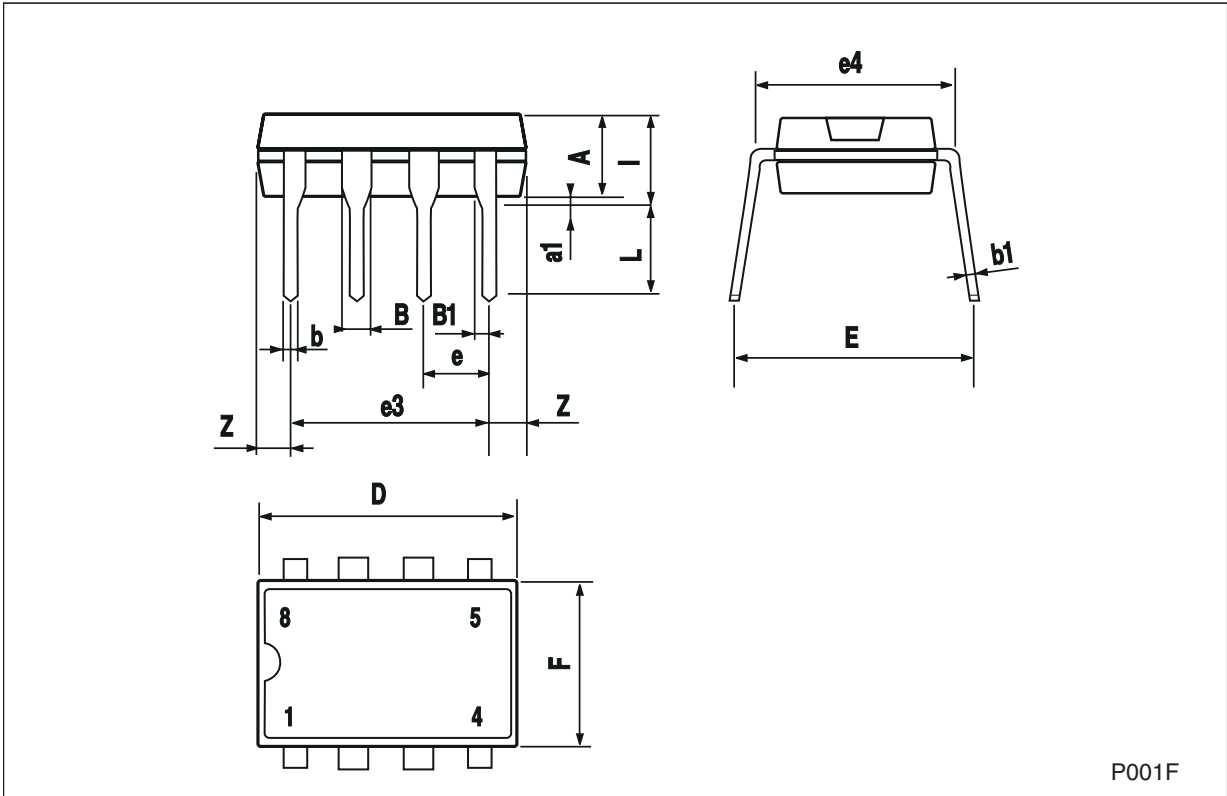

P001F

SO-8 mechanical data

| Dim. | mm. | | | inch. | | |
|------|-----------|------|------|-------|-------|-------|
| | Min. | Typ. | Max. | Min. | Typ. | Max. |
| A | 1.35 | | 1.75 | 0.053 | | 0.069 |
| A1 | 0.10 | | 0.25 | 0.04 | | 0.010 |
| A2 | 1.10 | | 1.65 | 0.043 | | 0.065 |
| B | 0.33 | | 0.51 | 0.013 | | 0.020 |
| C | 0.19 | | 0.25 | 0.007 | | 0.010 |
| D | 4.80 | | 5.00 | 0.189 | | 0.197 |
| E | 3.80 | | 4.00 | 0.150 | | 0.157 |
| e | | 1.27 | | | 0.050 | |
| H | 5.80 | | 6.20 | 0.228 | | 0.244 |
| h | 0.25 | | 0.50 | 0.010 | | 0.020 |
| L | 0.40 | | 1.27 | 0.016 | | 0.050 |
| k | 8° (max.) | | | | | |
| ddd | | | 0.1 | | | 0.04 |

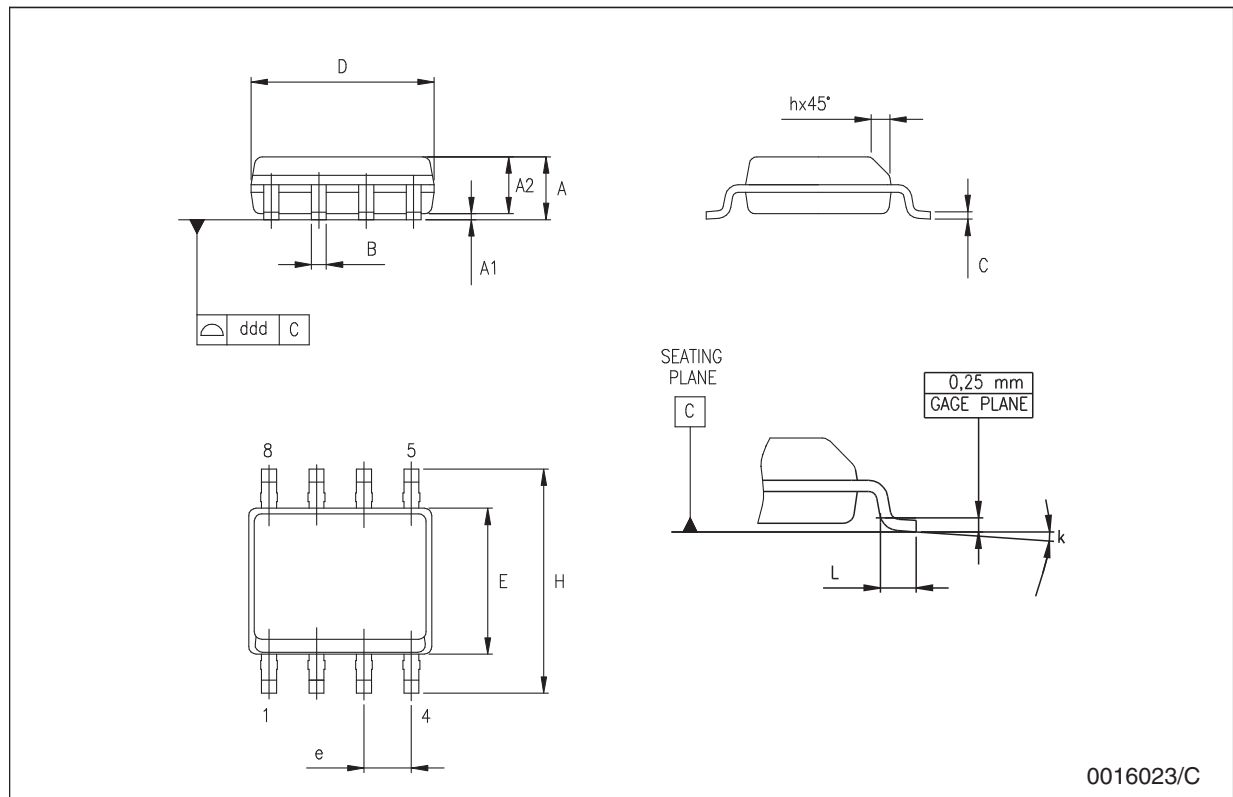

Tape & reel SO-8 mechanical data

| Dim. | mm. | | | inch. | | |
|------|------|------|------|-------|------|--------|
| | Min. | Typ. | Max. | Min. | Typ. | Max. |
| A | | | 330 | | | 12.992 |
| C | 12.8 | | 13.2 | 0.504 | | 0.519 |
| D | 20.2 | | | 0.795 | | |
| N | 60 | | | 2.362 | | |
| T | | | 22.4 | | | 0.882 |
| Ao | 8.1 | | 8.5 | 0.319 | | 0.335 |
| Bo | 5.5 | | 5.9 | 0.216 | | 0.232 |
| Ko | 2.1 | | 2.3 | 0.082 | | 0.090 |
| Po | 3.9 | | 4.1 | 0.153 | | 0.161 |
| P | 7.9 | | 8.1 | 0.311 | | 0.319 |



7 Revision history

Table 9. Document revision history

| Date | Revision | Changes |
|-------------|----------|---|
| 21-Mar-2006 | 12 | Order codes has been updated and new template. |
| 02-Aug-2006 | 13 | Mistake in cover page first row mA ==> μ A. |
| 08-Nov-2006 | 14 | Added: Table 1 . |
| 07-Feb-2008 | 15 | Modified: Table 1 on page 1 . |
| 16-Feb-2009 | 16 | Modified Note: on page 5 . |