

RF Power LDMOS transistor HF up to 1.5 GHz

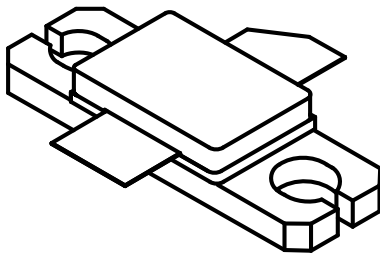

M243
Epoxy sealed

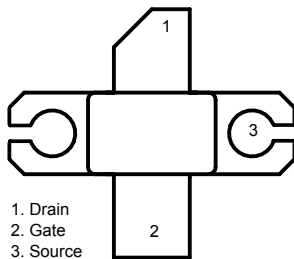

Features

- Excellent thermal stability
- Common source configuration
- Integrated ESD protection – HBM Class 2
- P_{OUT} (@28 V) = 80 W with 17 dB gain / 70% efficiency @945 MHz
- BeO free package
- In compliance with European Directive 2002/95/EC

Description

The ST9060C is a 28/32 V common source N-channel enhancement-mode lateral field-effect RF power transistor designed for broadband commercial, avionics and industrial applications at frequencies up to 1.5 GHz. The device can be used in Class A, AB and C for all typical modulation formats.

GADG310120180952IG

Product status link

[ST9060C](#)

Product summary

Order code	ST9060C
Package	M243
Branding	ST9060C

1 Maximum ratings

($T_{CASE} = 25\text{ °C}$)

Table 1. Absolute maximum ratings

Symbol	Parameter	Value	Unit
$V_{(BR)DSS}$	Drain-source voltage	90	V
V_{GS}	Gate-source voltage	-10 +13	V
I_D	Drain current	12	A
P_{DISS}	Power dissipation (@ $T_C = 70\text{ °C}$)	170	W
T_J	Maximum operating junction temperature	200	°C
T_{STG}	Storage temperature	-65 to +150	°C

Table 2. Thermal data

Symbol	Parameter	Value	Unit
R_{thJC}	Junction-case thermal resistance	0.75	°C/W

2 Electrical characteristics

($T_{CASE} = 25\text{ °C}$)

Table 3. Static

Symbol	Test conditions	Min.	Typ.	Max.	Unit
$V_{(BR)DSS}$	$V_{GS} = 0\text{ V}, I_{DS} = 10\text{ mA}$	90	94		V
I_{DSS}	$V_{GS} = 0\text{ V}, V_{DS} = 28\text{ V}$			1	μA
I_{GSS}	$V_{GS} = 12\text{ V}, V_{DS} = 0\text{ V}$			1	μA
$V_{GS(Q)}$	$V_{DS} = 28\text{ V}, I_{DS} = 300\text{ mA}$	2	2.9	5	V
$V_{DS(ON)}$	$V_{GS} = 10\text{ V}, I_{DS} = 3\text{ A}$		0.74	1.0	V
G_{FS}	$V_{DS} = 10\text{ V}, I_{DS} = 3\text{ A}$	3			S
C_{ISS}	$V_{GS} = 0\text{ V}, V_{DS} = 28\text{ V}, f = 1\text{ MHz}$		73		pF
C_{OSS}	$V_{GS} = 0\text{ V}, V_{DS} = 28\text{ V}, f = 1\text{ MHz}$		24		pF
C_{RSS}	$V_{GS} = 0\text{ V}, V_{DS} = 28\text{ V}, f = 1\text{ MHz}$		1.6		pF

Table 4. Dynamic (RF spec @ 945 MHz)

Symbol	Test conditions	Min.	Typ.	Max.	Unit
P_{OUT}	$V_{DD} = 28\text{ V}, I_{DQ} = 300\text{ mA}, P_{IN} = 1.5\text{ W}$		80	-	W
Gain	$V_{DD} = 28\text{ V}, I_{DQ} = 300\text{ mA}, P_{IN} = 1.5\text{ W}$		17.3	-	dB
Efficiency	$V_{DD} = 28\text{ V}, I_{DQ} = 300\text{ mA}, P_{IN} = 1.5\text{ W}$		70	-	%
Load mismatch	$V_{DD} = 28\text{ V}, I_{DQ} = 300\text{ mA}, P_{OUT} = 60\text{ W}$ All phase angles	20:1		-	VSWR

3 Impedance data

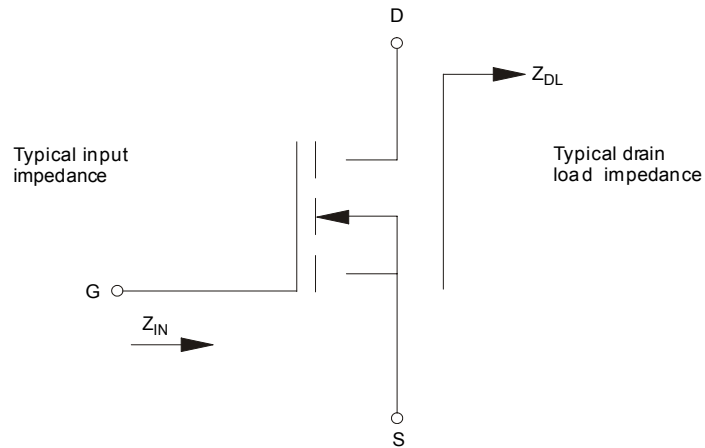
Figure 1. Impedance data

AM09249V1

Table 5. Impedance data

Frequency (MHz)	$Z_{IN}\Omega$	$Z_{DL}\Omega$
100	1.04 - j 17.7	5.2 + j 0.3
200	0.97 - j 8.9	5.1 + j 0.7
300	0.88 - j 5.8	4.9 + j 0.9
400	0.58 - j 4.3	4.6 + j 1.2
500	0.76 - j 3.1	4.4 + j 1.3
600	0.97 - j 2.3	4.1 + j 1.4
700	0.94 - j 1.8	3.8 + j 1.5
800	0.88 - j 1.5	3.5 + j 1.5
900	0.90 - j 1.2	3.2 + j 1.5
1000	0.90 - j 1.0	3.0 + j 1.4
1100	0.89 - j 0.7	2.7 + j 1.3
1200	0.86 - j 0.5	2.5 + j 1.2
1300	0.85 - j 0.3	2.3 + j 1.0
1400	0.83 - j 0.2	2.1 + j 0.9
1500	0.82 + j 0.03	2.0 + j 0.7

4 Typical performance

Figure 2. Power gain and efficiency vs output power and I_{dq} ($V_{DD} = 28\text{ V}$, $f_o = 945\text{ MHz}$)

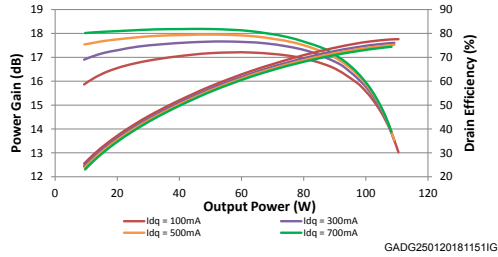

Figure 3. Power gain and efficiency vs output power and V_{DD} ($I_{dq} = 300\text{ mA}$, $f_o = 945\text{ MHz}$ tuned at $V_{DD} = 28\text{ V}$)

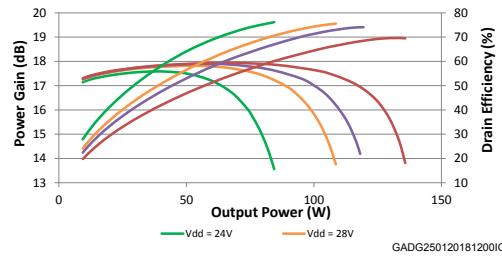

Figure 4. Output power vs V_{DD} and input power ($I_{dq} = 300\text{ mA}$, $f_o = 945\text{ MHz}$ tuned at $V_{DD} = 28\text{ V}$)

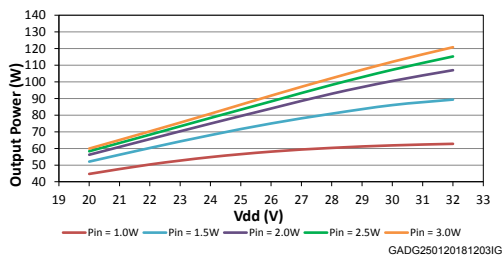
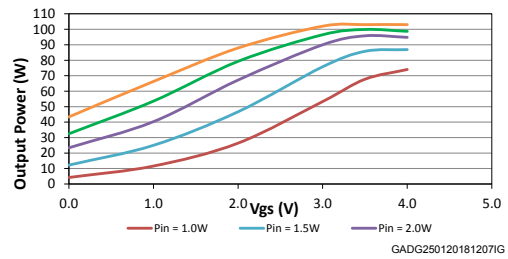
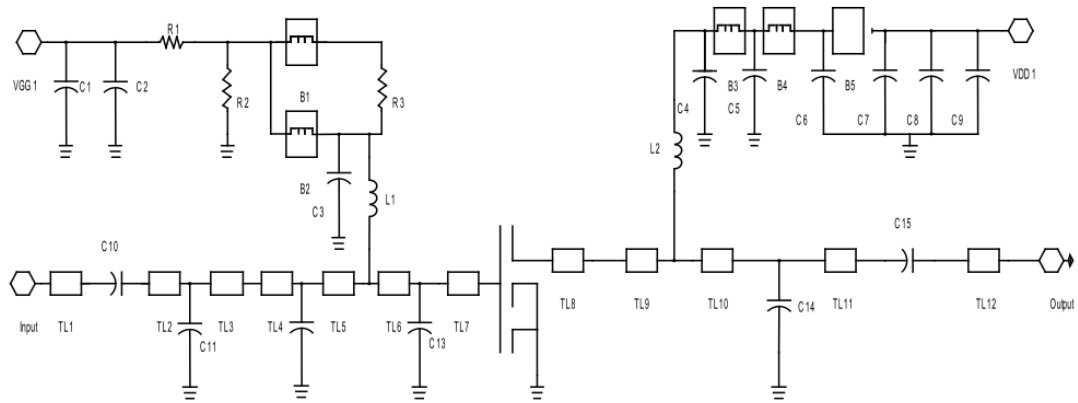

Figure 5. Output power vs V_{GS} and input power ($V_{DD} = 28\text{ V}$, $f_o = 945\text{ MHz}$)



5 Test circuit

Figure 6. Test circuit

Table 6. ST9060C components list

Item	Quantity	Part number	Vendor	Description
R1, R2	2	CR1206-8W-112JB	VENKEL	1.1 k Ω 1/8 W surface mount chip resistor
R3	1	CR1206-8W-100JB	VENKEL	10 Ω 1/8 W surface mount chip resistor
Coil	2		BELDEN	Inductor 5 turn air wound #20 AWG ID = 0.130 inches (3.3 mm) nylon coated
B1, B2, B3, B4, B5	5	2743021447	Fair-Rite Products	Surface mount EMI shield bead
C1, C7, C8	3	T491D106K035AT	KEMET	10 μ F 35 V tantalum capacitors
C2	1			100 μ F 63 V electrolytic capacitor
C3, C4, C10, C15	4	ATC100B470XXXX	ATC	47 pF chip capacitor
C5, C6	2	ATC200B393MW	ATC	39000 pF chip capacitor
C9	1			330 μ F 50 V electrolytic capacitor
C11, C13, C14	3	27291PC	Johanson Technology	0.8 to 8 pF giga-trim variable capacitor
TL1				L = 1.350 inches [34.29 mm] W = 0.082 inches [02.08 mm]
TL2				L = 0.144 inches [3.65 mm] W = 0.082 inches [02.08 mm]
TL3				L = 0.311 inches [7.91 mm] W = 0.082 inches [02.08 mm]
TL4				L = 0.082 inches [2.09 mm] W = 0.323 inches [08.21 mm]
TL5				L = 0.194 inches [4.94 mm] W = 0.323 inches [08.21 mm]
TL6				L = 0.059 inches [1.49 mm] W = 0.506 inches [12.85 mm]

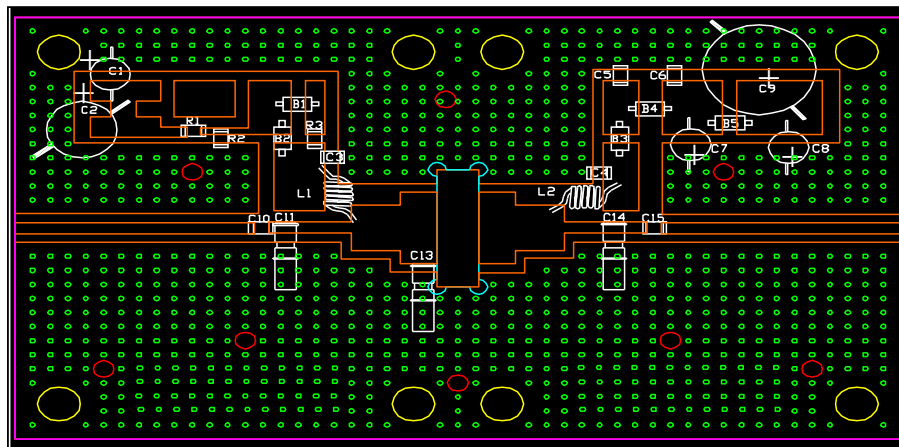
Item	Quantity	Part number	Vendor	Description
TL7				L = 0.144 inches [3.65 mm] W = 0.506 inches [12.85 mm]
TL8				L = 0.208 inches [5.28 mm] W = 0.506 inches [12.85 mm]
TL9				L = 0.275 inches [6.98 mm] W = 0.323 inches [8.21 mm]
TL10				L = 0.210 inches [5.33 mm] W = 0.082 inches [2.08 mm]
TL11				L = 0.260 inches [6.60 mm] W = 0.082 inches [2.08 mm]
TL12				L = 1.350 inches [34.29 mm] W = 0.082 inches [2.08 mm]
Board 3X5	1		ROGERS	Er = 2.55, t = 0.0026 inches, h = 0.030 inches

Figure 7. Circuit layout

6 Package information

In order to meet environmental requirements, ST offers these devices in different grades of ECOPACK® packages, depending on their level of environmental compliance. ECOPACK® specifications, grade definitions and product status are available at: www.st.com. ECOPACK® is an ST trademark.

6.1 M243 (.230 x .360 2L N/HERM W/FLG) package information

Figure 8. M243 (.230 x .360 2L N/HERM W/FLG) package outline

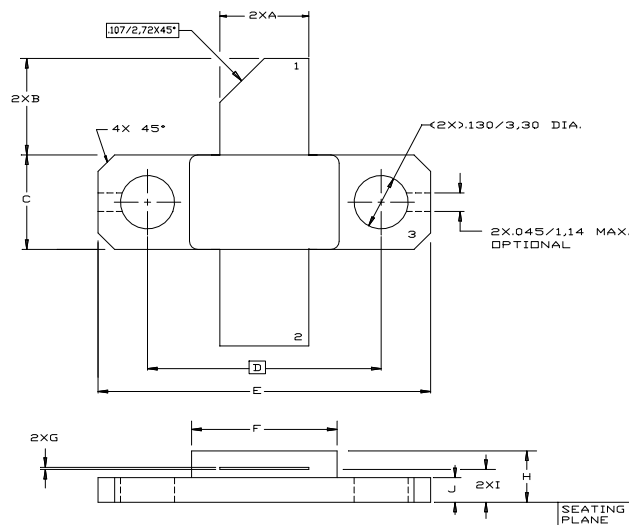

Table 7. M243 (.230 x .360 2L N/HERM W/FLG) package mechanical data

Dim.	mm		
	Min.	Typ.	Max.
A	5.21		5.72
B	5.46		6.48
C	5.59		6.1
D		14.27	
E	20.07		20.57
F	8.89		9.4
G	0.1		0.15
H	3.18		4.45
I	1.83		2.24
J	1.27		1.78

7 Marking, packing and shipping specifications

Table 8. Packing and shipping specifications

Order code	Packing	Pieces per tray	Dry pack humidity	Lot code
ST9060C	Plastic tray	25	< 10%	Two codes max.

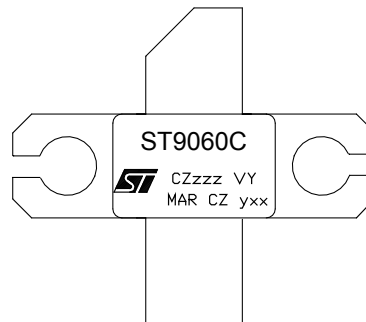
Figure 9. Marking layout

GADG250120181223IG

Table 9. Marking specifications

Symbol	Description
CZ	Assembly plant
zzz	Last 3 digits of diffusion lot
VY	Diffusion plant
MAR	Country of origin
CZ	Test and finishing plant
y	Assembly year
xx	Assembly week

Revision history

Table 10. Document revision history

Date	Revision	Changes
02-Feb-2018	1	Initial release
30-Mar-2018	2	Removed maturity status indication from cover page. The document status is production data. Updated Section 7 Marking, packing and shipping specifications . Minor text changes.

Contents

1	Maximum ratings	2
2	Electrical characteristics	3
3	Impedance data	4
4	Typical performance	5
5	Test circuit	6
6	Package information	8
6.1	M243 (.230 x .360 2L N/HERM W/FLG) package information	8
7	Marking, packing and shipping specifications	9
	Revision history	10